

ARMY AVIATION

OFFICIAL PUBLICATION OF THE ARMY AVIATION ASSOCIATION OF AMERICA, INC. • AUG-SEPT 1998 • \$3.00

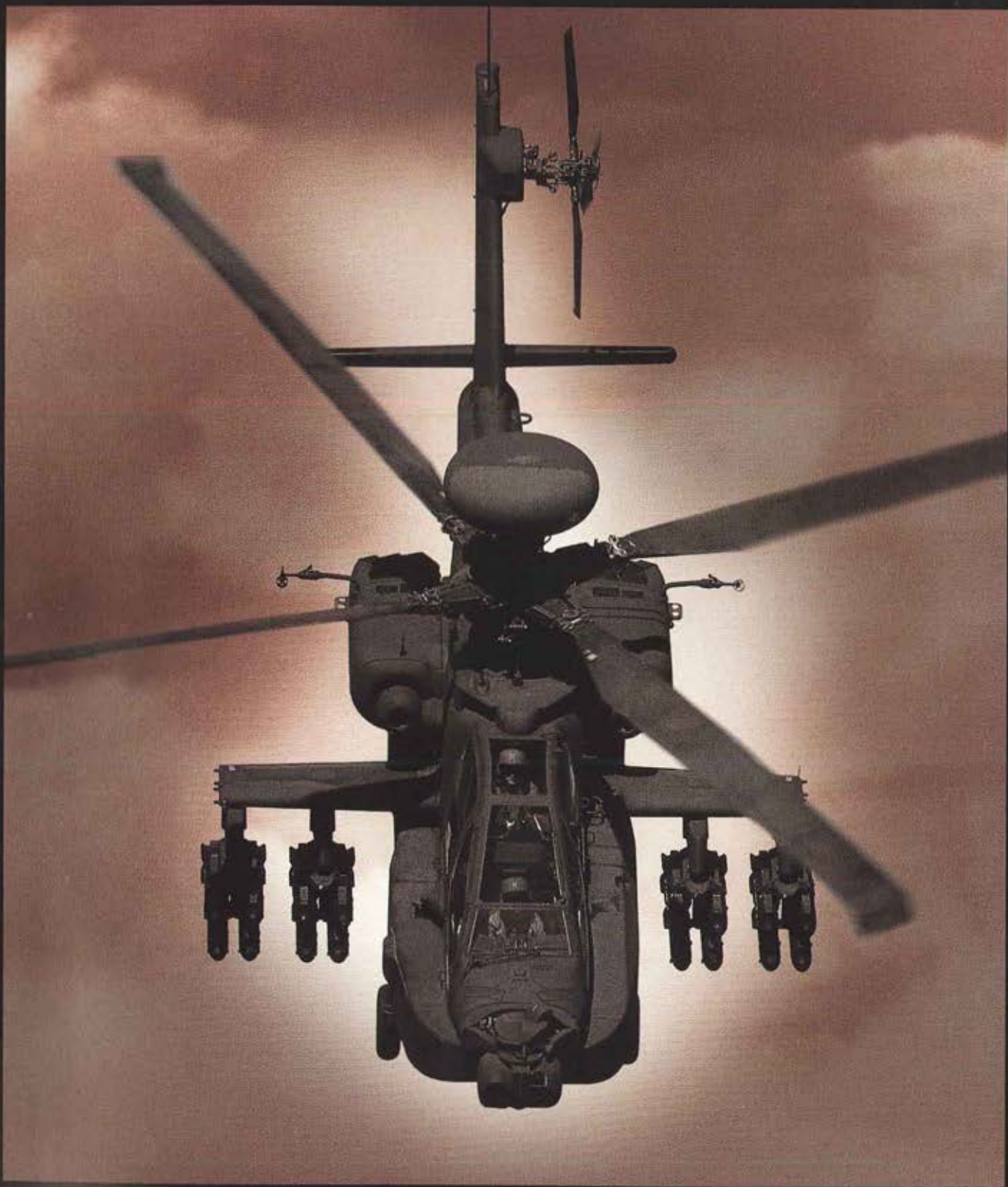

 **BOEING**

Protection Demands

A smarter, stronger, tougher warrior.

The Bell OH-58D

©1998 Bell Helicopter Textron. All rights reserved.

Today's world demands
Bell Helicopter **TEXTRON**

A Subsidiary of Textron Inc.

www.bellhelicopter.textron.com

Support The AAAA Scholarship Foundation!

Introducing the Army Aviation MasterCard® credit cards. The only credit cards to earn the Army Aviation endorsement. MBNA America® Bank, the cards' issuer, will make a contribution to the scholarship foundation—each time a card is issued or renewed, or used to make a purchase.

- No annual fee
- **Introductory 5.9% Annual Percentage Rate (APR)** on cash advance checks and balance transfers†
- Worldwide acceptance at millions of locations
- 24-hour, toll-free Customer Satisfaction, 365 days a year
- 30-minute decision on credit line increase requests

Call Now to Apply!

1-800-523-7666

TTY users, call: 1-800-833-6262.

Please use priority code HEDS when you call.



†No Annual Fee. The Annual Percentage Rate (APR) for purchases and ATM and Bank cash advances is 17.4%, which may vary. The current promotional APR offer for cash advance checks and balance transfers is 5.9% through your first five statement closing dates, commencing the month after your account is opened. When your minimum monthly payment is not received by the close of the first complete billing cycle following its Payment Due Date, or when the promotional offer expires, whichever occurs first, your APR for both new and outstanding cash advance balances (consisting of cash advance check and balance transfer transactions) will be calculated using the Variable-Rate Information disclosures accompanying your card. The current indexed APR for cash advance checks and balance transfers is 17.4%, which may vary. Transaction fee for Bank and ATM cash advances is 2% of each cash advance (minimum \$2). Transaction fee for credit card cash advance checks is 1% of each cash advance (minimum \$2, maximum \$10). Transaction fee for the purchase of wire transfers, money orders, bets, lottery tickets, and casino gaming chips is 2% of each such purchase (minimum \$2). MBNA may allocate your monthly payments to your promotional APR balance(s) before your nonpromotional APR balance(s). MBNA America is a federally registered service mark of MBNA America Bank, N.A. MasterCard is a federally registered service mark of MasterCard International Inc., used pursuant to license. The information about the cost of the card described in this advertisement is accurate as of 3/98. This information may have changed after that date. To find out what may have changed, call MBNA at 1-800-523-7666. TTY users, call 1-800-833-6262.

© 1998 MBNA America Bank, N.A.

F-14

ADG-INVZ-3/98

AD-03-98-0225

Join the efforts of members nationwide—
sign up for your
Army Aviation Association of America
MasterCard today!

No Annual Fee

contents

vol. 47 no. 8-9

August/September 1998

Publisher
Lynn Coakley

Editor-in-Chief
William R. Harris, Jr.

Editor
Stephen Harding

Contributing Editor
Lisa Eichhorn

Production Manager
Barbara Ross

Circulation Manager
Mary Ann Stirling

Circulation Assistants
Debbie Coley
Mary Ellen Kother
Deb Simons

Advertising
Peter M. Stern
Robert C. Lachowski



on the cover

Paid Advertisement. Twenty-four AH-64D Apache Longbow helicopters have taken up residence at Fort Hood, Texas, where the 1st Battalion, 227th Aviation Regiment, is undergoing three months of battalion-level combat helicopter training to become the U.S. Army's first combat-ready Apache Longbow unit. The Apache Longbow is the world's only fourth-generation combat helicopter in service. Photo by Bob Ferguson. Caption provided by advertiser.

FEATURES:

- 6** Army Heritage — Leadership Dimensions of Great Aviation Leaders
by Maj. Gen. Daniel J. Petrosky
- 12** Manning the Force
by Lt. Col. James W. Kelton
- 90** AAAA Scholarship Recipients Announced

THE 1998 INDUSTRY PARTNERS DIRECTORY

- 16** The 1998 Industry Partners Directory
The Army Aviation Industry Partners Directory is a section of the BLUEBOOK, Army Aviation's worldwide, year-round reference of our industry partners engaged in the overall field of U.S. Army aviation.

THE 1998 "BLUE BOOK" DIRECTORY

- 28** The 1998 "Blue Book" Directory
The Army Aviation Blue Book Directory is an original compilation of the organizations in which U.S. Army aviation personnel serve in key positions.

DEPARTMENTS:

Advertisers Index	81	Calendar.....	81
AAAA New Members.....	96	Career Track.....	86
AAAA News	94	Mailbox	88
Arrivals & Departures	84	Marketplace	81
Briefings	82	People on the Move.....	93

ARMY AVIATION is the official journal of the Army Aviation Association of America (AAAA). The views expressed in this publication are those of the individual authors, not the Department of Defense or its elements. The content does not necessarily reflect the official U.S. Army position nor the position of the AAAA or the staff of Army Aviation Publications, Inc., (AAPI). Title reg[®] in U.S. Patent office. Registration Number 1,533,053. SUBSCRIPTION DATA: ARMY AVIATION (ISSN 0004-248X) is published monthly, except April and September by AAPI, 49 Richmondville Avenue, Westport, CT 06880-2000. Tel: (203) 226-8184, FAX: (203) 222-9863, E-Mail: aaaa@quad-a.org. Army Aviation Magazine E-Mail: magazine@quad-a.org. Website: <http://www.quad-a.org>. Subscription rates for non-AAAA members: \$30, one year; \$58, two years; add \$10 per year for foreign addresses other than military APOs. Single copy price: \$3.00. ADVERTISING: Display and classified advertising rates are listed in SRDS Business Publications, Classification 90. POSTMASTER: Periodicals postage paid at Westport, CT and other offices. Send address changes to AAPI, 49 Richmondville Ave., Westport, CT 06880-2000.

VOICE AND DATA RECORDER • VADR™

SMITHS INDUSTRIES TOTAL SYSTEM SOLUTION

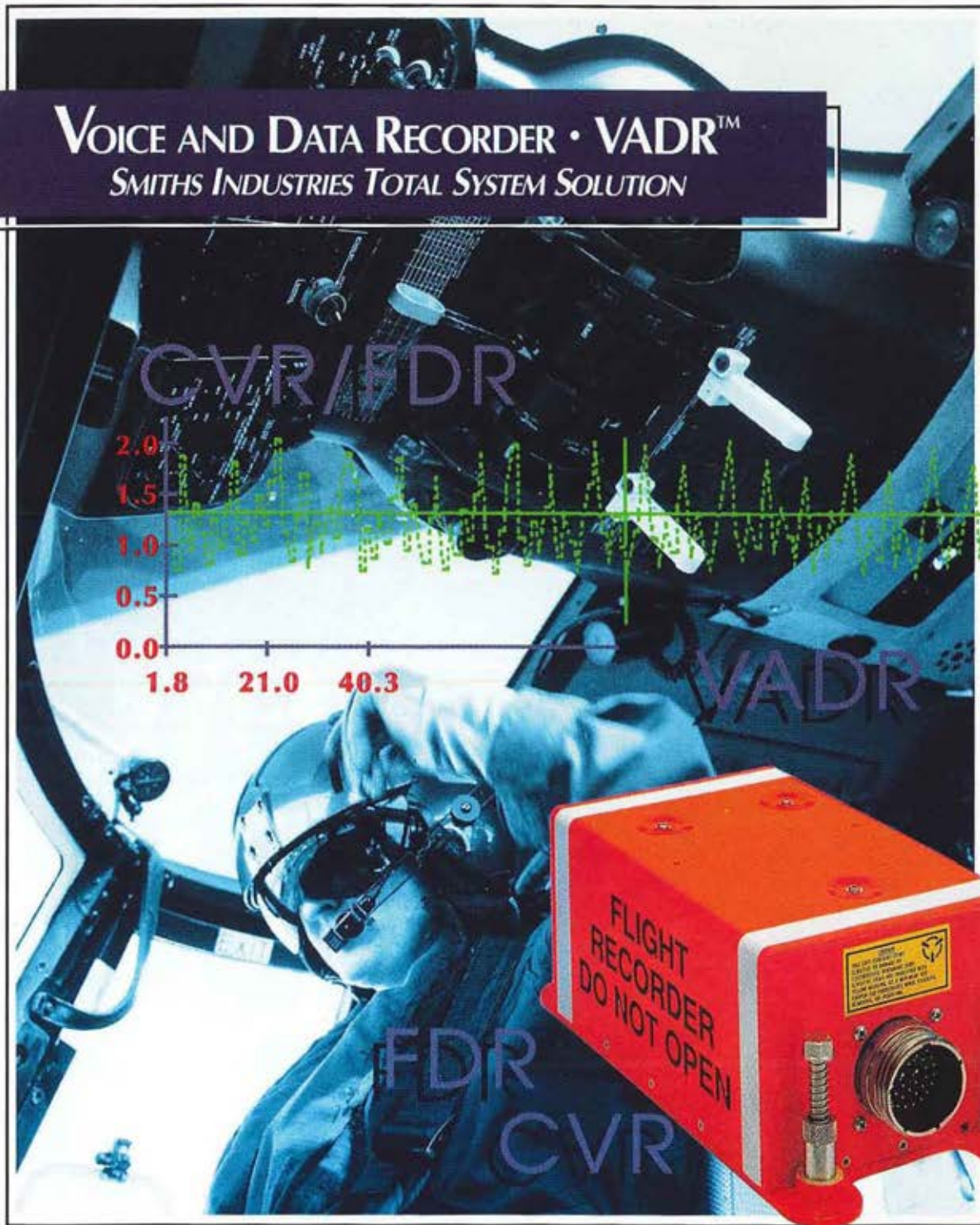

Smiths Industries systems increase the capabilities of pilots and their equipment. They improve the management of information in the air and on the ground, providing a tactical and competitive advantage. Smiths Industries is a development partner committed to innovation, investment and lifetime support – for commercial and defense priorities worldwide.

Please call for the Smiths Industries Aerospace Guide.
(USA): (616) 241 8643; (UK): (44-181) 457 8203.

Flexible configurations of voice and data recording offered by the Smiths Industries Voice and Data Recorder bring modern recorder technology to platforms previously limited by the weight and bulk of traditional recording systems.

The compact, lightweight, and affordable VADR™ is available in a variety of configurations.



SMITHS INDUSTRIES
Aerospace

"Army Heritage – Leadership Dimensions of Great Aviation Leaders"

by Maj. Gen. Daniel J. Petrosky

The past decade has been one of change. We have seen, among other things: an end to the Cold War; the dismantling of much of the world's nuclear arsenal; a reduction of the U.S. Army by some 630,000 spaces, along with the closing of over 700 bases at home and abroad; the introduction of Force XXI doctrine; preparations for a fully digitized battlefield; and a cascading assortment of new technologies to support the Army After Next.

In a world of such continuous change and uncertainty, it is all the more important for our leadership doctrine to keep pace with the changes. The emerging leadership doctrine in the Army changes its focus from the Principles of Army Leadership to the same 23 Core Dimensions of Leadership that are used in the Officer Evaluation Report (DA Form 67-9, Oct. 1997). While the words may have changed somewhat, the things that are required of a successful leader have not. These changes will make it easier for the more experienced leaders in our Army to train our successors, because they will be evaluated on those same dimensions.

There is a very good place to look for relevant lessons on leadership — the Army's 223-year history and its proud heritage and cherished traditions. As a branch, Army aviation is relatively young. Yet we have had many great leaders who have helped shape our branch and make it what it is today. Their use of the Principles of Army Leadership can be compared to the new Core Dimensions of Leadership.

Though many things have changed in the last half-century the principles the Army has stated as essential to leadership have remained fundamentally the same. Today, as we look for-

ward to the vision of Force XXI while trying every day to handle the many challenges facing our branch, it is important to look at what those principles were and where they fit into today's emerging leadership doctrine. Knowing how leaders have been successful in the past will help prepare us for success in the future. Here are a few leaders from whom we can learn valuable lessons:

Gen. James H. Doolittle

In every edition of Leadership "Know your job" has been paramount. The importance of this to aviators goes back to the earliest heroes of Army flying. A prime example was Jimmy Doolittle, who finished his career as an Air Force general. As a colonel, Doolittle gained everlasting fame on April 18, 1942, when he and his crews flew their Army Air Forces B-25 bombers off the aircraft carrier USS Hornet and bombed Tokyo barely four months after the Japanese attacked Pearl Harbor. Doolittle had previously set a host of world records for speed, altitude and endurance. He successfully did things that many of his peers could not.

Doolittle was relentless in his study of every aspect of flying. He described himself as the master of the calculated risk. For example, he took great pride in performing aerobatics that no one else could do. However, Doolittle always practiced and perfected them at safe altitudes. Moreover, Doolittle always strove to improve himself. He constantly tested his own limits, as well as those of his aircraft, to know precisely what he could do and how to do it within reasonable risks.

Doolittle also took immense pains to achieve precision. For example, to

perfect a directional gyroscope Doolittle made hundreds of blind and simulated blind landings on the same strip. Each time he lined up, then checked his position to insure the accuracy of his approach. From these many trials he was able to fine-tune both the instrument and the techniques for instrument approaches.

No aspect of flying was too remote for Doolittle to investigate, practice and refine. His studies of gasoline earned him a doctorate from the Massachusetts Institute of Technology. His discoveries led to superior fuels that gave the allies huge tactical and logistic advantages during World War II. One way or another, by the end of World War II, thousands of allied soldiers owed their lives to Jimmy Doolittle's aviation leadership.

Gen. James M. Gavin

Most Army aviators know of Gen. Hamilton Howze and the Howze Board. That board's 1962 report led to the creation of the first air-assault division, which went from experimental force to combat in Vietnam in a very short time. Many people do not know how and why — Gen. James Gavin lay behind Howze and his efforts to establish air mobility.

Gavin was orphaned at age two and grew up in a small coal-mining town. He enlisted in the Army at age 17 and rose to corporal before entering West Point in 1925. After commissioning in infantry Gavin spent three months as a flying student. He then had assignments as an infantry officer.

In 1941, as a major, Gavin asked to leave the Tactics Department at West Point to join an experimental group testing parachutes at Fort Benning. From then on, Gavin's life dealt with airborne operations. He led a night drop into Sicily in 1943. This and fol-



We Don't Blink.

Their camouflage is better. Their SAMs are faster. So your look-around has to be quick, but accurate. That's why our new Apache video system has 40% improved resolution, freeze frame capability, 120 minute record time, and uses standard videotape formats – with an option for video burst transmission.

When you only have an instant, keep your eye on TEAC.

IF IT'S WORTH A MISSION, IT'S WORTH A

TEAC
AIRBORNE PRODUCTS DIVISION

lowing operations gained him two Distinguished Service Crosses. One of his soldiers said Gavin could leap higher, shout louder, spit farther and fight harder than any other man he ever saw. He commanded the 82nd Airborne Division during Operation Market Garden — the battle made famous in the movie "A Bridge Too Far." Gavin saw and felt, first hand, the cost of traditional infantry operations. He also saw first hand the limits of parachute operations. Gavin saw that the principles of cavalry — boldness, courage and speed of movement — translated into winning battles with fewer casualties.

After World War II, as the nation turned toward reliance on a nuclear umbrella to keep the peace, Gavin remained a skeptic. In 1954 he wrote an article, published in a popular magazine, called "Cavalry — And I Don't Mean Horses." In 1955, while serving as the G-3 of the Army, Gavin chose Col. Hamilton Howze to be the chief of Army aviation. The appointment was a complete surprise to Howze, who did not know Gavin nor have an extensive involvement with aviation.

Gavin knew, though, that Howze had a great interest in mobility as the key to success on the battlefield. Gavin also knew that Howze had spent almost his whole career with combat troops and in training. Finally, Gavin sensed that Howze was capable of doing a job Gavin wanted done. As his article had set an example of publicizing the idea of air cavalry, Gavin called Howze to be an evangelist within the Pentagon.

With Gavin's backing, Howze stalked the halls of the Pentagon. He dropped into offices and talked to anyone who would listen. He took the case studies taught at Fort Leavenworth and showed how adding aviation could change the outcomes. Howze sold others, such as the vice chief of staff of the Army (VCSA). Thus, even after Gavin retired, when a new administration came in with an impatience to increase the effectiveness of Army operations, Howze was in place and able to respond.

The ultimate development of the air mobility concept in Vietnam saved thousands of lives for the kinds of soldiers that Gavin cared about. In

Vietnam, Army aviation — particularly the helicopter — greatly reduced the problem of the "Bridge Too Far." By spending the time and resources to set the stage for Howze's success, Gavin was able to change the Army to take care of soldiers better than most people had been able to imagine.

Lt. Gen. George P. Seneff

The commanders who developed the air-assault concept during Vietnam displayed an uncommon grasp of the fundamentals of leadership. George Seneff rose from colonel to lieutenant general through the development of air assault. His career and actions highlight at least six of the leadership dimensions: developing, honor integrity, assessing, executing and decision-making.

Along with Howze and Robert Shoemaker, Seneff became an Army aviator after already becoming a fairly senior officer. After attending flight school as a colonel, Seneff returned to a non-aviation assignment. In 1963 he was on his way to Germany to command a cavalry regiment when he was asked if he would rather go to Fort Benning to command one of the units in the air-assault division that was forming there. He had already been seeking a chance to become involved and immediately agreed.

The task of creating the new aviation unit was a challenge. Unlike the infantry battalions in the new division, the aviation unit he received had to be built from scratch. The development of the right tactics meant going far out on a limb in accepting responsibility. Army regulations at the time prohibited flying in formation. Regulations also prohibited flying at night, in bad weather and below restrictive altitudes. Seneff, Howze and Gen. Harry W.O. Kinnard, who commanded the division, realized they could never achieve the goals of the air assault concept within these restrictions. So, after requests for waivers were denied, they began to experiment with operations under these conditions.

For a year and a half the trio thought, discussed and tried. They developed weather-probing techniques. They did all their daytime flying on the deck and in formation. The

CRAFTSMAN®

#1 IN AVIATION

- MAS contract #GS-20F-5026H
- SCIT contract # GS-20F-5026H
- CAMP contract #GS-06F-78476
- EDI or IMPAC/other government credit cards
- GSA Advantage!™ online shopping
- NSN numbers
- FOD/foam inserts
- Custom tool sets

PHONE/FAX FOR YOUR
FREE TOOL BOOK

1-800-776-8666

Fax: 1-800-233-4557

Visit: www.commercial.sales.com

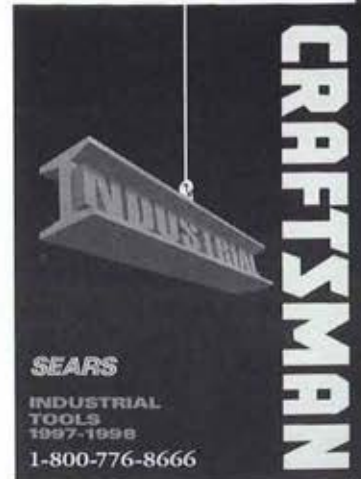

S E A R S I N D U S T R I A L S A L E S

2.7 MILLION

(A N D C L I M B I N G)

The lives of our nation's
aviators and billions of dollars in
equipment are in our hands.

And, we leave nothing to
chance. That's why DynCorp's
Fort Rucker Division is the first

contractor
ever to
reach the

milestone of 2.7 million flying
hours in nearly 10 years without
a maintenance-related accident.
It's an achievement we're proud
of and a reputation we plan to
live up to.

Our Safety Record is No Accident



DYNCORP'S RICHARD D. KENYON (MG,RET)
1997 RECIPIENT OF THE ARMY AVIATION
MATERIEL READINESS AWARD



DYNCORP IS THE ONLY 12-TIME WINNER
OF AAAA MATERIEL READINESS AWARDS

DynCorp

2000 Edmund Halley Drive
Reston, VA 20191-3436
703.264.0330

emphasis on formation and teamwork was so high that someone made a sign saying "If two of you are going to the can, fly in formation." Eventually, with night formation flying, pilots got so used to being one rotor disk apart that they preferred it. That way, they knew exactly where everyone was and could gauge each other's locations by the glow of the adjacent cockpits. To ensure safety, pilots drilled on autorotation and other emergency procedures until their reactions were absolutely automatic.

The payoff for all this work came in 1964, when opponents thought a hurricane off the East Coast would disrupt a 120-helicopter formation that was to start the critical Air Assault II demonstration. The mission would fail, the critics thought, and that would be the end of air assault. To their great surprise, however, the formation reached its objectives — while the Air Force and all civilian traffic up the eastern seaboard sat grounded. The air assault concept was decisively proven and, very shortly, was employed in combat.

The need for an improved gunship quickly became apparent in Vietnam because of high losses among crews of the UH-1B. Heavy Army investment in the AH-56 Cheyenne program created intense opposition to acquiring an interim aircraft though everyone knew the Cheyenne would not be available for several years.

Bell Helicopter had in the meantime independently developed the AH-1 Cobra and approached Seneff, who had become the director of Army aviation, about the new aircraft. Those responsible for materiel development vehemently opposed buying the Cobra because they felt it might jeopardize getting the Cheyenne. Seneff and those who felt they represented the operators vehemently supported buying the Cobra, because it suited the immediate need of the soldiers. The materiel developers produced a flood of studies to show that the Cobra was not worth acquiring, then proposed modification of another existing helicopter though that tack offered little gain over the UH-1B.

Finally, Chief of Staff of the Army Gen. Harold K. Johnson called Seneff in. The only other person there was

Gen. Creighton Abrams, the VCSA. Johnson and Abrams asked Seneff what he thought the Army needed and what the people in Vietnam wanted. Seneff told them. A week later, he was on a plane to Vietnam to take command of the new aviation brigade and to tell Gen. William Westmoreland that he would be getting the Cobra.

Lt. Gen. Harry W. O. Kinnard

Lt. Gen. Harry W. O. Kinnard was the commander who formed and fought the first air-assault division. Graduating from West Point in 1939, he went into the infantry, became a member of the 501st Parachute Infantry, and served as G-3 of the 101st Abn. Div. in the European Theater during World War II.

After the war Kinnard attended the Air Command and General Staff College, where he wrote a paper on the military future of the helicopter. He also became an Army aviator. During the 1962 Cuban Missile Crisis he had conceived of using helicopters to conduct urban operations to take out the Castro government with minimum civilian casualties. This, he later thought, probably influenced his subsequent move.

In February 1963, while assistant division commander of the 101st at Fort Campbell, he was called to become the commander of the 11th Air Assault Div. (Test) at Fort Benning. When that division was redesignated the 1st Cavalry Div. (Airmobile) in 1965, he became its first commander and deployed with it to Vietnam in July. Kinnard saw the test division as exactly that — a test. His job, as he saw it, was to take the TOE the Howze Board had created, take it out and try it in repetitive tests. In those tests the weaknesses would show, and the job was to find ways to correct them, then test the fix.

Information flow was critical to Kinnard's success. To get the best results, he insisted that commanders command their units. To encourage people to come up with ideas, he created an Idea Center where anyone of any rank could bring an idea and have it evaluated. People were there to help put the idea on paper, make drawings or do whatever it took to get down what the person had on his mind.

Kinnard also made a point of assigning each element of the division specific things he wanted them to work on beyond their normal duties. For example, he tasked the signal unit to come up with a very light signal battalion with modular radios that could be removed from aircraft and no vehicle larger than a jeep. He would often deal directly with the individuals whom he had given a specific task, although he normally functioned through regular staff and command channels.

The value of this intensive involvement and flow of information became apparent when the 11th AA Div. deployed to Vietnam. Because the president did not declare a state of emergency, many of the people who had been part of the entire development and testing of the unit were stripped out and replaced with new people. In his aviation unit, Kinnard had to release over 500 highly skilled people. The depth of understanding and knowledge was sufficient across the division that it was able to deploy and operate effectively almost immediately upon arrival. The sharing of information and the pride that came with having done the seemingly impossible also gave the unit extremely high morale. The 1st Cavalry (Airmobile) was the only unit in Vietnam to receive the Distinguished Unit Badge and only the fifth such unit in the Army's history.

As each of these examples clearly illustrates, aviation leaders throughout history have successfully employed the Principles of Leadership and those principles can be tied directly to the Army's emerging leadership doctrine, the Core Dimensions of Leadership. Leadership has provided the foundation on which we must continue to build our great branch.

We must use the Core Dimensions of Leadership in our everyday lives. Ours is a learning Army. We have learned a lot from the leaders who preceded us. Never stop learning.



Maj. Gen. Daniel J. Petrosky is commanding general of the U.S. Army Aviation Center at Fort Rucker, Ala., and chief of the aviation branch.

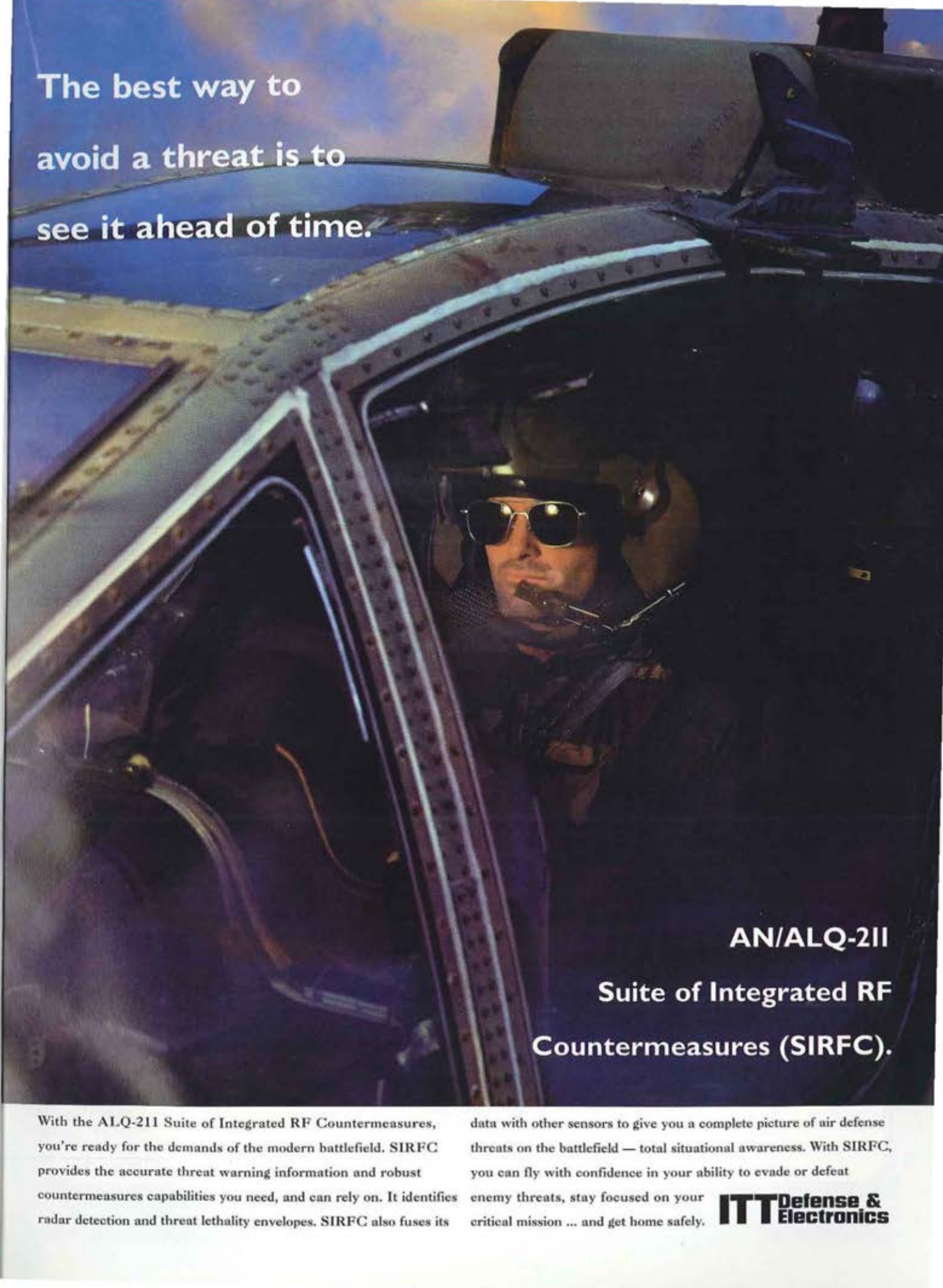

The best way to
avoid a threat is to
see it ahead of time.

AN/ALQ-211
Suite of Integrated RF
Countermeasures (SIRFC).

With the ALQ-211 Suite of Integrated RF Countermeasures, you're ready for the demands of the modern battlefield. SIRFC provides the accurate threat warning information and robust countermeasures capabilities you need, and can rely on. It identifies radar detection and threat lethality envelopes. SIRFC also fuses its

data with other sensors to give you a complete picture of air defense threats on the battlefield — total situational awareness. With SIRFC, you can fly with confidence in your ability to evade or defeat enemy threats, stay focused on your critical mission ... and get home safely.

ITT Defense &
Electronics

MANNING THE FORCE

Lt. Col. James W. Kelton

The Aviation Branch Personnel Proponency Office (AP), located at Fort Rucker, Ala., is responsible to the chief of the branch — the commanding general of the U.S. Army Aviation Center — for managing the eight personnel life-cycle functions for our total aviation force. This includes enlisted, warrant officer, commissioned officer and civilian personnel in both the active and reserve components. Think of AP as the "G-1 of the branch," responsible for "spaces" rather than "faces" and for personnel policies and procedures.

In this first of a series of monthly personnel articles, I want to provide you with the "state of the branch" from the personnel perspective. In short, Army aviation is in great shape. There are some "tweaks" needed here and there, but overall we are on course and on glide slope.

It's important to note that the Army is a very complex organization with myriad interdependent processes. Think of it as an ecosystem. And, just as in an ecosystem, if you do something upstream it is eventually going to effect the ecology downstream. Decisions made at one point in time — good decisions, made for the right reasons — may have unintended second- and third-order effects later on.

Having said that, refer to Figure 1 below.

Aviation is a young branch. Before our 1983 creation our commissioned-officer leadership ebbed and flowed into the branch when they weren't working in their basic branches or functional areas. Continuity was provided by aviation warrant officers (AWOs) and our enlisted soldiers.

At the top of the chart you can see some critical events and important decisions made by our senior Army leaders that, over the years, have resulted in the very positive trend regarding our accident rate (the 1991 spike was during Operation Desert Storm). Two very pivotal events were, first, the formation of the aviation branch and the dedicated core of commissioned officer leaders that gave us; and second, the 1988 advent of Battle Focused Training.

Now, regarding this "fragile ecosystem." The Warrant Officer Management Act (WOMA) and the Warrant Officer Leadership Development Plan (WOLDAP) aligned our AWOs with the commissioned officer personnel management system. These were good decisions, made for the right reasons. But the unintended second- and third-order effects were a loss of senior AWO experience due to "up and out" provisions for those officers twice

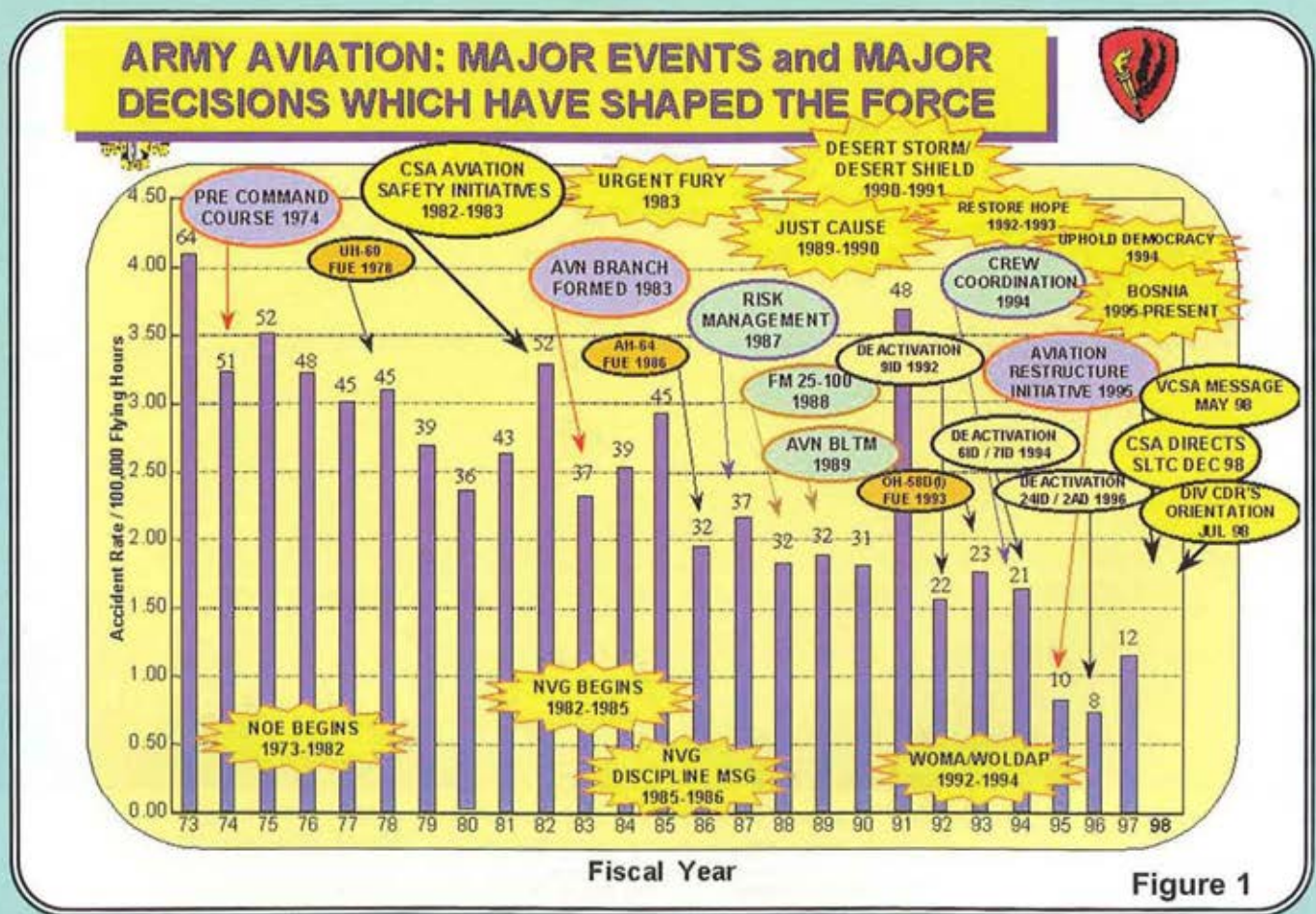

Figure 1



GUARDIAN® SYSTEMS. READY TO TAKE YOU THE DISTANCE.

GUARDIAN® Extended Range Fuel System (ERFS) for the CH-47D.

A typical ERFS consists of three 800 gallon auxiliary fuel tanks with crashworthy self-sealing bladders, single-point pressure refueling capability, self-sealing fuel hoses, restraint system, electrical cables, an NVG compatible fuel control panel with a fuel quantity indicating system and a Forward Area Refueling Equipment (FARE) kit. The ERFS provides worldwide self-deployment capability for the CH-47D. The FARE kit provides tactical forward area refueling capability to rapidly offload up to 2,400 gallons of fuel to other aircraft or weapons systems.

GUARDIAN® internal Auxiliary Fuel System for the APACHE.

The HM-025-130 internal crashworthy auxiliary fuel system provides additional mission flexibility, lowers operating costs and enhances combat capabilities for the AH-64A/D. The 130 gallon tank is interchangeable with the ammunition storage magazine and provides mission commanders with the option of carrying additional weapons on the pylons for deep penetration missions or of extending endurance for training. The auxiliary fuel tank has a crashworthy self-sealing bladder, is pressure refueled simultaneously with the aircraft, is nitrogen-inerted, and is installed or removed by two personnel using the Apache Magazine and Auxiliary Tank Transfer System (AMATTS).

For more information call (602) 967-5185, fax (602) 968-3019, e-mail robertsonaviation@worldnet.att.net, or write P.O. Box 968, Tempe, AZ 85280.

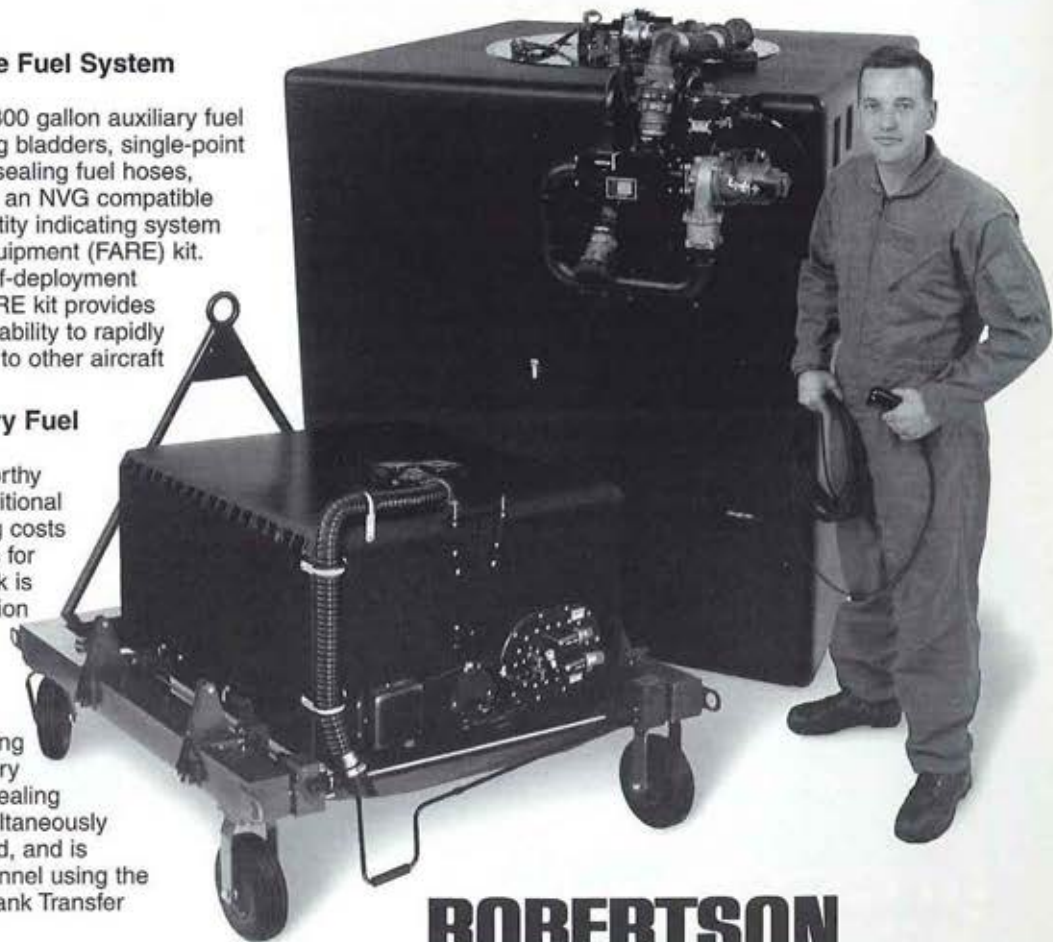

ROBERTSON
AVIATION

Range Extension Fuel Systems



MISSILE SCIENCE AND TECHNOLOGY

**INTRODUCING NEW AND
BEST-SELLING TITLES**

ADVANCES IN MISSILE GUIDANCE THEORY

Joseph Zalman Ben-Asher and Isaac Yaesch

This book is about terminal guidance of intercepting missiles. It contains a variety of newly developed guidance methods based on linear quadratic optimization problems. This application-oriented book applies widely used and thoroughly developed theories such as LQ and H-infinity to the problem of missile guidance.

1998, 200 pp, Hardcover • ISBN 1-56347-275-9 • List Price: \$79.95 • Order #: V-180(104)

TACTICAL AND STRATEGIC MISSILE GUIDANCE, THIRD EDITION

Paul Zarchan, The Charles Stark Draper Laboratory, Inc.

This best-seller covers covariance analysis and the homing loop, ballistic target properties, extended Kalman filtering and ballistic coefficient estimation, and ballistic target challenges. The third edition features five new chapters on such timely aerospace issues as the multiple target or aim-point shift problem and the challenges posed by spiraling targets and flight control design fundamentals. Companion software, in both Macintosh and IBM-compatible versions, contains source code listings in FORTRAN, C, and MATLAB™ languages.

1998, 611 pp, Hardcover • ISBN: 1-56347-254-6 • List Price: \$109.95 • Order #: V-176(104)

CONVENTIONAL WARHEAD SYSTEMS PHYSICS AND ENGINEERING DESIGN

Richard Lloyd, Raytheon Electronic Systems

In his exploration of the mathematical equations and logic behind antiballistic missiles (ATBMs), Lloyd takes an in-depth look at theater missile defense as well as warhead design and concepts for ATBMs. Hailed as the perfect companion to *Tactical Missile Warheads*, the book demonstrates the system aspects you'll need as a systems warhead engineer designing complex tactical and defense warheads under tight budgetary constraints.

1998, 636 pp, illus, Hardcover • ISBN 1-56347-255-4 • List Price: \$104.95 • Order #: V-179(104)

TACTICAL MISSILE WARHEADS

Joseph Carleone, Aerojet, editor

1993, 745 pp, Hardcover • ISBN 1-56347-067-5 • List Price: \$109.95 • Order #: V-155(104)

TACTICAL MISSILE PROPULSION

G.E. Jensen, United Technologies Corporation, and David W. Netzer, Naval Postgraduate School, editors

1996, 529 pp, Hardcover • ISBN 1-56347-118-3 • List Price: \$104.95 • Order #: V-170(104)

TEST AND EVALUATION OF THE TACTICAL MISSILE

E.J. Eichblatt Jr., Pacific Missile Test Center, editor

1989, 432 pp, Hardcover • ISBN 0-930403-56-8 • List Price: \$65.95 • Order #: V-119(104)



Call **800/682-2422** to order your copy today! Visit www.aiaa.org to view complete tables of contents.

American Institute of Aeronautics and Astronautics, 9 Jay Gould Ct, P.O. Box 753, Waldorf, MD 20604
Fax **301/843-0159** Phone **301/645-3651**

98-1231

non-selected for promotion, and the removal of senior AWO representation down at company level.

Another unanticipated impact was caused by policies which created provisional warrant officers (MOS 003A). Since warrant officer candidates now pin on their rank after the six-week Warrant Officer Candidate School, they count against our overall warrant officer budgeted end strength (BES) even though they haven't completed flight school and aren't ready for assignment.

This is but one example of some of the second- and third-order effects in the personnel arena. On July 22 we laid out several of these issues to the vice chief of staff of the Army, Gen. Crouch. The VCSA was very supportive and the Army staff is working with us now as we look toward innovative solutions. Some of the other issues and initiatives include:

- Returning senior AWO experience to unit level,
- a centralized automated visibility of flight experience system,
- increasing our capacity to train enlisted soldiers,
- Air Traffic Services restructuring,
- Apache aviator retention,
- Longbow fielding,
- modernizing our enlisted force, and
- outsourcing flight detachments.

We'll explore some of these individually and in more depth in subsequent articles.

The bottom line is: Army aviation is looking good. We're addressing some important issues that need some on-course corrections, and we've got senior branch and Army leaders who are committed to helping us keep Army aviation "Above the Best."

But we need to know your perspective on what's happening in your lanes out there in the field. I encourage you to check out the AP website that can be accessed from the Fort Rucker homepage at <http://www-rucker.army.mil>. Check out the latest on these and other issues, look at the career handbook online, review the worldwide aviation directory, or send us an e-mail and let us know what your concerns are. We look forward to hearing from you. Until next issue: "Soldiers Are Our Credentials!"



Lt. Col. James W. Kelton is chief of the Aviation Proponency Office at the U.S. Army Aviation Center, Fort Rucker, Ala.

RECONFIGURABLE TACTICAL TRAINERS



Warrior Training XXI

When the customer's requirement calls for teams of helicopter simulators to interoperate in a collective, combined arms environment against an interactive threat force, Reflectone's networked RTTs are the affordable tactical training solution.

AH-64, UH-60 and OH-58 configurations shown

 **REFLECTONE**

A British Aerospace Company

4908 Tampa West Boulevard • Tampa, Florida 33634-2481

TEL: (813) 887-1430 / 885-7481 FAX: (813) 887-1770

www.reflectone.com

ARMY AVIATION INDUSTRY PARTNERS DIRECTORY

The Army Aviation Industry Partners Directory is a section of the BLUEBOOK, Army Aviation's worldwide, year-round reference of individuals and organizations engaged in the overall field of U.S. Army Aviation. The following organizations have been listed on request and are listed by the following categories: 1) Manufacturing; 2) Maintenance/Repair/Overhaul; and 3) Consultants/Special Services. Any firm that wishes to be included in next year's directory should contact Bob Lachowski at Army Aviation Publications, Inc., 49 Richmondville Avenue, Westport, CT 06880; Telephone: (203) 226-8184, ext. 131; FAX: (203) 222-9863

MANUFACTURING

Air Methods Corporation

Denver/Centennial Airport
7301 S. Peoria
Englewood, CO 80112
Multi Mission Interiors/Airframe Access/Avionics
Mods/Engr. Svcs.
Vice President, Products Div.: Mr. Michael G. Prieto
C: 303-792-7400; FAX: 303-790-0499
info@airmethods.com

(SEE OUR AD ON PAGE 45)

Allison Engine Company

P. O. Box 420
Indianapolis, IN 46206-0420
Turbine Engines
Director of Business Development: Mr. Wayne Killian
MAIL STOP: S22C
C: 317-230-5351; FAX: 317-230-3410
Wayne.D.Killian@allison.com

Anchor Continental, Inc.

P.O. Box G
Columbia, SC 29250
Blast Tape 100-for use w/plastic media stripping to protect & seal
Product Marketing Manager, Stencil & Blast Tapes:
Mr. Louie Cobb
C: 800-628-8856; FAX: 803-376-5585
LCobb@Anchortape.com

Avion, Inc.

18077 Edison Avenue
Spirit of St. Louis Airport
Chesterfield, MO 63005
Universal Static Balance Fixture for helicopter rotor blades
Vice President: Mr. Joseph T. Buckel
C: 314-537-4900; FAX: 314-537-4660
jbuckel@avioninc.com
Vice President: Mr. Norm Beachum
C: 314-537-4900; FAX: 314-537-4660
nbeachum@avioninc.com

Basic Concepts, Inc.

1310 Harris Bridge Road
Anderson, SC 29621
Sentry line of patented custom size spill, leak & containment prod
General Manager: Mr. Glenn VanRomer
C: 800-285-4203; FAX: 864-224-7227
bci@carol.com
Business Development: Mr. Denny Middleton
C: 800-285-4203; FAX: 864-224-7227
bci@carol.com

Canadian Marconi Company

600 Dr. Frederik-Philips
Ville St-Laurent
Quebec Canada H4M 2S9
Communications, navigation and systems integration
Mgr., Marketing Services: Ms. Tina Verni
C: 514-748-3046; FAX: 514-748-3184
tverni@mtl.marconi.ca

Cessna Aircraft Company

One Cessna Boulevard
P. O. Box 7704
Wichita, KS 67215
Business and Utility Aircraft
Director, Government & Special Missions Sales: Mr. Patrick Sullivan
MAIL STOP: 533C
C: 316-517-8151; FAX: 315-517-8669
C33254@IBM.NET

Chandler Evans Control Systems Division

1 Charter Oak Blvd.
West Hartford, CT 06110
Fuel Controls, Fuel & Hydraulic Pumps, FADEC Systems
Marketing & Programs Director: Mr. Jack Mut
C: 860-523-2241; FAX: 860-232-1873
JMut@ChandlerEvans.com
Manager of Marketing and Programs: Ms. Laurie Tardif
C: 860-231-2726; FAX: 860-232-1873
LTardif@ChandlerEvans.com

Communications-Applied Technology

11250-14 Roger Bacon Drive
Reston, VA 20190-5202
Wireless ICS, Mil Headset Compatible, no airframe mod reqd.
President: Mr. G. Seth Leyman
C: 800-229-3925; FAX: 703-471-4428
info@c-at.com

DRS Photonics, Inc.

138 Bauer Drive
Oakland, NJ 07436
Multi-Platform Bore-sight Equipment/Digital Imaging
Camera Systems
Director, Business Development: Mr. Peter C. Connolly
C: 201-405-2925; FAX: 201-337-4775
connolly@drs.com

DRS Precision Echo, Inc.

3105 Patrick Henry Drive
Santa Clara, CA 95054
Manufacturing & support of audio and video recording products
Marketing Manager: Mr. Rene Chikhani
C: 408-988-0516; FAX: 408-727-7491
chikhani@drs.com

DuPont Company

P. O. Box 27001
Richmond, VA 23261
***Nomex & Kevlar brand fibers
Account Manager: Mr. Richard W. Blocker
MAIL STOP: P1L 1
C: 804-383-2984; FAX: 804-383-2009
richard.w.blocker-jr@usa.dupont.com

EXTEX, LTD., L.L.C.

6001 S. Power Road
Bldg. 15
Mesa, AZ 85206
Helicopter & Aerospace Engine Parts
Vice Chairman: Mr. Terry Capehart
C: 602-988-2000; FAX: 602-988-1012
tcapehart@ionet.net

Fastening Systems International, Inc.

P.O. Box 1372
1206 E. MacArthur Street
Sonoma, CA 95476
Blind rivet tool kits for Cherry Max, Rivnuts, and Blind Bolts
President: Mr. Roger Nikkel
C: 707-935-1170; FAX: 707-935-1828
sales@fsrivet.com

GE Aircraft Engines

1000 Western Avenue
Lynn, MA 01910
Manufactures and Services the T-700 Turboshaft
General Manager: Mr. Louis A. Bevilacqua
MAIL STOP: MZ 24004
C: 781-594-7617; FAX: 781-594-5891

(SEE OUR AD ON PAGE 43)

Gulfstream Aerospace Corporation

1000 Wilson Boulevard
Suite 2701
Arlington, VA 22209
C-20 (Gulfstream IV-SP) C-37 (Gulfstream V)
VP, Govt. Sales & Marketing: Mr. Monroe S. "Buddy" Sams
C: 703-276-9500; FAX: 703-276-9504
buddy_sams@mhsmail.gulfstream.com

Harris Corporation Electronic Systems Sector

P.O. Box 37
Melbourne, FL 32902-0037
Digital map, fiber-optics, sensor data distrib. network, IFCS
Marketing Communications Manager: Mr. Sleighton Meyer
MAIL STOP: MS 101/4751
C: 407-727-6514; FAX: 407-729-7246
SMEYER@harris.com

Hoffman Engineering Corporation

8 Riverbend Drive
P. O. Box 4430
Stamford, CT 06907-0430
Night Vision/Photometric Test Equipment/Aircraft Lighting
Marketing Administrator: Mr. Jack DeSoye
C: 203-425-8900; FAX: 203-425-8910
sales@HoffmanEngineering.com

ITT Avionics

100 Kingsland Road
Clifton, NJ 07014
Design & manufacture next-generation electronic counter-measures
Director, Electronic Warfare Marketing: Mr. Bob Palazzo
C: 973-284-2228; FAX: 973-284-4122
rpalazzo@avionics.it.com

(SEE OUR AD ON PAGE 11)

LORAD, a subsidiary of TREX Medical Corporation

36 Apple Ridge Road
Danbury, CT 06810
Industrial X-Ray equipment
Director, Industrial Marketing & Sales: Mr. Gerald Baur
C: 203-790-1188; FAX: 203-731-8458



WE'RE THE GUYS YOU WANT ON YOUR WING.

- A leading turboprop and jet service network
- Full-service depot facilities
- Complete inspection, maintenance and modification services
- Three complete paint and interior refurbishment facilities
- Avionics installations and repairs
- Component overhaul and parts

If you're putting a team together and need depot support, call Sheldon Early, our Vice-President of Business Development, at (864) 879-6000.

STEVENSAVIATION
Plane Smart.™

Atlanta • Dayton • Denver • Greenville • Nashville

©1998 Stevens Aviation, Inc.

Lucas Aerospace
1530 Wilson Blvd.
Suite 170
Arlington, VA 22209
Flight/Engine Controls, Elect. Power Generation, Cargo
Handling
Vice President, Government Relations, USA: Mr.
William "Bud" Orr
C: 703-465-9700; FAX: 703-465-9701
Director of Marketing: Mr. Ken Sanders
C: 703-465-9700; FAX: 703-465-9701
saundersken@msn.com

(SEE OUR AD ON PAGE 103)

Luminescent Systems, Inc.
101 Etna Road
Lebanon, NH 03766-1467
Electroluminescent Lighting, Formation Lights, Cockpit
Panels, NVG
Manager, Military Contracts: Mr. Manuel Medeiros
C: 603-448-3444, x3184; FAX: 603-448-3452
Project Engineer: Mr. James Patnode
C: 603-448-3444, x3124; FAX: 603-448-3452

B.E. Meyers & Co., Inc.
17525 NE 67th Ct.
Redmond, WA 98052
Night vision, laser illuminators, day/night cameras
V.P. Sales and Marketing: Mr. Roger Kreitzberg
C: 1-800-327-5648; FAX: 425-867-1759
meyers@bemeyers.com

NavCom Defense Electronics, Inc.
4323 Arden Drive
El Monte, CA 91731
Military radar altimeters, IFF test systems, and shipboard
TACANs
Director, Business Development: Mr. James P. Keller
MAIL STOP: ATTN: M/S 49
C: 626-579-8690; FAX: 626-444-7619
busdev@navcom.com

**Northrop Grumman Electronic Sensors and Systems
Division**
Post Office Box 746
Baltimore, MD 21203-7319
Key supplier of Longbow radars, missiles, sensors &
processors
Vice President, Longbow International Ltd.: Mr.
Eugene Thompson
MAIL STOP: MS 181
C: 410-993-7000; FAX: 410-765-5439
Eugene_H_Thompson@mail.northgrum.com

Northrop Grumman Electronic Systems
600 Hicks Road
Rolling Meadows, IL 60008
Military systems for precision strike to EW/ECM to test
support
Dir., Business Development & Strategic Planning: Mr.
Ray Petty
MAIL STOP: MS H6014
C: 847-259-9600; FAX: 847-870-5713
smtp.Ray_Petty@mail.northgrum.com

Orbital, Fairchild Defense
20301 Century Boulevard
Germantown, MD 20874
Armored Data, Solid State Drive, Mass Mem Unit,
Memory Data Module
Director, New Business Development:
Mr. Malcolm Quon
MAIL STOP: B-10
C: 301-428-6285; FAX: 301-428-6433
mquon@oscsystems.com
Sr. Director, Business Development: Mr. Jay Balakirsky
MAIL STOP: S-10
C: 301-428-6633; FAX: 301-428-6433
jbalakirsky@oscsystems.com

Photo-Sonics, Inc.
820 South Mariposa Street
Los Angeles, CA 91506-3196
Airborne Video Recorders, HUD Video Cameras, VCR
Software Control
Product Manager: Mr. John E. Nelson
C: 818-842-2141; FAX: 818-842-2610
mail@photosonics.com

Raytheon Aircraft Company
P.O. Box 85
Wichita, KS 67201-0085
Beech & Hawker aircraft - piston singles to medium sized
jets
Director, Government Aircraft Marketing: Mr. Lyn
Roberts
MAIL STOP: MS 187/B91
C: 316-676-8558; FAX: 316-676-6779
Lyn.Roberts@Raytheon.com

Raytheon Systems Company
1100 Wilson Boulevard
Arlington, VA 22209
Defense electronics
Director, Army Programs: Mr. Ronald K. (Andy)
Andreson
MAIL STOP: 19th Floor
C: 703-284-4435; FAX: 703-525-0370

Robertson Aviation, L.L.C.
P. O. Box 968
Tempe, AZ 85280
Crashworthy range extension fuel systems
President & General Manager: Mr. John R. Rawling
C: 602-967-5185; FAX: 602-968-3019
robertsonaviation@worldnet.att.net
Vice President, Marketing: Mr. Ian A. Powick
C: 602-967-5185; FAX: 602-968-3019
robertsonaviation@worldnet.att.net
Program Manager: Mr. Marshall L. Lewis
C: 602-967-5185; FAX: 602-968-3019
robertsonaviation@worldnet.att.net

(SEE OUR AD ON PAGE 13)

**Rockwell/Collins Avionics & Communications
Division**
350 Collins Road, N.E.
Cedar Rapids, IA 52498
Avionics, navigation & communications
Manager, Army Programs: Mr. Don Simpson
MAIL STOP: MS 120-131
C: 319-295-5783; FAX: 319-295-5111
dsimpso@caad.rockwell.com

(SEE OUR AD ON PAGE 104)

Rolin Industries, Inc.
P.O. Box 153
Lapeer, MI 48446
Windscreens, canopy & component part covers for heli-
copters
President: Ms. Linda Ross
C: 810-667-9445; FAX: 810-667-0048
sales@windshieldbuddy.com

(SEE OUR AD AT LEFT)

SCI Systems, Inc., Technology Division
P.O. Box 1000
Huntsville, AL 35807
Design/Manufacture avionics, communication and proces-
sor systems
Business Development Manager: Mr. Floyd Raynard
MAIL STOP: MS 240
C: 256-882-4792; FAX: 256-882-4652
floyd.raynard@scismail.sci.com



Windshield Buddy for military helicopters are government approved covers made of durable fiber re-enforced outer shell with a scratch resistant pro-
tective liner. Protects windscreens & component parts from environmental elements
such as sand, sun and stones thrown from helicopter blades as well as ice and
snow. The **UH-60 Black Hawk Mechanic's Canopy** featured, is easily installed
gives shade for mechanic in extreme heat climate. The **MH-47E Chinook Canopy**
featured (Jettison doors now included under canopy not shown). Also featured is
the **AH64-A Apache canopy**. Easily stowed on board in their own containers. We
ship worldwide. Visa/MC accepted. "Patent Pending." All Rights Reserved.

Rolin Industries, Inc., PO Box 153, Lapeer, MI 48446
Tel: (810)667-9445, Fax: (810)667-0048, E-Mail: sales@windshieldbuddy.com
Webb: www.windshieldbuddy.com

SEI Industries
7400 Wilson Avenue
Della, BC, Canada V6G 1E5
R&D & Mfg of Aviation, Fire Suppress, Exploration &
Environmt Prod
Product Manager, Aerial Firefighting: Mr. Rob Ferguson
C: 604-946-3131; FAX: 604-940-9566
rob@sei-ind.com

(SEE OUR AD AT RIGHT)

Sierra Technologies, Inc.
485 Cayuga Road
Buffalo, NY 14225
Producer/integrator of EW threat emitters for worldwide
deployment
Marketing Manager: Mr. Paul W. McGillick
C: 716-631-6200; FAX: 716-631-7849

Simula Safety Systems, Inc.
7414 S. Harl Avenue
Tempe, AZ 85283-4307
Aircraft airbags, ballistic armor, crashworthy aircraft seats.
Product Manager, Military Seat Systems: Mr. Jack Cress
C: 602-730-4406; FAX: 602-897-1906
jcress@simula.com

(SEE OUR AD ON PAGE 61)

Staveley NDT Technologies
421 No. Quay Street
Kennewick, WA 99336
Nondestructive testing equipment for UT, EC, X-Ray,
Composites
Sales Manager: Mr. Keith Erickson
C: 509-735-7550; FAX: 509-735-4672
snd11@staveleyndt.com

UP TO THE CHALLENGE!



The **BAMBI BUCKET®** helicopter aerial delivery system is **Initial Attack Ready!**

In over 81 countries and throughout the USA, the **BAMBI BUCKET®** is the **Weapon of Choice** of fire agencies, both military and civilian worldwide.

The **BAMBI BUCKET®** is available in 19 models up to 5,200 US G and is engineered for fast, easy, and independent interface to allow your airwing complete multi-mission capability at all times.

www.sei-ind.com

E-mail: sales@sei-ind.com

Tel: (604) 946-3131 Fax: (604) 940-9566

SEI
INDUSTRIES

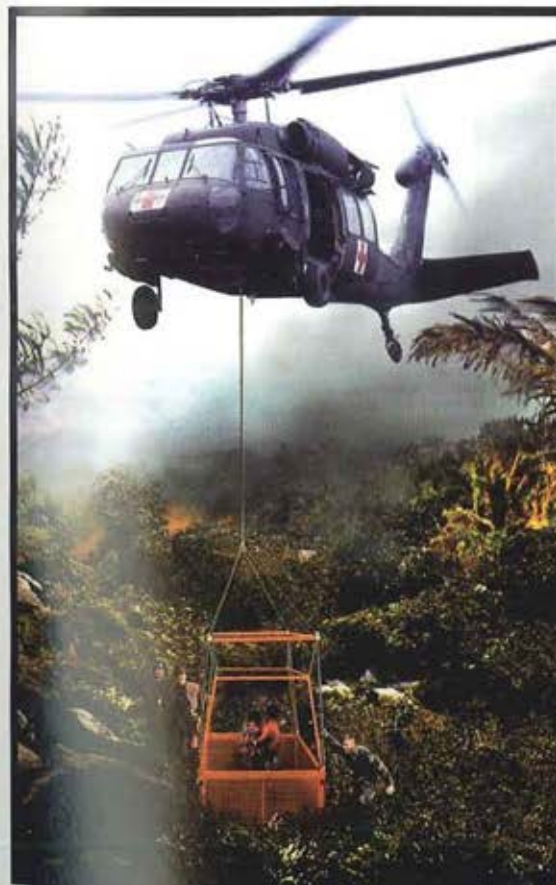

HELI-BASKET™

U. S. Patent 5,344,203

**THE MOST ADVANCED, VERSATILE,
MULTI-PURPOSE DELIVERY SYSTEM
IN THE WORLD**

- SINGLE EVENT MULTIPLE RESCUE CAPABILITY
(UP TO 15 PERSONS AT A TIME), LAND OR SEA
- RESCUE AND SUPPLY STATION
- RELIABLE CRITICAL SUPPLY AND ROUTINE DELIVERY TOOL
- STABLE INFLIGHT DELIVERY PLATFORM, LOADED OR EMPTY
- LARGE OPEN FLOOR AREA ACCOMODATES PALLETIZED CARGO
- RUGGED CONSTRUCTION—ENGINEERED TO 3.75 G's
WITH A 4500LB PAYLOAD
- GSA CONTRACT NO. GS-07F-9893H

***SURVIVABILITY REQUIRES THE BEST ADVANTAGE
IMPORTANT MISSIONS DESERVE
THE BEST EQUIPMENT AVAILABLE***

Precision Lift Inc
94 Sun Mountain Drive
Monarch, Mt 59463

Phone/Fax 406-236-5361
email sunmtn@3rivers.net
www.precision.rotor.com

Life Support Equipment

MA-16 Inertia Reel

Provides impact protection with both strap acceleration and three-axis vehicle sensitivity. QUALIFIED to Mil-R-8236F and ready to INSTALL.



Restraint Systems



Single point release on dynamically qualified 4 or 5 point harness. Ready for use in helicopter crew, troop and air ambulance attendant seat.

Emergency Lighting

For both helicopter and fixed wing use. Activated by loss of A/C power, water or impact sensors. Qualified to Mil-L-85676(AS) and ready to install.



Visit our web site at <http://www.hkoch.com> to learn more about our vacuum packaging, water activated life preservers & anti-drown devices and parachute canopy releases.



H. Koch & Sons Co.

5410 E. La Plama Ave.
PO Box 68005
Anaheim, CA 92807-2099
TEL (714) 779-7000
FAX (714) 779-7141

e-mail: sales@hkoch.com

Telephonics Corporation
815 Broad Hollow Road
Farmingdale, NY 11735
Supplier of information and communications systems
Corporate V.P. Business Management: Mr. Richard Hartig
MAIL STOP: Mail Stop #38
C: 516-755-7158; FAX: 516-755-7010
RHARTIG@TELEPHONICS.COM

Varo L.L.C.
2800 West Kingsley Road
Garland, TX 75041
Power Supplies, Converters, Battery Monitors/Cond.
Marketing Manager: Mr. Emery Seaman, Jr.
C: 972-840-5531; FAX: 972-840-5151

Vickers Inc., TEDECO Division
24 E. Glenolden Avenue
Glenolden, PA 19036
Rotorcraft lube systems debris monitors & level sensing equipment
Director of Marketing and New Business Development: Mr. Edward Demas
C: 610-583-9400, x247; FAX: 610-583-3985
ED.DEMAS@VICKERS-SYSTEMS.COM
(SEE OUR AD ON PAGE 53)

MAINTENANCE/REPAIR/OVERHAUL

Arctic Slope World Services (ASWS)
3033 Gold Canal Drive
Rancho Cordova, CA 95670
On-site aircraft maintenance & refueling support
Mgr. Aviation Maintenance Services: Mr. Dave Sadlosky
C: 916-363-2224; FAX: 916-363-7488
daves@arcticworld.com

Boeing Sikorsky Aircraft Support
P.O. Box 550
Fort Campbell, KY 42223-0550
Provide Aviation Logistics Support Services
General Manager: Mr. John S. "Steve" Bolton
C: 502-439-6232, x309; FAX: 502-439-0961
Deputy General Manager: Mr. Kurt J. Porter
C: 502-439-6232, x328; FAX: 502-439-0961
kurt.porter@OKC.boeing.com

Composite Technology, Inc.
1001 Avenue R
Grand Prairie, TX 75050
Overhaul of helicopter M/R and T/R Blade: Apache cowling repairs
Customer Support: Ms. Renee Wilson
C: 214-606-4400; FAX: 214-606-4418
ras_cli@compuserve.com

Corrosion Technologies Corporation
P. O. Box 551625
Dallas, TX 75355-1625
CorrosionX Aviation
Military Manager: CW4, Ret. Lewis Graytok
C: 972-271-7361; FAX: 972-278-9721
CORROSNX@ix.netcom.com

DynCorp Aerospace Technology
6500 West Freeway, Suite 600
Fort Worth, TX 76116
Technology solutions & support services to government & industry
President: Mr. Robert B. Allegger
C: 817-737-1522; FAX: 817-737-1505
allegger@dyncorp.com
Sr. VP, Business Development: Mr. Albert J. Konvicka
C: 817-737-1662; FAX: 817-737-1604
konvicka@dyncorp.com
Division Manager - Ft. Rucker, AL: Mr. Thomas Walker
C: 334-598-0401; FAX: 334-598-0430
WalkerT@prismplus.com

Director, AT - Ft. Worth, TX: Mr. Pat Oler
C: 817-737-1569; FAX: 817-737-1604
olerp@dyncorp.com

Director, AT - Ft. Hood, TX: Mr. Terry Reininger
C: 817-737-1670; FAX: 817-737-1601
reiningt@dyncorp.com

Site Manager - Ft. Hood, TX: Mr. Harry Frazier
C: 817-532-8200; FAX: 817-532-5211
frazierh@dyncorp.com

Director, ATTC - Ft. Rucker, AL: Mr. Jimmy Wood
C: 334-598-0550; FAX: 334-255-8038
wood@rucker-emh1.army.mil

Site Manager - Heidelberg, Germany: Mr. Martin "Rip" Ayers
C: 011-4962-1473511; FAX: 011-4962-1479825
mayers@hq.amceur.army.mil

Site Manager - Korean Offices: Mr. Steven Safriet
C: 011-823336907; FAX: 011-823336914942
safriets@usfk.korea.army.mil

Site Manager - Ft. Campbell, KY: Mr. Jim Ellis
(SEE OUR AD ON PAGE 9)

Helicomb International, Inc.

1402 S. 69th E Avenue
Tulsa, OK 74112
Overhaul & repair helicopter bonded, composite panels
Helicopter Repair Division Manager: Mr. Joe Donahue
C: 918-835-3999; FAX: 918-834-4451
Joe.D@helicomb.com

(SEE OUR AD ON PAGE 85)

Kaman Aerospace Corporation

P.O. Box 2, Old Windsor Road
Bloomfield, CT 06002
K747 MRB Overhaul/Support/Remanufacture for the AH-1 Cobra
Marketing Manager: Mr. Jeffrey E. Sharbaugh
MAIL STOP: BLD 31
C: 860-243-7380; FAX: 860-243-7043
SHARBAUGHJ-KAC@KAMAN.COM

Kay and Associates, Inc.

3820 N. Ventura Drive
Arlington Heights, IL 60004-7951
Engr, tech, log svc in opr, maint, mod, cal of aircraft, avn sys. ISO9002
VP, Business Development: Mr. Wayne Kirkpatrick
MAIL STOP: NBD
C: 800-323-4181; FAX: 847-255-8451
kainbd@kayinc.com

Lear Siegler Services, Inc.

175 Admiral Cochrane Drive
Annapolis, MD 21401
Logistics, maintenance, modifications, training & sys. integration
General Manager, CFT: Mr. Dave Carothers
C: 405-424-5551; FAX: 405-424-3567
David_carothers@learinc.com

National Airmotive Corporation

7200 Earhart Road
Oakland, CA 94621
Mainl., O/H & Field Svc. on A-250, PT6 eng & MD500 components
V.P., Light Turbines: Mr. Fredrik Groth
C: 510-613-1024; FAX: 510-635-2250
reliability@naccorp.com

Raytheon Aerospace Company, Contract Field

Teams
4600 SE 29th, Suite 500
Del City, OK 73115-3429
Quick response mission support maintenance/modification worldwide
General Manager, CFT: Mr. Clark Estes
C: 405-677-1300; FAX: 405-677-4516

(SEE OUR AD ON PAGE 25)



TRI-MAX 30 standing guard at Molinelli Range. Ft. Rucker's Molinelli Range Complex is now equipped with state of the art fire suppression systems, TRI-MAX 30. In today's high tech aviation environment the ability to prevent, control and extinguish a fire is a critical asset for the aviation field commander. Never before has there been anything like the TRI-MAX 30. This highly mobile fire suppression system injects stored compressed air, both to propel the foam solution and produce the high energy-foam. The TRI-MAX CAF Systems yield expansion ratios adjustable in the optimal 10:1-20:1 range and beyond, with stream projections equaling or exceeding water. The foam produced by a TRI-MAX System maximizes availability of water in a Aqueous Film Forming Foam for conversion to stream. The foam clings to all potential fuel surfaces both horizontal and vertical. The foam super cools and humidifies the environment providing an island of protection. Once applied, high-energy foam produced by the TRI-MAX System keeps things "too damp to burn". In short the TRI-MAX System uses 29 gallons of water and 1 gallon of AFFF to produce approximately 600 gallons of high energy foam and projects it 75 ft. TRI-MAX in conjunction with CHEMGUARD INC have recently developed and tested a new -40 Degree Arctic Foam (AFFF). This is the first product to provide the capability to produce high energy foam in sub zero degree temperatures. In recent test the TRI-MAX 30 was filled with the new -40 Degree Foam. It was then placed in a freezer and cooled to a minus 39-40 degrees centigrade for 16 hours. A 50 square foot fire pan filled with 50 gallons of heptane was ignited and allowed to burn for 60 seconds. The foam was applied to the backboard and allowed to flow back over the burning fuel. Control was obtained in 45 seconds and extinguishment occurred in 55 seconds. To determine the total discharge time, foam was discharged until the tank was empty; a total of 180 seconds and a reach in excess of 30 feet. This represents the first and only high energy foam product available for use in sub zero temperatures for non-polar fuel fires. A major break through in fire fighting capability. TRI-MAX is leading the way in fire suppression technology. The new Arctic Foam will have an NSN and be available from GSA sometime in September 1998. These and other TRI-MAX products are available from GSA or Stanley Manufacturing, 4401 India Ave., Redding, CA. 96003, Ph. (530) 275-3621, Fax (530) 275-2501.

(Paid Advertisement)

CONSULTANT/SPECIAL SERVICES

ARINC Incorporated

2551 Riva Road
Annapolis, MD 21401
Aviation communications and systems integration
Director, Huntsville Operations: Mr. Albert J. Boyer
C: 205-922-1022; FAX: 205-922-1026
abooyer@arinc.com

(SEE OUR AD ON PAGE 63)

Avion, Inc.

4970 Corporate Drive, Suite 100A
Huntsville, AL 35805
Engineering; Test Management; RAM; Database Services
President: Mr. Gary W. Donald
C: 256-721-7006; FAX: 256-721-7007
gdonald@avioninc.com

COBRO Corporation

6767 Old Madison Pike, Suite 195
Huntsville, AL 35806
Award winning material return Prg/generating credit
for mgt plan.
Program Manager: Mr. Donald Van Name
C: 256-922-0003, x213; FAX: 256-922-0032
dvanname@cobrohsv.com

Computer Systems

International, Inc. (CSI)
1100 Executive Boulevard
Chesapeake, VA 23320
Leading provider of LANS, WANS, Computer
Hardware, Software & Svcs.
President: Mr. Thomas C. Pool
C: 757-436-1535; FAX: 757-436-0896
tcpool@csiint.com
Vice President Business Development: Major
General, Ret. Harold I. Small
C: 757-436-1535; FAX: 757-436-0896
hismall@csiint.com

Global Helicopter Technology, Inc.

5070 South Collins Street, Suite 206
Arlington, TX 76018-1108
Engr. R&D, A/C Mods, Testing, Instrumentation, &
Certif./Qualif.
President: Mr. Chuck Larson
C: 817-557-3391; FAX: 817-557-3392
ghl@airmail.net
Director, Business Development: Mr. Charles H. Cole
C: 817-557-3391; FAX: 817-557-3392
ghl@airmail.net

Nations, Inc.

788 Shrewsbury Avenue
Tinton Falls, NJ 07724
Information Management, S/W, H/W, Communications
Engineering Svcs.
Director, Business Development: Mr. Richard G. Sousa
C: 732-530-1818; FAX: 732-747-7138
dsousa@nationsinc.com

Navigator Development Group, Incorporated

116 S. Main Street
P. O. Box 310069
Enterprise, AL 36331-0069
Research, Analysis, Management & Defense Consulting
President: Mr. Albert L. Patterson, III
C: 334-347-7612; FAX: 334-347-2582
ndgialp@snowhill.com

Peduzzi Associates, Limited

219 North Washington Street
Alexandria, VA 22314
Aerospace Business Development and Government
Relations
President: Mr. Lawrence P. (Pete) Peduzzi
C: 703-836-7990; FAX: 703-836-9739
PALBUSDEV@AOL.COM

Teledyne Brown Engineering

300 Sparkman Drive, N.W.
Huntsville, AL 35805
Modeling & Simulation, Engineering Services, Systems
Engineering
Director of Tactical Programs: Mr. Tim Kraatz
MAIL STOP: 160
C: 256-726-3684; FAX: 256-726-3909
tim.kraatz@pobox.tbe.com

Vitronics, Inc.

15 Meridian Road
Eatontown, NJ 07724
Air/Ground C2 R&D support, software/hardware dev.,
prototyping
President: Mr. Michael A. Cinque
C: 732-389-0244, ext 17; FAX: 732-389-8708
mcinque@vitronics.com
Director, Regional Operations: Mr. James Stewart
C: 732-544-8220; FAX: 732-544-8397
stewartj@doim6.monmouth.army.mil

Wyle Laboratories

PO Box 07777
7800 Highway 20 West
Huntsville, AL 35806
Systems & Sub-systems testing services
Dir., Program Development: Mr. Dave Dougherty
C: 256-837-4411, x373; FAX: 256-830-2689
davidd@hnl.wylelabs.com

(SEE OUR AD ON PAGE 51)

Attention Junior Military Officers:

If you're leaving the military
with brand new goals, let us
show you how to reach them.

If you are a proven leader and are seeking greater challenges, then a
career as a Merrill Lynch Financial Consultant may be for you. You can
bring to the position the best product you have: Yourself, your abilities,
experience, talents, and leadership experience.

A career as a Merrill Lynch Financial Consultant offers many benefits,
including:

- High income potential
- Affiliation with a leading Fortune 500 organization
- Flexibility to work in virtually any location you choose

And more.

Let us show you a superb way to reach your goals. If you are interested
in becoming a Merrill Lynch Financial Consultant or would like more
information on our upcoming career days, mail or fax your resume to:

Joseph N. Hébert, III, Vice President
Merrill Lynch
P.O. Box 9000
Princeton, NJ 08543-9000
Phone: 1-800-759-BULL
Fax: 609-282-1777

DATES:

Saturdays, October 24th, 1998 and, January 9, 1999

PLACE:

Merrill Lynch Conference Center
Plainsboro, NJ

Women and minorities are encouraged to apply.



Merrill Lynch

Merrill Lynch is an Equal Employment Opportunity Employer.

© 1998 Merrill Lynch, Pierce, Fenner & Smith Incorporated. Member SIPC.

WE'RE AT YOUR SERVICE



USAA AUTO INSURANCE
FOR MILITARY PERSONNEL

For 75 years we have been providing quality auto insurance at competitive rates to military members.* Frankly, we know how to serve the insurance needs of the military.

If you want to be sure you're getting the lowest rates and the best service possible for auto insurance, you need to give us a call.

- **Very Competitive Rates**
- **No Policy or Membership Fees**
- **Superior Claims Handling**
- **Highest Industry Ratings**
- **Flexible Payment Plans**



* In addition to serving officers and their families, USAA now offers auto insurance to active duty, National Guard and Selected Reserve enlisted personnel in selected states and overseas locations opening throughout 1998. Active duty, National Guard, and Selected Reserve military personnel and their families as well as former USAA policyholders are eligible to apply for property and casualty insurance with USAA. Retired and inactive military personnel who never established USAA membership by purchasing a property and casualty insurance policy are not eligible.

JOIN FORCES WITH USAA!SM
1-800-292-8449

THE 1998 BLUE BOOK INDEX

A Co, 1-189th CSAB	64	3d Battalion, 101st Aviation Regiment	58	159th Medical Company (AA)	76
1-124th Cavalry Squadron	72	3d Squadron, 6th Cavalry	80	160th Special Operations Avn Regiment (Airborne)	56
1-285th Aviation Attack Battalion	42	3d Squadron, 17th Cavalry	66	164th Air Traffic Services Group	79
1-189th CSAB	64	3rd Squadron (Recon), 4th U.S. Cavalry	54	207th Aviation Comp., ODCSOPS, USAREUR	77
1-168th Theater Army Aviation	75	3-137 Assault Helicopter Battalion	68	211th Aviation Group	72
1/151 Aviation (Advanced Attack Helicopter)	70	3-147 Aviation Regiment (Attack)	62	224th Military Intelligence Bn (Aerial Exploitation)	50
1-501st Attack Helicopter Battalion	77	4th Brigade, 1st Armored Division	77	229th Aviation Regiment (Airborne)	68
18th Aviation Brigade	67	4th Battalion, 160th Special Oprns. Avn Reg (Airborne)	56	236th Medical Company	78
1st Battalion, 11th Aviation Regiment	30	4th Brigade (Avn), 4th Infantry Division (MECH)	71	244th Aviation Brigade	54
1st Aviation Brigade (Air Assault)	32	4th Brigade (Avn), 1st Cavalry Division	71	341st Medical Battalion (EVAC)	72
1st Battalion (Attack), 10th Aviation Reg.	66	4th Brigade, 1st Infantry Division	78	404th Support Battalion (Aviation)	71
1st Battalion, 145th Aviation Regiment	32	4th Battalion, 123d Aviation	42	416th ATSC (DIV)	44
1st Battalion, 109th Aviation Reg. (AVIM)	54	4th Squadron, 7th Cavalry Regiment	79	449th Aviation Group	68
1st Squadron, 167th Cavalry	64	4th Squadron, 3rd Armored Cavalry Reg	46	498th Medical Company (Air Ambulance)	50
1st Battalion, 229th Aviation Regiment	68	4th Battalion, 101st Aviation Regiment	58	507th Medical Company (Air Ambulance)	72
1st Battalion, 223rd Aviation	32	4th Squadron, 2nd Armored Cavalry Reg	60	542d Medical Company	79
1st Battalion, 222nd Aviation Regiment	75	5th Battalion, 158th Aviation Regiment	78	571st Medical Company (Air Ambulance)	46
1st Battalion, 169th Aviation	46	5th Battalion, 159th Aviation Regiment	74	603d Aviation Support Battalion	52
1st Battalion, 13th Aviation Regiment	32	5th Battalion, 101st Aviation Regiment	58	681st Medical Company (Air Ambulance)	54
1st Battalion, 2nd Aviation Regiment	79	5th Battalion, 501st Aviation Regiment	80	717th Medical Company, Detachment 1	64
1st Battalion, 159th Aviation Regiment	67	6th Cavalry Brigade	80	832d Medical Company	76
1st Squadron (AIR), 17th Cavalry Regiment	67	6th Squadron (Attack), 6th Cavalry	77	1106th Avn Class. Repair Activity Depot (AVCRAD)	44
1st Battalion, 108th Aviation Reg. (Assault)	56	6th Battalion, 101st Aviation Regiment	58	1107th Avn Class. Repair Activity Depot (AVCRAD)	64
1st Squadron, 10th Cavalry	71	7th Battalion, 101st Aviation Regiment	58	1108th Avn Class. Repair Activity Depot (AVCRAD)	62
1st Battalion, 52nd Aviation	79	7th Battalion, 159th Aviation Regiment	77	1109th Avn Class. Repair Activity Depot (AVCRAD)	46
1st Attack Helicopter Bn, 25th Aviation Reg.	52	7th Squadron, 6th Cavalry Reg (ATKHB)	70	1022d Medical Company	76
1st Attack Helicopter Battalion	67	7th Army Training Comm., Avn Detachment	77	1022d Medical Company, Detachment 1	46
1st Battalion, 160th Special Oprns. Avn Reg (Airborne)	56	8th Battalion, 229th Aviation Reg (Attack)	60	1085th Medical Company	70
1st Battalion, 150th Aviation	65	8th Battalion, 101st Aviation Regiment	56	Acquisition Center, USAAMCOM	38
1st Battalion, 149th Aviation Regiment	72	9th Battalion, 101st Aviation Regiment	58	Aeroflightdynamics Directorate, USAAMCOM	44
1st Battalion, 101st Aviation Regiment	58	10th Aviation Brigade, 10th Mountain Div. (Light)	66	Air-to-Ground Missile Sys Integration Office	36
1st Military Intelligence Bn, (Aerial Exploitation)	76	11th Aviation Regiment	77	Air-to-Ground Missile Systems Project Office	36
1st Battalion, 207th Aviation Regiment	42	12th Aviation Brigade	76	Air Maneuver Battle Lab Directorate, USAAVNC	28
1st Attack Battalion, 4th Aviation Regiment	71	12th Aviation Battalion	74	Air Traffic Control (ATC) Product Office, USAAMCOM	38
1st Attack Helicopter Bn, 3rd Aviation Regt	52	17th Aviation Brigade	79	Air Defense Missile Directorate, (IMMC), USAAMCOM	40
1st Squadron, Seventh Cavalry	71	XVIII Airborne Corps Aviation Office	67	Airborne Com. Branch, CCS/Avionics Direct., CECOM	65
1st Aviation Training Battalion	60	21st Cavalry Brigade (Air Combat)	71	Airborne Navigation Branch, CCS/Avionics Directorate, CECOM	65
1st Battalion, 58th Avn Reg (Corps) (Airborne)	67	24th Medical Company (Air Ambulance)	64	Airborne Mission Division, CCS/Avionics Directorate, CECOM	65
1st Squadron, 6th Cavalry	80	25th Infantry Division (Light) Aviation Brigade	52	Airborne NAVCOM Division, CCS/Avionics Directorate, CECOM	65
1st Battalion, 212th Aviation Regiment	32	28th Infantry Div, Aviation Bde, Penn. ARNG	69	Aircraft Survivability Branch, CCS/Avionics Directorate, CECOM	65
1st Battalion, 14th Aviation Regiment	30	29th Aviation Brigade	62	Aircraft Programs Branch, CCS/Avionics Directorate, CECOM	65
1st Battalion, 210th Aviation Regiment	32	34th Infantry Div. Avn Bde, Minnesota ARNG	62	Aircrew Integrated Systems PM's Office	34
1st Battalion, 142d Aviation Reg, NYARNG	66	35th Aviation Brigade	64	Apache Modernization Product Mgmt Office	36
1st Battalion, 227th Aviation Regiment	71	36th Medical Evacuation Battalion	71	Apache Attack Helicopter PM's Office	36
1st Battalion, (Attack) 1st Aviation Reg	78	36th Medical Detachment (Helicopter Ambulance)	60	Apache Div., Acquisition Center, USAAMCOM	40
1st Battalion, 147th Aviation	76	38th Attack Regiment	44	Arctic Support Brigade	40
2-104th Aviation Battalion (GSAB)	69	40th Infantry Div. Avn Bde, California ARNG	44	Army Aviation Division, ODCSOPS	46
2-147 Aviation Regiment (Assault)	62	42d Aviation Brigade	66	Army Aviation & Safety Div., National Guard Bureau	74
2/98th Troop Command	42	45th Medical Company	78	Army Flight Operations Detach. (AFOD), ODCSOPS	76
2-502d Aviation Regiment	76	47th ATS Company	62	Army Aviation Support Facility #2	42
2d Battalion, 159th Aviation Regiment	67	49th Armored Division Aviation Brigade, HHC	70	Atlanta Regional Flight Center	50
2d Battalion (Assault), 82d Aviation Regiment	67	49th Armored Division Avn Bde, Co H, 149th Aviation	72	Australian Liaison Office	32
2d Squadron (Attack), 6th Cavalry	77	49th Armored Division Aviation Brigade	70	Aviation Branch, Trng. Spt. Mgt. & Ex. Div., DCST, First U.S. Army	50
2d Squadron, 17th Cavalry	58	49th Armored Division Avn Bde, Co F, 149th Aviation	70	Aviation/Ground Safety, Fifth USA	72
2d Battalion, 101st Aviation Regiment	58	50th Medical Company (Air Ambulance)	56	Aviation Division, Operations Group, JRTC	60
2d Battalion (Assault), 2d Aviation Regiment	79	56th Medical Evacuation Battalion	67	Aviation Office, V U.S. Corps	76
2d Battalion, 160th Special Oprns. Avn Reg (Airborne)	56	57th Medical Company (Air Ambulance)	68	Aviation Div., Individual Training Dir., DCS of Training, TRADOC	75
2d Battalion, 228th Aviation Regiment	69	63rd Aviation Group	60	Aviation Div., Direct. of Oper., DCSOPS, FORSCOM	50
2d Battalion, 3d Aviation Regiment	52	66th Aviation Brigade (Corps)	75	Aviation Division, ODCSOPS, USARC	50
2d Battalion, 126th Avn. Regiment	46	68th Medical Company (AA) Alaska	42	Aviation Electronic Combat PM's Office	36
2nd Battalion, 227th Aviation Regiment	71	78th Aviation Battalion (Provisional)	80	Aviation Div., DPTM, Simmons Army Airfield	67
2nd Battalion, 149th Aviation Regiment	72	82d Aviation Brigade	67	Aviation Division, Fifth U.S. Army	72
2nd Battalion, 501st Aviation Regiment	77	101st Airborne Division (AASLT) Aviation Bde	56	Aviation Brigade, 3rd Infantry Division	50
2nd Battalion, 10th Aviation Regiment	66	101st Airborne Division (Air Assault)	56	Aviation Support Facility Lewis	75
2nd Battalion, 1st Aviation Regiment	78	112th Medical Company (AA)	60		
2nd Battalion, 52nd Aviation Regiment	80	121st Medical Company (AA)	46		
2nd Assault Helicopter Bn, 25th Avn Reg	54	126th Medical Company (AA)	44		
2nd Battalion, 4th Aviation Regiment	71	127th Aviation Support Battalion	78		
3d Battalion, 229th Aviation Regiment	68	146th Aviation Group (Combat)	64		
3d Battalion, 160th Special Oprns. Avn Reg (Airborne)	58	148th Medical Company (AA)	52		
3d Battalion, 58th Aviation Regiment (ATS)	76	159th Aviation Brigade (Assault)	58		

BEST VALUE



Raytheon Aerospace Company provides quality worldwide support through its Contract Field Teams (CFT) - from aircraft and vehicle performance upgrades to battle-area maintenance and logistics. Raytheon Aerospace is ready to dispatch diversified, quality technicians to perform depot maintenance, field maintenance, and modification on-site for aircraft, engines, electronics, missiles, support equipment, tanks, vehicles, and other military systems.



Usually a CFT can be directed to a work site in a matter of hours after Delivery Order Notification. Raytheon Aerospace CFT offers a responsive, cost-effective way to modify or maintain today's military equipment and systems.

Contract Field Team Operations

4600 S.E. 29th Street, Suite 500
Del City, Oklahoma 73115-3429
Telephone 405-677-1300
or 800-788-8101
Fax 405-677-4516

Raytheon Aerospace Company

555 Industrial Drive So. ♦ Madison, MS 39110
Telephone 601-856-2274 ♦ Fax 601-856-8006

<http://members.aol.com/raycft/raycft.html>

Aviation Branch, OPMD, U.S. Total Army PERSCOM . . . 73	Directorate of Logistics, USAAVNC 28	Plans, Require. & Strategic Assessments, J-7, USSOCOM . . . 48
Aviation Section, U.S. Army Electronic Proving Ground . . . 42	Directorate of Information Mgmt, USAAVNC 28	Plans Division, ODCSPER 48
Aviation Oper. Branch, Army Avn. & Safety Div., NGB . . . 74	Directorate of Human Resources, USAAVNC 28	Plans Logistics, Operations & Training (PLOT) Div. 50
Aviation Office, Eighth U.S. Army 79	Directorate of Plans, Training, Mobilization & Security, USAAVNC 28	Plans & Operations Div., Dir., of Health Care Oper., OTSG 74
Aviation Applied Technology Direct., (AATD), USAAMCOM 75	Directorate of Evaluation & Standardization, USAAVNC 28	PM, Instrumen. Targets & Threat Simul., (ITTS), STRICOM 48
Aviation Support Facility Orlando 48	Directorate of Community & Family Activities, USAAVNC 28	PM, Warfighters' Simulation (WARSIM), STRICOM . . . 48
Aviation Management Branch, OPMD, TAPC 73	Directorate for Supply & Maint., ODCSLOG 48	PM, Combat Supp. Training Sys (CSTS), STRICOM . . . 48
Aviation Research, Develop. & Eng. Center, USAAMCOM 38	Directorate for Business Management, USAAMCOM . . . 40	PM, Ground Combat Training Sys (GCTS), STRICOM . . . 48
Aviation Engineering Directorate, USAAMCOM 38	Directorate of Combat Developments, USAAVNC 28	PM, Air & Command Training Sys (ACTS), STRICOM . . . 48
Aviation/IEW Directorate, OASARDA 46	Directorate of Resource Mgmt, USAAVNC 28	Program Executive Office, Avn 34
Aviation Logistics Division, ODCSLOG, HQDA 48	Directorate of Training, Plans and Evaluation, USAALS . 75	PM, Combined Arms Tactical Trainer (CATT), STRICOM . . 50
Aviation & Missile RDEC Directorate, Acquisition Center, USAAMCOM 40	Directorate of Training, Doctrine & Simulation, USAAVNC 28	PM, Training Devices (TRADE), STRICOM 48
Aviation Office, ODCSOPS, USAREUR 76	District of Columbia ARNG Army Avn Support Facility . . 74	Public Affairs Office, USAAVNC 30
Aviation Office, USATECOM 32	Division Support Command (DISCOM) 56	Public Affairs Office, USAAMCOM 36
Aviation Office, U.S. Army Alaska (USARAK) 42	E Company, 1-189th Aviation Battalion 42	Ray S. Miller Army Airfield 62
Aviation Office, U.S. Army Materiel Command (USAMC) 73	Eastern Army Nat'l Guard Aviation Training Site (EAATS) 69	Readiness Directorate, (IMMC), USAAMCOM 40
Aviation Test Directorate, USATEXCOM 72	Enhanced Fiber Optic Guided Missile Project Office, USAAMCOM 38	Requirements Directorate, ADCSOPS for Force Development, ODCSOPS 46
Aviation Evaluation Directorate, U.S. Army OPTEC . . . 73	F Company, 147 Aviation Regiment (AVIM) 62	Safety Division, USATECOM 62
Aviation Logistics Sup. Dir., Acquisition Ctr, USAAMCOM 40	Fire Control Radar Product Manager's Office 36	Safety Office, U.S. Army Materiel Command (USAMC) . 73
Aviation Sys Directorate, (IMMC), USAAMCOM 40	Fixed Wing Product Office, USAAMCOM 38	Scout/Attack Team, Army Aviation Division, ODCSOPS . . 48
Aviation Staff Officer 46	Fixed Wing ARNG Aviation Training Site (FWAATS) . . 75	Scout/Attack Product Office, USAAMCOM 38
Aviation Office, U.S. Army Medical Command 72	Flight Test Directorate, U.S. Army Aviation Technical Test Center 34	Small & Disadvantaged Bus. Utilization Office, USAAMCOM 38
Aviation Logistics & Integration Planning Group, USAALS . 74	Fort Hood Regional Flight Center 71	Smart Weapons Management Office, USAAMCOM 38
Aviation/Transportation Branch, EPMD, TAPC 73	Fort Belvoir Regional Flight Center 74	Special Management Division, TAPC 73
Aviation Support Facility Dobbins 50	French Liaison Office 32	Stinger (SHORAD) Product Office 38
Aviation Brigade, 2d Infantry Division 80	G Company, 58th Aviation Regiment (ATS) 52	Support Team, Army Aviation Div., ODCSOPS 46
Aviation Systems Branch, Army Avn & Safety Div., NGB 74	German Army Liaison Staff USA 5 32	Systems Acquisition Air Dir., Acquisition Ctr, USAAMCOM 40
Aviation Branch Personnel Proponery Office (AP) 28	HAWK Weapon System Manager, WSD, USAAMCOM 38	Systems Acquisition Missile Dir., Acquis. Ctr, USAAMCOM 40
Aviation Planning Group, USAAVNC 28	Helicopter School Battalion 30	T800 Product Manager's Office 36
Aviation Electronic Combat Team, USAAVNC 30	Henry Post Army Airfield 68	Test, Measurement & Diagnostic Equipment Program Office, USAAMCOM 38
Aviation Training Brigade 30	HHC 1-189th CSAB 64	TRADOC System Manager for Comanche 30
Aviation Sys Test Div., Avn Test Direct, USATEXCOM . 72	High Altitude Training Site (HATS) 46	TRADOC System Manager (TSM) for Longbow (LB) . . 30
Aviation Support Facility Olathe 56	Hunter Army Airfield Garrison 52	TSM-Comanche (FWD) 46
Aviation Support Facility Knox 60	I Corps and Fort Lewis Aviation Office 75	U.S. Army Aeronautical Services Agency 74
Avionics Branch, A/IEWS Division, USA CECOM SEC . 65	Ill Corps Aviation Office 71	U.S. Army Command Control Sys/Avionics Directorate . 65
Avn. Ground Support Equipment Weapons System Mgr., WSD, USAAMCOM 38	Integrated Materiel Mgmt Center (IMMC), USAAMCOM 40	U.S. Army Safety Center 34
Avn. Section, U.S. Army Airborne & Special Opns. Test Directorate 68	Italian Liaison Office 32	U.S. Army Dental Clinic Command, USAAVNC 34
B Company, 159th Aviation Regiment 50	Joint Warfighting Div., Require. Integ. Dir., TRADOC . . 75	U.S. Army Aeromedical Research Laboratory 34
B Company, 4-123rd Theater Aviation Reg 42	Kiowa Warrior Product Office 38	U.S. Army Air Operations Division 66
B Company, 214th Aviation Regiment 52	Land Combat Missile Directorate, (IMMC) USAAMCOM 40	U.S. Army Armor Center 60
B Co., 1-112th LUH 64	Land Combat Systems Division, WSD, USAAMCOM . . 38	U.S. Army Simulation, Training & Instrumen. Cmd.(STRICOM) 48
Biggs Army Airfield 71	Legal Office, USAAMCOM 36	U.S. Army Pacific (USARPAC), ODCSOPS Avn Div . . . 52
Branch Historian, USAAVNC 28	Logistics Support Directorate, (IMMC), USAAMCOM . 40	U.S. Army Warrant Officer Career Center 32
British Liaison Office 32	Logistics Division, OCAR 74	U.S. Army Aviation Technical Test Center (ATTC) . . . 32
Business Mgmt Office, Acquisition Ctr, USAAMCOM . . 40	Longbow Apache Product Manager's Office 36	U.S. Army School of Aviation Medicine 34
C Company, 25th Aviation Regiment (AVIM) 52	Massachusetts Army Nat'l Guard Avn Supp. Fac #2 . . 62	U.S. Army Air Ambulance Detachment 44
C Co., 1-112th LUH 64	Michigan Army National Guard Army Aviation Supp Fac 62	U.S. Army Infantry School, Aviation Division 50
C Company, 1-189th Aviation Battalion 42	Minnesota Army National Guard Army Avn Supp. Fac . 62	U.S. Army Aviation Museum 34
C Company, 123d Aviation (AVIM) 42	Missile Logistics Supp. Dir., Acquis. Center, USAAMCOM . 40	U.S. Army Garrison 66
Camp Red Cloud Sub-Post Camp Page 79	Missile Research, Develop. & Engineering Center USAAMCOM 40	U.S. Army Flight Operations Detachment 76
Camp Page Army Airfield 79	Mission Mgmt/Survival Radio Br./CCS/Avionics Dir., CECOM 65	U.S. Army Research Institute Rotary Wing Aviation Research Unit 34
Canadian Forces Liaison Office 32	Mobilization AVCRAD Control Element (MACE) 62	U.S. Military Academy Flight Detachment 66
Cargo Helicopter Project Manager's Office 36	Multi-Media Branch, Direct. of Aviation & Safety, NGB . 34	U.S. Army Aviation Logistics School (USAALS) 74
Comanche Division, Acquisition Center, USAAMCOM . 40	Multipurpose Ind. Munition/Short Range Asslt Weapon Product Ofc. 38	U.S. Army Aviation Center (USAAVNC) 28
Comanche Program Manager's Office 36	National Rotorcraft Technology Center 44	U.S. Army Reserve Personnel Center, Aviation Branch . 64
Comanche Crew Support System PM's Office 36	Netherlands Liaison Office 32	U.S. Army Aeromedical Center 34
Combat Avn Test Div., Avn Test Direct., USATEXCOM . 72	Office, PM Combined Arms Assess. Network (PM CAAN), STRICOM 48	U.S. Army Air Traffic Control Activity 30
Combat Maneuver Training Center 78	Office, Director of Army Safety 48	U.S. Army Aviation Ctr Noncommissioned Officer Academy 30
Command Aviation Flight Detachment 56	Office, ADCSOPS for Force Development 46	U.S. Army Aviation and Missile Cmd. (USAAMCOM) . 36
Competition Mgmt Office, USAAMCOM 36	Office, Directorate for Defense Research & Engineering (ODDR&E) 46	U.S. Total Army Personnel Command (PERSCOM) . . . 73
Corporate Information Center, USAAMCOM 40	Office, PM, Joint Tactical Unmanned Aerial Vehicles . . 40	Unmanned Ground Vehicle/Sys. Joint Project Office, USAAMCOM 38
Corpus Christi Army Depot (CCAD) 70	Office, Unmanned Aerial Vehicles Joint Project (UAV) . 74	US Army Test, Measurement & Diagnostic Equipment Activity, AAMCOM 38
D Company, 4-123rd Theater Avn Regiment 42	Office PM, Night Vision/RSTA 74	USAAMC-AAD (FLATIRON) 34
Danish Liaison Office 32	Operational Support Airlift Agency (OSAA) 74	USAAVNC Liaison to German Army Aviation 76
Defense Contract Mgmt Command, Boeing Philadelphia 69	Operations, Readiness & Force Develop. Div., OCAR . 48	USAG Aviation Detachment 40
Defense Contract Mgmt. Command The Boeing Co . . . 42	Operations Group, Aviation Trainer Division, NTC . . . 44	USAREUR 76
Defense Contract Mgm Command, Bell Helicopter Textron 72	PEO Aviation Directorate, Acquisition Center, USAAMCOM 40	Utility Helicopters Project Office, USAAMCOM 38
Department of Attack Helicopter Training, USAALS . . 74	PEO Tactical Missiles Directorate, Acquisition Center, USAAMCOM 40	Utility/Cargo Team, Army Aviation Div, ODCSOPS . . . 46
Department of Aviation Trades Training, USAALS . . . 75		Warrant Officer Division, OPMD, TAPC 73
Dept. of Aviation Sys Training, USAALS 74		Waynesville Regional Airport at Fomey Field 64
Deputy for Systems Acquisition, USAAMCOM 38		Weapons Systems Directorate, USAAMCOM 38
Det 1, 1085th MED 64		Western Army Nat'l Guard Avn Training Site (WAATS) . 42
Det 1, 198th Medical Company (AA) 69		
Det. B, Co C, 2-228th Avn Regt 56		

MISSION: It's as certain as gravity: the more complex your air fleet, the greater the headache of supporting it. So perhaps some streamlining is in order. A single source for any service, on any aircraft, anywhere. A single point of accountability, as utterly dependable as the laws of aerodynamics.

The three principal forces that keep an aircraft aloft: Thrust. Lift. Us.

$$F = \frac{LV}{\cosine \theta} = \frac{W}{\cosine \theta}$$
$$LH = F \text{ sine } \theta = \text{centrifugal force}$$

LOCKHEED MARTIN

SUCCESS: Announcing Lockheed Martin Aircraft and Logistics Centers. Repairs, maintenance, modifications and logistics support for everything you manage. Our own extensive facilities in the U.S. and overseas. Field service teams who go anywhere. In short, maximum lift. And zero drag. For details, call Business Development: 864-422-6241.

$\frac{W}{L}$ = Lift Factor

ALABAMA Birmingham

Alabama Army National Guard
Aviation Support Facility 2
5701 East Lake Boulevard
Birmingham, AL 35217-3599

AASFC: LTC Bennie J. Holmes
ATTN: AL-AASF-B
C: 205-841-0111; DSN: 778-2241
SIP: MAJ Barry A. DeFoor
C: 205-841-0111; DSN: 778-2241
AMO: CW4 Steve Hubbard
C: 205-841-0111; DSN: 778-2241

Fort Rucker

U.S. Army Aviation Center
(USAAVNC)
Fort Rucker, AL 36362-5000



Commanding General:
MG Anthony Jones
ATTN: ATZQ-CG,
Building 114
C: 334-255-2606
DSN: 558-2600
anthony_jones@rucker-emh4.army.mil



Deputy Commanding General:
BG Charles M. Burke
ATTN: ATZQ-DCG
C: 334-255-2612
DSN: 558-2612
charles_burke@rucker-emh4.army.mil



Deputy Assistant Commandant - National Guard:
COL Robert E. Godwin
ATTN: ATZQ-DAC-N
C: 334-255-3445
DSN: 558-3445
robert_godwin@rucker-emh4.army.mil



Chief of Staff:
COL Davis D. Tindoll
ATTN: ATZQ-CS
C: 334-255-2500
DSN: 558-2500
davis_tindoll@rucker-emh4.army.mil

Deputy Chief of Staff: MAJ Robert K. Mock
ATTN: ATZQ-SGS
C: 334-255-9026; DSN: 558-9026
rob_mock@rucker-emh4.army.mil



Commander, Garrison Support Command:
COL James L. Laughlin
ATTN: ATZQ-GC
C: 334-255-2095
DSN: 558-2095
philip_wilkerson@rucker-emh4.army.mil



Secretary of the General Staff:
Major Molly Root
ATTN: ATZQ-SGS
C: 334-255-9239
DSN: 558-9239
molly_root@rucker-emh4.army.mil



Command Sergeant Major:
CSM Edward P. Iannone
ATTN: ATZQ-CSM
C: 334-255-4800
DSN: 558-3528

Air Maneuver Battle Lab Directorate, USAAVNC
Building 5000
Corner of 3rd Ave & Lucky Star
Fort Rucker, AL 36362

Deputy Director: COL Gary S. Coleman
C: 334-255-3485; DSN: 598-3485
gary_coleman@rucker-emh4.army.mil

Aviation Branch Personnel Propensity Office (AP)
Building 4103
U.S. Army Aviation Center
Fort Rucker, AL 36362-5035



Chief:
LTC James W. Kelton
ATTN: ATZQ-AP
C: 334-255-9357
DSN: 558-9357
james_kelton@rucker-emh4.army.mil

Senior WO, AWO Personnel Propensity: CW5 Don Compton
ATTN: ATZQ-AP
C: 334-255-9357; DSN: 558-9357
donald_compton@rucker-emh4.army.mil



Senior NCO:
Master Sergeant Lisa M. Deere
ATTN: ATZQ-AP
C: 334-255-2359
DSN: 558-2359
lisa_deere@rucker-emh4.army.mil

Aviation Planning Group, USAAVNC
Building 114
Fort Rucker, AL 36362

Chief: MAJ Molly Root
ATTN: ATZQ-APG
C: 334-255-3247;
DSN: 558-3247
molly_root@rucker-emh4.army.mil

Deputy Chief: CPT Darryl Taylor
ATTN: ATZQ-APG
C: 334-255-9459; DSN: 558-9459
darryl_taylor@rucker-emh4.army.mil

Special Assistant to the CG: CPT Ken Verhulst
ATTN: ATZQ-APG
C: 334-255-3056; DSN: 558-3056
ken_verhulst@rucker-emh4.army.mil

Branch Historian, USAAVNC

Fort Rucker, AL 36362
Branch Historian: Dr. J.W. Williams
ATTN: ATZQ-MH
C: 334-255-9151; DSN: 558-9151

Directorate of Combat Developments, USAAVNC

U.S. Army Aviation Center
Fort Rucker, AL 36362-5000



Director:
COL Jesse (Mark) Danielson
ATTN: ATZQ-CD
C: 334-255-3203
DSN: 558-3203
mark_danielson@rucker-emh4.army.mil

Deputy Director: Mr. Glenn Harrison
ATTN: ATZQ-CD
C: 334-255-3203; DSN: 558-3203
glenn_harrison@rucker-emh4.army.mil

Operations Officer: CPT Christopher Speer
ATTN: ATZQ-CD
C: 334-255-9114; DSN: 558-9114
samuel_lamb@rucker-emh4.army.mil

Directorate of Community and Family Activities, USAAVNC

Fort Rucker, AL 36362
Director: Ms. Joann Blanks
ATTN: ATZQ-DCF
C: 334-255-2100; DSN: 558-2100

Directorate of Evaluation and Standardization, USAAVNC

Building 5111
U.S. Army Aviation Center
Fort Rucker, AL 36362-5000



Director:
COL James L. Mowery
ATTN: ATZQ-ES
C: 334-255-2603
DSN: 558-2603
james_mowery@rucker-emh4.army.mil

Deputy Director: MAJ Don J. Dudley
ATTN: ATZQ-ES
C: 334-255-1098; DSN: 558-1098
don_dudley@rucker-emh4.army.mil

Operations Officer: Mr. Nick Smythe
ATTN: ATZQ-ESO
C: 334-255-2244; DSN: 558-2244
nicholas_smythe@rucker-emh4.army.mil

Directorate of Human Resources, USAAVNC

U.S. Army Aviation Center
Fort Rucker, AL 36362-5000
Director: Ms. Joan Escalfullery
ATTN: ATZQ-DHR
C: 334-255-2475; DSN: 558-2475

Directorate of Information Management, USAAVNC

Building 3906
U.S. Army Aviation Center
Fort Rucker, AL 36362

Director: Mr. Floyd Leighton II
ATTN: ATZQ-DJM
C: 334-255-2174; DSN: 558-2174
Senior NCO: MSG Margaret Baldez
ATTN: ATZQ-DIM
C: 334-255-2369; DSN: 558-2369

Directorate of Logistics, USAAVNC

Fort Rucker, AL 36362-5112
Director: Mr. G. J. (Jerry) Leavis
ATTN: ATZQ-DOL
C: 334-255-2400; DSN: 558-2400
jerry_leavis@rucker-emh4.army.mil

Senior NCO: SFC John Lopez
ATTN: ATZQ-DOL
C: 334-255-2730; DSN: 558-2730

Directorate of Plans, Training, Mobilization & Security, USAAVNC

U.S. Army Aviation Center
Fort Rucker, AL 36362-5152



Acting Director:
Mr. Hugh M. Weeks
ATTN: ATZQ-DPT,
Building 114
C: 334-255-9903
DSN: 558-9903
hugh_weeks@rucker-emh4.army.mil



Senior NCO:
SGM Michael G. Whittaker
ATTN: ATZQ-DPT-SGM
C: 334-255-2710
DSN: 558-2710
michael_whittaker@rucker-emh4.army.mil

Directorate of Resource Management, USAAVNC

Building 2801
Fort Rucker, AL 36362-5143
Director: LTC David N. Pruitt
ATTN: ATZQ-R
C: 334-255-3158; DSN: 558-3158
david_pruitt@rucker-emh4.army.mil

Directorate of Training, Doctrine and Simulation, USAAVNC

Building 502
U.S. Army Aviation Center
Fort Rucker, AL 36362



Director:
COL William W. Powell
ATTN: ATZQ-TDS
C: 334-255-3320
DSN: 558-3320
william_powell@rucker-emh4.army.mil

Operations Officer: Ms. Teresa Strickland

ATTN: ATZQ-TDS-O
C: 334-255-9252; DSN: 558-9252
teresa_strickland@rucker-emh4.army.mil



Senior NCO:
SGM Joe H. Hooks
ATTN: ATZQ-TDS
C: 334-255-9205
DSN: 558-9205
joe_hooks@rucker-emh4.army.mil



Helicopter **Gun/Rocket** Systems

7.62 mm, .50 Cal, 40mm, 30mm, 2.75", Missiles



**CONTRACT
FABRICATION
& DESIGN, INC.**

5427 FM 546
Princeton, TX 75407
(972) 736-2260
FAX (972) 736-6063

CONTRACT FABRICATION
& DESIGN, INC.

- Ordnance Mounting System ("OMS/PLANK")
- LR-30 Low Recoil 30MM Cannon

GENERAL DYNAMICS
ARMAMENT SYSTEMS

- GAU-19/A .50 CAL Machine Gun

MISSILE

- AGM-114 HELLFIRE



Aviation Electronic Combat Team, USAAVNC

U.S. Army Aviation Center
Fort Rucker, AL 36362



Chief:
CW4 Stephen L. Woods
ATTN: ATZQ-TDS-GE
C: 334-255-1861
DSN: 558-1861
steve_woods@rucker-emh4.army.mil

Public Affairs Office, USAAVNC

Building 115
U.S. Army Aviation Center
Fort Rucker, AL 36362-5033

PAO: MAJ Michael Negard

ATTN: ATZQ-PAO
C: 334-255-2252;
DSN: 558-2252
michael_negard@rucker-emh4.army.mil

Deputy PAO: Mr. Ken Holder

ATTN: ATZQ-PAO
C: 334-255-2590; DSN: 334-255-1004
ken_holder@rucker-emh4.army.mil

U.S. Army Aviation Center

Noncommissioned Officer Academy

Building 4301
Fort Rucker, AL 36362-5255

Commandant: CSM Sanford C. Tanna

ATTN: ATZQ-NCA
C: 334-255-1307; DSN: 558-1307
sanford_tanna@rucker-emh4.army.mil

Assistant Commandant: SFC Miriam C. Johnson

ATTN: ATZQ-NCA
C: 334-255-3568; DSN: 558-3568
miriam_johnson@rucker-emh4.army.mil

Operations NCO: SFC Timothy L. Fleming

ATTN: ATZQ-NCA-O
C: 334-255-1311; DSN: 558-1311
timothy_fleming@rucker-emh4.army.mil

U.S. Army Air Traffic Control Activity

U.S. Army Aviation Center

Dean Street, Bldg. 3503

Fort Rucker, AL 36362-5265

Director: LTC Frank J. Stashak

C: 334-255-3007; DSN: 558-3007
frank_stashak@rucker-emh4.army.mil

Chief of Program Mgmt: Mr. Fred Hellon

C: 334-255-2780; DSN: 558-2780
fred_hellon@rucker-emh4.army.mil

TRADOC System Manager for Comanche

Building 512

U. S. Army Aviation Center

Fort Rucker, AL 36362-5010



TSM-C:
COL James A. Herberg
ATTN: ATZQ-TSM-C
C: 334-255-2160
DSN: 558-2160
james_herberg@rucker-emh4.army.mil

Technical Advisor: Mr. Mark A. Caskey

ATTN: ATZQ-TSM-C
C: 334-255-2828; DSN: 558-2828
mark_caskey@rucker-emh4.army.mil

Executive Officer: LTC Joseph W. McVeigh

ATTN: ATZQ-TSM-C
C: 334-255-2860; DSN: 558-2860
joseph_mcveigh@rucker-emh4.army.mil

Asst TSM-C (TNG): MAJ Brian P. Shoop

ATTN: ATZQ-TSM-C
C: 334-255-2857; DSN: 558-2857
brian_shoop@rucker-emh4.army.mil

Asst TSM-C (Crew Station/Wpns):

CW3 Scott McPherson
ATTN: ATZQ-TSM-C
C: 334-255-3505; DSN: 558-3505
scott_mcpherson@rucker-emh4.army.mil

Asst TSM-C (Systems Integration):

MAJ Frank Millerd
ATTN: ATZQ-TSM-C
C: 334-255-2830; DSN: 558-2830
frank_millerd@rucker-emh4.army.mil

Asst TSM-C (T800): SFC Al Luzier

ATTN: ATZQ-TSM-C
C: 334-255-2842; DSN: 558-2842
al_luzier@rucker-emh4.army.mil

Asst TSM-C Combined Test Team:

CW4 Ron Moring
ATTN: ATZQ-TSM-C
C: 561-775-5598
moringr@comanche.redstone.army.mil

Asst TSM-C Combined Test Team:

SFC Joseph Hughes
ATTN: ATZQ-TSM-C
C: 561-775-5596
hughesj@comanche.redstone.army.mil

Asst TSM-C Combined Test Team:

SFC Joseph Hughes
ATTN: ATZQ-TSM-C
C: 561-775-5596
hughesj@comanche.redstone.army.mil

TRADOC System Manager (TSM) for Longbow (LB)

U.S. Army Aviation Center

Fort Rucker, AL 36362-5012



TSM-LONGBOW:
COL Michael C. Striplin
ATTN: ATZQ-TSM-LB,
Bldg. 512
C: 334-255-2167
DSN: 558-2167
cash_striplin@rucker-emh4.army.mil

TSM-LONGBOW Technical Advisor:

Mr. Paul W. Revels
ATTN: ATZQ-TSM-LB, Bldg. 512
C: 334-255-2167; DSN: 558-2167
paul_revels@rucker-emh4.army.mil

Deputy TSM-Longbow: LTC Clay Carter

ATTN: ATZQ-TSM-LB, Bldg. 512
C: 334-255-2167; DSN: 558-2167
clay_carter@rucker-emh4.army.mil

Asst TSM-FCR/Hellfire/Armament:

CPT Josh Sauls
ATTN: ATZQ-TSM-LB, Bldg. 512
C: 334-255-2167; DSN: 558-2167
david_washington@rucker-emh4.army.mil

Asst TSM-Pers/Tng/APACHE & LONGBOW: CPT David Washington

ATTN: ATZQ-TSM-LB, Bldg. 512
C: 334-255-2167; DSN: 558-2167
david_washington@rucker-emh4.army.mil

Asst TSM-Log: SFC Robert Kriz

ATTN: ATZQ-TSM-LB, Bldg. 512
C: 334-255-2167; DSN: 558-2167
robert_kriz@rucker-emh4.army.mil

Aviation Training Brigade

Building 2805

U.S. Army Aviation Center

Fort Rucker, AL 36362-5000



Commander:
COL Robert L. Gore
ATTN: ATZQ-ATB
C: 334-255-2607
DSN: 558-2607

Deputy Commander: MAJ(P) Charles Reed

ATTN: ATZQ-ATB
C: 334-255-2607; DSN: 558-2881

SIP: Mr. Jerry Riley

ATTN: ATZQ-ATB-NS
C: 334-255-3259; DSN: 558-3259

Night Vision Branch: CW5 Jacob H. Stevens

ATTN: ATZQ-ATB-NS
C: 334-255-9545; DSN: 558-9545

ASO: CW4 Robert L. Allen

ATTN: ATZQ-ATB-S
C: 334-255-3049; DSN: 558-3049



Senior NCO:
CSM John T. Lawrence
ATTN: ATZQ-ATB
C: 334-255-3954
DSN: 558-3954

Helicopter School Battalion

Aviation Training Brigade

U.S. Army Aviation Center

Fort Rucker, AL 36362-5000



Commander:
LTC Jan P. Ithier
ATTN: ATZQ-ATB-B
C: 334-255-8524
DSN: 558-8524
ithierj@rucker-emh4.army.mil

Executive Officer: MAJ David Phares

ATTN: ATZQ-ATB-BH
C: 334-255-8525; DSN: 558-8525
cantwell@rucker-emh4.army.mil

SIP: CW3 Edmundo Miranda

ATTN: ATZQ-ATB-BS
C: 334-255-8265; DSN: 558-8265

ASO: CW3 Raymond Quinones

ATTN: ATZQ-ATB-BS
C: 334-255-8150; DSN: 558-8150
gabrielm@rucker-emh3.army.mil

Senior NCO: 1SG Pablo Arrue

ATTN: ATZQ-ATB-BH
C: 334-255-8137; DSN: 558-8137

1st Battalion, 11th Aviation Regiment

U.S. Army Aviation Center

Fort Rucker, AL 36362-5000



Commander:
LTC Reginald R. Gillis
ATTN: ATZQ-ATB-T
C: 334-255-2173
DSN: 558-2173
reginald_gillis@rucker-emh4.army.mil

Executive Officer: MAJ James R. Bullinger

ATTN: ATZQ-ATB-T
C: 334-255-2199; DSN: 558-2199
james_bullinger@rucker-emh4.army.mil

S1 Officer: CPT Michael D. Ellis

ATTN: ATZQ-ATB-TA
C: 334-255-3689; DSN: 558-3689
michael_ellis@rucker-emh4.army.mil

S2/3 Officer: CPT William D. McMickle

ATTN: ATZQ-ATB-TO
C: 334-255-2112; DSN: 558-2112
david_mcmickle@rucker-emh4.army.mil

S4 Officer: CPT Edward D. Rhinier

ATTN: ATZQ-ATB-TL
C: 334-255-9248; DSN: 558-9248
edward_rhinier@rucker-emh4.army.mil

Commander, HHD: CPT Richard Q. Carroll

ATTN: ATZQ-ATB-TD
C: 334-255-3395; DSN: 558-3395
richard_carroll@rucker-emh4.army.mil

Commander, A Co.: CPT Charlene P. Stinger

ATTN: ATZQ-ATB-TB
C: 334-255-1217; DSN: 558-1217
charlene_stinger@rucker-emh4.army.mil

Commander, B Co.: CPT Michael T. Engle

ATTN: ATZQ-ATB-TS
C: 334-255-1082; DSN: 558-1082
michael_engle@rucker-emh4.army.mil

Commander, C Co.: CPT Nicholas M. Anthony, Jr.

ATTN: ATZQ-ATB-TH
C: 334-255-3606; DSN: 558-3606
nicholas_anthony@rucker-emh4.army.mil

Senior NCO: CSM Johnny D. Hatten

ATTN: ATZQ-ATB-T
C: 334-255-2173
DSN: 558-2173
johnny_hatten@rucker-emh4.army.mil

1st Battalion, 14th Aviation Regiment

Aviation Training Brigade

U.S. Army Aviation Center

Fort Rucker, AL 36362-5225



Commander:
LTC Thomas W. Young
ATTN: ATZQ-ATB-H
C: 334-255-5712
DSN: 558-5712
thomas_young@rucker-emh4.army.mil

Executive Officer: MAJ David W. Phares

ATTN: ATZQ-ATB-H
C: 334-255-5034; DSN: 558-5034
david_phares@rucker-emh4.army.mil

BN SIP: CW5 James W. Humphreys

ATTN: ATZQ-ATB-H
C: 334-255-5043; DSN: 558-5043
james_humphreys@rucker-emh4.army.mil

ASO: CW3 Eliseo G. Hernandez, Jr.

ATTN: ATZQ-ATB-H
C: 334-255-5042; DSN: 558-5042
eliseo_hernandez@rucker-emh4.army.mil

Ready to go with Parker Aerospace Customer Support

The world's military services
must be ready to go at all times.
In peace or conflict.

Parker Aerospace

Customer Support

Military is a specialized
organization dedicated

to the unique
needs of the
military users

of Parker Aerospace
systems and components.

We're here to help our
customers maximize their
operational readiness
while minimizing
support costs.

Global support.

Whether for
proven systems
or leading-edge aircraft,
our worldwide network of
facilities and representatives
assures you of precision service.
And our global capability enables
Parker Customer Support Military
to customize services to meet your
exact requirements.

Ready for you. Contact
Parker Customer Support Military.
For service that's as ready
as the customers we serve.

Partners in Flight™

Fuel Systems – Fuel handling equipment, including pumps, valves, and refuel/defuel subsystems • Fuel measurement and management systems • Engine fuel control and monitoring • Pressure fuelling • Instrumentation • Electronic controllers • Injection nozzles • Augmenters • Global customer support

Hydraulic Systems – Thrust reverser actuation systems • Heat exchangers • Accumulators • Steering systems • Engine-driven pumps • Lubrication and scavenge pumps • Reservoirs • Engine control actuators • Electrohydraulic servovalves • Lubrication systems • Motor-driven pumps • Hydraulic valves • Wheels and brakes • Global customer support

Flight Control Systems – Hydromechanical actuation systems and components • Power-by-wire systems and components • Smart actuation systems and components • Fly-by-wire actuation systems and components • Electrohydraulic servovalves • Electronic control modules • Electrohydrostatic actuation, controllers, and power electronics • Global customer support

Parker Hannifin Corporation

Parker Aerospace • Customer Support Military
16666 Von Karman Avenue, Irvine, CA 92606
(949) 660-8400 • Technical fax hotline: (949) 660-8444 • AOG: (949) 851-4357
<http://www.parker.com> • email: esm@parker-h.com

Parker
Aerospace



Senior NCO:
SGM James E. Jones
ATTN: ATZQ-ATB-H
C: 334-255-5076
DSN: 558-5076
james_jones@rucker-
emh4.army.mil

**1st Battalion, 212th Aviation
Regiment
Aviation Training Brigade**
Fort Rucker, AL 36362-5000



Commander:
LTC Steven P. Semmens
ATTN: ATZQ-ATB-L
C: 334-255-4111
DSN: 558-4111
steven_semmens@
rucker-emh4.army.mil

Executive Officer: MAJ Mark R. Pedron
ATTN: ATZQ-ATB-L
C: 334-255-4116; DSN: 558-4116
mark_pedron@rucker-emh4.army.mil

SIP: CW4 Geoffrey Schwind
ATTN: ATZQ-ATB-L
C: 334-255-4197; DSN: 558-4197
geoffrey_schwind@rucker-emh4.army.mil

ASO: CW4 Richard Case
ATTN: ATZQ-ATB-LS
C: 334-255-4372; DSN: 558-4372
richard_case@rucker-emh4.army.mil

Senior NCO: SGM Billy Simmons
ATTN: ATZQ-ATB-L
C: 334-255-4116; DSN: 558-4116
billy_simmons@rucker-emh4.army.mil

**1st Battalion, 223rd Aviation
Training Brigade**
U.S. Army Aviation Center
Fort Rucker, AL 36362-5230



Commander:
LTC Gasper Gulotta
ATTN: ATZQ-ATB-C
C: 334-255-8478
DSN: 558-8478
gasper_gulotta@
rucker-emh4.army.mil

Executive Officer: MAJ Robert J. Szempruch
ATTN: ATZQ-ATB-C
C: 334-255-8419; DSN: 558-8419
robert_szempruch@rucker-emh4.army.mil

SIP: CW5 James E. Manley
ATTN: ATZQ-ATB-CO
C: 334-255-8441; DSN: 558-8441
james_manley@rucker-emh4.army.mil

ASO: CW3 Keith Genter
ATTN: ATZQ-ATB-CO
C: 334-255-8490; DSN: 558-8490
keith_genter@rucker-emh4.army.mil

MTFE: CPT David E. Salter
ATTN: ATZQ-ATB-CA
C: 334-255-6347; DSN: 558-6347
david_salter@rucker-emh4.army.mil



Senior NCO:
SGM Larry B. Brey
ATTN: ATZQ-ATB-C
C: 334-255-8369
DSN: 558-8369
larry_brey@rucker-
emh4.army.mil

1st Aviation Brigade (Air Assault)
U.S. Army Aviation Center
Fort Rucker, AL 36362



Commander:
COL Grattton O.
Sealock, II
ATTN: ATZQ-BDE
C: 334-255-9083
DSN: 558-9083
neal_sealock@ruck-
er-emh4.army.mil

Deputy Brigade Commander: LTC
Theresa Barton
ATTN: ATZQ-BDE
C: 334-255-9117; DSN: 558-9117
Theresa_Barton@rucker-emh4.army.mil



Senior NCO:
CSM Sanford C. Tanna
ATTN: ATZQ-BDE
C: 334-255-3982
DSN: 558-3982
sanford_tanna@ruck-
er-emh4.army.mil

**1st Battalion, 13th Aviation Regiment
1st Aviation Brigade (AA)**
U.S. Army Aviation Center
Fort Rucker, AL 36362

Commander: LTC John S. Arnold
ATTN: ATZQ-BDE-E
C: 334-255-1314; DSN: 558-1314
John_Arnold@rucker-emh4.army.mil

Executive Officer: MAJ John McHugh
ATTN: ATZQ-BDE-E
C: 334-255-1315; DSN: 558-1315
john_mchugh@rucker-emh4.army.mil

S-1 Officer: 1LT Richard Hadnagy
ATTN: ATZQ-BDE-E
C: 334-255-1318; DSN: 558-1318
richard_hadnagy@rucker-emh4.army.mil

S-2/3 Officer: MAJ Edward Williams
ATTN: ATZQ-BDE-E
C: 334-255-1319; DSN: 558-1319
edward_williams@rucker-emh4.army.mil

S-4 Officer: SFC Roy Crawley
ATTN: ATZQ-BDE-E
C: 334-255-1340; DSN: 558-1340
roy_crawley@rucker-emh4.army.mil

Commander, HHC: CPT Jason Turner
ATTN: ATZQ-BDE-EH
C: 334-255-2454; DSN: 558-2454
jason_turner@rucker-emh4.army.mil

Commander, A Company: CPT
Lawrence Micklus
ATTN: ATZQ-BDE-EA
C: 334-255-1266; DSN: 558-1266
lawrence_micklus@rucker-emh4.
army.mil

Commander, B Company: CPT
James Rouse
ATTN: ATZQ-BDE-EB
C: 334-255-1278; DSN: 558-1278
james_rouse@rucker-emh4.army.mil

Commander, C Company: CPT
Mathew Nuhse
ATTN: ATZQ-BDE-EC
C: 334-255-1354; DSN: 558-1354
mathew_nuhse@rucker-emh4.
army.mil

Commander, D Company: CPT Dan
Soucek
ATTN: ATZQ-BDE-ED
C: 334-255-2391; DSN: 558-2391
dan-soucek@rucker-emh4.army.mil



Senior NCO:
CSM Ossie Carey
ATTN: ATZQ-BDE-E
C: 334-255-1317
DSN: 558-1317
ossie_carey@
rucker-emh4.army.mil

**1st Battalion, 145th Aviation
Regiment**

1st Aviation Brigade (AA)
U.S. Army Aviation Center
Fort Rucker, AL 36362

Commander: LTC Wade B. Becnel
ATTN: ATZQ-BDE-O
C: 334-255-2338; DSN: 558-2338
wade_becnel@rucker-emh4.army.mil

Executive Officer: MAJ James
Chapman
ATTN: ATZQ-BDE-O
C: 334-255-3787; DSN: 558-3787
james_chapman@rucker-emh4.
army.mil

ASO: CW3 Quincy R. Kelly
ATTN: ATZQ-BDE-OB
C: 334-255-9395; DSN: 558-9395
quincy_kelly@rucker-emh4.army.mil

Senior NCO: 1SG Anthony C. Brown
ATTN: ATZQ-BDE-O
C: 334-255-2039; DSN: 558-2039
anthony_brown@rucker-emh4.
army.mil

**1st Battalion, 210th Aviation
Regiment**

1st Aviation Brigade (AASLT)
U.S. Army Aviation Center
Fort Rucker, AL 36362-5072

Commander: LTC Steven Moore
ATTN: ATZQ-BDE-A
C: 334-255-9134; DSN: 558-9134

Executive Officer: MAJ Dawn Eisert
ATTN: ATZQ-BDE-A
C: 334-255-1073; DSN: 558-1073

Senior NCO: CSM Ronald W. Bedford
ATTN: ATZQ-BDE-A
C: 334-255-3294; DSN: 558-3294

Australian Liaison Office

Building 107, 5th Avenue
Fort Rucker, AL 36362
Australian Liaison Officer: LTC
Anthony Peter Fraser
ATTN: ATZQ-DAC-LN
C: 334-255-3715; DSN: 558-3715
anthony_fraser@rucker-emh4.army.mil

British Liaison Office

U.S. Army Aviation Center
Fort Rucker, AL 36362
British Liaison Officer: LTC John
Greenhalgh
ATTN: ATZQ-DAC-LN, Bldg 107
C: 334-255-3715; DSN: 558-3715
john_greenhalgh@rucker-emh4.army.mil

Canadian Forces Liaison Office

U.S. Army Aviation Center
Bldg. 107, 5th Avenue
Fort Rucker, AL 36362-5000
Canadian Forces Liaison Officer
Aviation: MAJ Robert F. Bayes
C: 334-255-3715; DSN: 558-3715
robert_bayes@rucker-emh4.army.mil

Danish Liaison Office

5 Avenue, Bldg. 107
U.S. Army Aviation Center
Fort Rucker, AL 36362
National Liaison Officer Denmark:
MAJ Per E. Christiansen
C: 334-255-2556; DSN: 558-2556
per_christiansen @rucker-M573

French Liaison Office
U.S. Army Aviation Center
Fort Rucker, AL 36362



**French Liaison
Officer:**
LTC Marc Demier
ATTN: ATZQ-DAC-LN,
Bldg 107
C: 334-255-3052
DSN: 558-3052
marc_demier@rucker-
emh4.army.mil

German Army Liaison Staff USA 5
P. O. Box 820579, Bldg. 107
Fort Rucker, AL 36362-0579

German Liaison Officer: LTC Heinrich
Bierbrauer
ATTN: ATZQ-DAC-LN, Bldg 107
C: 334-255-9129; DSN: 558-9129
heinrich_bierbrauer@rucker-emh4.
army.mil

Italian Liaison Office

U.S. Army Aviation Center
Bldg. 107, 5th Avenue
Fort Rucker, AL 36362-5000
Italian Liaison Officer: LTC Erminio
Pierangelini
ATTN: ATZQ-DAC-LN
C: 334-255-9235; DSN: 558-9235
antonio_dimiele@rucker-emh4.army.mil

Netherlands Liaison Office

U.S. Army Aviation Center
Fort Rucker, AL 36362
**Liaison Officer, Royal Netherlands
Air Force:** LTC Geert Zijlsta
ATTN: ATZQ-CS-LN, Bldg. 107
C: 334-255-3171; DSN: 558-3171
geert_zijlsta@rucker-emh4.army.mil

**U.S. Army Warrant Officer Career
Center**

Fort Rucker, AL 36362
Commandant: COL Richard M. Johnson
ATTN: ATZQ-WCC
C: 334-255-3869; DSN: 558-3869
richard_johnson@rucker-emh4.army.mil

Aviation Office, USATECOM

Bldg. 30601, Cairns AAF
Fort Rucker, AL 36362-5276



**Aviation Staff
Officer:**
COL Austin R. Omilea
ATTN: STEAT-CO
C: 334-255-8000
DSN: 558-8000
omilea@rucker-
attc.army.mil

**U.S. Army Aviation Technical Test
Center (ATTC)**

Fort Rucker, AL 36362-5276
Commander:
COL Austin R. Omilea
ATTN: STEAT-CO
C: 334-255-8000
DSN: 558-8000
omilea@rucker-attc.army.mil
Technical Director: Mr. Larry E.
Eagerton
ATTN: STEAT-CO-T
C: 334-255-8001; DSN: 558-8001
eagertol@rucker-attc.army.mil



**THE U.S. ARMY
REQUIRED IT.**

**ACME AEROSPACE
SUPPLIED IT.**

**CHOSEN AS THE OEM FOR THE BATTERY AND
CHARGER SYSTEM ON THE AH-64D APACHE LONGBOW.
BATTERY AND CHARGER SYSTEM ALSO AVAILABLE FOR AH-64A APACHE.**

*By selecting the sealed
Fiber Nickel-Cadmium
(FNC) battery system,
the U.S. Army realized
a 3% improvement in
RAM over the AH-64A.*

*Considering the size and
complexity of the Apache
Longbow, this is a
major accomplishment.*

Zero-Maintenance

SEALED FNC BATTERIES

Superior Performance

BATTERY CONTROL UNITS/CHARGERS

Lower Life Cycle Cost

AC/DC AND DC/DC CONVERTERS

High Reliability

AMPS BACKUP POWER SUPPLIES

Long Life

INTEGRATED POWER SYSTEMS



**Acme Electric
Corporation**

Aerospace Division • 528 W. 21st Street • Tempe, AZ 85282
Phone 602/894-6864 • Fax 602/921-0470

Adjutant/HQ Company Commander:

Mr. George D. Stinson
ATTN: STEAT-AD/HC
C: 334-255-8002; DSN: 558-8002
steatad@rucker-attc.army.mil

Safety Officer: CW5 Jimmie G. Pernell

ATTN: STEAT-SA
C: 334-255-8037; DSN: 558-8037
pernellj@rucker-attc.army.mil

Flight Systems Test Directorate: LTC

Henry H. Waller
ATTN: STEAT-FT
C: 334-255-8149; DSN: 558-8149
steatft@rucker-attc.army.mil

Test Support Directorate: Mr. Roy L.

Miller
ATTN: STEAT-TS
C: 334-255-8087; DSN: 558-8087
steatts@rucker-attc.army.mil

Data Systems Directorate: Mr. Mike J.

Hamilton
ATTN: STEAT-DS
C: 334-255-8092; DSN: 558-8092
steatds@rucker-attc.army.mil

**Senior NCO:**

SSG Michael Tucker
ATTN: STEAT-HC
C: 334-255-8599
DSN: 558-8599
tuckerm@rucker-attc.army.mil

Flight Test Directorate, U.S. Army

Aviation Technical Test Center
Fort Rucker, AL 36362-5276

**Commander:**

LTC Henry H. Waller III
ATTN: STEAT-FT
C: 334-255-8149
DSN: 558-8149
wallerh@rucker-attc.army.mil

Chief Engineer: Mr. Courtland Bivens

ATTN: STEAT-FT
C: 334-255-8593; DSN: 558-8593
bivenscl@rucker-attc.army.mil

Chief of Flight Test: LTC Steven

Walters
ATTN: STEAT-FT
C: 334-255-8116; DSN: 558-8116
walterss@rucker-attc.army.mil

Test Evaluation Coordination Office

(TECO), OPTEC

Building 30604
Cairns Army Airfield

Fort Rucker, AL 36362-5064

Chief: LTC Keith E. Gay

ATTN: CSTE-COR
C: 334-255-8416; DSN: 558-8416

Deputy: Mr. Danny G. Curry

ATTN: CSTE-COR
C: 334-255-8423; DSN: 558-8423

RDT&E NCO: SSG Edward P. Antonio

ATTN: CSTE-COR
C: 334-255-8423; DSN: 558-8423

U.S. Army Research Institute Rotary

Wing Aviation Research Unit

Building 5100

Fort Rucker, AL 36362-5354

Chief: Dr. Dennis C. Wightman

ATTN: TAPC-ARI-IR
C: 334-255-2834; DSN: 558-2834
wightman@rwaru-emh1.army.mil

Multi-Media Branch, Directorate of

Aviation & Safety, NGB

P. O. Box 620249

Fort Rucker, AL 36362-0249

Chief, Multi-Media Branch: MAJ T.

Cowart
ATTN: NGB-AVN-MMB
C: 334-255-2520; DSN: 558-2520
t_cowart@rucker-emh4.army.mil

U.S. Army Aeromedical Center

Building 301

U.S. Army Aviation Center

Fort Rucker, AL 36362-5333

**Commander:**

COL Gary N. Matteson
ATTN: MCXY-C
C: 334-255-7359
DSN: 558-7359
col_gary_n_matteson@rucker.smtplink.amedd.army.mil

Deputy Commander for Clinical

Services: LTC Walter J. Hubickey

ATTN: MCXY-DCCS

C: 334-255-7343; DSN: 558-7343

lfc_walter_hubickey@rucker,

smtplink.amedd.army.mil

Deputy Commander for

Administration: LTC Donald E.

Henderson, Jr.

ATTN: MCXY-DCA

C: 334-255-7361; DSN: 558-7361

lfc_donald_henderson@rucker.smtplink.amedd.army.mil

USAAMC-AAD (FLATIRON)

Fort Rucker, AL 36362-5350

Commander: CPT Stephen G. Suttles

ATTN: HSXY-AAD

C: 334-255-8427; DSN: 558-8543

cpt_stephen_suttles@smtplink.

rucker.amedd.army.mil

U.S. Army School of Aviation

Medicine

Fort Rucker, AL 36362-5377

Dean: COL James S. McGhee, Jr.

ATTN: MCCA-HA

C: 334-255-7409; DSN: 558-7409

Assistant Dean: LTC Timothy D.

Toomey

ATTN: MCCA-HA

C: 334-255-7416; DSN: 558-7416

lfc_timothy_toomey@smtplink.

rucker.amedd.army.mil

Senior NCO: 1SG Lee A. Harrington

ATTN: MCCA-HA

C: 334-255-7417; DSN: 558-7417

1sg_lee_harrington@smtplink.

rucker.amedd.army.mil

U.S. Army Dental Clinic Command,

USAAVNC

Fort Rucker, AL 36362-5350

Commander: COL Joseph A. Britton

ATTN: MCDS-SEBR-A

C: 334-255-1155; DSN: 558-1155

Chief Dental NCO/1SG: SFC Tyrone

S. Leonard

ATTN: MCDS-SEBR-A

C: 334-255-9285; DSN: 558-9285

U.S. Army Aeromedical Research

Laboratory

Building 6901

P. O. Box 620577

Fort Rucker, AL 36362-0577

**Commander:**

COL Cherry L. Gaffney

ATTN: MCMR-UAC

C: 334-255-6917

DSN: 558-6917

cherry_gaffney@

usaarl-ccmail.army.mil

Deputy Commander for

Administration: COL Rodger R.

Sexton

ATTN: MCMR-UAC-D

C: 334-255-6914; DSN: 558-6914

col_randy_sexton@usaarl-ccmail.

army.mil

U.S. Army Safety Center

Building 4905

1209 5th Avenue

Fort Rucker, AL 36362

Commander: BG Burt S. Tackaberry

ATTN: CSSC-Z

C: 334-255-9360; DSN: 558-9360

tackabeb@safety-emh1.army.mil

Deputy Commander: COL John S.

Warren

ATTN: CSSC-Z

C: 334-255-3075; DSN: 558-3075

warrenj@safety-emh1.army.mil

Senior NCO: Master Sergeant Peggy

A. Adams

ATTN: CSSC-Z

C: 334-255-3575; DSN: 558-3575

adamp@safety-emh1.army.mil

U.S. Army Aviation Museum

U.S. Army Aviation Center

P.O. Box 620610

Fort Rucker, AL 36362-0610

Director: Mr. R. S. Maxham

ATTN: ATZQ-DPT-M

C: 334-255-3036; DSN: 558-3036

Hope Hull**Alabama Army National Guard**

Aviation Support Facility 1

P.O. Box 309

Hope Hull, AL 36043

AASFC: LTC Joseph A. Price

C: 334-281-7722; DSN: 358-9237

Mobile**Alabama Army National Guard Army**

Aviation Support Facility #3

Bates Field

9055 Tanner Williams Rd.

Mobile, AL 36608

AASFC: MAJ Charles E. Bonasera

ATTN: AL-AASF#3

C: 334-634-8773

aasf3al@al-ngnet.army.mil

Montgomery**Office, State Adjutant General,**

Alabama Army National Guard

P. O. Box 3711

Montgomery, AL 36109-0711

**TAG:**

MG Clyde A. Hennies

C: 334-271-7200

DSN: 363-7200

hennies@al-ngnet.

army.mil

Office, State Army Aviation Officer,

Alabama Army National Guard

P. O. Box 3711

Montgomery, AL 36193-4701

SAAO: LTC Billy G. Kennedy

ATTN: AL-SAAO

C: 334-271-7263; DSN: 363-7263

soaal@al-ngnet.army.mil

Redstone Arsenal**Program Executive Office, Aviation**

Building 5681

Redstone Arsenal, AL 35898-5000

**PEO, Aviation:**

MG James R. Snider

ATTN: SFAE-AV

C: 256-313-4000

DSN: 897-4000

sniderj@peoavn.red-

stone.army.mil

Deputy PEO: Mr. Paul Bogosian

ATTN: SFAE-AV

C: 256-313-4001; DSN: 897-4001

bogosianp@peoavn.redstone.army.mil

Director of Business Management:

Mr. Charles G. Buttrey, Jr.

ATTN: SFAE-AV-P

C: 256-313-4007; DSN: 897-4007

buttreyg@peoavn.redstone.army.mil

Director of Concurrent Engineering:

Mr. Ronald E. Gormont

ATTN: SFAE-AV-P

C: 256-313-4134; DSN: 897-4134

gormontr@peoavn.army.mil

Assistant PEO Horizontal

Technology Integration: LTC(P) Gary

D. Jerauld

ATTN: SFAE-AV

C: 256-313-4009; DSN: 897-4009

Aircrew Integrated Systems Project

Manager's Office

Building 5681

Redstone Arsenal, AL 35898-5000

Project Manager: Mr. Thomas R.

Metzler

ATTN: SFAE-AV-LSE

C: 256-313-4300; DSN: 897-4300

metzliert@peoavn.redstone.army.mil

VERIDIAN

Partners With Army Aviation Through the Next Millennium



RAIL...

An Old Partner With a New Name

Introducing Veridian, an information solutions company built on more than 50 years of technology experience. Our capabilities include:

- Systems & Software Engineering
- Test & Evaluation
- Modeling & Simulation
- Information Systems
- Human Factors Engineering

We're proud to be a member of Team Comanche and look forward to continuing our commitment to the Army Aviation warfighters through the next century.

Join a growing team of leaders committed to customer service and to setting the standard of performance in our industry. To find out more about us and our more than 125 information technology and engineering positions available, visit our web site at:

www.veridian.com

An Equal Opportunity/Affirmative Action Employer

***Together With the Joint Warfighter
We're Making a Difference In Global Security***

Systems Integration Division: Mr. Jerry L. Cox

ATTN: SFAE-AV-LSE
C: 256-313-4260; DSN: 897-4260
coxj@peoavn.redstone.army.mil

Business Management Division: Mr. Edward J. Wissel

ATTN: SFAE-AV-LSE
C: 203-313-4256; DSN: 897-4250
wissele@peoavn.redstone.army.mil

Apache Attack Helicopter Project Manager's Office

Building 5681
Redstone Arsenal, AL 35898-5000



Project Manager:
COL Howard T. Bramblett
ATTN: SFAE-AV-AAH
C: 256-313-4200
DSN: 897-4200

Deputy Project Manager: Mr. Gary S. Nenninger

ATTN: SFAE-AV-AAH
C: 256-313-4200; DSN: 897-4200

Fire Control Radar Product Manager's Office

Building 5681
Redstone Arsenal, AL 35898-5000



Product Manager:
LTC John D. Burke
ATTN: SFAE-AV-AAH-FCR
C: 256-313-4310
DSN: 897-4310

Longbow Apache Product Manager's Office

Building 5681
Redstone Arsenal, AL 35898-5000



Product Manager:
LTC Ralph Palotta
ATTN: SFAE-AV-AAH-LBA
C: 256-313-4247; DSN: 897-4247

Apache Modernization Product Management Office

Building 5681
Redstone Arsenal, AL 35898-5000



Product Manager:
LTC Donald C. Huff
ATTN: SFAE-AV-AAH-ATH
C: 256-313-4248
DSN: 897-4248
huffd@peoavn.redstone.army.mil

Aviation Electronic Combat Project Manager's Office

Bldg 5681, ATTN: SFAE-AV-AEC
Redstone Arsenal, AL 35898-5000

Project Manager: Mr. Larry Johnston
ATTN: SFAE-AV-AEC
C: 256-313-4100; DSN: 897-4100
johnstonl@peoavn.redstone.army.mil

Deputy Project Manager: LTC Larry Carpenter

ATTN: SFAE-AV-AEC
C: 256-313-4101; DSN: 897-4101
carpenterl@peoavn.redstone.army.mil

Product Manager - Avionics: LTC Corwyn Trede

ATTN: SFAE-AV-AEC
C: 256-313-4424; DSN: 897-4424
tredec@peoavn.redstone.army.mil

Product Manager - ASE: Carlyn Frazier

ATTN: SFAE-AV-AEC
C: 256-313-4425; DSN: 897-4425
frazierc@peoavn.redstone.army.mil

Project Manager - ATIRCM: Dr. Steven Messervy

ATTN: SFAE-AV-AEC
C: 256-313-4498; DSN: 897-4498
messervys@peoavn.redstone.army.mil

AMPS/IDM: MAJ Tom Hood

ATTN: SFAE-AV-AEC
C: 256-313-4393; DSN: 897-4393
hoodt@peoavn.redstone.army.mil

A2C2S: MAJ Patrick Burden

ATTN: SFAE-AV-AEC
C: 256-313-4389; DSN: 897-4389
burdenp@peoavn.redstone.army.mil

High Frequency & Have Quick: MAJ Jeff Crabb

ATTN: SFAE-AV-AEC
C: 256-313-4404; DSN: 897-4404
crabbj@peoavn.redstone.army.mil

GPC: MAJ(P) Vince Tobin

ATTN: SFAE-AV-AEC
C: 256-313-4397; DSN: 897-4397
tobinv@peoavn.redstone.army.mil

SIRFC: MAJ Bob Schulz

ATTN: SFAE-AV-AEC
C: 256-313-4446; DSN: 897-4446
schulzb@peoavn.redstone.army.mil

Chief, Technical Management

Division: Mr. Jack Van Kirk
ATTN: SFAE-AV-AEC
C: 256-313-4422; DSN: 897-4422
vankirkj@peoavn.redstone.army.mil

Chief, Logistics Management

Division: Mr. Jon Evans
ATTN: SFAE-AV-AEC
C: 256-313-4499; DSN: 897-4499
evansj@peoavn.redstone.army.mil

Chief, Business Management

Division: Mr. Chuck Lines
ATTN: SFAE-AV-AEC
C: 256-313-4500; DSN: 897-4500
linesc@peoavn.redstone.army.mil

EWO: CW3 Greg Dorough

ATTN: SFAE-AV-AEC
C: 256-313-4451; DSN: 897-4451
doroughg@peoavn.redstone.army.mil

Comanche Program Manager's Office

Building 5681
Redstone Arsenal, AL 35898-5000



Program Manager:
BG Joseph L. Bergantz
ATTN: SFAE-AV-RAH
C: 256-313-0846
DSN: 897-0846
bergantzj@comanche.redstone.army.mil

Deputy Program Manager: Mr. Darrell Harrison

ATTN: SFAE-AV-RAH
C: 256-313-0841; DSN: 897-0841
harrisond@comanche.redstone.army.mil

Comanche Crew Support System Product Manager's Office

Building 5300
Redstone Arsenal, AL 35898-5000
Product Manager: LTC Deborah J. Chase
ATTN: SFAE-AV-RAH
C: 256-313-4560; DSN: 897-4560
chased@comanche.redstone.army.mil

T800 Product Manager's Office

Building 5300
Redstone Arsenal, AL 35898-5000
Product Manager: Mr. Jimmy Hill
ATTN: SFAE-AV-RAH
C: 256-213-4561; DSN: 897-4561

Cargo Helicopter Project Manager's Office

Building 5300
Project Manager: Mr. James Caudle
ATTN: SFAE-AV
C: 256-313-4302; DSN: 897-4302

Air-to-Ground Missile Systems Project Office

Redstone Arsenal, AL 35898-5610



Project Manager:
COL Richard T. Savage
ATTN: SFAE-MSL-HD
C: 256-876-1365
DSN: 746-1365
savage-rt@redstone.army.mil

Deputy Project Manager: Mr. Rhett D. Farrior

ATTN: SFAE-MSL-HD
C: 256-876-1117; DSN: 746-1117
rfarrior@redstone.army.mil

Chief, Program Management

Division: Mr. Robert Masucci
ATTN: SFAE-MSL-HD-M
C: 256-876-1271; DSN: 746-1271
rmasucci@redstone.army.mil

Chief, Technical Management

Division: Mr. Wayne Burke
ATTN: SFAE-MSL-HD-E
C: 256-876-8413; DSN: 746-8413
wburke@redstone.army.mil

APM for Product Assurance/Test/

Configuration Mgt.: Mr. James Bell, Jr.
ATTN: SFAE-MSL-HD-T
C: 256-876-3261; DSN: 746-3261
jbell@redstone.army.mil

Chief, Logistics Management

Division: Mr. Michael E. McGee
ATTN: SFAE-MSL-HD-S
C: 256-876-4187; DSN: 746-4187
mmcgee@redstone.army.mil

APM, HELLFIRE Applications: LTC Paul D. Gilley, Jr.

ATTN: SFAE-MSL-HD-L
C: 256-876-7076; DSN: 746-7076
gilley-pd@redstone.army.mil

Air-to-Ground Missile Systems Integration Office

Redstone Arsenal, AL 35898-5000

U.S. Army Aviation and Missile Command (USAAMCOM)

Sparkman Complex, Bldg. 5300
Redstone Arsenal, AL 35898-5000



Commanding General:
MG Emmitt E. Gibson
ATTN: AMSAM-CG
C: 256-876-2101
DSN: 746-2101
gibson-ee@redstone.army.mil



Deputy to the Commanding General:
Mr. Daniel J. Rubery
ATTN: AMSAM-DSB
C: 256-842-9888
DSN: 788-9888
rubery-dj@redstone.army.mil



Chief of Staff:
COL Clifton J. Broderick
ATTN: AMSAM-CS
C: 256-876-1120
DSN: 746-1120
broderick-cj@redstone.army.mil



Command Sergeant Major:
CSM Benjamin F. Sunday
ATTN: AMSAM-CSM
C: 256-876-1874
DSN: 746-1874
sunday-bf@redstone.army.mil

Secretary of the General Staff: Ms. Linda B. Readus

ATTN: AMSAM-GS
C: 256-876-3131; DSN: 746-3131
readus-lb@redstone.army.mil

Ombudsman: Mr. John W. Finafrock

ATTN: AMSAM-OB
C: 256-876-6659; DSN: 746-6659
finafrock-jw@redstone.army.mil

Competition Management Office, USAAMCOM

Bldg. 4488
Redstone Arsenal, AL 35898-5000

Competition Advocate: Mr. Wade Griffin, Jr.

ATTN: AMSAM-CM
C: 256-876-9699; DSN: 746-9699
griffin-wa@redstone.army.mil

Legal Office, USAAMCOM

Bldg. 5300
Redstone Arsenal, AL 35898-5000

Chief: Mr. Robert J. Spazzarini
ATTN: AMSAM-L
C: 256-876-3405; DSN: 746-3405
spazzarini-rj@redstone.army.mil

Public Affairs Office, USAAMCOM

Bldg. 5300
Redstone Arsenal, AL 35898-5000

PAO: Mr. Alvin M. Schwartz
ATTN: AMSAM-PA
C: 256-876-4161; DSN: 746-4161
schwartz-am@redstone.army.mil

LIFE GUARD, 2000 A.D.

WWW.SIKORSKY.COM/UH-60

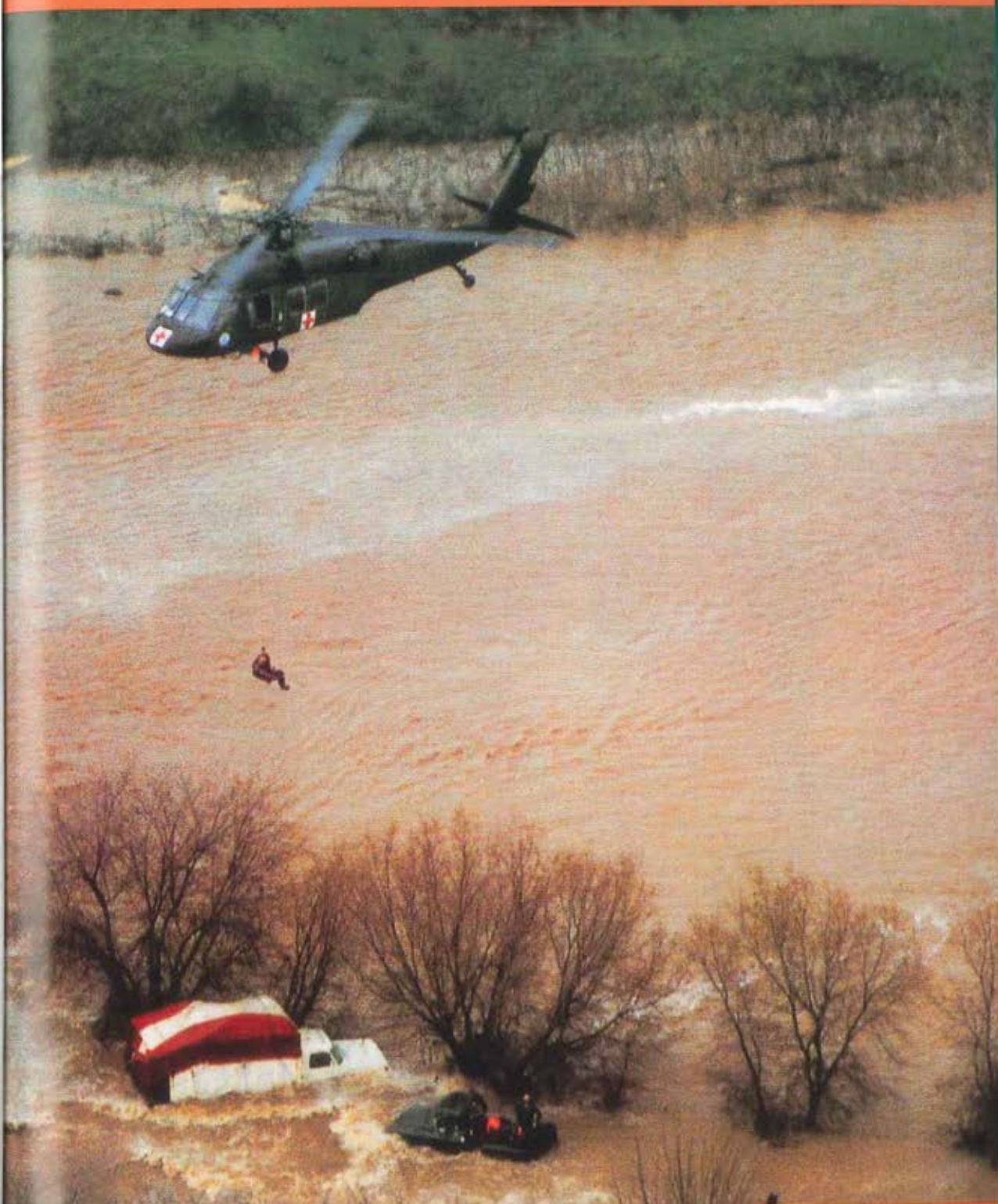

THE FASTEST WAY TO THE
FUTURE OF VERTICAL FLIGHT.



Sikorsky

A United Technologies Company

Deputy PAO: Mr. Robert E. Hunt
ATTN: AMSAM-PA
C: 256-955-9174; DSN: 645-9174
hunt-re@redstone.army.mil

Small & Disadvantaged Business Utilization Office, USAAMCOM
Bldg. 4488
Redstone Arsenal, AL 35898-5000
Chief: Mr. John F. Nelson
ATTN: AMSAM-SB
C: 256-876-5441; DSN: 746-5441
nelson-sb@redstone.army.mil

Deputy for Systems Acquisition, USAAMCOM
Sparkman Complex, Bldg. 5308
Redstone Arsenal, AL 35898-5000



Deputy for Systems Acquisition:
BG Robert E. Armbruster
ATTN: AMSAM-DSA
C: 256-955-6701
DSN: 645-6701
armbruster-re@redstone.army.mil

Air Traffic Control (ATC) Product Office, USAAMCOM
Building 5308
Sparkman Complex
Redstone Arsenal, AL 35898-5000



Product Manager:
LTC Joseph A. Durso
ATTN: AMSAM-DSA-ATC
C: 256-955-9008
DSN: 645-9008
durso-ja@redstone.army.mil

Enhanced Fiber Optic Guided Missile Project Office, USAAMCOM
Redstone Arsenal, AL 35898-5000



Director:
LTC James (Tom) Harvill, Jr.
ATTN: AMSAM-DSA-EFW
C: 256-876-7725
DSN: 746-7725
Tom Harvill@teamefogm.redstone.army.mil

Fixed Wing Product Office, USAAMCOM
Redstone Arsenal, AL 35898-5000



Product Manager:
LTC William G. Lake, Jr.
ATTN: AMSAM-DSA-FW
C: 256-955-0081
DSN: 645-9008
lake-wg@redstone.army.mil

Kiowa Warrior Product Office
Bldg. 5308
Redstone Arsenal, AL 35898-5000



Product Manager:
LTC James E. Weger
ATTN: AMSAM-DSA-ASH
C: 256-955-7004
DSN: 645-7004
weger-je@redstone.army.mil

Multipurpose Ind. Munition/Short Range Asslt Weapon Product Ofc.
Redstone Arsenal, AL 35898-5000



Director:
LTC Charles A. Jones, Jr.
ATTN: AMSAM-DSA-MP
C: 256-876-4799;
DSN: 746-4799
jones-CHA@redstone.army.mil

Scout/Attack Product Office, USAAMCOM

Redstone Arsenal, AL 35898-5000

Product Manager: LTC James E. Weger

ATTN: AMSAM-DSA-CO
C: 256-955-0989; DSN: 645-0989
weger-je@redstone.army.mil

Technical/Business Management

Division: Mr. John Guenther

ATTN: AMSAM-DS-CO-T

Logistics Management Division: Mr. Dave Nelson

ATTN: AMSAM-DSA-CO
C: 256-876-2528; DSN: 788-2528
nelson_d@redstone.army.mil

Smart Weapons Management Office, USAAMCOM

Redstone Arsenal, AL 35898-5000



Director:
COL Henry C. Keebler III
ATTN: AMSAM-DSA-SW
C: 256-876-5360
DSN: 746-5360
keebler-sw@redstone.army.mil

Stinger (SHORAD) Product Office
Redstone Arsenal, AL 35898-5630



Project Manager:
LTC Tommie E. Newberry
ATTN: AMSAM-DSA-SH
C: 256-876-4927
DSN: 746-4927
newberry-te@redstone.army.com

Test, Measurement & Diagnostic Equipment Program Office USAAMCOM

Redstone Arsenal, AL 35898-5000



Program Manager:
COL Albert J. Hamilton, III
ATTN: AMSAM-DSA-TMDE
C: 256-876-4792;
DSN: 746-4792
hamilton-aj@redstone.army.mil

Unmanned Ground Vehicle/Systems Joint Project Office, USAAMCOM
Redstone Arsenal, AL 35898-5000
Director: COL C.K. (Ken) Curcio
ATTN: AMSAM-DSA-UG
C: 256-955-6995; DSN: 645-6995
curcio-ck@redstone.army.mil

Utility Helicopters Project Office, USAAMCOM

Redstone Arsenal, AL 35898-5000



Project Manager:
COL Thomas M. Harrison
ATTN: AMSAM-DSA-UH
C: 256-955-8938
DSN: 645-8938
harrison-tm@redstone.army.mil

Assistant Project Manager - UH-60Q:

LTC Eugene H. Pfeiffer
ATTN: AMSAM-DSA-UH
C: 256-955-0087; DSN: 645-0087
pfeiffer-eh@redstone.army.mil

Assistant Project Manager for Readiness: LTC Charles Cole

ATTN: AMSAM-OSA-UH
C: 256-955-0128; DSN: 645-0128
cole-cg@redstone.army.mil

Assistant Project Manager for Production Fielding: MAJ Bob Marion

ATTN: AMSAM-DSA-UH
C: 256-955-6545
marion-rl@redstone.army.mil

Weapons Systems Directorate, USAAMCOM

Redstone Arsenal, AL 35898-5000



Director:
COL Henry J. Atwood, Jr.
ATTN: AMSAM-DSA-W
C: 256-955-9947
DSN: 645-9947
atwood-hj@redstone.army.mil

Deputy Director: Mr. Milford H. Merritt, Jr.
ATTN: AMSAM-DSA-W
C: 256-876-6139; DSN: 746-6139
merritt-mh@redstone.army.mil

Avn. Ground Support Equipment Weapons System Mgr., WSD, USAAMCOM

Redstone Arsenal, AL 35898-5000



Acting Manager:
Mr. Robert L. White, III
ATTN: AMSAM-DSA-WAG
C: 256-842-9947
DSN: 788-9947
white-rl@redstone.army.mil

HAWK Weapon System Manager, WSD, USAAMCOM
Redstone Arsenal, AL 35898-5000



System Manager:
Dr. Robert S. Ball III
ATTN: AMSAM-DSA-WH
C: 256-876-4715
DSN: 746-4715
ball-rs@redstone.army.mil

Land Combat Systems Division, WSD, USAAMCOM

Redstone Arsenal, AL 35898-5000



System Manager:
Mr. Marshall F. White
ATTN: AMSAM-DSA-W
C: 256-876-1166
DSN: 746-1166
marshall-mf@redstone.army.mil

Aviation Research, Development & Engineering Center, USAAMCOM

Building 5681

Redstone Arsenal, AL 35898-5000



Executive Director:
Mr. Thomas L. House
ATTN: AMSAM-AR-Z
C: 256-313-1725
DSN: 897-1725
house-tl@redstone.army.mil

Associate Director for Technology:

Mr. Robert V. Kennedy
ATTN: AMSAM-AR-ZT
C: 256-313-1737; DSN: 897-1737
kennedy-rv@redstone.army.mil

Associate Director for Systems: Mr. John B. Johns

ATTN: AMSAM-AR-ZS
C: 256-313-1737; DSN: 897-1737
john-jb@redstone.army.mil

Associate Director for Technology Applications: Mr. John L. Shipley

ATTN: AMSAM-AR-ZN
C: 757-878-2000; DSN: 927-2000
shipley@eustis-aatds1.army.mil

Aviation Engineering Directorate, USAAMCOM

Redstone Arsenal, AL 35898-5000



Director of Engineering:
Mr. Barry J. Baskett
ATTN: AMSAM-AR-E
C: 256-313-4901
DSN: 897-4901
baskett-bj@redstone.army.mil

Acquisition Center, USAAMCOM
Bldg. 4488

Redstone Arsenal, AL 35898-5000



Executive Director:
Ms. L. Marlene Cruze
ATTN: AMSAM-AC
C: 256-876-7161
DSN: 746-7161
cruze-lm@redstone.army.mil

KAISER BUDDY START SYSTEM...

It's in the Bag

- Multiple uses for multiple aircraft
- Emergency starts & de-ice capabilities
- Can save lives, missions and aircraft



H-60 BLACKHAWK



AH-64 APACHE



BUDDY START SYSTEM
& DE-ICE NOZZLE

H-60 & AH-64 Buddy Start System
NSN 1730-01-424-1576
Kaiser P/N 0043-0034-3
De-Ice Nozzle Kaiser P/N 0096-0018



DE-ICE CAPABILITIES



C-130 HERCULES



SHOWS ACTUAL BUDDY START

KEP
KAISER
ELECTROPrecision

KAISER ELECTROPrecision
17000 South Red Hill Ave., Irvine, CA 92614-5676
Telephone: (714) 250-1015 Fax: (714) 250-0497 Web: www.KaiserEP.com

FOCUS
ON THE CUSTOMER

Deputy Director: COL James D. Hornaday
ATTN: AMSAM-AC
C: 256-876-7161; DSN: 746-7161
hornaday-jd@redstone.army.mil

Aviation & Missile RDEC Directorate, Acquisition Center, USAAMCOM
Bldg. 4488
Redstone Arsenal, AL 35898-5000
Director: Mr. W.G. "Bud" Bowersox
ATTN: AMSAM-AC-RD
C: 256-876-7307; DSN: 746-7307
bowersox-wg@redstone.army.mil

Aviation Logistics Support Dir., Acquisition Center, USAAMCOM
Bldg. 4488
Redstone Arsenal, AL 35898-5000
Director: Ms. Carol Lehman
ATTN: AMSAM-AC-AL
C: 256-955-7087; DSN: 645-7087
lehman-ca@redstone.army.mil

Business Management Office, Acquisition Center, USAAMCOM
Bldg. 4488
Redstone Arsenal, AL 35898-5000
Chief: Mr. Randy Richardson
ATTN: AMSAM-AC-BM
C: 256-876-7767; DSN: 746-7767
richardson-ra@redstone.army.mil

Missile Logistics Support Dir., Acquisition Center, USAAMCOM
Bldg. 4488
Redstone Arsenal, AL 35898-5000
Director: Ms. Dianne Landroop
ATTN: AMSAM-AC-ML
C: 256-876-9855; DSN: 746-9845
landroop-db@redstone.army.mil

PEO Aviation Directorate, Acquisition Center, USAAMCOM
Bldg. 4488
Redstone Arsenal, AL 35898-5000
Director: Ms. Rebecca Ulman
ATTN: AMSAM-AC-AV
C: 256-955-9232; DSN: 645-9232

Apache Division, Acquisition Center, USAAMCOM
Redstone Arsenal, AL 35898-5000
Chief: Mr. Robert M. Deppe
ATTN: AMSAM-AC-AV-A
C: 256-313-4063; DSN: 897-4063
depper@PeoAvn.redstone.army.mil

Comanche Division, Acquisition Center, USAAMCOM
Acquisition Center
Redstone Arsenal, AL 35898-5000
Chief: Mr. Bruce Metzger
ATTN: AMSAM-AC-AV-C
C: 256-313-4019; DSN: 897-4109

Acting Chief, Comanche/UH-60/CH-47 Division: Mr. James R. Lang
ATTN: AMSAM-AC-AL-A
C: 256-955-9198
lang_jr@redstone.army.mil

Chief, Spares Division: Mr. Vincent G. Thompson
ATTN: AMSAM-AC-AL-A
C: 256-955-7162; DSN: 645-7162

Chief, Support Services Division: Mr. Robert E. Butler
ATTN: AMSAM-AC-AL-A
C: 256-842-2392; DSN: 788-2392

PEO Tactical Missiles Directorate, Acquisition Center, USAAMCOM
Bldg. 4488
Redstone Arsenal, AL 35898-5000
Director: Mr. James Brannon
ATTN: AMSAM-AC-TM
C: 256-876-8406; DSN: 746-8406
brannon-je@redstone.army.mil

Systems Acquisition Air Dir., Acquisition Center, USAAMCOM
Bldg. 4488
Redstone Arsenal, AL 35898-5000
Director: Mr. Ronnie Noblitt
ATTN: AMSAM-AC-SM
C: 256-876-9317; DSN: 746-9317
noblitt-rd@redstone.army.mil

Systems Acquisition Missile Dir., Acquisition Center, USAAMCOM
Bldg. 4488
Redstone Arsenal, AL 35898-5000
Chief: Mr. Randy Richardson
ATTN: AMSAM-AC-BM
C: 256-876-7767; DSN: 746-7767
richardson-ra@redstone.army.mil

Integrated Materiel Management Center (IMMC), USAAMCOM
Sparkman Complex, Bldg. 5302
Redstone Arsenal, AL 35898-5000



Executive Director:
Mr. James L. Flinn III
ATTN: AMSAM-MMC
C: 256-876-3106
DSN: 746-3106
flinn-jl1@exchange1.redstone.army.mil

Deputy Director: Mr. John R. Chapman
ATTN: AMSAM-MMC
C: 256-876-3106; DSN: 746-3106
chapman-jr@redstone.army.mil

Air Defense Missile Directorate, (IMMC), USAAMCOM
Sparkman Complex, Bldg. 5302
Redstone Arsenal, AL 35898-5000
Director: Mr. Paul Carlton
ATTN: AMSAM-MMC-LS
C: 256-876-2392; DSN: 746-2392

Aviation Systems Directorate, (IMMC), USAAMCOM
Sparkman Complex, Bldg. 5302
Redstone Arsenal, AL 35898-5000
Director: Mr. Thomas Lavin
ATTN: AMSAM-MMC-VS
C: 256-313-1641; DSN: 897-1641

Directorate for Business Management, USAAMCOM
Redstone Arsenal, AL 35898-5000
Director: Mr. Daniel H. Kruvand
ATTN: AMSAM-MMC-BM
C: 256-876-8007; DSN: 746-8007
kruvand_dh@redstone.army.mil

Land Combat Missile Directorate, (IMMC), USAAMCOM
Sparkman Complex, Bldg. 5302
Redstone Arsenal, AL 35898-5000
Director: Mr. Tommie Cutts, Jr.
ATTN: AMSAM-MMC-LC
C: 256-876-3393; DSN: 746-3393

Logistics Support Directorate, (IMMC), USAAMCOM
Sparkman Complex, Bldg. 5302
Redstone Arsenal, AL 35898-5000
Director: Mr. Richard E. Turner
ATTN: AMSAM-MMC-LS
C: 256-876-5266; DSN: 746-5266

Readiness Directorate, (IMMC), USAAMCOM
Sparkman Complex, Bldg. 5302
Redstone Arsenal, AL 35898-5000
Director: Mr. William T. Ingram
ATTN: AMSAM-MMC-RE
C: 256-876-9818; DSN: 746-9818
ingram-wt@redstone.army.mil

Missile Research, Development & Engineering Center, USAAMCOM
Bldg. 5400
Redstone Arsenal, AL 35898-5000



Executive Director:
Dr. William C. McCorkle
ATTN: AMSAM-RD
C: 256-876-3322
DSN: 746-3322
mccorkle-wc@redstone.army.mil

U.S. Army Test, Measurement & Diagnostic Equipment Activity, USAAMCOM
Building 5435
Redstone Arsenal, AL 35898-5400



Executive Director:
Mr. Robert K. DuBois
ATTN: AMSAM-TMD
C: 256-876-1134
DSN: 746-1134
rdubois@redstone.army.mil

Corporate Information Center, USAAMCOM
Sparkman Complex, Bldg. 5303
Redstone Arsenal, AL 35898-5000



Corporate Information Officer:
Mr. Max Watson
ATTN: AMSAM-CIC
C: 256-876-2425
DSN: 746-2425
watons-mw@redstone.army.mil

Freedom of Information Officer: Ms. Vicki Weatherman
ATTN: AMSAM-CIC-OD-IS-RM
C: 256-876-5763; DSN: 746-5763
weatherman-vl@redstone.army.mil

Office, Project Manager, Joint Tactical Unmanned Aerial Vehicles
Redstone Arsenal, AL 35898-7459
Project Manager: COL Michael I. Howell
ATTN: SFAE-UAV
C: 256-895-4449; DSN: 788-4449
howell-uav@redstone.army.mil

ALASKA Bethel

Alaska ARNG Army Aviation Operating Facility #2
P. O. Box 7190
Bethel, AK 99559-0508
AASFC: MAJ Kenneth O. Snyder
ATTN: AKNG-AVN-OFB
C: 907-543-2225

Fort Greely

USAG Aviation Detachment
501 2nd Street
Fort Greely, AK 96508
Commander: CW5 Harry R. Ward
ATTN: APVR-FG-AO
C: 907-873-4170; DSN: 873-4170
wardh@green-emh1.army.mil
Operations Officer: CW2 Pewter Gorczok
C: 907-873-4170; DSN: 873-4170
apvrgao@greely-emh1.army.mil
Safety Officer: CW2 Keaton Wright
ATTN: APVR-FG-AO
C: 907-873-4170; DSN: 873-4170
Standardization Officer: CW4 Tom Struck
ATTN: APVR-FG-AO
C: 907-873-4170; DSN: 873-4170
apvrgao2@greely-emh1.army.mil
Senior NCO: SFC Dwaine E. Walters
ATTN: APVR-FG-AO
C: 907-873-1370; DSN: 873-1370
apvrgao@greely-emh1.army.mil

Fort Richardson

Arctic Support Brigade
600 Richardson Drive, #7600
Fort Richardson, AK 99505-7600
Commander: COL Robert A. Hammerle, Jr.
ATTN: APVR-RASB-CO
C: 907-384-0289; DSN: 317-384-0290
hammerle@richardson-emh2.army.mil
Executive Officer: LTC Thomas Blackburn
ATTN: APVR-RASB-XO
C: 907-384-0290; DSN: 317-384-0290
asbxo@richardson-emh2.army.mil
SIP: CW5 Myron Babcock
ATTN: APVR-WPTM-AV
C: 907-353-7097; DSN: 317-384-7097
avsafety@wainwright-emh1.army.mil
ASO: CW3 Danny Wruck
ATTN: APVR-WPTM-AV
C: 907-353-7098; DSN: 317-353-7098
wruckd@wainwright-emh1.army.mil
Aviation Maintenance Officer: Mr. Ron McIntosh
ATTN: APVR-WAB-AMO
C: 907-353-6029; DSN: 317-353-7098
asbavn@wainwright-emh1.army.mil
Senior NCO: CSM Daniel S. Brown
ATTN: APVR-RASB-CSM
C: 907-384-2723; DSN: 317-384-0290
asbcm@richardson-emh2.army.mil

Office, State Adjutant General, Alaska Army National Guard
P. O. Box 5800
Fort Richardson, AK 99505-5800



TAG:
MG Jacob Lestenkof
ATTN: OTAG
C: 907-428-6003
DSN: 384-4003
lestenkof@ak-army.ngb.army.mil

Litton APR-39B(V)1

SIGNIFICANT
PERFORMANCE
INCREASE

+

MINIMAL
"A-KIT"
IMPACT

+

IMPROVED
SITUATIONAL
AWARENESS

+

LOW COST
+
AVAILABLE
NOW!



INSTALLATION IMPACT

- Adds 1 **ADDITIONAL SMALL LRU**
- Substitutes some current APR-39A(V)1 LRUs/SRUs with **FORM FIT "PLUG AND PLAY"** replacements
- .15 cu. ft. Δ to the current APR-39A(V)1 system volume
- 10.9 lb. Δ to APR-39A(V)1 system weight
- **MINIMAL CABLING** changes
- **NO CHANGE** to cockpit configuration or ICS
- **FULL INTEGRATION** with laser and missile warning systems

CREW BENEFITS

- More **POSITIVE IDENTIFICATION** of threats
- Detection of **MODERN THREAT** systems
- Detection of **CW THREATS**
- Ability to handle a much **HIGHER THREAT DENSITY**
- Increased **PROCESSING** capability
- Built-in **GROWTH**
- Significant increase in **THREAT DETECTION RANGE**
- Improved **SITUATIONAL AWARENESS**
- Threats overlaid on **DIGITAL MAP**



Litton
Applied Technology

4747 Hellyer Avenue, P.O. Box 7012, San Jose, California 95150-7012
Contact: David Rossiter, Director, Business Development
U.S.A. TEL: 408 365-4168 FAX: 408 365-4040 Email: drossiter @ compuserve.com

Office, State Army Aviation Officer,
Alaska Army National Guard
Office of the Adjutant General
P.O. Box 5800
Fort Richardson, AK 99505-5800
SAAO: LTC Mark S. Stigar
ATTN: AKNG-AVN
C: 907-428-6902; DSN: 317-384-4902
SAOAK@AK-ARNG.NGB.ARMY.MIL

Alaska Army National Guard Army
Aviation Support Facility
P. O. Box A
Fort Richardson, AK 99505-5000
AASFC: MAJ Jerry Kidrick
ATTN: AKNG-AVN-SFC
C: 907-428-6310; DSN: 317-384-4310

1st Battalion, 207th Aviation
Regiment
Alaska Army National Guard
Fort Richardson, AK 99505
Commander: MAJ Richard S. Williams
ATTN: AKNG-AV
C: 907-428-6631; DSN: 384-4631
Executive Officer: MAJ Jerry A. Kidrick
ATTN: AKNG-AV
C: 907-428-6632; DSN: 384-4632
SIP: CW4 Terry Rollie
ATTN: AKNG-AV
C: 907-428-6330; DSN: 384-4330
ASO: CW4 Roger Stickney
ATTN: AKNG-AV-S
C: 907-428-6632; DSN: 384-4632
HHC Commander: CPT Brian Keese
ATTN: AKNG-AV-H
C: 907-428-6235; DSN: 384-4235
Company A Commander: CPT
Stephen Devereux
ATTN: AKNG-AVA-CO
C: 907-552-8958

Company B Commander: CPT
Michael Seine
ATTN: AKNG-AVB-CO
C: 907-552-5244
Company C: CPT Wayne Horton
ATTN: AKNG-AVC-CO
C: 907-443-2831
Company D: CPT Michael
Norton
ATTN: AKNG-AVD-CO
C: 907-552-5486
Company E: CPT Joseph Streff
ATTN: AKNG-AVE-CO
C: 907-428-6648; DSN: 384-4648
Senior NCO: CSM Dennis
Roggenkamp
ATTN: AKNG-AV-CSM
C: 907-428-6633; DSN: 384-4633

Fort Wainwright

Aviation Office, U.S. Army Alaska
(USARAK)
1060 Gaffney Road
Fort Wainwright, AK 99703
Aviation Officer: LTC Michael E.
Moody
ATTN: APVR-WPTM-AV
C: 907-353-9763; DSN: 317-353-9763
4123cdr@wainwright-emh5.army.mil
Deputy Aviation Officer: CW5 Myron
F. Babcock
ATTN: APVR-WPTM-AV
C: 907-353-7097; DSN: 317-353-7097
babcockm@wainwright-emh5.army.mil

4th Battalion, 123d Aviation
Fort Wainwright, AK 99703-8400



Commander:
LTC Michael E. Moody
ATTN: APVR-WAB-
CO
C: 907-353-9763
DSN: 317-353-9763
4123cdr@wainwright-
emh1.army.mil

Executive Officer: MAJ Robin D.
Lynch
ATTN: APVR-WAB-XO
C: 907-353-6064; DSN: 317-353-6064
4123bnxo@wainwright-emh1.army.mil
SIP: CW4 Pete Linn
ATTN: APVR-WAB-SIP
C: 907-353-7003; DSN: 317-353-7003
ASO: CW2 Mark Iig
ATTN: APVR-WAB-ASO
C: 907-353-7071; DSN: 317-353-7071



Senior NCO:
CSM Rene Versey
ATTN: APVR-WAB-
CSM
C: 907-353-9790
DSN: 317-353-9790

C Company, 123d Aviation (AVIM)
Fort Wainwright, AK 99703
Commander: MAJ Anthony W. Angelo
ATTN: APVR-WAB-AV
C: 907-353-1276; DSN: 317-353-1276
co123cdr@wainwright-emh1.army.mil
Senior NCO: 1SG Robert Williams
ATTN: APVR-WAB-AV
C: 907-353-1273; DSN: 317-353-1273

B Company, 4-123rd Theater Aviation
Regiment
Fort Wainwright, AK 99703
Commander: MAJ Jerold D. Bastian
ATTN: APVR-WAB-BCO
C: 907-353-9650; DSN: 317-353-9650
4123bcdr@wainwright-emh1.army.mil
SIP: CW3 Zane Hawkins
ATTN: APVR-WAB-BCO-SIP
C: 907-353-9963; DSN: 317-353-9963
47onskis@wainwright-emh1.army.mil
ASO: CW2 Kim Barney
ATTN: APVR-WAB-BCO-ASO
C: 907-353-6247; DSN: 317-353-9963
Senior NCO: 1SG Eric Harris
ATTN: APVR-WAB-BCO-CSM
C: 907-353-9652; DSN: 317-353-9652
4123bcdr@wainwright-emh1.army.mil

D Company, 4-123rd Theater Aviation
Regiment
Fort Wainwright, AK 99703
Commander: CPT Joseph S. Binnchi
ATTN: APVR-WAB-DCO
C: 907-353-7187; DSN: 317-353-7187
4123dcdr@wainwright-emh1.army.mil
SIP: CW3 Thomas Tatrow
ATTN: APVR-WAB-DCO-SIP
C: 907-353-6861; DSN: 317-353-6861
ASO: CW2 Bryan Buchanan
ATTN: APVR-WAB-DCO-ASO
C: 907-353-6861; DSN: 317-353-6861
Senior NCO: 1SG Stephen F. Sloskey
ATTN: APVR-WAB-DCO-1SG
C: 907-353-7066; DSN: 317-353-7066

68th Medical Company (AA) Alaska
Fort Wainwright, AK 99703
Commander: MAJ John Alvarez
ATTN: APVR-WAB-MD
C: 907-353-6283; DSN: 317-353-6283
cdr283@wainwright-emh1.army.mil
SIP: CW3 Dale Farr
ATTN: APVR-WAB-MD-SP
C: 907-353-6348; DSN: 317-353-6348
ASO: CW2 Kathleen Ryan
ATTN: APVR-WAB-MD-ASO
C: 907-353-7313; DSN: 317-353-7313
Senior NCO: 1SG Nancy Uptgraft
ATTN: APVR-WAB-MD
C: 907-353-6885; DSN: 317-353-6885

Juneau

Alaska Army National Guard Army
Aviation Operating Facility #4
8425 Livingston Way
Juneau, AK 99801-8086
AAOFC: CW3 David Small
ATTN: AKNG-ARV-OFJ
C: 907-789-3366

Nome

Alaska Army National Guard Aviation
Operating Facility #1
P. O. Box 533
Nome, AK 99762-0533
AAOFC: MAJ Leigh Crumpton
ATTN: AKNG-AVN-OFN
C: 907-443-2831

ARIZONA Fort Huachuca

Aviation Section, U.S. Army
Electronic Proving Ground
Fort Huachuca, AZ 85613-7110
Aviation Officer: Mr. James A. Hadley
ATTN: STEWS-EPG-AV
C: 520-538-2815; DSN: 879-2815
epgav@huachuca-emh16.army.mil

Marana

1-285th Aviation Attack Battalion
Silverbell Army Heliport
Pinal County Airpark
Marana, AZ 85653
Commander: CPT David Toon
ATTN: AZAA-AZMA
C: 520-616-5663; DSN: 853-5663
toon@az-armg.army.mil

Western Army National Guard
Aviation Training Site (WAATS)
Arizona ARNG
Silver Bell Army Heliport
Building L45-500
Marana, AZ 85653-9598



Commander:
COL George J. Gluski
ATTN: WAATS-C
C: 520-682-4504
DSN: 853-4504
gluskig@azng-
mail.army.mil

Deputy Commander: MAJ Dennis B.
Dray
ATTN: WAATS-C
C: 520-682-4546; DSN: 853-4546
SIP: CW4 Bruce McWhorter
ATTN: WAATS-F
C: 520-682-4547; DSN: 853-4586
ASO: CW4 Ronald Smith
ATTN: WAATS-SB
C: 520-682-4601; DSN: 853-4601
MTFE: CW3 Brad Frank
ATTN: WAATS-SB
C: 520-682-4648; DSN: 853-2700



Senior NCO:
CSM Robert Kimmell
ATTN: WAATS-C
C: 520-682-4503
DSN: 853-4503

Army Aviation Support Facility #2
Silverbell Army Heliport
Building L45-600
Marana, AZ 85653-9698
AASF #2: MAJ Kenneth E. Nettles
ATTN: AZAA-AVS
C: 520-616-5624; DSN: 853-4624
nettlesk@azng-mail.army.mil

Mesa

Defense Contract Mgmt. Command
The Boeing Company
5000 East McDowell Road
M.S. Bldg 510, A277
Mesa, AZ 85215



Commander:
LTC David P. Miller
ATTN: DCMC-GPOM
C: 602-891-3500
DSN: 474-3500
dpmiller@swest.
dcmwd.dla.mil

Phoenix

C Company, 1-189th Aviation
Battalion
5636 E. McDowell Road
Phoenix, AZ 85008-3495
Commander: CW4 Robert Dubasik
ATTN: AZAA-AZKJ-ZA
C: 602-267-2860; DSN: 853-2860
dubasikr@az-armg.army.mil

E Company, 1-189th Aviation
Battalion
5636 E. McDowell Road
Phoenix, AZ 85008-3495
Commander: SFC Steve Daniel
ATTN: AZAA-AZKM-ZA
C: 602-267-2312; DSN: 853-2312
EM: daniels@az-armg.army.mil

2/98th Troop Command
1335 N. 52nd Street
Phoenix, AZ 85008-3495
Commander: MAJ Elizabeth
Montgomery
ATTN: AZAA-AZKA
C: 602-267-2518; DSN: 853-2855

CAREFUL. IT'S LOADED.



Today's T700 comes loaded with unmatched experience and the best customer value – delivering affordable, reliable performance to all of the Army's Black Hawks and Apaches. Tomorrow's turboshaft will come loaded with all the T700's rugged durable features – plus demonstrated technology from GE and Army-sponsored JTAGG programs.

GE's advanced turboshafts are just one example of our commitment to the future of military aviation. Programs in support of advanced helicopters and next-generation aircraft like the Navy's Super Hornet and the multi-service Joint Strike Fighter come loaded not only with the latest in technology, but with a commitment to bring the lowest risk and highest value to our customers.



GE Aircraft Engines

38th Attack Regiment
5636 E. McDowell Road
Phoenix, AZ 85008-3495
Commander: SGM Frank Sandell
ATTN: AZAA-AZKA
C: 602-267-2855; DSN: 853-2855
EM: sandellf@az-armg.army.mil

416th ATSC (DIV)
5636 E. McDowell Road
Phoenix, AZ 85008-3495
Commander: SSG Craig Murray
ATTN: AZAA-AZKG
C: 602-267-2847; DSN: 853-2847
georget@az-armg.army.mil

**Office, State Adjutant General,
Arizona Army National Guard**
5636 East McDowell Road
Phoenix, AZ 85008-3495
TAG: MG Glen W. Van Dyke
C: 602-267-2710; DSN: 853-2710

**Office, State Army Aviation Officer,
Arizona Army National Guard
Office of the Adjutant General**
5636 East McDowell Road
Phoenix, AZ 85008-3495



SAAO:
COL Bruce R. Bodin
ATTN: AZAA-AV
C: 602-267-2864
DSN: 853-2864
bodlnb@azng-
mail.army.mil

**Arizona Army National Guard
Aviation Support Facility #1**
5636 East McDowell Road
Phoenix, AZ 85008-3495
AASFC: LTC Jack T. Ogle
ATTN: AZAA-AVL
C: 602-267-2794; DSN: 853-2638
oglej@azng-mail.army.mil

ARKANSAS North Little Rock

**Office, State Adjutant General,
Arkansas Army National Guard**
Camp Robinson
North Little Rock, AR 72199-9600



TAG:
MG Don C. Morrow
TAG-Z
C: 501-212-5100
DSN: 962-5100
tag@ar-ngnet.army.mil

**Office, State Army Aviation Officer,
Arkansas Army National Guard
Army Aviation Support Facility**
Camp Robinson
North Little Rock, AR 72199-9600



SAAO:
COL Charles H.
Wilson
ATTN: TAG-DASF-D
C: 501-212-5650
DSN: 962-5650
saocar@ar-ngnet.
army.mil

**Arkansas Army National Guard Army
Aviation Support Facility**
Camp Robinson
North Little Rock, AR 72199-9600
AASFC: COL William R. Holland
ATTN: TAG-DASF-C
C: 501-212-5656; DSN: 962-5656
aasf1@ar-ngnet.army.mil

CALIFORNIA Fort Irwin

**U.S. Army Air Ambulance
Detachment**
Fort Irwin, CA 92310-5000
Commander: LTC Bryant H. Aldstadt
ATTN: AFZJ-SB-MD
C: 760-380-3082; DSN: 470-3082
aldstadb@irwin.army.mil

**Operations Group, Aviation Trainer
Division, NTC**
Fort Irwin, CA 92310-5000
Senior Aviation Trainer: LTC Greg
Williamitis
ATTN: ATXY-AV
C: 619-380-4461; DSN: 470-4461
Combat Service Support Trainer:
MAJ Ron Miller
ATTN: ATXY-AV
C: 619-380-4462; DSN: 470-4462

Senior Aviation Bde Trainer: MAJ
Terry Jamison
ATTN: ATXY-AV
C: 619-380-5544; DSN: 470-5544
Attack Battalion Operations Trainer:
MAJ Brian Thoma
ATTN: ATXY-AV
C: 619-380-5544; DSN: 470-5544
Senior TAF Analyst: MAJ Steve
Beltsen
ATTN: ATXY-AV
C: 619-380-5090; DSN: 470-5090
Senior NCO: SGM Joseph Tainatonga
ATTN: ATXY-AV
C: 619-380-3504; DSN: 470-3504

Fresno

**40th Infantry Division Aviation
Brigade, California ARNG**
911 South Chance Avenue
Fresno, CA 93702



Commander:
COL Michael A. Smith
ATTN: CADD-CR
C: 209-253-7029
ssd700@quiknet.com

Executive Officer: LTC James Berdan
ATTN: CADD-XO
C: 209-253-7029
jberdan@aol.com

ASO: CW4(P) Roy Lineberry
ATTN: CADD-ASO
C: 209-253-7029
hueyroy@aol.com
SIP: CW4(P) Greg Helsel
ATTN: CADD-SP
C: 209-253-7025
ch47sp@aol.com
TAC OPS: CW5 John Harris
ATTN: CADD-TO
C: 209-253-7025
harris4592@aol.com
MTFE: CW4(P) William Scott
ATTN: CADD-ME
C: 916-854-3824; DSN: 466-3824
scottw@calguard.ca.gov
Senior NCO: CSM B. J. Liewellen
ATTN: CADD-CSM
C: 209-253-7020
csmbj@inreach.com

**1106th Aviation Classification Repair
Activity Depot (AVCRAD)**
California ARNG
5168 East Dakota Avenue
Fresno, CA 93727-7404
Supervisor: COL Brad Jones
ATTN: CAFR-CR
C: 209-454-5352; DSN: 949-9352
avcradca@ca-ngnet.army.mil

Los Alamitos

**Aviation Support Facility Los
Alamitos**
Building 912, AFRC
11200 Lexington Drive
Los Alamitos, CA 90720-5002
Facility Supervisor: Mr. J. Bruce
Bolton
ATTN: AFRC-ACA-ASF
C: 310-795-2235; DSN: 972-2235

**Los Alamitos Army Aviation Support
Facility #1**
Armed Forces Reserve Center
Building 913
11200 Lexington Drive
Los Alamitos, CA 90720-5001
AASFC: MAJ Carl Allen
ATTN: LAAASF
C: 562-795-2001; DSN: 972-2001

**California Army National Guard Los
Alamitos Army Airfield**
Armed Forces Reserve Center
Airfield Operations, Bldg. 1
Los Alamitos, CA 90720-5001



Airfield Commander:
LTC Thomas E.
Lasser
ATTN: CALA-LAAAF-
CDR
C: 562-795-2561
DSN: 972-2561:
LasserT@
CALGUARD.CA.GOV

Aviation Safety Officer: CW3 Chris
Trautwein
ATTN: CALA-LAAAF-SO
C: 562-795-2564; DSN: 792-2564
Pol Supervisor: 1SG Herbert Irizarry
ATTN: CALA-LAAAF-POL
C: 562-795-2149; DSN: 972-2149
Senior NCO: SSG(P) Troy Eck
ATTN: CALA-LAAAF-FS
C: 562-795-2571; DSN: 972-2571

Mather

126th Medical Company (AA)
10616 Superfortress Avenue
Mather, CA 95655-1103
Commander: MAJ Manuel A. Lascano
C: 916-843-3975

**California Army National Guard
Aviation Support Facility #3**
10626 Superfortress Avenue
Mather, CA 95655-1103
AASFC: MAJ Manuel A. Lascano
ATTN: AASF-SAC
C: 916-854-3633; DSN: 466-3090

Moffett Field

**National Rotorcraft Technology
Center**
Ames Research Center
M/S 207-1
Moffett Field, CA 94035-1000



Director:
Mr. C. Thomas Snyder
ATTN: Code N
C: 415-604-5066
DSN: 359-5066
tom_snyder@qmgate.
arc.nasa.gov

Deputy Director: Mr. John M. Davis
ATTN: Code N
C: 415-604-5375; DSN: 359-5375
davis@merlin.arc.nasa.gov

**Aeroflightdynamics Directorate,
USAAFCOM**
NASA Ames Research Center
Moffett Field, CA 94035-1000



Director:
Mr. Andrew W. Kerr
ATTN: AMSAM-AR-A
C: 650-604-5837
DSN: 359-5837
akerr@mail.
arc.nasa.gov

Deputy Director: Mr. Wayne D. Mosher
ATTN: AMSAM-AR-A
C: 650-604-5569; DSN: 359-5569
mosher@merlin.arc.nasa.gov
Chief, Research Support Division:
Mr. Arthur Ragosta
ATTN: MS 219-1
C: 650-604-5558; DSN: 359-5558
ragosta@merlin.arc.nasa.gov

Sacramento

**Office, State Adjutant General,
California ARNG**
9800 S. Goethe
Sacramento, CA 95826-9101



TAG:
MG Tandy K.
Bozeman
C: 916-854-3500
DSN: 466-3500



1 Black Hawk. 2 Minutes. 3 Missions.

Air Methods, the nation's leading provider of air medical products, is extremely proud to have our uniquely designed Multi-Mission MEDEVAC System selected for the U.S. Army UH-60Q Black Hawk. ★ Our Multi-Mission MEDEVAC System converts from personnel transport to MEDEVAC in less than 2 minutes. Then converts from MEDEVAC to cargo transport in less than 2 minutes. All without removing or replacing any equipment. ★ We proved how Air Methods' Multi-Mission MEDEVAC System can fly a 6-member medical team into a forward area, convert to evacuate 6 wounded as fast as they can be on-loaded, and then convert to transport cargo back to the forward area! There's no dead-heading with the Air Methods System. One aircraft performs 3 missions. ★ Call Air Methods and we'll convert you in less than 2 minutes, too.

**Air Methods**
PRODUCTS DIVISION

Time flies.

7301 South Peoria
Englewood, CO 80112, U.S.A.
303-792-7400
Fax: 303-790-0499

Office, State Army Aviation Officer,
California ARNG
Chief, Aviation and Safety
Office of the Adjutant General
P.O. Box 269101
9800 Goethe Rd.
Sacramento, CA 95826-9101
SAAO: LTC Daniel J. Nelan
ATTN: CAAV
C: 916-854-3096; DSN: 466-3096
neland@calguard.ca.gov

Stockton

California Army National Guard Army
Aviation Support Facility #2
Stockton Metropolitan Airport
2000 Stimson Road
Stockton, CA 95206-3997
AASFC: LTC James L. Berdan
ATTN: COMMANDER
C: 209-938-5311; DSN: 466-5311

COLORADO Aurora

1022d Medical Company,
Detachment 1
770 S. Aspen Street
Buckley ANG Base
Aurora, CO 80011-9552
Commander: CPT Dryden Boyce
ZA BA1
C: 303-677-6328; DSN: 877-6328

Office, State Army Aviation Officer,
Colorado Army National Guard
Buckley Air NG Base
800 S. Aspen Road
Aurora, CO 80011-9553



SAAO:
LTC Shawn W. Flora
ATTN: COASF
C: 303-677-9844
DSN: 877-9844
saoco-ngnet.army.mil

Englewood

Office, State Adjutant General,
Colorado Army National Guard
6848 S. Revere Parkway
Englewood, CO 80112-6703



TAG:
MG William A.
Westerhdahl
ATTN: TAG
C: 303-397-3023
DSN: 877-2023
mpalkovich@cobkf.
ang.af.mil

Fort Carson

4th Squadron, 3rd Armored Cavalry
Regiment
Building 2350
Fort Carson, CO 80913
Commander: LTC B. Shannon Davis
ATTN: AFZC-R-H-CO
C: 719-526-2564; DSN: 691-2564
Executive Officer: MAJ Ronald K.
Taylor
ATTN: AFZC-R-H-XO
C: 719-524-1763; DSN: 883-1763
SIP: CW4 Stephen Bergstrom
ATTN: AFZC-R-H-C
C: 719-526-2332; DSN: 691-2332
ASO: CW3 Kenneth Young
ATTN: AFZC-R-H-A
C: 719-526-2635; DSN: 691-3873

Senior NCO: CSM Douglas Murray
ATTN: AFZC-R-H-CSM
C: 719-526-2635; DSN: 691-2635

571st Medical Company (Air
Ambulance)
Fort Carson, CO 80913-5000
Commander: MAJ Robert A. Eaton
ATTN: AFZC-Y-MD-MED
C: 719-526-6497; DSN: 691-6497

Gypsum

High Altitude Training Site (HATS)
P.O. Box 453
Gypsum, CO 81637-0453
Commander: MAJ Joel Best
C: 970-524-7704; DSN: 877-2223

CONNECTICUT Enfield

1st Battalion, 169th Aviation
National Guard Armory
1635 King Street
Enfield, CT 06082-5824
Commander: LTC Ernest T. Erickson
ATTN: CTTC-AVN-CDR
C: 203-386-5501
eerickson@silorsky.com
Executive Officer: MAJ Thomas J.
Sousa
ATTN: CTTC-AVN-XO
C: 860-745-1951

Safety Officer: CW4 Michael D. Vollero
ATTN: CTTC-AVN-SAF
C: 860-741-5487
MTFE: 2LT Victoria Welch
ATTN: CTTC-AVN-MTFE
C: 860-627-4881; DSN: 636-8728

Senior NCO: CSM Duane I.
Haverstock
ATTN: CTTC-AVN-CSM
C: 860-745-1951

Groton

1109th Aviation Classification Repair
Activity Depot (AVCRAD)
Connecticut ARNG
139 Tower Avenue
Groton-New London Airport
Groton, CT 06340-5300
Supervisor: COL Thomas N. Bordner
C: 860-441-2900; DSN: 636-7925

Hartford

Office, State Adjutant General,
Connecticut ARNG
360 Broad Street
Hartford, CT 06105-3795



TAG:
MG David W. Gay
CTNG-TAG
C: 860-524-4953
DSN: 636-7953
gaydw@ct-armg.ngb.
army.mil

Trumbull

TSM-Comanche (FWD)
35 Nutmeg Drive
MS/Z112-Sikorsky
Trumbull, CT 06611-5415
Asst TSM-C (Logistics): CW5 Bill
Harrison
ATTN: ATZQ-TSM-C(FWD)
C: 203-383-3788
bill_harrison@rucker-emh4.army.mil

Asst TSM-C (Crew Station): CW3
Andy Johnson
ATTN: ATZQ-TSM-C(FWD)
C: 203-383-3740
Asst TSM-C (Maintenance): Master
Sergeant Paul Sargent
ATTN: ATZQ-TSM-C(FWD)
C: 203-383-3672

Windsor Locks

2d Battalion, 126th Avn. Regiment
CT Army National Guard
Camp Hartell, Bldg. P-123
Windsor Locks, CT 06096-0455
Commander: MAJ Christopher R. Ward
ATTN: CTASG-AVN-CO
C: 860-386-4045; DSN: 656-7045
wardcr@ct-armg.ngb.army.mil
Executive Officer: MAJ Thomas Boland
ATTN: CTASG0-AVN-XO
C: 860-386-4075; DSN: 636-7075
bolandte@ct-armg.ngb.army.mil
SIP: CW4 Douglas D. Duguay
ATTN: CTASG-AVN-BCO
C: 860-386-4080; DSN: 636-7080
duguaydd@ct-armg.ngb.army.mil
ASO: CW3 Renato R. Astolfi
ATTN: CTBD-AVN-SO
C: 860-386-4080; DSN: 636-7080
astolfirr@ct-armg.ngb.army.mil
MTFE: CW2 Michael M. Kermod
ATTN: CTASG-AVN-DCO
C: 860-386-4082; DSN: 636-7082
kermodemm@ct-armg.ngb.army.mil
Senior NCO: CSM Robert A. Ricciuti
ATTN: CTASG-AVN-CSM
C: 860-386-4045; DSN: 636-7045
ricciutira@ct-armg.ngb.army.mil

Office, State Army Aviation Officer,
Connecticut ARNG
Director, Aviation Operations
CTARNG
360 Broad St.
Hartford, CT 06105-3795
SAAO: COL Albert A. Rubino
ATTN: MCTGC-SAO
C: 860-524-4855; DSN: 636-7855

Connecticut Army National Guard
Army Aviation Support Facility
Building 152
Bradley Int'l Airport
Windsor Locks, CT 06096-1086
AASFC: MAJ Mark H. Rousseau
ATTN: MCTGC-SAO
C: 860-386-4072; DSN: 636-8728

D.C. Washington

121st Medical Company (AA)
DCARNG
2001 E. Capitol Street
Washington, DC 20003-1719

Office, Directorate for Defense
Research & Engineering (ODDR&E)
3080 Defense Pentagon
Washington, DC 20301-3080



Deputy Director:
Mr. George T. Singley III
ATTN: DDR&E
C: 703-695-0598
DSN: 225-0598
singlegt@acq.osd.mil

Aviation/IEW Directorate, OASARDA
103 Army Pentagon
Washington, DC 20310-0103



Director:
COL Joseph E.
Panchak
ATTN: SARD-SA
C: 703-614-7905
DSN: 224-7905

Aviation Staff Officer
HQ, Department of the Army
200 Army Pentagon
Washington, DC 20310-0200
Aviation Staff Officer: MAJ James A.
Muskopf
ATTN: DACS-DMC-A, Room 3D614
C: 703-697-2009; DSN: 227-2009
muskoja@hqda.army.mil

Office, ADCSOPS for Force
Development
460 Army Pentagon
Washington, DC 20310-0460

ADCSOPS for Force Development:
BG(P) Joseph M. Cosumano, Jr.
ATTN: DAMO-FD, Room 3A522
C: 703-697-5116
DSN: 227-5116

Requirements Directorate, ADCSOPS
for Force Development, ODCSOPS
460 Army Pentagon
Washington, DC 20310-0460
Director of Requirements: BG John P.
Rose
ATTN: DAMO-FDZ
C: 703-695-3611; DSN: 225-3611

Army Aviation Division, ODCSOPS
Washington, DC 20310-0460
Division Chief: COL Roger E.
McCauley
Room 1A873, ATTN: DAMO-FDV
C: 703-695-7415; DSN: 225-7415
Secretary: Ms. Sheila Page
ATTN: DAMO-FDV
C: 703-697-9666; DSN: 227-9666
pagesh@dcsops01.army.mil

Support Team, Army Aviation Div.,
ODCSOPS
Washington, DC 20310-0460
Executive Officer: LTC J. Darnell
Room 1A873, ATTN: DAMO-FDV
C: 703-614-2065; DSN: 224-2065

SI Core Programs
(ASE/AGSE/ALSE/ATC/NV/Avionics):
LTC S. Mauro
ATTN: DAMO-FDV
C: 703-695-7439; DSN: 225-7439

Utility/Cargo Team, Army Aviation
Div., ODCSOPS
Washington, DC 20310-0460
Team Chief/Organizational Integrator:
LTC Doug Germann
Room 1A873, ATTN: DAMO-FDV
C: 703-697-9667; DSN: 227-9667
germadh@dcsops01.army.mil



Great leaders *earn* their positions.

At Sabreliner, we believe a leadership position
can't just be assumed...it must be earned.

Earned by providing decades of high quality service
to the United States Government.

Earned by continuously improving our conveniently
located facilities.

Earned by talented, seasoned professionals
who value the importance of doing
the job right.

Earned by accomplishing work correctly,
on time, every time.

Earned from our constant dedication
to controlling costs.

SABRELINER
CORPORATION

Leadership earned
through experience.

Phone (314) 863-6880 Fax (314) 863-6844

SI (UH-60/UH-1C2 Console): LTC Steve Engabretson
ATTN: DAMO-FDV
C: 703-697-9668; DSN: 227-9668

SI (CH-47/ARs/Safety): CW5 Donn Olson
ATTN: DAMO-FDV
C: 703-695-9636; DSN: 225-9636
olsond@dcsop01.army.mil

SI (Fixed Wing): CW5 Rowlands
ATTN: DAMO-FDV
C: 703-693-3253; DSN: 223-3253

Of: LTC Doug Germann
ATTN: DAMO-FDV
C: 703-697-9667; DSN: 227-9667
germadh@dcsop01.army.mil

Scout/Attack Team, Army Aviation Division, ODCSOPS
Washington, DC 20310-0460

Team Chief & SI (Comanche/OH-58D): LTC Kevin Scherrer
Room 1A873, ATTN: DAMO-FDV
C: 703-693-4516; DSN: 223-4516
scherkg@dcsop01.army.mil

SI (AH-1/AH-64/Longbow): LTC William F. Jernigan
ATTN: DAMO-FDV, Room 1A873
C: 703-614-2360; DSN: 224-2360
jernwif@dcsop01.army.mil

SI (Munitions & Simulation): LTC Tom DeVine
ATTN: DAMO-FDV
C: 703-695-0091; DSN: 225-0091
devintj@dcsop01.army.mil

RAH-66 Analyst: Mr. Bill Beletsky
ATTN: DAMO-FDV
C: 703-697-1879; DSN: 227-1879
beletsk@dcsop01.army.mil

Systems Analyst: Mr. Jim Waters
ATTN: DAMO-FDV
C: 703-695-0091; DSN: 225-0091
wallerjk@dcsop01.army.mil

Aviation Logistics Division, ODC-SLOG, HQDA
500 Army Pentagon
Washington, DC 20310-0500

Chief: COL Alfred J. Naigle
ATTN: Room 1E572 DALO-AMV
C: 703-697-0487; DSN: 227-0487
naigljaj@hqda.army.mil

Secretary: Ms. Charmaine E. West
ATTN: DALO-AMV
C: 703-697-0487; DSN: 227-0487
westce@hqda.army.mil

Aviation Logistics Management Specialist: Ms. Dorothy A. Downing
ATTN: DALO-AMV
C: 703-697-0487; DSN: 227-0487
downida@hqda.army.mil

Aviation Weapons Systems Logistics Officer: LTC William C. Jahn
ATTN: DALO-AMV
C: 703-697-0487; DSN: 227-0487
jahnwc@hqda.army.mil

Aviation Logistics Support Officer: LTC Carl D. Wiley
ATTN: DALO-AMV
C: 703-697-0487; DSN: 227-0487
wileycd@hqda.army.mil

Aviation Weapons Systems Logistics Officer: MAJ John E. James
ATTN: DALO-AMV
C: 703-697-0487; DSN: 227-0487
jamesje@hqda.army.mil

Aviation Weapons Systems Support & Safety Officer: CW4 James L. Kelly
ATTN: DALO-AMV
C: 703-697-0487; DSN: 227-0487
kellyjl@hqda.army.mil

Logistics Management Specialist: Ms. Marjorie E. Hendren
ATTN: DALO-SMV
C: 703-697-0487; DSN: 227-0487

Directorate for Supply & Maintenance, ODCSLOG
500 Army Pentagon
Washington, DC 20310-0500



Director: MG Julian A. Sullivan, Jr.
Room 2E554, ATTN: DALO-SMZ-A
C: 703-697-8401
DSN: 227-8401
sullija@hqda.army.mil

Plans Division, ODCSPER
300 Army Pentagon
Washington, DC 20310-0300

Aviation Personnel Systems Staff Officer: LTC Robert W. Kenneally
Room 2B673, ATTN: DAPE-PRP-CA
C: 703-697-5864; DSN: 227-5864
kennew@hqda.army.mil

Operations, Readiness & Force Development Division, OCAR
The Pentagon
Washington, DC 20310-2400

Aviation Officer: MAJ David E. LeBlanc
ATTN: DAAR-OFD-FD
C: 703-696-5190; DSN: 426-5190
leblanc@ocar.army.pentagon.mil

Aviation Force Integrator: MAJ David E. LeBlanc
ATTN: DAAR-OFD-FD
C: 703-696-5190; DSN: 426-5190
leblanc@ocar.army.pentagon.mil

Aviation Logistics Officer: Mr. Rodger Nash
ATTN: DAAR-LO
C: 703-696-5175; DSN: 426-5175
nash@pentagon-ocar1.army.mil

Office, Commanding General, District of Columbia ARNG
2001 Capitol Street
Washington, DC 20003-1719



TAG: MG Warren L. Freeman
DCNG-CG
C: 202-433-5220
DSN: 288-5220
tagdc@dc-arng.ngb.army.mil

Office, Director of Army Safety
The Pentagon
Washington, DC 20310

Deputy Dir.: COL William P. Dickens
ATTN: DACS-SF, Room 3D253
C: 703-695-7291; DSN: 225-7291

DELAWARE New Castle

Office, State Army Aviation Officer, Delaware Army National Guard Army Aviation Support Facility
33 Corporate Circle
New Castle, DE 19720-2493
SAAO/AASFC: COL David R. Ham
C: 302-326-7200; DSN: 440-7200
HamD@de-smtp.ngb.army.mil

Wilmington

Office, State Adjutant General, Delaware Army National Guard
First Regiment Road
Wilmington, DE 19808-2191



TAG: MG George K. Hastings
ATTN: DE-TAG
C: 302-326-7001
DSN: 440-7001
hastings@de-smtp.ngb.army.mil

FLORIDA Lakeland

Florida Army National Guard Army Aviation Support Facility #2
3600 Drane Field Road
Lakeland, FL 33811-1278
AASFC: CPT Lewis M. Hersey
ATTN: AASF #2
C: 941-648-3220
aasfz@fl-arng.ngb.army.mil

MacDill Air Force Base Plans, Policies & Strategic Assessments, J-5/J-7, USSOCM
7701 Tampa Point Boulevard
MacDill Air Force Base, FL 33621-5323
Director: BG (P) Bryan D. Brown
C: 813-828-3031; DSN: 968-3031

Orlando

Aviation Support Facility Orlando
10730 Tradeport Drive
Orlando, FL 32827-5399
Facility Supervisor: Mr. Patrick I. Maroney
C: 407-856-6150; DSN: 791-3592

U.S. Army Simulation, Training & Instrumentation Cmd. (STRICOM)
12350 Research Parkway
Orlando, FL 32826-3276

Commanding General: BG William L. Bond
ATTN: AMSTI-CG
C: 407-384-3501
DSN: 970-3501
geisj@stricom.army.mil

Deputy Commander: Mr. James M. Skurka
ATTN: AMSTI-DC
C: 407-384-3502; DSN: 970-3502
skurkaj@stricom.army.mil

Project Manager, Training Devices (TRADE), STRICOM
12350 Research Parkway
Orlando, FL 32826-3276

Project Manager: COL Craig B. Hanford
ATTN: AMCPM-TND
C: 407-384-5200; DSN: 970-5200
hanfordc@stricom.army.mil

Product Manager, Ground Combat Training Systems (GCTS), STRICOM
12350 Research Parkway
Orlando, FL 32826-3276

Product Manager: LTC Matthew J. Fair
ATTN: AMCPM-GCTS
C: 407-384-5160; DSN: 970-5160
fairm@stricom.army.mil

Product Manager, Combat Support Training Systems (CSTS), STRICOM
12350 Research Parkway
Orlando, FL 32826-3276

Product Manager: LTC Stephen Kessinger
ATTN: AMCPM-CSTS
C: 407-380-8181; DSN: 960-8181
kessings@stricom.army.mil

Product Manager, Air & Command Training System (ACTS), STRICOM
12350 Research Parkway
Orlando, FL 32826-3276

Product Manager: LTC Robert Hallagan
ATTN: AMCPM-ACTS
C: 407-384-5140; DSN: 970-5140
hallagar@stricom.army.mil

PM, Warfighters' Simulation (WAR-SIM), STRICOM
12350 Research Parkway
Orlando, FL 32826-3276



Project Manager: COL Michael Rogers
ATTN: AMSTI-PMWARSIM
C: 407-384-3650
DSN: 970-3650
Rogersm@stricom.army.mil

Office, PM Combined Arms Assess. Network (PM CAAN), STRICOM
12350 Research Parkway
Orlando, FL 32826-3276

Product Manager: LTC Clement E. Greek
ATTN: AMCPM-CAAN
C: 407-384-3656; DSN: 970-3656
clem_greek@stricom.army.mil

PM, Instrumentation, Targets & Threat Simulators, (ITTS), STRICOM
12350 Research Parkway
Orlando, FL 32826-3276



Project Manager: COL Mark W. Russell
ATTN: AMCPM-ITTS
C: 407-384-5250; DSN: 970-5250
russellm@stricom.army.mil



It's ready to earn more stripes.

For more than 30 years, the T55 engine has given the U.S. Army's Chinook helicopters all the power they've needed, whenever they've needed it. Now, the upgraded T55-GA-714A is ready to carry the Chinook tradition into the next 30 years.

Today's Army mission demands a versatile helicopter with more power, longer range and greater payload capability. It also requires a fleet of helicopters that are easy to maintain and efficient to operate.

The T55-GA-714A exceeds all of these requirements. It has 20% more power, 5% better SFC, 30% lower O&S costs, a projected 131% increase in unscheduled MTBR, and logistics support already in place. More important, the T55-GA-714A is ready to enter service now, with the core engine already field-tested aboard the SOA MH47E.



Tough, reliable, cost-effective and ready to go now. The T55-GA-714A is the best solution for the Army's expanded mission requirements.

 **AlliedSignal**
AEROSPACE

<http://www.alliedsignal.com/aerospace>

Project Manager, Combined Arms Tactical Trainer (CATT), STRICOM
12350 Research Parkway
Orlando, FL 32826-3275



Project Manager:
COL Alan R. Hammond
ATTN: AMSTI-CATT
C: 407-384-3600
DSN: 970-3600
Alan_Hammond@stri-com.army.mil

St. Augustine

Office, State Adjutant General, Florida Army National Guard
P. O. Box 1008
St. Augustine, FL 32085-1008



TAG:
MG Ronald O. Harrison
C: 904-823-0100
DSN: 860-7100
harrisonr@fl-armg.ngb.army.mil

Office, State Army Aviation Officer, Florida Army National Guard Department of Military Affairs State Aviation Officer
P.O. Box 1008
St. Augustine, FL 32085-1008
SAAO: COL John C. Holland
ATTN: SAAO
C: 904-823-0475; DSN: 860-7475
saoff@fl-armg.ngb.army.mil

GEORGIA Atlanta

Office, State Adjutant General, Georgia Army National Guard
P. O. Box 17965
Atlanta, GA 30316-0965



TAG:
MG William P. Bland
C: 404-624-6001
DSN: 338-6001
tagga@ga-armg.ngb.army.mil

Atlanta Regional Flight Center
4185 M.L. King Jr. Drive, NW
Atlanta, GA 30336-1696
Commander: MAJ Thomas M. Stewart
ATTN: OSAC-GA
C: 404-691-2500; DSN: 367-4271
dsacomga@armgrc-emh2.army.mil

Dobbins ARB

Dobbins Air Reserve Base Aviation Support Facility Dobbins
1613 Hull Place
Dobbins Air Force Base, GA 30069-5102
Facility Supervisor: Mr. Scott Cochran
C: 770-919-5644; DSN: 925-5284

Georgia Army National Guard Army Aviation Support Facility #2
900 Atlantic Avenue, Bldg. 555
Dobbins Air Reserve, GA 30069-4305
AASFC: CW5 Rickie L. Barron
ATTN: AASF #2
C: 770-919-3443; DSN: 925-3443

Ellenwood

Office, State Army Aviation Officer, Georgia Army National Guard
Dept of Defense, Military Div.
P.O. Box 746
Englewood, GA 30294-0746
SAAO: COL Dannis E. Livingston
ATTN: DCS-AVN
C: 404-675-5066; DSN: 573-6066
saoga@ga-armg.ngb.army.mil

Forest Park

Aviation Branch, Tng. Spt. Mgt. & Ex. Div., DCST, First U.S. Army
4705 N. Wheeler Drive
Forest Park, GA 30297-5000



Chief:
MAJ George A. Amonette
C: 404-362-7733
DSN: 797-7733
amonetg@gillem-emh1.army.mil

Senior Army Aviation Officer: LTC Chuck Ladd
C: 404-363-5299; DSN: 797-5299
NCOIC: MSG Stephen Moody
C: 404-362-7358; DSN: 797-7358

Fort Benning

U.S. Army Infantry School, Aviation Division Directorate of Operations & Training
Fort Benning, GA 31905
Division Chief & Lawson AAF Commander: MAJ Daniel R. Shea
ATTN: ATSH-OTA
C: 706-545-1281; DSN: 835-1281

498th Medical Company (Air Ambulance)
Fort Benning, GA 31905-5900
Commander: MAJ Vincent C. Camazza Jr.
ATTN: AFBK-498
C: 404-545-5311; DSN: 835-5311

Fort McPherson

Plans Logistics, Operations & Training (PLOT) Div, Office of Command Surgeon
U.S. Army FORSCOM
Fort McPherson, GA 30330-6000
Deputy Surgeon/Chief, PLOT: COL Raymond T. Keith
ATTN: AFMD
C: 404-669-7355; DSN: 367-7355
keithr@ftmcpnsn-emh1.army.mil
Aeromedical Evacuation/Medical Operations Officer: MAJ(P) Carl G. Jacka
ATTN: AFMD
C: 404-669-7375; DSN: 367-7375
jackac@ftmcpnsn-emh1.army.mil

Aviation Division, Directorate of Operations, DCSOPS, FORSCOM
1777 Hardee Avenue SW
Fort McPherson, GA 30330-1062



Chief:
COL Thomas M. Hayes
ATTN: AFOP-AV
C: 404-464-6085
DSN: 367-6085
hayesthomas@forscom.army.mil

Air Traffic Control Specialist: Mr. Martin B. Hammell
ATTN: AFOP-AV
C: 404-464-6047; DSN: 367-6047
hammellb@formscom.army.mil
Chief, Arms TM 1: LTC Joseph Bosst
C: 404-464-6047; DSN: 367-6047
bosstj@forscom.army.mil
Operations Officer: MAJ Larry Rood
ATTN: AFOP-AV
C: 404-464-5076; DSN: 367-5076
roodl@forscom.army.mil
USAR Aviation Coordinator Arms TM3: LTC Greg Bailey
ATTN: AFOP-AV
C: 404-464-5087; DSN: 367-5087
baileyg@forscom.army.mil
ARNG Aviation Coordinator Arms TM3: LTC John Wells
ATTN: AFOP-AV
C: 404-464-6055; DSN: 367-6055
wellsj@forscom.army.mil

Aviation Division, ODCSOPS, USARC
1401 Deshler St. SW
Fl. McPherson, GA 30330



Chief:
LTC Charles O. Koons
ATTN: AFRC-OPA
C: 404-464-8314
DSN: 404-367-8314
koonscha@usarc-emh2.army.mil

Hunter Army Airfield

224th Military Intelligence Battalion (Aerial Exploitation)
357 S. Lightning Rd., Ste. 101
Hunter Army Airfield, GA 31409-5628



Commander:
LTC Richard G. Leyden
ATTN: AFZA-MI-G-CDR
C: 912-352-6126
DSN: 971-6126
leydenr@emh5.stewart.army.mil

Executive Officer: MAJ Robert Craig Effinger
ATTN: AFZA-MI-G-XO
C: 912-352-6980; DSN: 971-6980
effinger@emh5.stewart.army.mil

SIP/MTFE: CW4 William Wary
ATTN: AFZA-MI-G-SIP
C: 912-352-6299; DSN: 971-6299
waryw@emh5.stewart.army.mil

ASO: CW5 David A. Coates
ATTN: AFZA-MI-G-ASO
C: 912-352-6399; DSN: 971-6399
coatesd@emh5.stewart.army.mil

Senior NCO: CSM Mark L. Maedgen
ATTN: AFZA-MI-G-CSM
C: 912-352-5702; DSN: 971-5702
maedgem@emh5.stewart.army.mil

3d Battalion, 160th Special Ops. Aviation Regiment (Airborne)
Hunter Army Airfield, GA 31409-5202
Commander: LTC Bruce E. Brydges
ATTN: AOAV-T-CD
C: 912-352-6645; DSN: 971-6645
brydgeb@soar.net
Executive Officer: MAJ Erik Peterson
ATTN: AOAV-T-XO
C: 912-352-6008; DSN: 971-6088
petersone@soar.net

SIP: CW3 Glenn Joyner
ATTN: AOAV-T-SIP
C: 912-352-5659; DSN: 971-5096
joynerg@soar.net

ASO: CW2 Michael Larson
ATTN: AOAV-T-OS
C: 912-352-5872; DSN: 971-5096
larsonm@soar.net

Senior NCO: CSM Michael Marquez
ATTN: AOAV-T-SM
C: 912-352-6645; DSN: 971-6645
marquezm@soar.net

B Company, 159th Aviation Regiment 18th Aviation Brigade

Hunter Army Airfield, GA 31409
Commander: MAJ William Clark Southard
ATTN: AFZP-VXN-C
C: 912-352-6665; DSN: 971-6665
SouthardW@emh5.stewart.army.mil
Executive Officer: CPT Marvin Chisholm
ATTN: AFZP-VXN-XO
C: 912-352-6526; DSN: 971-6526
ChisholmM@emh5.stewart.army.mil
SIP: CW4 Robert Miller
ATTN: AFZP-VXN-SP
C: 912-352-6762; DSN: 971-6762
MillerR2@emh5.stewart.army.mil
ASO: CW2 John Hager
ATTN: AFZP-VXN-ASO
C: 912-352-5193; DSN: 971-5193
HagerJ@emh5.stewart.army.mil
Senior NCO: 1SG MacArthur Dixon
ATTN: AFZP-VXN-1SG
C: 912-352-6514; DSN: 971-6514
DixonM@emh5.stewart.army.mil

Aviation Brigade, 3rd Infantry Div. Hunter Army Airfield, GA 31409-5100



Commander:
COL Allen S. Baker
ATTN: AFZP-VX-C
C: 912-352-6732
DSN: 971-6732
afzp-vx-c@emh5.stewart.army.mil

Executive Officer: MAJ Jessie D. Farrington
ATTN: AFZP-VX-X
C: 912-352-6983; DSN: 971-6983
FarringtonJ@emh5.stewart.army.mil
SIP: CW5 Ron Clary
ATTN: AFZP-VX-ST
C: 912-352-6535; DSN: 971-6535
afzp-vx-st@emh5.stewart.army.mil
ASO: CW5 Bradley Lupien
ATTN: AFZP-VX-SA
C: 912-352-5940; DSN: 971-5940
afzp-vx-sa@emh5.stewart.army.mil
MTFE: CW4 Michael R. Sherman
ATTN: AFZP-VX-L
C: 912-352-5529; DSN: 971-5529
afzp-vx-l@emh5.stewart.army.mil



Senior NCO:
CSM Buford Prevatte
ATTN: AFZP-VX-CSM
C: 912-352-6132
DSN: 971-6132
afzp-vx-csm@emh5.stewart.army.mil

Wyle Helps Put Army Aviation In The Air.



EMC

Safety

Climatic

Dynamic

Fatigue

Reliability

HALT/HASS

Structural Load

Test Systems

Test Planning

Failure Analysis

Munitions/Ordnance

UXO Remediation

Combined
Environments

Field Instrumentation

On-Site Technical
Support

As a leading independent testing laboratory, Wyle helps contractors put Army Aviation in the air. With five decades of Army Aviation testing experience, Wyle has qualified thousands of items covering every platform and every major contractor.

The company's nationwide laboratories and on-site support service teams specialize in dynamic, climatic, structural acoustic, hydraulic, EMC, ordnance and reliability testing and analysis, plus sophisticated NDI, metrology and health monitoring services. And, as a leader in obsolescence management, Wyle anticipates and resolves equipment availability and quality issues before they become major problems.

Wyle is the "prime tester" the U.S. Army and its prime contractors have counted on to help put aviation in the air. Contact Wyle today to see how it can handle your testing needs.

wyle
laboratories

Huntsville, Alabama. 256/837-4411 ext. 200
Norco, California. 909/737-0871 ext. 224
El Segundo, California. 310/322-1763 ext. 6640
www.wylelabs.com e-mail: service@hnt.wylelabs.com

1st Attack Helicopter Battalion, 3rd Aviation Regiment
Aviation Brigade
3rd Infantry Division (Mech)
Hunter Army Airfield, GA 31409

Commander: LTC Thomas DeVine
ATTN: AFZP-VXB-C
C: 912-352-5668; DSN: 971-5668
afzp-vxb-c@emh5.stewart.army.mil

Executive Officer: MAJ Richard Daum
ATTN: AFZP-VXB-XO
C: 912-352-6741; DSN: 971-6741
afzp-vxb-x@emh5.stewart.army.mil

SIP: CW4 Thomas Manhart
ATTN: AFZP-VXB-SIP
C: 912-352-6677; DSN: 971-6070
eggertona@emh5.stewart.army.mil

ASO: CW3 Dodd Day
ATTN: AFZP-VXB-ASO
C: 912-352-6677; DSN: 971-6677

MTFE: CW4 William S. Golorth
ATTN: AFZP-VXB-D
C: 912-352-5169; DSN: 971-5169

Senior NCO: CSM Thomas T. Watanabe
ATTN: AFZP-VXB-CSM
C: 912-352-6960; DSN: 971-6960
afzp-vxb-csm@emh5.stewart.army.mil

2d Battalion, 3d Aviation Regiment
Aviation Brigade
3d Infantry Division (Mech)
Hunter Army Airfield, GA 31409



Commander:
LTC William J. Zientek, III
ATTN: AFZP-VXE-C
C: 912-352-6190
DSN: 971-6190
zientekw@emh5.stewart.army.mil

Executive Officer: MAJ Robert Welch
ATTN: AFZP-VXE-X
C: 912-352-5107; DSN: 971-5107
welchr@emh5.stewart.army.mil

SIP: CW4 Michael Jordan
ATTN: AFZP-VXB-SIP
C: 912-352-5959; DSN: 971-5959

ASO: CW3 Perry Wilds
ATTN: AFZP-VXE-ASO
C: 912-352-6301; DSN: 971-6301

AMO: CPT Nancy Clarke
ATTN: AFZP-VXE-AMO
C: 912-352-5676; DSN: 971-5676

Senior NCO: CSM Lawrence Peoples
ATTN: AFZP-VXE-CSM
C: 912-352-5849; DSN: 971-5849

603d Aviation Support Battalion
DISCOM

3rd Infantry Division (MECH)
Hunter Army Airfield, GA 31409
Commander: LTC Donald W. Bridge
ATTN: AFZP-VSB-C
C: 912-353-2411; DSN: 971-2411
bridged@emh5.stewart.army.mil

Executive Officer: MAJ David Nelson
ATTN: AFZP-VSB-X
C: 912-353-2670; DSN: 971-2670

ASO: CW3 George A. Griffin
ATTN: AFZP-VSB-S
C: 912-353-2779; DSN: 971-2779

A Company (AVIM) Cdr.: MAJ Mark A. Smith
ATTN: AFZP-VSB-FC
C: 912-353-2781; DSN: 971-2781
Senior NCO: CSM Carlos A. Cueto
ATTN: AFZ-VSB-CSM
C: 912-353-2620; DSN: 971-2620
EM: cuetoc@emh5.stewart.army.mil

Hunter Army Airfield Garrison
Hunter Army Airfield, GA 31314

Executive Officer: Mr. Frank V. Jones
ATTN: AFZP-GC(H)
C: 912-352-5801; DSN: 971-5801
afzp-gch@stewart-emh3.army.mil

Savannah

Georgia Army National Guard Army
Aviation Support Facility #3

P. O. Box 23617
Savannah, GA 31403-3617
AASFC: MAJ Stephen E. Joyce
C: 912-352-5532; DSN: 971-5532
EM: captjuice@msn.com

CH-47ME: CW2 Jeff Hutchinson
C: 912-352-6894

CH-47 SP/IE/ASO: CW4 Jack Johnson
C: 912-352-5787

Winder

Georgia Army National Guard Army
Aviation Support Facility #1

P. O. Box 545
Winder, GA 30680-0545
AASFC: LTC Francis M. Tolle
ATTN: AASF#1
C: 770-867-6214; DSN: 338-6180

Operations Officer/UH-60: Vacant
ATTN: AASF#1
C: 770-867-6214; DSN: 338-6180

UH-60L SIP: Vacant
ATTN: AASF#1
C: 770-867-6214; DSN: 338-6180

Safety Officer/IFE: CW2 Jerry C. Baker
ATTN: AASF#1
C: 770-867-6214; DSN: 338-6180

MTP/ME: MAJ Anthony K. Sutter
ATTN: AASF#1
C: 770-867-6214; DSN: 338-6180

Windsor

148th Medical Company (AA)

Box 706
Windsor, GA 30680-0706
Commander: MAJ Anthony K. Sutter
C: 770-867-6324; DSN: 338-6180
ASO: CW4 Charles Gibson
C: 770-867-6214; DSN: 338-6180

SIP/IFE: CW2 Jerry Baker
C: 770-867-6214; DSN: 338-6180

MTFE: CW4 Max Hackney
C: 770-867-6214; DSN: 338-6180

Senior NCO: SFC Lloyd Allison
C: 770-867-6214; DSN: 338-6180

HAWAII Fort Shafter

U.S. Army Pacific (USARPAC), ODC-
SOPS Aviation Division
Fort Shafter, HI 96858-5100

Chief, Training and Aviation Division:
LTC James Coates
ATTN: APOP-TR
C: 808-438-7680; DSN: 438-7680
Chief, Aviation Branch: Mr. Fred L. McCollum
ATTN: APOP-TR-AV
C: 808-438-1081; DSN: 438-1081

Hilo

Hawaii Army National Guard Limited
Army Avn. Support Facility

1046 Leilani Street
Hilo, HI 96720-4595
AASFC: CW3 Nelson M. Kunitake
ATTN: HIARAV-SFZ
C: 808-933-0942

Honolulu

Office, State Adjutant General,
Hawaii Army National Guard
3949 Diamond Head Road
Honolulu, HI 96816-4495



TAG:
MG Edward V. Richardson
ATTN: HITAG
C: 808-733-4246
erichardson@hikang.af.mil

Schofield Barracks

G Company, 58th Aviation Regiment
(ATS)

Bldg. 102, Room 112
Schofield Barracks, HI 96857-6063
Commander: CPT Gordon D. Schmidt
ATTN: APVG-YZG-CO
C: 808-656-0996; DSN: 456-0996
cogavn@schofield-emh1.army.mil

Senior NCO: 1SG Valerie L. Faucette
ATTN: APVG-YZG-1SG
C: 808-656-5698; DSN: 456-5698
g581sq@schofield-emh1.army.mil

Wheeler Army Airfield

B Company, 214th Aviation Regiment
Wheeler Army Airfield, HI 96854-6000

Commander: CPT David Fleckenstein
C: 808-656-2005; DSN: 455-2005
Executive Officer: 1LT Paul E. Berg
C: 808-656-2005
SIP: CW4 Jeff "Elmo" Elmore
C: 808-656-2005
Senior NCO: 1SG Stephen Bolden
C: 808-656-2005

25th Infantry Division (Light) Aviation
Brigade

Wheeler Army Airfield, HI 96854-6000



Commander:
COL James A. Kelley
ATTN: APVG-YZB-CO
C: 808-656-2741
DSN: 456-2741
coavn@schofield-emh1.army.mil

Exec. Officer: MAJ Edward Kleinschmidt
ATTN: APVG-YZB-XO
C: 808-656-2740; DSN: 456-2740
xoavn@schofield-emh1.army.mil
SIP: CW5 John Sparkman
ATTN: APVG-YZB-SIP
C: 808-656-2176; DSN: 456-2176
s3avnstd@schofield-emh1.army.mil
ASO: CW4 Pete Streker
ATTN: APVG-YZB-ASO
C: 808-656-1287; DSN: 456-1287
safavn@schofield-emh1.army.mil
MTFE: CW5 Raleigh L. Voight, Jr.
ATTN: APVG-YZB-AMO
C: 808-656-2195; DSN: 456-2195
amoavn@schofield-emh1.army.mil



Senior NCO:
CSM Leon Hite Jr.
ATTN: APVG-YZB-CSM
C: 808-656-2742
DSN: 456-2742
csmavn@schofield-emh1.army.mil

C Company, 25th Aviation Rgt (AVIM)
Aviation Brigade

25th Infantry Division (Light)
Wheeler Army Airfield, HI 96854
Commander: MAJ Gregory A. Fawcett
ATTN: APVG-YZE-CO
C: 808-656-2044; DSN: 456-2044
cohc@schofield-emh1.army.mil
Senior NCO: 1SG Jerry H. McConnell
ATTN: APVG-YZE-CSM
C: 808-656-7601; DSN: 456-7601

1st Attack Helicopter Battalion,
25th Aviation Regiment

Aviation Brigade
25th Infantry Division (Light)
Wheeler Army Airfield, HI 96854-6000



Commander:
LTC Kelly J. Thomas
ATTN: APVG-YZD-CO
C: 808-656-4540
DSN: 456-4540
co125avn@schofield-emh1.army.mil

Executive Officer: MAJ Joe McClung
ATTN: APVG-YZD-XO

C: 808-656-5330; DSN: 456-5330
xo125@schofield-emh1.army.mil
SIP: CW3 Milo Hachtel
ATTN: APVG-YZD-SIP
C: 808-656-9580; DSN: 456-9580

ASO: CW4 Scott Mullins
ATTN: APVG-YZD-SO
C: 808-656-9370; DSN: 456-9370

MTP: CW3 Keith Caudill
ATTN: APVG-YZD-DCO
C: 808-656-1361; DSN: 456-1361
pl125@schofield-emh1.army.mil



Senior NCO:
CSM Sergio Villafane
ATTN: APVG-YZD-CSM
C: 808-656-5430
DSN: 456-5430
csm125av@schofield-emh1.army.mil

Zapper Plus™

Chip Detector System with BIT for H-60 Hawks

Zapper Protection Plus...

- Built-In-Test (BIT) on Start-Up
- Improved System Reliability
- Simple One-For-One Replacement
- Total Circuit Continuity Check

CHIP INPUT MDL/LH	CHIP INT. YRESH	TAIL ROTOR STOP	CHINA
CHIP ACCESS MDL/LH	CHIP INPUT MDL/SLIP		

The Zapper for H-60s
Just Got A Little BIT Better!™

*Tedeco Division

*A division of Vickers Aerospace
Marine Defense Group which includes:
Electromechanical (Rotary/Linear
Actuators...), **Fluid Power** (Hydraulic
Pumps, Motors...), and **Sterer Division**
(Valves, Manifolds, Modules...)

VICKERS

24 E. Glenolden Avenue
Glenolden, PA 19036
610-583-9400 (USA)
44-1705-487251 (UK)

**2nd Assault Helicopter Battalion,
25th Aviation Regiment
Aviation Brigade**
25th Infantry Division (Light)
Wheeler Army Airfield, HI 96854



Commander:
LTC Curtis D. Polts
ATTN: APVG-YZJ-CO
C: 808-656-0130
DSN: 456-0130
co225av@schofield-emh1.army.mil

Executive Officer: MAJ David B. Parker
ATTN: APVG-YZJ-XO
C: 808-656-2566; DSN: 456-2566
xo225av@schofield-emh1.army.mil
SIP: CW3 Perry Matthews
ATTN: APVG-YZJ-SIP
C: 808-656-2544; DSN: 456-2544
xo225av@schofield-emh1.army.mil
ASO: CW3 David Hennies
ATTN: APVG-YZJ-ASO
C: 808-656-2544; DSN: 456-2544
MTFE: CW4 Jim Wells
ATTN: APVG-YZJ-DCO-HHC
C: 808-656-2533; DSN: 456-2550



Senior NCO:
CSM Rafael Castro
ATTN: APVG-YZJ-
CSM
C: 808-656-0330
DSN: 456-0330
csm25av@schofield-emh1.army.mil

**3rd Squadron (Recon), 4th U.S.
Cavalry
Aviation Brigade**
25th Infantry Division (Light)
Wheeler Army Airfield, HI 96854
Commander: LTC Walter M. Golden Jr.
ATTN: APVG-YZF-CO
C: 808-656-4060; DSN: 455-4060
EM: cocav@schofield-emh1.army.mil
Executive Officer: MAJ Richard B. White
ATTN: APVG-YZF-XO
C: 808-656-5450; DSN: 455-5450
xocav@schofield-emh1.army.mil
SIP: CW4 Scott M. Paulson
ATTN: APVG-YZF-SIP
C: 808-656-1147; DSN: 455-1147
safycav@schofield-emh1.army.mil
ASO: CW3 Mark A. Martin
ATTN: APVG-YZF-ASO
C: 808-656-1147; DSN: 455-1147
safycav@schofield-emh1.army.mil



Senior NCO:
CSM Charles M. Richardson
ATTN: APVG-YZF-
CSM
C: 808-656-5550
DSN: 455-5550
csmcav@schofield-emh1.army.mil

**Office, State Army Aviation Officer,
Hawaii Army National Guard**
Building 829
Wheeler Army Airfield, HI 96854-5110

SAAO: COL Orian L. Peterson, Jr.
ATTN: HIARAV
C: 808-656-2716
saohi@hi-armg.ngb.army.mil

**Hawaii Army National Guard Army
Aviation Support Facility #1**
Building 829
Wheeler Army Airfield, HI 96854-5110
AASFC: LTC Gary M. Hara
ATTN: HIARAV-SF1
C: 808-656-2709
haragm@hi-armg.ngb.army.mil

IDAHO Boise

**Office, State Adjutant General, Idaho
Army National Guard**
4040 W. Guard Street
Boise, ID 83705-5004



TAG:
MG John F. Kane
ATTN: IDCG
C: 208-422-5225
DSN: 422-5225
jkane@idbol.ang.af.mil

**Office, State Army Aviation Officer,
Idaho Army National Guard**
3315 Aeronca
Building 1500
Boise, ID 83705-8008
SAAO: COL Michael A. Smith
ATTN: DOAV-Z
C: 208-422-3972; DSN: 422-3972
saoid@id-armg.ngb.army.mil

**Idaho Army National Guard Army
Aviation Support Facility**
3315 Aeronca
Building 1500
Boise, ID 83705-5004
AASFC: COL Michael A. Smith
ATTN: IDAV-Z
C: 208-422-5273; DSN: 422-5273
aasf1id@id-ngnet.army.mil

ILLINOIS Chicago

**Illinois Army National Guard Army
Aviation Support Facility #2**
5400 West 63rd Street
Chicago, IL 60638-5690
AASFC: MAJ Kurt Kennard
C: 312-735-7825; DSN: 735-7825

Decatur

**Illinois Army National Guard Army
Aviation Support Facility #1**
660 Airport Road
Decatur, IL 62521-8710
AASFC: COL Michael Marvin
ATTN: AASF#1
C: 217-422-3687; DSN: 555-3618
daasf-1@il-armg.ngb.army.mil

Fort Sheridan

244th Aviation Brigade
3155 Blackhawk Drive
Suite 563
Fort Sheridan, IL 60037-5000



Commander:
COL Daniel J. McGraw
ATTN: AFRC-AVIL-CO
C: 920-727-7421
dmcgraw@jkkeller.com



Senior NCO:
CSM Simpson
ATTN: AFRC-AVIL-CSM
C: 847-329-9180

Peoria

**Illinois Army National Guard Army
Aviation Support Facility #3**
2323 South Airport Road
Peoria, IL 61607-1497
AASFC: MAJ Dean Espenschied
C: 309-697-7900; DSN: 724-4040

Springfield

**Office, State Adjutant General,
Illinois Army National Guard**
1301 N. MacArthur Boulevard
Springfield, IL 62702-2399
TAG: BG Richard G. Austin
C: 217-785-3500; DSN: 555-3500

**Office, State Army Aviation Officer,
Illinois Army National Guard
Office, The Adjutant General**
Camp Lincoln
1301 N. MacArthur Boulevard
Springfield, IL 62702-2399



SAAO:
COL Ronald I. Botz
ATTN: DMAIL-SA
C: 217-761-3570
DSN: 555-3570
saoil@il-armg.ngb.army.mil

INDIANA Indianapolis

**Office, State Adjutant General,
Indiana Army National Guard**
2002 South Holt Road
Indianapolis, IN 46241-4839
TAG: MG Robert J. Mitchell
ATTN: MDI-AG
C: 317-247-3279; DSN: 369-2279
tagin@in-ngnet.army.mil

**Office, State Army Aviation Officer,
Indiana Army National Guard
Military Dept. of Indiana
Director of Army Aviation**
2002 South Holt Road
Indianapolis, IN 46241-4839
SAAO: MAJ Jim Dunn
ATTN: MDI-AA
C: 317-247-3548; DSN: 369-2548
saoin@in-armg.ngb.army.mil

Shelbyville

681st Medical Co. (Air Ambulance)
3556 N. Michigan Road
Shelbyville, IN 46176-9414

**Indiana Army National Guard Army
Aviation Support Facility**
3556 N. Michigan Road
Shelbyville, IN 46176-9414
AASFC: MAJ Pamela P. Johnson
ATTN: MDI-AASF
C: 317-392-8202; DSN: 366-2202
johnsonpp@in-armg.ngb.army.mil

IOWA Boone

**1st Battalion, 109th Aviation
Regiment (AVIM)**
Iowa Army National Guard
700 Snedden Drive
Boone, IA 50036
Commander: LTC Robert J. Felderman
C: 515-252-4843
EM: staeblem@ia-armg.ngb.army.mil
Senior NCO: CSM Bob Heaps
C: 515-252-4843

**Iowa Army National Guard Aviation
Support Facility #1**
700 Corporal Roger Snedden Dr.
Boone, IA 50036-5411
AASFC: MAJ Russell E. Perry
ATTN: AASF-BNW
C: 515-432-6351; DSN: 946-2862

Davenport

**Iowa Army National Guard Army
Aviation Support Facility #3**
9650 Harrison Street
Davenport, IA 52804-9803
AASFC: LTC Eddie L. Newman
C: 319-391-3635; DSN: 493-4733

Johnstown

**Office, State Adjutant General, Iowa
Army National Guard**
7700 N.W. Beaver Drive
Johnstown, IA 50131-1902



TAG:
MG Warren G. Lawson
ATTN: AGIA-Z
C: 515-252-4211
DSN: 946-2211
tag@ia-ngnet.army.mil

**Office, State Army Aviation Officer,
Iowa Army National Guard
The Adjutant General of Iowa**
Camp Dodge
7700 N.W. Beaver Drive
Johnstown, IA 50131-1902



SAAO:
COL Lyle D. Bender
ATTN: DIRAAVN
C: 515-252-4376
DSN: 946-2376

When your cockpit displays
call for reinforcements,
go in with a full backup unit.



The GH-3000 Electronic Standby Instrument System

Why settle for a single-function standby indicator when you can upgrade to a full backup solid-state suite in the same 3AT1 panel space? That's the advantage of the new GH-3000 electronic standby from BFGoodrich. No single unit in military aviation offers so much backup protection in such a compact all-in-one display.

Combining all the basic flight cues — attitude, indicated airspeed, altitude, slip, mach number, Vmo/Mmo, heading and navigation — the GH-3000 saves cost, workload and panel space by replacing multiple standby instruments with a single 3-inch unit. Now you can have a complete standby EFIS in one easy-to-read AMLCD display.

Designed for rugged military environments, the GH-3000 is made in the USA and is FAA TSO-certified, conforming to RTCA DO-178B software certification criteria. The display can be fitted to meet MIL-L-85762A specs for night vision goggle compatibility. This commercial, off-the-shelf unit retrofits easily in existing panels, and its high sensing rate can handle highly dynamic maneuvers. The BFG GH-3000: It's the full backup unit your outfit needs to keep moving forward. For more information, contact your BFG Avionics Military Sales team at 1-800-253-9525.

5353 52nd Street, S.E. • P.O. Box 873 • Grand Rapids, MI, USA 49588-0873
Telephone: (616) 949-6600 • Fax: (616) 285-4224 • Website: www.bfgavionics.com

©1998 BFGoodrich Avionics Systems, Inc.

BFGoodrich
Aerospace

Avionics Systems

Waterloo

Iowa Army National Guard Army
Aviation Support Facility #2
2245 West Big Rock Road
Waterloo, IA 50703-9645
AASFC: MAJ Walter M. Salmon
C: 319-234-1372; DSN: 946-2387

KANSAS Fort Leavenworth

Det. B, Co C, 2-228th Avn Regt
Sherman Army Airfield
Fort Leavenworth, KS 66027-5071
Commander: 1LT Robert W. Todd
ATTN: ANAV-WRK
C: 913-684-6020; DSN: 552-6020

Fort Riley

Command Aviation Flight
Detachment
Fort Riley, KS 66442
Commander: CPT Jay D. Offenberger
ATTN: AFZN-EN-VAV
C: 785-239-3339; DSN: 856-3339
offenbej@riley-emh1.army.mil

New Century

Aviation Support Facility Olathe
21 Gardner Drive
New Century, KS 66301-0020
Facility Supervisor: Mr. Michael D. Walsh
C: 913-782-1077; DSN: 552-7670
mw Walsh4061@aol.com

Salina

Kansas Army National Guard Army
Aviation Support Facility #2
2917 Hein Street
Salina, KS 67401-8146
Commander: CPT David A. Leger
C: 785-822-3451; DSN: 72-3451

Topeka

1st Battalion, 108th Aviation
Regiment (Assault)
P. O. Box 19086
Forbes Field
Topeka, KS 66619-0086
Commander: LTC Walter H. Frederick III
C: 785-862-0774
wfredrick@aol.com
Executive Officer: MAJ Victor J. Braden
C: 785-862-0774
vbraden1@aol.com
S-3: MAJ Alan K. Soldan
C: 785-862-0774
asoldan1@aol.com
SIP: CW4 Robert Good
C: 785-274-1727; DSN: 720-8717
Safety Officer: CW4 Tony Shultz
C: 785-274-1714
EM: ashultzaso@aol.com
Senior NCO: CSM Alan J. Mueting
C: 785-274-1065; DSN: 720-8065

Office, State Adjutant General,
Kansas Army National Guard
2800 S.W. Topeka Boulevard
Topeka, KS 66611-1287



TAG:
MG James F. Rueger
ATTN: TAG-KS
C: 913-274-1001
DSN: 720-8001
tagks@amgrc-emh2.army.mil

Commander: LTC Charles H. Morrow
C: 913-274-1056; DSN: 720-4695

Office, State Army Aviation Officer,
Kansas Army National Guard
2722 S.W. Topeka Blvd., P.O. Box 19061
Topeka, KS 66619-0061
SAAO: COL Floyd "Dennis" Parry
ATTN: AGKS-AVN
C: 913-274-1701; DSN: 720-8701
saoks@ks-amg.ngb.army.mil

Kansas Army National Guard Army
Aviation Support Facility #1
P. O. Box 19061
Topeka, KS 66619-0061
Commander: COL Floyd "Dennis" Parry
C: 785-274-1701; FSN: 720-8701

KENTUCKY Fort Campbell

160th Special Operations Aviation
Regiment (Airborne)
Fort Campbell, KY 42223-5000



Commander:
COL Howard W.
Yellen
ATTN: AOAV-CD
C: 502-798-1360
DSN: 635-1360
yellenh@soar.net

Deputy Commander: COL Richard B.
Bowman
ATTN: AOAV-DC
C: 502-798-1360; DSN: 635-1360
bowmanr@soar.net

Executive Officer: LTC Richard N.
DiGiovanni
ATTN: AOAV-XO
C: 502-798-1360; DSN: 635-1360
digiovannir@soar.net

SIP: CW5 Randy Jones
ATTN: AOAV-SC
C: 502-798-1761; DSN: 635-1761
jonesr@soar.net

ASO: CW5 John H. Aberg
ATTN: AOAV-OS
C: 502-798-1938; DSN: 635-1938
abergj@soar.net

Maintenance Officer: CW5 Walter E.
Riley
ATTN: AOAV-SI
C: 502-798-1966; DSN: 635-1966
rileyw@soar.net

SOATC Commander: LTC William
Harrison

ATTN: AOAV-ST
C: 502-798-1729; DSN: 635-1729
harrisonw@soar.net

Systems Integration Management:
LTC George Kunkel
ATTN: AOAV-SM
C: 502-798-1830; DSN: 635-1830
kunkelg@soar.net



Senior NCO:
CSM Clifton P. O'Brien
ATTN: AOAV-SM
C: 502-798-1616
DSN: 635-1616
obrienc@soar.net

1st Battalion, 160th Special Opns.
Aviation Regiment (Airborne)

Fort Campbell, KY 42223-5000
Commander: LTC Michael Zonfrelli
ATTN: AOAV-F-CD
C: 502-798-1585; DSN: 635-1585
zonfrellim@soar.net

Executive Officer: MAJ(P) Emmett C.
Shaffer
ATTN: AOAV-F-XO
C: 502-798-1305; DSN: 635-1305
shaffere@soar.net

ASO: CW3 Troy Boonstra
ATTN: AOAV-F-OS
C: 502-798-1308; DSN: 635-1308
boonstrat@soar.net

Command Sergeant Major: CSM
Donnie Calvery
ATTN: AOAV-F-SM
C: 502-798-1307; DSN: 635-1307
calveryd@soar.net

2d Battalion, 160th Special Opns.
Aviation Regiment (Airborne)
Fort Campbell, KY 42223-5000



Commander:
LTC Andrew N. Milani II
ATTN: AOAV-S-SC
C: 502-798-1569
DSN: 635-1569
milania@soar.net

Executive Officer: MAJ Keith Kodalen
ATTN: AOAV-S-XO
C: 502-798-1576; DSN: 635-1576
kodalenk@soar.net

ASO: CW4 John E. Albers
ATTN: AOAV-S-OS
C: 502-798-1553; DSN: 635-1553
albersj@soar.net



Command Sergeant
Major:
CSM Michael J.
Morris
ATTN: AOAV-S-SM
C: 502-798-1577
DSN: 635-1577
morrismi@soar.net

4th Battalion, 160th Special
Operations Aviation Regiment
(Airborne)

Fort Campbell, KY 42223-5000
Commander: LTC Michael Taliento
ATTN: AOAV-Z-CD
C: 502-956-3705; DSN: 363-3705
talientom@soar.net

Executive Officer: MAJ Joseph Hicks
C: 502-798-1921; DSN: 635-1921
hicksj@soar.net

ASO: CW3 Steven Frey
ATTN: AOAV-S-SC
C: 502-798-3701; DSN: 363-3701
frey@ssoar.net
Senior NCO: CSM Raymond Owen
C: 502-798-1927; DSN: 635-1927
owenr@ssoar.net

101st Airborne Division (Air Assault)
Fort Campbell, KY 42223-5627

Commanding General: MG Robert T.
Clark
ATTN: AFZB-CG
C: 502-798-9915; DSN: 635-9915
clarkr@campbell-emh5.army.mil

Assistant Division Commander
(Support): BG Virgil L. Packett, II
ATTN: AFZB-DC-S
C: 502-798-9514; DSN: 635-9514
packettv@campbell-emh5.army.mil
Senior NCO: CSM Gerard J. Counts
ATTN: AFZB-CSM
C: 502-798-9145; DSN: 635-9145
countsg@campbell-emh5.army.mil

Division Support Command (DISCOM)

101st Abn. Div. (Air Assault)
Fort Campbell, KY 42223-5000
Commander: COL L. Clay
ATTN: AFZB-KE-CO
C: 502-798-6749; DSN: 635-6749

8th Battalion, 101st Aviation Regiment
Division Support Command
101st Airborne Div. (AASLT)
Fort Campbell, KY 42223

Commander: LTC Marc P. Brodeur
ATTN: AFZB-KE-K
C: 502-798-6443; DSN: 635-6443
Executive Officer: MAJ Alan M. Stull
ATTN: AFZB-KE-K
C: 502-798-2026; DSN: 635-2026
MTFE: CW5 Joe N. Meyers
ATTN: AFZB-KE-AM
C: 502-798-6226; DSN: 635-6226
Senior NCO: CSM Edward C. Roberts
ATTN: AFZB-KE-K
C: 502-798-2026; DSN: 635-2026

50th Medical Company (Air Ambulance)
Fort Campbell, KY 42223-5000

Commander: MAJ Glenn T. Iacovetta
ATTN: AFZB-KE-K-AA
C: 502-798-7267; DSN: 635-7267
afzb-ke-aa@campbell-emh1.army.mil

101st Airborne Division (AASLT)
Aviation Brigade

Fort Campbell, KY 42223
Commander: COL Samuel J. Hubbard, Jr.
ATTN: AFZB-KF-CO
C: 502-956-3482
DSN: 363-3482
hubbards@emh2.campbell-emh2.
army.mil

Executive Officer: MAJ W. Thomas Rice
ATTN: AFZB-KF-XO
C: 502-956-3522; DSN: 363-8522
ricew@emh2.campbell.army.mil

SIP: CW5 Jack Bartel
ATTN: AFZB-KF-SIP
C: 502-798-6781; DSN: 635-6781
ASO: CW4 Ron Rittler
ATTN: AFZB-KF-ASO
C: 502-798-5707; DSN: 635-5707

The Next Generation of Army Tactical UAVs



Prowler II™ Tactical UAV was designed to meet the operational needs of the Army both today and tomorrow.

- Combat-Proven Technology
- Operations From Semi-Prepared Surfaces
- Heavy Fuel Engine
- Small Logistic Footprint for Operations by Forward-Deployed Maneuver Forces
- EO/IR or SAR Payload
- Highly Mobile
- >20 Hour Endurance Provides Maximum Mission Flexibility



**Designed to be Operated
by Army Technicians
for the Army**

General Atomics Aeronautical Systems, Inc.
16761 Via Del Campo Court • San Diego, CA 92127 • (619) 455-2810

MTFE: CW4 Ray E. Jackson
ATTN: AFZB-KF-PC
C: 502-798-5222; DSN: 635-5222
Senior NCO: CSM William Langston
ATTN: AFZB-KF-CSM
C: 502-956-3441; DSN: 363-3441

**1st Battalion, 101st Aviation Regt
101st Aviation Brigade (ATK)
101st Airborne Div. (AA)**
101st Airborne Div. (AA)
Fort Campbell, KY 42223

Commander: LTC D. Mark Ferrell
ATTN: AFZB-KF-E-CO
C: 502-798-4638; DSN: 635-4638
ferrellm@campbell-emh5.army.mil
Executive Officer: MAJ Mike Barbee
ATTN: AFZB-KF-E-XO
C: 502-798-4638; DSN: 635-4638
barbeem@campbell-emh5.army.mil
SIP (AH-64): CW4 Duane Crawford
ATTN: AFZB-KF-E-S
C: 502-798-2750; DSN: 635-2750
crawfordd@campbell-emh5.army.mil
ASO: CW3 Garry Lambert
ATTN: AFZB-KF-E-S
C: 502-798-2745; DSN: 635-2745
lambertg@campbell-emh5.army.mil
Senior NCO: CSM Daniel Mace
AFZB-KF-E-CSM
C: 502-798-5776; DSN: 635-5776
maced@campbell-emh5.army.mil

**2d Battalion, 101st Aviation Regt
Aviation Brigade
101st Airborne Div. (AASLT)**
Fort Campbell, KY 42223-5742



Commander:
LTC Greg Gass
ATTN: AFZB-KF-M-CO
C: 502-798-3070
DSN: 635-3070
gassg@emh2.
campbell.army.mil

Executive Officer: MAJ John A. Larsen
ATTN: AFZB-KF-M-XO
C: 502-798-4839; DSN: 635-4839
larsenj@campbell-emh5.army.mil
SIP: CW4 Jeff Wineland
ATTN: AFZB-KF-M-SIP
C: 502-798-2494; DSN: 635-2494
ASO: CW4 Timothy Roderick
ATTN: AFZB-KF-M-ASO
C: 502-798-2494; DSN: 635-3759
MTFE: CW3 Glenn Carthron
ATTN: AFZB-KF-M-MTFE
C: 502-798-3644; DSN: 635-3644



Senior NCO:
CSM Anthony Santos
ATTN: AFZB-KF-M-
CSM
C: 502-798-3494
DSN: 635-3494

**2d Squadron, 17th Cavalry
Aviation Brigade
101st Airborne Div. (AASLT)**
Fort Campbell, KY 42223-6015
Commander: LTC James C. McConville
ATTN: AFZB-KF-K-CO
C: 502-798-7742; DSN: 635-7742
mcconvillej@campbell-emh5.army.mil
Executive Officer: MAJ Eric Johnson
ATTN: AFZB-KF-K-XO
C: 502-798-7742; DSN: 635-7742

SIP: CW3 Robert L. Huffman
ATTN: AFZB-KF-K-T
C: 502-798-7472; DSN: 635-7472
ASO: CW3 Daniel R. Haut
ATTN: AFZB-KF-K-AS
C: 502-798-7472; DSN: 635-7472
AMO: CPT Billy Watts, Jr.
ATTN: AFZB-KF-K-I
C: 502-798-3657; DSN: 635-3657
Senior NCO: CSM Ricky E. Terrell
ATTN: AFZB-KF-K-CSM
C: 502-798-7300; DSN: 635-7300

**3d Battalion, 101st Aviation Regiment
Aviation Brigade
101st Airborne Div. (AA)**
Fort Campbell, KY 42223

Commander: LTC Wilfred F. Brown
ATTN: AFZB-KF-F-CO
C: 502-798-4019; DSN: 635-4019
Brownw@campbell-emh5.army.mil
Executive Officer: MAJ David L.
Wilson
ATTN: AFZB-KF-F-XO
C: 502-798-5446; DSN: 635-5446
SIP: CW4 Frank T. Ferraiuolo
ATTN: AFZB-KF-F-SIP
C: 502-798-9073; DSN: 635-9073
FerraiuoloF@campbell-emh5.army.mil
ASO: CW3 Bobby Schweikort
ATTN: AFZB-KF-F-ASO
C: 502-798-9384; DSN: 635-9384
schweikartb@campbell-emh5.army.mil
MTFE: CW3 Tony A. Hines
ATTN: AFZB-KF-F-MTFE
C: 502-798-9219; DSN: 635-9219
Senior NCO: CSM Russel W. Sadler
ATTN: AFZB-KF-F-CSM
C: 502-798-4019; DSN: 635-4019

**4th Battalion, 101st Aviation Regt
159th Aviation Brigade
101st Airborne Division (AA)**
Fort Campbell, KY 42223



Commander:
LTC James E.
Moentmann
ATTN: AFZB-KM-E
C: 502-798-4015
DSN: 635-4015
moentmannj@camp-
bell-emh5.army.mil

Executive Officer: MAJ Paul Bricker
ATTN: AFZB-KM-E
C: 502-798-4015; DSN: 635-4015
brickerp@campbell-emh5.army.mil
SIP: CW4 Greg Goodall
ATTN: AFZB-KM-E
C: 502-798-4015; DSN: 635-4015
goodallg@campbell-emh5.army.mil
ASO: CW3 Leon Harwood
ATTN: AFZB-KM-E
C: 502-798-5951; DSN: 635-5951
harwoodl@campbell-emh5.army.mil
MTFE: CW4 William Frazier
ATTN: AFZB-KM-E
C: 502-798-5779; DSN: 635-5779
frazierw@campbell-emh5.army.mil



Senior NCO:
CSM Gregory McAnn
ATTN: AFZB-KM-E
C: 502-956-4039
DSN: 363-4039
mccannng@campbell-
emh5.army.mil

**5th Battalion, 101st Aviation
Regiment
159th Aviation Brigade
101st Airborne Div. (AA)**
Fort Campbell, KY 42223-5000



Commander:
LTC Robert W.
Kenneally, Jr.
ATTN: AFZB-KM-F
C: 502-798-0216
DSN: 635-0216
kenneallyr@-emh2.
campbell.army.mil

Executive Officer: MAJ George W.
Benter, IV
ATTN: AFZB-KM-F
C: 502-798-0211; DSN: 635-0211
benterg@emh2.campbell.army.mil
SIP: CW4 William Van Almsick
ATTN: AFZB-KM-F
C: 502-798-3147; DSN: 635-3147
vanalmsicw@emh2.campbell.army.mil

ASO: CW3(P) Stanley J. Buck
ATTN: AFZB-KM-F
C: 502-798-3147; DSN: 635-3147
bucks@emh2.campbell.army.mil
MTFE: CW3 Richard Schillo
ATTN: AFZB-KM-F
C: 502-798-4451; DSN: 635-4451
schillor@emh2.campbell.army.mil



Senior NCO:
CSM Gregory Howard
ATTN: AFZB-KM-F
C: 502-798-0213
DSN: 635-0213
howardg@emh2.
campbell.army.mil

**6th Battalion, 101st Aviation
Regiment
Aviation Brigade
101st Airborne Div. (AA)**
Fort Campbell, KY 42223
Commander: LTC Anne F. MacDonald
ATTN: AFZB-KF-I
C: 502-798-2574; DSN: 635-2574
macdonalda@campbell-emh5.
army.mil

Executive Officer: MAJ Stephen T.
Houston
ATTN: AFZB-KF-I
C: 502-798-3965; DSN: 635-3965
houstons@campbell-emh5.army.mil
SIP: CW4 Michael R. Smith
ATTN: AFZB-KF-I
C: 502-798-2509; DSN: 635-2509
smithm@campbell-emh5.army.mil
ASO: CW3 Daniel Skogen
ATTN: AFZB-KF-I
C: 502-798-2509; DSN: 635-2509
skogend@campbell-emh5.army.mil
MTFE: CW4 Byron K. Dozier
ATTN: AFZB-KF-I
C: 502-798-2954; DSN: 635-2954
Senior NCO: CSM Frank A. Prather
ATTN: AFZB-KF-I
C: 502-798-3960; DSN: 635-3960

**7th Battalion, 101st Aviation
Regiment
159th Aviation Brigade
101st Airborne Div. (AASLT)**
Fort Campbell, KY 42223



Commander: LTC
Richard L. Polczynski
ATTN: AFZB-KF-J-CO
C: 502-798-5717;
DSN: 635-5717
polczynskir@camp-
bell-emh1.army.mil

Executive Officer: MAJ David Palmer
ATTN: AFZB-KF-J-XO
C: 502-798-5717; DSN: 635-5717
afzb-kf-j-xo@campbell-emh1.army.mil
SIP: CW5 John E. Sims
ATTN: AFZB-KF-J-SIP
C: 502-798-5761; DSN: 635-5761
ASO: CW4 Timothy K. Welsh
ATTN: AFZB-KF-J-ASO
C: 502-798-5761; DSN: 635-5761
BAMO: CW4 Lester F. Dehr III
ATTN: AFZB-KF-J-BAMO
C: 502-798-5502; DSN: 635-5502
Senior NCO: CSM James O. Jackson
ATTN: AFZB-KF-J-CSM
C: 502-798-5717; DSN: 635-5717
afzb-kf-j@campbell-emh1.army.mil

**9th Battalion, 101st Aviation
Regiment
159th Aviation Brigade
101st Airborne Division (AA)**
Fort Campbell, KY 42223



Commander:
LTC Steve Briggs
ATTN: AFZB-KM-
H.CO
C: 502-956-3792
DSN: 363-3792
briggss@emh2.
campbell.army.mil

Executive Officer: MAJ Laura
Richardson
ATTN: AFZB-KM-H-XO
C: 502-956-3797; DSN: 363-3797
richardsol@campbell-emh5.army.mil
SIP: CW4 Brent C. Driggers
ATTN: AFZB-KM_H_FS
C: 502-798-4968; DSN: 635-4968
driggersb@campbell-emh5.army.mil
ASO: CW3 Gary Graham
ATTN: AFZB-KM-H-ASO
C: 502-798-4957; DSN: 635-4957
MTP: CPT Michelle Bailey
ATTN: AFZB-KM-H-C
C: 502-798-5405; DSN: 635-5405
Senior NCO: CSM Keith C. Klaehn
ATTN: AFZB-KM-H-CSM
C: 502-956-3808; DSN: 363-3808
klaehnk@campbell-emh5.army.mil

159th Aviation Brigade (Assault)
Building 7159
Fort Campbell, KY 42223
Commander: COL Timothy P. McHale
ATTN: AFZB-KM-CO
C: 502-956-3048; DSN: 363-3048
mchalet@campbell-emh2.army.mil
Executive Officer: MAJ James J. Lauer
ATTN: AFZB-KM-XO
C: 502-956-3047; DSN: 363-3047
lauerj@campbell-emh2.army.mil
SIP: CW5 Micheal Hutson
ATTN: AFZB-KM-STD
C: 502-798-2029; DSN: 365-2029
hutsonm@campbell-emh2.army.mil
ASO: CW4 Timothy Welsh
ATTN: AFZB-KM-AS
C: 502-798-5222; DSN: 635-5222
welshl@campbell-emh2.army.mil



We know where you're coming from and we'll help you wherever you're going.

Pentagon Federal Credit Union has been helping military personnel and their families with all their household finances for more than 60 years. As one of the strongest and safest credit unions serving the Army, Air Force, and DoD, we understand the unique responsibilities you shoulder. That's why all our products and services are specially designed to give you the greatest value for your future, and the most convenience for your lifestyle.

No matter where in the world you're stationed, you can access your accounts and conduct transactions 24 hours a day. We provide special "predeployment kits" to help you cover all the aspects of your family's finances before you go TDY at a moment's notice or for an uncertain amount of time. We offer low-rate emergency loans for the unexpected, flexible checking accounts, and high-yield certificates and savings plans for your every day needs. And we don't gouge you with high fees or nickel-and-dime you to death like the big banks do.

As a member of Pentagon Federal Credit Union you're part of a family. A family that understands what you're going through and what you need. A family that cares about your family and about you.

So visit a branch, check us out on the Internet or call today to see how Pentagon Federal can help you take care of what's important to you. Please mention code 6AA.

1-800-247-5626 or (703) 683-7787
www.PenFed.org.



© 1998 PFCU

NCUA

Pentagon Federal is one of the largest and safest credit unions serving Army, Air Force and DoD personnel; active duty, reserves, National Guard and veterans. All Army and Air Force Officers are eligible for membership. Enlisted or civilian employees of the Army, Air Force or DoD who are not eligible to join another credit union are also eligible. Members of certain military associations can join. If you are a retiree or a relative of the above - you may be eligible as well. Call today and we'll help you find out if you're eligible to join. You must be a member to receive services.



**Pentagon Federal
Credit Union**

Distinguished Members. Proven Service.®

Fort Knox

**1st Aviation Training Battalion
"WarHawks"**
3d Regional Training Brigade
Fort Knox, KY 40121-5000



Commander:
LTC Ben H. Williams, III
ATTN: AFKA-BAK-AV-
CDR
C: 502-624-7542
DSN: 464-7542
williamsb@ftknox-
emh9-army.mil

Executive Officer: MAJ Scott W.
Hollingsworth
ATTN: AFKA-BAK-AV-XO
C: 502-624-4723; DSN: 464-4723
hollings@ftknox-emh9.army.mil

Operations Officer: MAJ Rick Bedwell
ATTN: AFKA-BAK-AV-S3
C: 502-624-8445; DSN: 464-8445
bedwellr@ftknox-emh9.army.mil

ASO: CW4 Larry C. Bugg
ATTN: AFKA-BAK-AV-ASO
C: 502-624-7232; DSN: 464-7232
buggl@ftknox-emh9.army.mil

Senior NCO: SGM Caleb Barr III
ATTN: AFKA-BAK-AV-SGM
C: 502-624-7789; DSN: 464-7789
barro@ftknox-emh9.army.mil

8th Battalion, 229th Aviation Regiment (Attack)

Fort Knox, KY 40121-5000
Commander: MAJ John E. Valentine
ATTN: AFRC-AVIL-BQ-CO
C: 502-624-3069; DSN: 464-3069
valentinej@ftknox-emh3.army.mil

Executive Officer: MAJ Michael J. Currie
ATTN: AFRC-AVIL-BQ-XO
C: 502-624-2970; DSN: 464-2970
curriem@ftknox-emh3.army.mil

S-2: 1LT Timothy S. Rogers
ATTN: AFRC-AVIL-BQ-IN
C: 502-624-7913; DSN: 464-7913
rogerst@ftknox-emh3.army.mil

S-3: MAJ Kenneth A. Cerney
ATTN: AFRC-AVIL-BQ-OP
C: 502-624-2271; DSN: 464-2271
cerneyk@ftknox-emh3.army.mil

S-4: CPT Robert E. Mann
ATTN: AFRC-AVIL-BQ-LG
C: 502-624-6644; DSN: 464-6644
mannr@ftknox-emh3.army.mil

Safety Officer: CW3 Jeffrey L. Eickholt
ATTN: AFRC-AVIL-BQ-SA
C: 502-624-4269; DSN: 464-4269
eickhljt@ftknox-emh3.army.mil

Senior NCO: CSM James H. Robinson
ATTN: AFRC-AVIL-BQ-CM
C: 502-624-3794; DSN: 464-3794
HHC Commander: CPT Christopher A.
Armbrust

ATTN: AFRC-AVIL-BQ-T
C: 502-624-2715; DSN: 464-2715
armbrustc@ftknox-emh3.army.mil

Company A Commander: CPT Earl G.
Williams
ATTN: AFRC-AVIL-BQ-BA
C: 502-624-3142; DSN: 464-3142
williams@ftknox-emh3.army.mil

Company B Commander: CPT Robert
J. Antolick
ATTN: AFRC-AVIL-BQ-BB
C: 502-624-2425; DSN: 464-2425
antolickr@ftknox-emh3.army.mil

Company C Commander: CPT James
O. Posey

ATTN: AFRC-AVIL-BQ-BC
C: 502-624-3343; DSN: 464-3343
poseyj@ftknox-emh3.army.mil

Company D Commander: CPT Martin
J. Tower
ATTN: AFRC-AVIL-BQ-BD
C: 502-624-3008; DSN: 464-3008
towerm@ftknox-emh3.army.mil

Aviation Support Facility Knox

Fort Knox, KY 40121-5000
Facility Supervisor: Mr. Guy A. Garica
ATTN: AFKB-AC-AV
C: 502-624-4877; DSN: 464-4877

U.S. Army Armor Center

Fort Knox, KY 40121-5000

Frankfort

63rd Aviation Group

100 Minuteman Drive
Boone National Guard Center
Frankfort, KY 40601

Commander: COL Robert L. Stephens
ATTN: KG-63-AV
C: 502-564-8511; DSN: 366-3511

**Office, State Adjutant General,
Kentucky Army National Guard**
100 Minuteman Parkway
Frankfort, KY 40601-6168



TAG:
BG John R. Groves, Jr.
ATTN: TAG
C: 502-564-8558
DSN: 366-3558

**Office, State Army Aviation Officer,
Kentucky Army National Guard
Army Aviation Support Facility**
Boone ARNG Center, 100 Minuteman Dr.
Frankfort, KY 40601-6168

SAAO: LTC Scott Shannon
ATTN: KG-DOA
C: 502-564-8471; DSN: 366-3471
sshannon@bngc.dma.state.ky.us

**Kentucky Army National Guard Army
Aviation Support Facility**
Boone National Guard Center

100 Minuteman Parkway
Frankfort, KY 40601-6168
AASFC: LTC Scott Shannon
C: 502-564-6315; DSN: 366-6315

LOUISIANA Fort Polk

**4th Squadron, 2nd Armored Cavalry
Regiment**
Fort Polk, LA 71459



Commander:
LTC David L.
Lawrence
ATTN: AFZX-AV-SQCF
C: 318-531-7105
DSN: 863-7105
lawrend@polk-
emh2.army.mil

Executive Officer: MAJ Emory W.
Brownlee, Jr.

ATTN: AFZX-AV-XO
C: 318-531-7105; DSN: 863-7105
brownlee@polk-emh2.army.mil

SIP (Regimental): CW4 Dudley Carver
ATTN: AFZA-AV-SQSN
C: 318-531-7013; DSN: 863-7013
carverd@polk-emh2.army.mil

SIP (Squadron): CW4 Howard Fancher
ATTN: AFZA-AV-SQSN
C: 910-396-9469; DSN: 863-7013
francherh@polk-emh2.army.mil

S-3: MAJ George Hart
ATTN: AFZX-AV-SS3
C: 318-531-7041; DSN: 863-7041
hartg@polk-emh2.army.mil

ASO: CW3 Mark Elig
ATTN: AFZA-AV-SQSA
C: 910-396-9469; DSN: 236-9460
eligm@polk-emh2.army.mil

Senior NCO: CSM John D. LeSane
ATTN: AFZX-AV-CM
C: 318-531-7274; DSN: 863-7274
lesanej@polk-emh2.army.mil

36th Medical Detachment (Helicopter Ambulance)

JRTC
Fort Polk, LA 71459-5000

Commander: MAJ William J.
Miklosey, Jr.
ATTN: AFZX-HC-36
C: 318-531-4803; DSN: 863-4803

Aviation Division, Operations Group, JRTC

Fort Polk, LA 71459



**Senior Aviation
Observer/Controller:**
LTC Julius E. Clark, III
ATTN: ATZL-JRO-U
C: 318-531-0202
DSN: 863-0202
clarksl@polk-
emh2.army.mil

Executive Officer: MAJ Paul Grace
ATTN: ATZL-JRO-U
C: 318-531-0205; DSN: 863-0205

Senior NCO: Master Sergeant (P)
Kumarasiri Wijetunga
ATTN: ATZL-JRO-U
C: 318-531-0204; DSN: 863-0204

**Sr. Special Opns Aviation
Observer/Controller:** MAJ Ronald D.
Tuggle
ATTN: ATZL-JRO-U
C: 318-531-5288; DSN: 863-5288

Sr. TOC Observer/Controller: CPT
Mike Scott
ATTN: ATZL-JRO-U
C: 318-531-0217; DSN: 863-0217

Sr. BDE C2 Observer/Controller:
CPT Nicholas P. Chronis
ATTN: ATZL-JRO-U
C: 318-531-0216; DSN: 863-0216

**Plans/Exercise Maneuver Control
and JACC:** CPT Greg McAfee
ATTN: ATZL-JRO-U
C: 318-531-9604; DSN: 318-531-9604

Senior TAFF Officer: CPT Dale
Watson
ATTN: ATZL-JRO-U
C: 318-531-0658; DSN: 863-0658
watsonde@polk-emh2.army.mil

New Orleans

**Office, State Adjutant General,
Louisiana ARNG**
Headquarters Building
Jackson Barracks
New Orleans, LA 70146-0330

TAG:
BG Bennett C. Landreneau
C: 504-278-8211
DSN: 485-8211
tagla@la-ngnet.army.mil

Office, State Army Aviation Officer, Louisiana ARNG

Aviation Support Facility
6401 Stars & Stripes Blvd., Bldg. 101
New Orleans, LA 70126-8001
SAAO: COL Philip W. Nuss
ATTN: LANG-SAO
C: 504-278-8330; DSN: 485-8330
saola@la-armg.ngb.army.mil

Louisiana Army National Guard Aviation Support Facility #1

6401 Stars & Stripes Blvd.
Building 101
New Orleans, LA 70126-8001
AASFC: LTC Barry D. Keeling
ATTN: LANG-SAO-AA
C: 504-278-8366; DSN: 485-8366
aasf1a@la-ngnet.army.mil

Pineville

**Louisiana Army National Guard
Aviation Support Facility #2**
7615 Ester Field
Pineville, LA 71360-3737

MAINE Augusta

**Office, State Adjutant General, Maine
Army National Guard**
Camp Keyes
Augusta, ME 04333-0033



TAG:
MG Earl L. Adams
C: 207-626-4205
DSN: 476-4205

Bangor

112th Medical Company (AA)
345 Fillmore Street
Bangor, ME 04401-3091

**Office, State Army Aviation Officer,
Maine Army National Guard
Army Aviation Support Facility**

Bldg. 260, BIA, 92 Hayes St.
Bangor, ME 04401-3091
SAAO: LTC Rob Carmichael
ATTN: MEARNG-DOA
C: 207-947-6593; DSN: 881-3450
saome@me-armg.ngb.army.mil

AFTER THE FRAY...AT THE END OF A TOUGH DAY



YOU'LL BE GLAD YOU WERE SITTING ON US!

Simula

ENERGY-ABSORBING SEATS

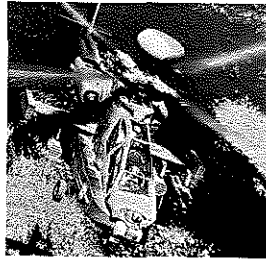

Simula _____

PROUD TO BE ABOARD BLACK HAWK, APACHE, AND POISED FOR CHINOOK

Safety Systems, Inc.

7414 South Hart Ave. • Tempe, Arizona 85283-4307
USA Phone (602) 893-6245 Fax (602) 897-1906
or e-mail at: simsafe7@simula.com

VISIT US AT:
AAAA - Nashville, TN — May 9-12, 1999
EEO/Affirmative Action Employer

Authorized Distributor for: **CHANDLER EVANS CONTROL SYSTEMS DIVISION**

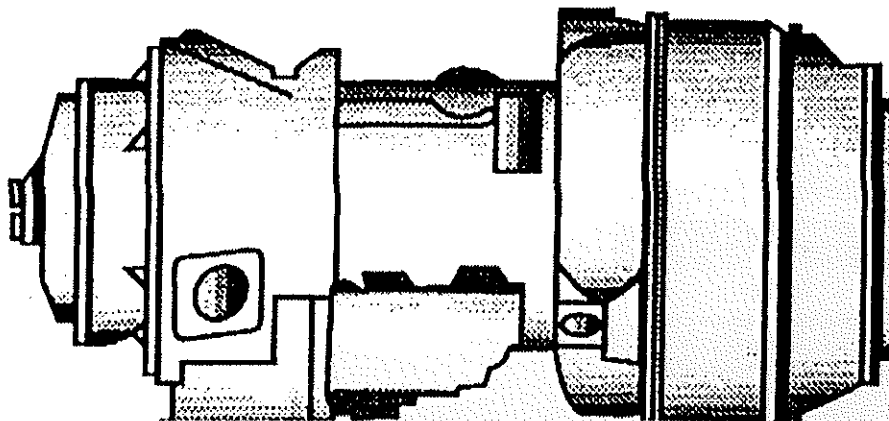

T-53

T-55

ENGINE SUPPORT

TRANSUPPORT, INC.

53 TURBINE WAY • MERRIMACK, NH 03054

<http://www.transupport.com>

PH: 603-424-3111

FAX: 603-424-1888

Maine Army National Guard Army Aviation Support Facility
92 Hayes Street
Building 260
Bangor, ME 04401-3091
AASFC: LTC Rob Carmichael
ATTN: MEARNG-AVN
C: 207-947-6593; DSN: 881-3450

MARYLAND
Aberdeen Proving Ground

29th Aviation Brigade
29th Infantry Division
Bldg. E4305 (Edgewood Area)
Aberdeen Proving Ground, MD 21010-5401
Commander: COL Alberto J. Jimenez
C: 410-436-2451; DSN: 584-2698

Office, State Army Aviation Officer, Maryland Army National Guard Army Aviation Support Facility
Building E4081
Weide AAF, Edgewood
Aberdeen Proving Ground, MD 21010-5401



SAAO:
COL Ronald R. Eaton
ATTN: MD-STARC-DSA
C: 410-436-4402
DSN: 584-4402
saomd@md-arng.ngb.army.mil

Maryland Army National Guard Army Aviation Support Facility
Weide Army Airfield
Building E4081
Edgewood
Aberdeen Proving Ground, MD 21010-5401

Mobilization AVCRAD Control Element (MACE)
Maryland Army National Guard
Building E4305
Aberdeen Proving Ground, MD 21010-5401



Commander:
COL James W. Taneyhill
ATTN: AMSIO-M-CO
C: 410-671-2635
DSN: 584-2635

Safety Division, USATECOM
Aberdeen Proving Ground, MD 21005-5055
Director: Mr. Charles D. (Dave) Sexton
ATTN: AMSTE-SM-S
C: 410-278-1302; DSN: 298-1302
dsexton@tec1.app.army.mil

Baltimore

Office, State Adjutant General, Maryland Army National Guard
5th Regiment Armory
Baltimore, MD 21201-2288



TAG:
MG James F. Fretterd
ATTN: MDNG-AG
C: 410-576-6097
DSN: 496-6097
tagmd@md-ngnet.army.mil

MASSACHUSETTS
Chicopee

Massachusetts Army National Guard Aviation Support Facility #2
Building 7400
Westover Air Force Base
Chicopee, MA 01022-1082
AASF#2C: MAJ Paul G. Thibodeau
ATTN: MAAR-AV-2
C: 413-557-3234; DSN: 589-3234
pt157@aol.com

Milford

Office, State Army Aviation Officer, Massachusetts ARNG
TAGMA
50 Maple Street
Milford, MA 01757
SAAO: LTC Robert E. Welch, Jr.
ATTN: MAAR-AV
C: 508-233-6580; DSN: 256-6580
saoma@ma-arng.ngb.army.mil

Otis Air National Guard Base Massachusetts Army National Guard Army Avn. Support Facility #1
Building 2816
Otis Air Nat'l Guard Base, MA 02542-5002
AASFC: LTC Gregory B. Miller
C: 508-968-5853; DSN: 557-5853
gmiller@capecod.net

Reading

Office, State Adjutant General, Massachusetts ARNG
25 Haverhill Street
Reading, MA 01867-1999



TAG:
MG Raymond A. Vezina
C: 617-944-0500
DSN: 220-2320
tagma@shore.net

MICHIGAN
Grand Ledge

Office, State Army Aviation Officer, Michigan Army National Guard Army Aviation Support Facility
10600 Eaton Highway
Grand Ledge, MI 48837-9102
SAAO: LTC Alan R. Peterson
ATTN: MIAR-AVN
C: 517-627-0108; DSN: 623-0671
saomi@mi-arng.ngb.army.mil

Michigan Army National Guard Army Aviation Support Facility
10600 Eaton Highway
Grand Ledge, MI 48837-9102

Lansing

Office, State Adjutant General, Michigan Army National Guard
2500 S. Washington Avenue
Lansing, MI 48913-5101
TAG: MG E. Gordon Stump
C: 517-483-5507; DSN: 623-0507

MINNESOTA
Camp Ripley

Ray S. Miller Army Airfield
15000 Highway 115
Camp Ripley, MN 56345-4173
Airfield Commander: MAJ Bruce Bartl
C: 320-632-7426; DSN: 871-7426
mansfieldd@mn-arng.ngb.army.mil
Senior NCO: SFC Roger Temple
C: 320-632-7426; DSN: 871-7426

47th ATS Company
15000 Highway 115
Camp Ripley, MN 56345-4173
Company Commander: CPT Paul Maier
ATTN: RBAV-ATS
C: 320-632-7421; DSN: 871-7421
nelsons@mn-arng.ngb.army.mil
Senior NCO: 1SG Bill Davis
ATTN: RBAV-ATS
C: 320-632-7421; DSN: 871-7421

St. Paul

F Company, 147 Aviation Regiment (AVIM)
206 Airport Road
St. Paul, MN 55107-1006
Commander: MAJ Mike Cosmey
ATTN: RBAV-AMC
C: 651-281-3483
moorek@mn-arng.ngb.army.mil
Senior NCO: 1SG Ron Smith
ATTN: RBAV-AMC
C: 651-281-3483

2-147 Aviation Regiment (Assault)
206 Airport Road
St. Paul, MN 55107-1006
Commander: LTC Joseph Schmitz
ATTN: RBAV-ASLT
C: 651-281-3479
EM: switzerml@mn-arng.ngb.army.mil
Senior NCO: CSM Mike Mannion
ATTN: RBAV-ASLT
C: 651-281-3479

3-147 Aviation Regiment (Attack)
206 Airport Road
St. Paul, MN 55107-1006
Commander: LTC John Ohnstad
ATTN: RBAV-ATK
C: 651-281-3438
huddlestonm@mn-arng.ngb.army.mil
Senior NCO: CSM John Ebertowski
ATTN: RBAV-ASLT
C: 651-281-3438

34th Infantry Division Aviation Brigade, Minnesota ARNG
206 Airport Road
St. Paul, MN 55107-1006
Commander: COL Matt Brockway
ATTN: RBAV-CO
C: 651-281-3469
wolfgraml@mn-arng.ngb.army.mil

Senior NCO: CSM Gary Gustner
ATTN: RBAV-CSM
C: 651-281-3469

Office, State Adjutant General, Minnesota ARNG
20 West 12th Street
St. Paul, MN 55155



TAG:
MG Eugene R. Andreotti
C: 651-282-4666
DSN: 825-4666
tag@mn-arng.ngb.army.mil

Office, State Army Aviation Officer, Minnesota ARNG Army Aviation Support Facility
206 Airport Road
St. Paul, MN 55107-1006
SAAO: COL Steven E. DeMars
ATTN: MNAG-SAO
C: 612-281-3403
demars@mn-arng.ngb.army.mil

Minnesota Army National Guard Army Aviation Support Facility
206 Airport Road
St. Paul, MN 55107-1006
AASFC: COL Curt Newcomb
ATTN: MNAG-ASF-Z
C: 612-281-3402; DSN: 825-3402
newcombc@mn-arng.ngb.army.mil

MISSISSIPPI
Gulfport

1108th Aviation Classification Repair Activity Depot (AVCRAD) Mississippi ARNG
P. O. Box 3349
Gulfport, MS 39505-3349
Commander: COL Gervis A. Parkerson
ATTN: CO
C: 228-214-6901; DSN: 363-8901
parkersog@ms-arng.ngb.army.mil

Jackson

Office, State Adjutant General, Mississippi ARNG
P. O. Box 5027
Jackson, MS 39296-5027
TAG: MG James H. Garner
ATTN: NGMS-Z
C: 601-973-6232; DSN: 637-6232
tagms@ms-ngnet.army.mil

Office, State Army Aviation Officer, Mississippi ARNG
Military Department
Fondren Station
P.O. Box 5027
Jackson, MS 39296-5027
SAAO: COL Barron L. Goff
ATTN: NGMS-A
C: 601-973-6301; DSN: 637-6301
saoms@ms-arng.ngb.army.mil

Mississippi Army National Guard Aviation Support Facility #1
365 Shop Street
Hawkins Field
Jackson, MS 39209-3436
AASFC: LTC Dan V. Chisolm
C: 601-354-7540; DSN: 637-6134

ARINC

**Military
and
Commercial
Aviation**

Communications, navigation,
networks, avionics standards,
hardware and software systems integration,
aircraft modifications

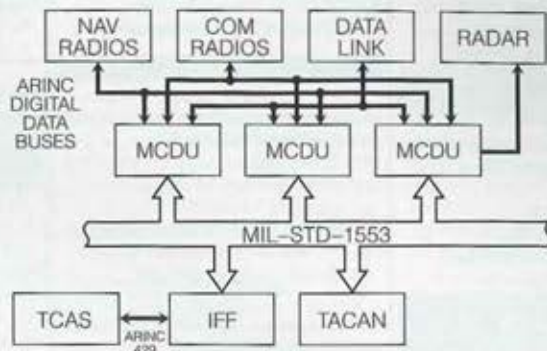

ARINC Incorporated
6703 Odyssey Drive, Suite 104
Huntsville, AL 35806
Tel: 205 922 1022
Fax: 205 922 1026
Web site: www.arinc.com

A RECOGNIZED NAME IN AVIATION SINCE 1929



U.S. GENERAL SERVICES ADMINISTRATION

- ★ Household Appliances
- ★ Industrial Quality Tools

**“The Work Matters. The People Matter.
The Tools Matter.”**

Ordering Methods:

IMPAC® Card Ordering
GSA Advantage!™ at www.fss.gsa.gov
FEDSTRIP/MILSTRIP: Fax to (816) 926-7971
Order Processing: (816) 926-7315 or (816) 926-7316
DSN: 465-7315 or 465-7316



www.r6.gsa.gov/tac

Meridian

Mississippi Army National Guard Aviation Support Facility #3
P. O. Box 4258, West Station
Meridian, MS 39304-4258
AASFC: LTC Felton Watkins
C: 601-484-9500; DSN: 778-9500

Tupelo

Mississippi Army National Guard Aviation Support Facility #2
P. O. Box 2305
Tupelo, MS 38803-2305
AASFC: LTC James G. Young
C: 601-680-8340; DSN: 683-8340
aasf2ms@ms-arng.ngb.army.mil

MISSOURI Belton

146th Aviation Group (Combat)
1200 Westover Road
Belton, MO 64012-4040
Commander: COL James M. Richey
ATTN: AFRC-CKS-AV-C
C: 816-348-2629
Executive Officer: MAJ Allan M. Phaneuf
ATTN: AFRC-CKS-AV-DC
C: 816-348-2631
Senior NCO: CSM Doris Lewis
ATTN: AFRC-AMO-AV-CM
C: 816-348-2628

Fort Leonard Wood

Waynesville Regional Airport at Forney Field Aviation Division, DPTM
Fort Leonard Wood, MO 65473
Airport Manager: Mr. Ronald L. Hodges
ATTN: ATZT-PTM-A
C: 573-596-0165; DSN: 581-0165
hodgesr@wood.army.mil

Jefferson City

Office, State Adjutant General, Missouri Army National Guard
2302 Militia Drive
Jefferson City, MO 65101-1203



TAG:
MG John D. Havens
ATTN: NGMO-ZA
C: 573-526-9710
DSN: 555-9710
tagmo@mo-ngnet.army.mil

Office, State Army Aviation Officer, Missouri Army National Guard Office of the Adjutant General
Ike Shelton Training Site
2302 Militia Drive
Jefferson City, MO 65101-1203



SAAO:
COL Edward C. Gruetzemacher III
ATTN: NGMO-SA
C: 573-526-9634
DSN: 555-9634
gruete@mo-ngnet.army.mil

Missouri Army National Guard Aviation Support Facility #2
Memorial Airport
1225 Cooper Drive
Jefferson City, MO 65101-5007
AASFC: MAJ Edward S. Clark
C: 573-526-9783; DSN: 555-9783

Springfield

Missouri Army National Guard Army Aviation Flight Activity #3
RFD 6, Box 385
Springfield Branson Airport
Springfield, MO 65803-9513
Supervisor: LTC Michael D. Ledbetter
C: 417-895-6610; DSN: 581-1292
aasf3mo@mo-ngnet.army.mil

1107th Aviation Classification Repair Activity Depot (AVCRAD)
Missouri ARNG
2501 Lester Jones Avenue
Springfield Branson Airport
Springfield, MO 65803-9513
Commander: COL Gary C. Jones
C: 417-895-6600; DSN 581-1292

St. Louis

U.S. Army Reserve Personnel Center, Aviation Branch
ATTN: DARP-OPC-AV
9700 Page Boulevard
St. Louis, MO 63132-5200
Branch Chief: LTC James D. Buckles, II
ATTN: DARP-OPC-AV
C: 314-538-3565; DSN: 892-3565

Warrensburg

35th Aviation Brigade
343 E. Gay Street
Warrensburg, MO 64093-1958
Commander: COL Dalton Wright
ATTN: AVN-C
C: 660-543-7938
wqrkaa@mo-ngnet.army.mil

Whiteman Air Force Base

Missouri Army National Guard Aviation Support Facility #1
907 Arnold Avenue
Whiteman Air Force Base, MO 65305-5332
AASF: LTC Kenneth B. McNeel
ATTN: WAASF
C: 660-687-5771; DSN: 975-5771

MONTANA Helena

Office, State Adjutant General, Montana Army National Guard
P. O. Box 4789
Helena, MT 59604-4789
TAG: MG John E. Prendergast
ATTN: AG
C: 406-444-6910; DSN: 747-3010

State Army Aviation Officer, Montana Army National Guard Army Aviation Support Facility
P. O. Box 4789
Helena, MT 59604-4789
SAAO: COL Robert W. Van Meter
ATTN: DCSAVN
C: 406-841-3033; DSN: 747-3033
vanmeterw@mt-arng.ngb.army.mil

A Co, 1-189th CSAB

P. O. Box 4789
Helena, MT 59604-4789
Commander: CPT John Spencer
C: 406-841-3500; DSN: 747-3500
Senior NCO: 1SG Charles Loendorf
C: 406-841-3500; DSN: 747-3500

Montana Army Aviation Guard Army Aviation Support Facility

P. O. Box 4789
Helena, MT 59604-4789
AASFC: MAJ Kevin M. Kepler
ATTN: AASF-CDR
C: 406-841-3035; DSN: 747-3035
EM: keplerkm@mt-arng.ngb.army.mil
Maintenance Officer: CW4 Marvin Waples
C: 406-841-3048; DSN: 747-3048
Operations Officer: CPT Thomas Malee
C: 406-841-3035; DSN: 747-3035
ASO: CW4 Ken Inabnit
C: 406-841-3035; DSN: 747-3035

B Co., 1-112th LUH

P. O. Box 4789
Helena, MT 59604-4789
Commander: CPT Eric Waldorf
C: 406-841-3500; DSN: 747-3500
Senior NCO: 1SG Ronald Rasmussen
C: 406-841-3500; DSN: 747-3500

C Co., 1-112th LUH

P. O. Box 4789
Helena, MT 59604-4789
Commander: CPT Garth Scott
C: 406-841-3500; DSN: 747-3500
Senior NCO: 1SG David Bock
C: 406-841-3500; DSN: 747-3500

Det 1, 1085th MED

P. O. Box 4789
Helena, MT 59604-4789
Commander: CPT Mark McGinley
C: 406-841-3500; DSN: 747-3500

HHC 1-189th CSAB

P. O. Box 4789
Helena, MT 59604-4789
Commander: CPT Randy Dooley
C: 406-841-3500; DSN: 747-3500
Senior NCO: 1SG Dennis Streeter
C: 406-841-3500; DSN: 747-3500

1-189th CSAB

P. O. Box 4789
Helena, MT 59604-4789
Commander: LTC Kevin J. Collins
ATTN: AASF-CDR
C: 406-841-3500; DSN: 747-3500
collinskj@mt-arng.ngb.army.mil
Executive Officer: MAJ David McGuire
C: 406-841-3500; DSN: 747-3500
S3: MAJ Scott Smith
C: 406-841-3500; DSN: 747-3500
Senior NCO: CSM Kent Robinson
C: 406-841-3500; DSN: 747-3500

NEBRASKA Lincoln

1st Squadron, 167th Cavalry
2400 NW 24th Street
Lincoln, NE 68524-1892

Commander: LTC Thomas E. Johnson
ATTN: 92TC-CAV
C: 402-471-7468; DSN: 946-7185

24th Medical Company (Air Ambulance)

2400 NW 24th Street
Lincoln, NE 68524-1892
Commander: MAJ Scott A. Gronewold
ATTN: NETC-AMED
C: 402-471-7322; DSN: 946-7480

Office, State Adjutant General, Nebraska Army National Guard
1300 Military Road
Lincoln, NE 68508-1090



TAG:
MG Stanley M. Heng
C: 402-471-7114
DSN: 946-7114

Office, State Army Aviation Officer, Nebraska Army National Guard Army Aviation Support Facility
2601 NW 25th
Lincoln, NE 68524-1898



SAAO:
COL Rodney F. Dyer
ATTN: AASF-DAVN
C: 402-471-7450
DSN: 946-7450
davnne@mil.state.ne.us

Nebraska Army National Guard Army Aviation Support Facility
2601 NW 25th Street
Lincoln, NE 68524-1898

NEVADA Carson City

Office, State Adjutant General, Nevada National Guard
2525 South Carson Street
Carson City, NV 89701-5502



TAG:
Maj. Gen. Drennan A. Clark, USAF
C: 702-887-7302
DSN: 830-5302
tagnv@nv-ngnet.army.mil

Reno

717th Medical Company, Detach. 1
19980 Army Aviation Drive
Reno, NV 89506-1200
Commander: CPT Daniel R. Waters
ATTN: NVTI-MD-Z
C: 902-971-6061; DSN: 830-5267
littled@nv.arng.ngb.army.mil

**Office, State Army Aviation Officer,
Nevada Army National Guard
Army Aviation Support Facility**
20,000 Army Aviation Drive
Reno-Stead Airport
Reno, NV 89506-1200
SAAO: MAJ Robert T. Herbert
ATTN: NVMD-AV
C: 702-972-2701; DSN: 830-5267
aasfz@nv-ngnet.army.mil

**Nevada Army National Guard Army
Aviation Support Facility**
20000 Army Aviation Drive
Reno-Stead Airport
Reno, NV 89506-1200
AASFC: MAJ Robert T. Herbert
ATTN: NVMD-AV
C: 702-972-2701; DSN: 830-5267
EM: aasfz@nv-ngnet.army.mil

NEW HAMPSHIRE Concord

**Office, State Adjutant General, New
Hampshire ARNG**
#1 Airport Road
Concord, NH 03301-5353
TAG: BG John E. Blair
C: 603-225-1200; DSN: 684-9257
tagnh@ngnet.army.mil

**Office, State Army Aviation Officer,
New Hampshire ARNG**
Army Aviation Support Facility
4 Pembroke Rd.
Concord, NH 03301-5652
SAAO: MAJ Frank C. Leith
ATTN: NHAG-AV
C: 603-225-1270; DSN: 684-9292

**New Hampshire Army National
Guard Army Aviation Support
Facility**
4 Pembroke Rd.
Concord, NH 03301-5652
AASFC: MAJ Frank Leith
ATTN: NHAG-AV
C: 603-225-1270; DSN: 684-9292

NEW JERSEY Fort Monmouth

**U.S. Army Command Control
Systems/Avionics Directorate
RDEC, USACECOM**
Fort Monmouth, NJ 07703-5603
Acting Director: Mr. William Carl
ATTN: AMSEL-LC-CCS
C: 732-532-2332; DSN: 992-2332
carl@doim6.monmouth.army.mil

**Airborne NAVCOM Division,
CCS/Avionics Directorate, CECOM**
Fort Monmouth, NJ 07703
Chief: Mr. Richard E. Pribyl
ATTN: AMSEL-LC-CCS-N
C: 732-323-1957; DSN: 992-1957
pribyl@doim6.monmouth.army.mil

**Airborne Communications Branch,
CCS/Avionics Directorate, CECOM**
Fort Monmouth, NJ 07703
Chief: Mr. Charles Coleman
ATTN: AMSEL-LC-CCS-N-AC
C: 732-323-2416; DSN: 992-2416
coleman@doim6.monmouth.army.mil

**irborne Navigation Branch,
CCS/Avionics Directorate, CECOM**
Fort Monmouth, NJ 07703
Chief: Mr. Jack Broeckelmann
ATTN: AMSEL-LC-CCS-N-AN
C: 732-323-3652; DSN: 992-3652
broeckel@doim6.monmouth.army.mil

**Aircraft Programs Branch,
CCS/Avionics Directorate, CECOM**
Fort Monmouth, NJ 07703
Chief: Ms. Colleen DeGroot
ATTN: AMSEL-LC-CCS-N-AA
C: 732-532-3568; DSN: 992-3568
degroodc@doim6.monmouth.army.mil

**Airborne Mission Division,
CCS/Avionics Directorate, CECOM**
Fort Monmouth, NJ 07703
Chief: Mr. Michael Gurgos
ATTN: AMSEL-LC-CCS-A
C: 732-532-5431; DSN: 992-5431
gurgos@doim6.monmouth.army.mil

**Aircraft Survivability Branch,
CCS/Avionics Directorate, CECOM**
Fort Monmouth, NJ 07703
Chief: Mr. Harry Ivory
ATTN: AMSEL-LC-CCS-A-AS
C: 732-532-3400; DSN: 992-3400
ivory-1@doim6.monmouth.army.mil

**Mission Management/Survival Radio
Br., CCS/Avionics Dir., CECOM**
Fort Monmouth, NJ 07703
Chief: Mr. Gabor Boda
ATTN: AMSEL-LC-CCS-A-M
C: 732-532-5107; DSN: 992-5107
boda@doim6.monmouth.army.mil

**Avionics Branch, A/IEWS Division,
USA CECOM SEC**
Fort Monmouth, NJ 07703-5207
Chief: Mr. Ronald V. Kurowsky
ATTN: AMSEL-SE-WS-AI-AV
C: 732-427-3550; DSN: 987-3550
kurowsky@doim6.monmouth.army.mil

Picatinny Arsenal

**New Jersey Army National Guard
Aviation Support Facility #2**
Building 3801
Picatinny Arsenal, NJ 07801-5000
AASFC: LTC Jorge J. Martinez
C: 973-724-4609; DSN: 880-4609
EM: aasf2nj@nj-arng.ngb.army.mil

Trenton

**Office, State Adjutant General, New
Jersey ARNG**
P.O. Box 340
Trenton, NJ 08625-0340



TAG:
MG Paul J. Glazar
ATTN: TAG
C: 609-530-6957
DSN: 445-9957
glazar@dmava.
state.nj.us

West Trenton

1st Battalion, 150th Aviation
Scotch Road
West Trenton, NJ 08628-1389
Commander: LTC Paul J. Ciervo
C: 609-530-4267

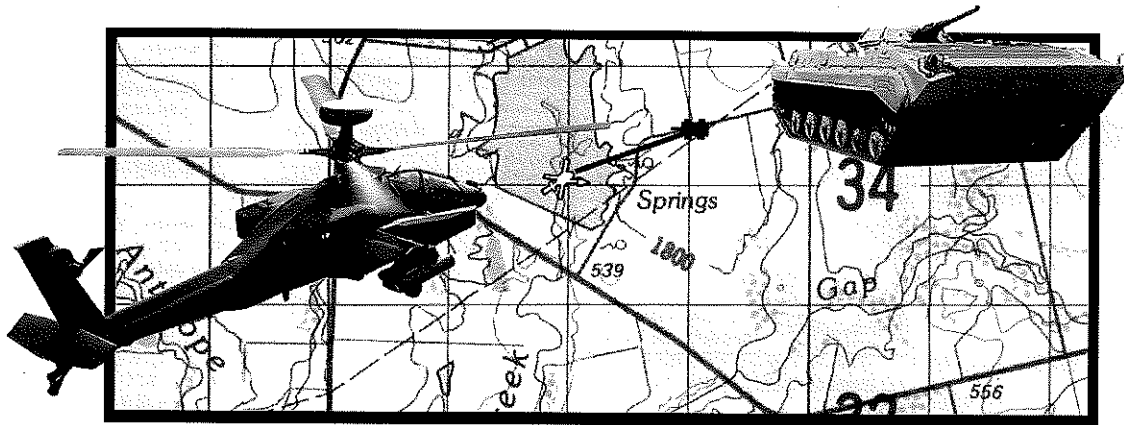

Play Outside the Box

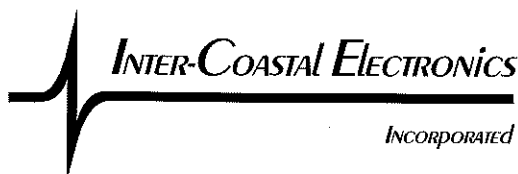

Now Inter-Coastal Electronics (ICE) brings affordable Live Simulation Training with Combat Training Center fidelity to your Home Station. Currently fielded with the 21st Cavalry.

PH (602) 981-6898 / FX (602) 981-6899

Executive Officer: MAJ John C. Dillie
 C: 609-530-4267
SIP: CW3 Glen E. Malin
 C: 609-530-4267
ASO: CW4 Gary A. Brenfleck
 C: 609-530-4267
Senior NCO: CSM James H. Marshall
 C: 609-530-4267

**Office, State Army Aviation Officer,
 New Jersey ARNG**
 Dept. of Military & Vet. Affrs.
 Trenton-Mercer County Airport
 152 Scotch Road
 West Trenton, NJ 08628-1389



SAAO:
 COL Michael B. Smith
 ATTN: SAAO
 C: 609-530-4802
 DSN: 445-9221
 smithrb@nj-
 arng.ngb.army.mil

**New Jersey Army National Guard
 Aviation Support Facility #1**
 Trenton Mercer Airport, Scotch Road
 West Trenton, NJ 08628-1302
AASFC: LTC Paul J. Ciervo
 ATTN: AASFC
 C: 609-530-4256; DSN: 445-9261
 aasf1nj@nj-arng.ngb.army.mil

NEW MEXICO Holloman Air Force Base

U.S. Army Air Operations Division
 P.O. Box 1089
 Holloman Air Force Base, NM 88330
Director: CW5 Lawrence A. Morgan
 ATTN: STEWS-NRS-A
 C: 505-475-1330; DSN: 867-1330
 stews-aa@wsmr-emh15.army.mil
Chief Opn. Div: Mr. Clyde P. Wilson
 ATTN: STEWS-NRS-AO
 C: 505-475-1343; DSN: 867-1343
 stews-aa@wsmr-emh15.army.mil

Las Cruces

**New Mexico Army National Guard
 RAID Flight Activity**
 8950 Zia Blvd. #10
 Las Cruces, NM 88005
Commander: 1LT W. Bryan Dennis
 ATTN: NMAG-RD
 C: 505-541-6802

Santa Fe

**Office, State Adjutant General, New
 Mexico ARNG**
 47 Bataan Boulevard
 Santa Fe, NM 87505
TAG: MG Melvyn S. Montano
 C: 505-474-1202; DSN: 867-8202

**Office, State Army Aviation Officer,
 New Mexico ARNG**
 47 Bataan Blvd.
 Santa Fe, NM 87505-4685
SAAO:
 MAJ Virgil Vigil
 ATTN: NMAG-AAV
 C: 505-474-1315
 DSN: 867-8315
 saonim@nm-arng.ngb.army.mil

**New Mexico Army National Guard
 Army Aviation Support Facility**
 P. O. Box 4277
 Santa Fe, NM 87501-4277

NEW YORK Fort Drum

**U.S. Army Garrison
 Aviation Division**
 Fort Drum, NY 13602-5000
Aviation Officer and Airfield Cdr: Mr.
 Joe White
 ATTN: AFZS-RBC-A
 C: 315-772-4480; DSN: 341-4480
 whitej@drum-emh4.army.mil
Dep. Cdr: Ron Blinbrey
 ATTN: AFZS-RBC-A
 C: 315-772-5314; DSN: 341-5314
 afzs-rbc-a@drum-emh4.army.mil
Senior NCO: SGT Ernie Gunter

**10th Aviation Brigade, 10th Mountain
 Division (Light)**
 Fort Drum, NY 13602



Commander:
 COL David P.
 Brostrom
 ATTN: AFZS-AV-Z
 C: 315-772-3177
 DSN: 341-3177
 brostromd@drum-
 emh4.army.mil

Executive Officer: LTC Paul R. Disney
 ATTN: AFZS-AV-Z
 C: 315-772-3091; DSN: 341-3091
 disney@drum-pop.army.mil
SIP: CW4 William A. Church
 ATTN: AFZS-AV-Z-SS
 C: 315-772-3402; DSN: 341-3402
ASO: CW4 John R. Fix
 ATTN: AFZS-AV-Z-SS
 C: 315-772-3402; DSN: 341-3402
 afzs-av-ss@drum-emh4.army.mil
MTFE: CW4 Richard C. Boss
 ATTN: AFZS-AV-Z-AMO
 C: 315-772-3226; DSN: 341-3226
 bossr@drum.emh4.army.mil



Senior NCO:
 CSM Robert R.
 Stubblefield
 ATTN: AFZS-AV-Z-
 CSM
 C: 315-772-3175
 DSN: 341-3175
 stubblefieldr@drum-
 emh4.army.mil

**1st Battalion (Attack), 10th Aviation
 Regiment**
10th Aviation Brigade
10th Mountain Division (L)
 Fort Drum, NY 13602-5230
Commander: LTC Jerry D. Scott
 ATTN: AFZS-AV-A
 C: 315-772-3000; DSN: 341-3000
 scottj@drum-emh4.army.mil
Executive Officer: MAJ Richard M.
 Beckinger
 ATTN: AFZS-AV-AT
 C: 315-772-3750; DSN: 341-3750
 beckingerr@drum-emh4.army.mil
SIP: CW3(P) Ronald Smith
 ATTN: AFZS-AV-A
 C: 315-772-3802; DSN: 341-3802
 EM: smithr@drum-emh4.army.mil

ASO: CW3 Dave Spooner
 ATTN: AFZS-AV-ATK
 C: 315-772-3806; DSN: 341-3806
 spoonerd@drum-emh1.army.mil
Senior NCO: 1SG Melvin Moton
 ATTN: AFZS-AV-ATK
 C: 315-772-3745; DSN: 341-3745
 motonm@drum-emh4.army.mil

**2nd Battalion, 10th Aviation
 Regiment**
 Bldg. 10420
 South Riva Ridge
 Fort Drum, NY 13601



Commander:
 LTC Shane M. Deverill
 ATTN: AFZS-AV-AHB
 C: 315-772-4305
 DSN: 341-4305

Executive Officer: MAJ Jonathan J.
 Reinebold
 ATTN: AFVS-AV-AHB
 C: 315-772-4687; DSN: 341-4687
SIP: CW3 David A. Kenny
 ATTN: AFZS-AV-AHB
 C: 315-772-5853; DSN: 341-5863
ASO: CW4 William E. Wallace
 ATTN: AFZS-AV-AHB
 C: 315-772-4416; DSN: 341-4416
MTFE: CW4 Armond Brasseur
 ATTN: AFZS-AV-AHB
 C: 315-772-6619; DSN: 341-6619



Senior NCO:
 CSM Timothy D. Paul
 ATTN: AFZS-AV-AHB
 C: 315-772-4290
 DSN: 341-4290

3d Squadron, 17th Cavalry
 10410 South Riva Ridge Drive
 Fort Drum, NY 13602-5231
Commander: LTC Walter L. Davis
 ATTN: AFZS-AV-CAV
 C: 315-772-9052; DSN: 341-9052
Executive Officer: MAJ Edward P.
 Laviviere
 ATTN: AFZS-AV-CAV-XO
 C: 315-772-3367; DSN: 341-3367
SIP: CW3 Lee Tulin
 ATTN: AFZS-AV-CAV-ST
 C: 315-772-3350; DSN: 341-3350
Senior NCO: CSM Robert M.
 Stubblefield
 ATTN: AFZS-AV-CAV-CSM
 C: 315-772-3090; DSN: 341-3090

Latham

**Office, State Adjutant General, New
 York Army National Guard**
 330 Old Niskayuna Road
 Latham, NY 12110-2224



TAG:
 MG John H.V.
 Fenimore
 C: 518-786-4502
 DSN: 489-4502

**Office, State Army Aviation Officer,
 New York Army National Guard
 Army Aviation Support Fac. #3**
 Albany International Airport
 Latham, NY 12110-2299



SAAO:
 LTC David Sheppard
 ATTN: MNAV
 C: 518-786-4397
 DSN: 489-4397
 saony@ny-ngnet.
 army.mil

**New York Army National Guard
 Aviation Support Facility #3**
 309 Old Niskayuna Rd.
 Latham, NY 12110-2299
AASFC: LTC Alan J. Murray
 C: 518-786-4360; DSN: 489-4360

New Windsor

**U.S. Military Academy Flight
 Detachment**
 2nd Aviation Detachment
 United States Military Academy
 P. O. 9000
 New Windsor, NY 12553



Commander:
 CW5 Donald W.
 Dennis
 ATTN: MABS-H-C
 C: 914-567-1088
 yd5957@exmail.
 usma.army.mil

Patchogue

42d Aviation Brigade
12d Infantry Division
 400 Barton Avenue
 Patchogue, NY 11772-1402
Commander: COL John A. Meskill
 ATTN: AVBDE-CDR
 C: 516-447-0670

Rochester

**1st Battalion, 142d Aviation
 Regiment, NYARNG**
 AH-1F
 250 Weidner Road
 Rochester, NY 14624-5136
Commander: LTC Joseph S. Songin
 C: 716-783-5314; DSN: 343-5314
 jssongin@sprintmail.com
Senior NCO: CSM Justin F. Cappon
 C: 716-893-5314; DSN: 343-5314

**New York Army National Guard
 Aviation Support Facility #2**
 280 Weidner Road
 Rochester, NY 14624-5136
Commander: MAJ Michael E. Bobeck
 AASF#2-C
 C: 716-783-5400; DSN: 343-5400
 asf2@dmna.state.ny.us
Operations Officers: CW4 Anthony F.
 Castiglione
 C: 716-783-5405; DSN: 343-5405
 aasf2@dmna.state.ny.us
Safety Officer: CW5 Francis A. Rotella
 C: 716-783-5403; DSN: 343-5403
 aasf2@dmna.state.ny.us

Maintenance Officer: CW4 Robert L. Fritz
C: 716-783-5402; DSN: 343-5402
aasf2@dmna.state.ny.us

Ronkonkoma

**New York Army National Guard
Aviation Support Facility #1
Hangar A**
Long Island MacArthur Airport
Ronkonkoma, NY 11779-7302
AAFSC: COL Frank P. Intini, Jr.
ATTN: AASF#1
C: 516-737-6210; DSN: 247-6275

NORTH CAROLINA Fort Bragg

**Aviation Division, DPTM, Simmons
Army Airfield**
Fort Bragg, NC 28307-5000
Post Aviation Officer: Mr. Aaron
Spencer
ATTN: AFZA-DPT-S
C: 910-396-6605; DSN: 236-6605
spencera@emh5.bragg.army.mil

**Office, DCS for Special Operations
Aviation, USASOCOM**
Fort Bragg, NC 28307-5200
**Deputy Chief of Staff, Special
Operations Aviation:** COL Telford
Larew
ATTN: AOAO
C: 910-432-4366; DSN: 239-4366
larewt@soc.mil

**Chief, Operations, Plans and
Training:** LTC Ed Woods
ATTN: AOAO-OPT
C: 910-432-8481; DSN: 239-8481
woodse@soc.mil
MACOM Aviation Safety Officer: Mr.
James Dietderich
ATTN: AOAO-ASO
C: 910-432-3594; DSN: 239-3594
dietderj@soc.mil
MACOM Aviation Standards Officer:
CW4 Billy Johnson
ATTN: AOAO-STD
C: 910-432-7706; DSN: 239-7706
johnsobi@soc.mil

XVIII Airborne Corps Aviation Office
Building P4039
Fort Bragg, NC 28307-5000

**Deputy Corps Aviation Officer
(DCAO), Commanding:** LTC William
Bryson
ATTN: AFZA-CA
C: 910-396-4788; DSN: 236-4788
bryson@bragg.army.mil
ASO: CW5 Peter R. Kalogris
ATTN: AFZA-CA-AS
C: 910-396-4788; DSN: 236-4788
kalogrispr@bragg.army.mil
SIP: CW5 James Wise
ATTN: AFZA-CA-SI
C: 910-396-4788; DSN: 236-4788
CW5JimWise@hotmail.com
MTFE: CW4 Terrence El
C: 910-396-4788; DSN: 236-4788
Elt@bragg.army.mil
Senior NCO: Master Sergeant Todaro
ATTN: AFZA-CA
C: 910-396-6274; DSN: 236-6274

**18th Aviation Brigade
XVIII Airborne Corps**
Fort Bragg, NC 28307-5000
Commander: COL Michael C. Flowers
ATTN: AFZA-AV-CO
C: 910-396-8790; DSN: 236-8790
flowersm@bragg.army.mil
Executive Officer: MAJ(P) Thurman
Pittman
ATTN: AFZA-AV-CX
C: 910-396-7767; DSN: 236-7767
pittmantm@bragg.army.mil
SIP: CW5 James A. Mankie
ATTN: AFZA-AV-CC-SD
C: 910-396-6179; DSN: 236-6179
mankiea@bragg.army.mil
ASO: CW5 Larry Newsom
ATTN: AFZA-AV-CS
C: 910-396-6179; DSN: 236-6179
newsoml@emh5.bragg.army.mil
Senior NCO: CSM George T.
Williamson
ATTN: AFZA-AV-CSM
C: 910-396-7767; DSN: 236-7767
willlag2@bragg.army.mil

1st Battalion, 159th Aviation Regiment

**18th Aviation Brigade
XVIII Airborne Corps**
Fort Bragg, NC 28307-5000
Commander: LTC Charles Breslin
ATTN: AFZA-AV-CMD-BN
C: 910-396-3533; DSN: 236-3533
breslinc@emh5.bragg.army.mil

1st Battalion, 58th Aviation Regiment (Corps) (Airborne)

18th Aviation Brigade
Fort Bragg, NC 28307-5000
Commander: LTC Michael A. Powell
ATTN: AFZA-AV-ATC-BC
C: 910-396-3361; DSN: 236-3361
powellm@emh5.bragg.army.mil
Executive Officer: MAJ David L.
Thomas
ATTN: AFZA-AV-ATC-XO
C: 910-396-8837; DSN: 236-8837
thomasd2@emh5.bragg.army.mil
S-2/3: MAJ Peri Anest
ATTN: AFZA-AV-ATC-S3
C: 910-396-5201; DSN: 236-5201
Signal Maintenance Officer: CW2
William Huerth
ATTN: AFZA-AV-ATC-BMO
C: 910-396-7786; DSN: 236-7786
A2C2 NCOIC: SFC Chester Lambert
ATTN: AFZA-AV-ATC-A2C2
C: 910-396-6350; DSN: 236-6350
gorakm@emh5.bragg.army.mil
Senior NCO: CSM George Williamson
ATTN: AFZA-AV-ATC-CSM
C: 910-396-8837; DSN: 236-8837
willlag2@emh5.bragg.army.mil

2d Battalion, 159th Aviation Regiment 18th Aviation Brigade

XVIII Airborne Corps
Fort Bragg, NC 28307-5000
Commander: LTC Richard D. Miller
ATTN: AFZA-AV-CHD-BC
C: 910-396-7300; DSN: 236-7300
SIP: CW3 Richard Davis III
AFZA-AV-CHD-STD
C: 910-396-5101; DSN: 236-5101
ASO: CW4 Aaron S. Ostrander
ATTN: AFZA-AV-CHD-SF
C: 910-396-5101; DSN: 236-5101

MTFE: CW4 James Smith
ATTN: AFZA-AV-CHD-A
C: 910-396-9713; DSN: 236-9713

82d Aviation Brigade 82d Airborne Division

Fort Bragg, NC 28307
Commander:
COL Jim Rabon
ATTN: AFVC-E
C: 910-432-2604
DSN: 239-2604
rabonj@bragg.
army.mil



Executive Officer: LTC Ronnie Foxx
ATTN: AFVC-E
C: 910-432-1501; DSN: 239-1501
foxxrl@bragg.army.mil
SIP: CW4 Willis Haas
ATTN: AFVC-E
C: 910-432-5174; DSN: 239-5174
haaswe@bragg.army.mil
ASO: CW5 R. Jon Dickinson
ATTN: AFVC-E
C: 910-432-5174; DSN: 239-5174
dickinsr@bragg-emh1.army.mil



1st Squadron (AIR), 17th Cavalry Regiment

**82d Aviation Brigade
82d Airborne Division**
Fort Bragg, NC 28306
Commander: LTC Michael R. Caram
ATTN: AFVC-EC
C: 910-432-2889; DSN: 239-2889
carammr@bragg.army.mil
Executive Officer: MAJ Robert Hein
ATTN: AFVC-EC
C: 910-432-2890; DSN: 239-2890
heindr@bragg.army.mil
SIP: CW4 Erik Schimmer
ATTN: AFVC-EC
C: 910-396-5410; DSN: 239-5410
ASO: CW3 Greg Goldsmith
ATTN: AFVC-EC
C: 910-396-5410; DSN: 236-5410
MTFE: CW3 Pete Phillips
ATTN: AFVC-EC
C: 910-396-3674; DSN: 236-3674
Senior NCO: CSM Michael Banks
ATTN: AFVC-EC
C: 910-432-2889; DSN: 239-2889

1st Attack Helicopter Battalion 82d Aviation Brigade

82d Airborne Division
Fort Bragg, NC 28307
Commander: LTC David W. Shaffer
ATTN: AFVC-EA
C: 910-432-6098; DSN: 239-6098
shafferd@emh5.bragg.army.mil
Executive Officer: MAJ Robert D.
Marcinkowski
ATTN: AFVC-EA
C: 910-432-8926; DSN: 239-8926
marcinkr@emh5.bragg.army.mil

SIP: CW4 Carlton R. Jenkins
ATTN: AFVC-EA
C: 910-396-4345; DSN: 236-4345
ASO: CW2 Mark A. Martin
ATTN: AFVC-EA
C: 910-396-2614; DSN: 236-2614
MTFE: CW4 Randy Olson
ATTN: AFVC-EA
C: 910-396-7163; DSN: 236-7163
Senior NCO: CSM Demitrio Orden
ATTN: AFVC-EA
C: 910-432-6098; DSN: 239-6098
ordend@emh5.bragg.army.mil

2d Battalion (Assault), 82d Aviation Regiment 82d Aviation Brigade 82d Airborne Division

Fort Bragg, NC 28307
Commander:
LTC Mason W.
Thornal
ATTN: AFVC-EB
C: 910-432-7928
DSN: 239-7928
thornalm@bragg.
army.mil



Executive Officer: MAJ Scott
Waggoner
ATTN: AFVC-EB
C: 910-432-8990; DSN: 239-8990
waggones@bragg.army.mil
SIP: CW4 Anthony Acosta
ATTN: AFVC-EB
C: 910-396-1150; DSN: 236-1150
acostaan@bragg.army.mil
ASO: CW4 Ronald Underhill
ATTN: AFVC-EB
C: 910-396-1150; DSN: 236-1150
MTFE: CW3 George Kunkle
ATTN: AFVC-EB
C: 910-396-9377; DSN: 236-9377



56th Medical Evacuation Battalion

Fort Bragg, NC 28307-5000
Commander: LTC Thomas Bailey
ATTN: AFZA-MB-F
C: 910-396-4390; DSN: 236-4390
baileyt@bragg.army.mil
Executive Officer: MAJ Van Joy
ATTN: AFZA-MB-FO
C: 910-396-4390; DSN: 236-4390
joyv@bragg.army.mil
SIP: CW5 Greg Reese
ATTN: AFZA-MB-FS
C: 910-396-5503
reeseeg@bragg.army.mil
ASO: CW3 Michael Turner
ATTN: AFZA-MB-FS
C: 910-396-5503; DSN: 236-5503
turnermich@bragg.army.mil
Senior NCO: CSM Carl McCloud
ATTN: AFZA-MB-FCM
C: 910-396-4390; DSN: 236-4390
mcloudc@bragg.army.mil

57th Medical Company (Air Ambulance)
Fort Bragg, NC 28307-5000
Commander: MAJ Harold L. Abner
ATTN: AFZA-MB-Q
C: 910-396-0029; DSN: 236-0029
abnerh@bragg.army.mil

229th Aviation Regiment (Airborne)
Fort Bragg, NC 28307-5000



Commander:
COL Wayne R. Sears
ATTN: AFZA-ATK-RCO
C: 910-396-4813
DSN: 236-4813
searsw@bragg.army.mil

Executive Officer: MAJ Grant A. Webb
ATTN: AFZA-AR-RXO
C: 910-396-2379; DSN: 236-2379
webbg@bragg.army.mil
SIP: CW4 Craig Winters
ATTN: AFZA-AR-SIP
C: 910-396-1478; DSN: 236-1478
ASO: CW4 Richard Epler
ATTN: AFZA-AR-RASO
C: 910-396-7960; DSN: 236-7960
eppler@bragg.army.mil
MTFE: CW4 Paul Mullen
ATTN: AFZA-AR-MTFE
C: 910-396-7480; DSN: 236-7480



Senior NCO:
CSM Earl M. Cline
ATTN: AFZA-AR-RCSM
C: 910-396-1490
DSN: 236-1490
clinee@bragg.army.mil

1st Battalion, 229th Aviation Regiment
Fort Bragg, NC 28307



Commander:
LTC M. Vance Sales, Jr.
ATTN: AFZA-AR-A-CO
C: 910-396-8932
DSN: 236-8932
salesm@emh5.bragg.army.mil

Executive Officer: MAJ Craig H. Bird
ATTN: AFZA-AR-A-XO
C: 910-396-3149; DSN: 236-3149
birdc@emh5.bragg.army.mil
SIP: CW3 George O'Boyle
ATTN: AFZA-AR-A-SIP
C: 910-396-6063; DSN: 236-6063
ASO: CW3 Jon M. Lane
ATTN: AFZA-AR-A-ASO
C: 910-396-6063; DSN: 236-6063
MTFE: CW4 Dale Wicks
C: 910-396-2645; DSN: 236-2645
Senior NCO: CSM Walter Hardy
ATTN: AFZA-AR-A-CSM
C: 910-396-5094; DSN: 236-5094
hardyw@emh5.bragg.army.mil

3d Battalion, 229th Aviation Regiment "Hell's Angels"
Fort Bragg, NC 28307-5000
Commander: LTC Kirt T. Hardy
ATTN: AFZA-AV-ATK-HA-CDR
C: 910-396-7477; DSN: 236-7477
hardyk@bragg.army.mil

Executive Officer: MAJ Chandler C. Sherrell
ATTN: AFZA-AV-ATK-HA-XO
C: 910-396-5880; DSN: 236-5880
Sherrelc@bragg.army.mil
SIP: CW4 Terry Kuhn
ATTN: AFZA-AV-ATK-HA-SIP
C: 910-396-7618; DSN: 236-7618
ASO: CW3 James Oliphant
ATTN: AFZA-AV-ATK-HA-ASO
C: 910-396-7614; DSN: 236-7614
oliphantja@bragg.army.mil
MTFE: CW3 Christopher Bullinger
ATTN: AFZA-AV-ATK-HA-D
C: 910-396-5198; DSN: 236-5198
Senior NCO: CSM Luis M. Torres
ATTN: AFZA-AV-ATK-HA-CSM
C: 910-396-5260; DSN: 236-5260
torresl@bragg.army.mil

Avn. Section, U.S. Army Airborne & Special Opns. Test Directorate
Fort Bragg, NC 28307-5000
Chief of Aviation: Mr. John Young
ATTN: ATXA-BDO-AV
C: 910-396-4704; DSN: 236-4704

Kinston

449th Aviation Group
Route 7, Box 88-A
Kinston, NC 28501
Commander: COL Ivan T. Beach
C: 919-526-2613

Morrisville

North Carolina Army National Guard Aviation Support Facility #1
Raleigh-Durham Airport
P. O. Box B
Morrisville, NC 27560-8002
AASFC: MAJ Ray Blackmon
ATTN: AASF#1 NCARNG
C: 919-664-7506; DSN: 582-9291
aasf1nc@nc-arng.ngb.army.mil

Raleigh

Office, State Adjutant General, North Carolina ARNG
4105 Reedy Creek Road
Raleigh, NC 27607-6410
TAG: MG Gerald A. Rudisill, Jr.
C: 919-664-6101; DSN: 582-9101

Office, State Army Aviation Officer, North Carolina ARNG
Office of the Adjutant General
4105 Reedy Creek Road
Raleigh, NC 27607-6410



SAAO:
LTC Andrew W. Goodwin
ATTN: AGAV
C: 919-664-6149
DSN: 582-9149
saonc@nc-arng.ngb.army.mil

Salisbury

North Carolina Army National Guard Aviation Support Facility #2
Rowan County Airport
P. O. Box 1786
Salisbury, NC 28145-1786

AASFC: LTC Robert L. Sides
ATTN: AASF-RUG
C: 704-359-5812; DSN: 583-9192
xdy98@nc-ngnet.army.mil

NORTH DAKOTA Bismarck

Office, Adjutant General, North Dakota ARNG
Fraire Barracks
P.O. Box 5511
Bismarck, ND 58502-5511



TAG:
MG Keith D. Bjerke
ATTN: AGND-Z
C: 701-224-5102
DSN: 344-5102
bjerkekd@nd-arng.ngb-army.mil

Office, State Army Aviation Officer, North Dakota ARNG
Army Aviation Support Facility
P.O. Box 5511
Bismarck, ND 58502-5511

SAAO:
LTC Fred A. Karnik
ATTN: AGND-DAVN-Z
C: 701-224-5908
DSN: 344-5908
davnd@nd-arng.ngb.army.mil

North Dakota Army National Guard Army Aviation Support Facility
P. O. Box 5511
Bismarck, ND 58506-5511
AASFC: LTC Gerald M. Heinle
ATTN: AGND-DAVN-ZA
C: 701-224-5160; DSN: 344-5160
aasfnd@nd-arng.ngb.army.mil

OHIO Columbus

Office, State Adjutant General, Ohio Army National Guard
2825 West Dublin Granville Rd.
Columbus, OH 43235-2789
TAG: MG Richard C. Alexander

Office, State Army Aviation Officer, Ohio Army National Guard
The Adjutant General's Dept.
2825 West Dublin Granville Rd.
Columbus, OH 43235-2789
SAAO: COL Craig T. Ceneskie
ATTN: AGOH-AV
C: 614-336-7067; DSN: 273-7067
saoo@oh-arng.ngb.army.mil

Ohio Army National Guard Aviation Support Facility #2
8140 S. Access Road
Bldg. 918
Columbus, OH 43217-5918
AASFC: LTC Rick D. Hall
C: 614-492-3000
aasf2oh@oh-arng.ngb.army.mil

3-137 Assault Helicopter Battalion
Building 920
Rickenbacker Airport
Columbus, OH 43217-5920
Commander: LTC Chris A. Coy
ATTN: AGOH-TAHB-Z
C: 614-492-3047
Executive Officer: MAJ Larry A. Hart
ATTN: AGOH-TAHB-XO
C: 614-492-3047
ASO: CW4 Bill Ashton
ATTN: AGOH-TAHB-SA
C: 614-492-3760; DSN: 950-3760
Senior NCO: CSM Phil Neal
ATTN: AGOH-AO-CSM
C: 614-492-3049

North Canton

Ohio Army National Guard Aviation Support Facility #1
5989 Airport Drive NW
North Canton, OH 44720-1483
AASFC: COL Thomas P. Luczynski
ATTN: AASF#1
C: 330-336-6101
aasf1oh@oh-arng.ngb.army.mil
Maintenance Officer: CW4 Clarence R. Carpenter
ATTN: AASF#1
C: 330-336-6121

OKLAHOMA Fort Sill

Henry Post Army Airfield
Fort Sill, OK 73503-5100
Airfield Manager: Mr. Randy C. Palmer
ATTN: ATZR-TFA
C: 580-442-4643; DSN: 639-4643
palmerr@doimex1.sill.army.mil

Lexington

Oklahoma Army National Guard Aviation Support Facility #1
Highway 39 East & 144th Avenue
Lexington, OK 73051-9549
AASFC: LTC Jackie L. Self
ATTN: OKAASF-LEX
C: 405-527-5601; DSN: 940-3260

Norman

Oklahoma Army National Guard Fixed Wing Operations
Max Westheimer Airport
2232 Goddard Avenue
Norman, OK 73069-8466
C: 405-360-1281; DSN: 940-3575

Oklahoma City

Office, State Adjutant General, Oklahoma Army National Guard
3501 Military Circle
Oklahoma City, OK 73111-4398



TAG:
MG Stephen P. Cortright
ATTN: OKTAG
C: 405-425-8201
DSN: 940-3201
CortrightS@ok-tbird.ngb.army.mil

Office, State Army Aviation Officer, Oklahoma Army National Guard
3501 Military Circle
Oklahoma City, OK 73111-4398

State Army Aviation Officer:
COL Leroy A. Wall
ATTN: OKSAO
C: 405-425-8282
DSN: 940-3294
wall@ok-tbird.ngb.army.mil

Tulsa

Tulsa Army National Guard Aviation Support Facility #2
4242 N. Mingo Valley
Tulsa, OK 74116-5200
C: 918-835-8911; DSN 956-5330

OREGON Pendleton

Oregon Army National Guard Army Aviation Support Facility #2
4529 NW "A" Street
Pendleton Airfield
Pendleton, OR 97801
Commander: MAJ Tim Kelly
C: 541-276-4544
aafs2@or-ngnet.army.mil

Salem

**Office, State Adjutant General,
Oregon Army National Guard**
P. O. Box 14350
Salem, OR 97309-5047



TAG:
MG Raymond E. Rees
ATTN: TAG
C: 503-945-3991
DSN: 355-3991
reesf@or-ngnet.army.mil

**Office, State Army Aviation Officer,
Oregon Army National Guard
Army Aviation Support Facility #1**
McNary Field
1921 Turner Road, SE
Salem, OR 97302-2099
SAAO: LTC Ben Gerding
C: 503-945-3217; DSN: 355-3993

Oregon Army National Guard Army Aviation Support Facility #1
1921 Turner Road SE
Salem, OR 97302
Commander: CPT Todd E. Farmer
C: 503-945-3310; DSN: 355-3310

PENNSYLVANIA Annville

Det 1, 198th Medical Company (AA)
Bldg 19-119 FTIG
Annville, PA 17003-5002

2-104th Aviation Battalion (GSAB)
Building 19-119
Fort Indiantown Gap
Annville, PA 17003-5002
Commander: MAJ(P) Paul DeVincenzo
ATTN: AVGS-CDR
C: 717-861-8251; DSN: 491-8251
uasaa@redrose.net
Senior NCO: CSM Patrick Shipe
ATTN: AVGS-CSM
C: 717-861-8251; DSN: 491-8251

**28th Infantry Division Aviation
Brigade, Pennsylvania ARNG**
Building 19-119
Fort Indiantown Gap
Annville, PA 17003-5002



Commander:
COL Jessica L. Wright
ATTN: TDAV-CDR
C: 717-861-8251
DSN: 491-8251

Executive Officer: LTC Barney Pultz
ATTN: TDAV-XO
C: 717-861-8251; DSN: 491-8251
ASO: CW5 Reed M. Zellers
ATTN: TDAV-ASO
C: 717-861-8922; DSN: 491-8922



Senior NCO:
CSM Robert E. Curran
ATTN: TDAV-CSM
C: 717-861-8252
DSN: 491-8252

**Eastern Army National Guard
Aviation Training Site (EAATS)
Department of Military Affairs**
Annville, PA 17003-5004



Commander:
LTC James G. Pierce
ATTN: EAATS-HQ-C
C: 717-861-8864
DSN: 491-8864
piercejg@pa-armg.ngb.army.mil

Deputy Commander: LTC Peter D. Anzulewicz
ATTN: EAATS-HQ-DC
C: 717-861-8878; DSN: 491-8878



Senior NCO:
CSM Kenneth R. Jacoby
ATTN: EAATS-HQ-CSM
C: 717-861-8795
DSN: 491-8795
jacobykr@pa-armg.ngb.army.mil

**Office, State Adjutant General,
Pennsylvania ARNG
Department of Military Affairs**
Annville, PA 17003-5002



TAG:
MG James W. Mac Vay
C: 717-861-8500
DSN: 491-8500

**Office, State Army Aviation Officer,
Pennsylvania ARNG
The Adjutant General of PA
Dept of Mil. & Vet. Affairs**
Fort Indiantown Gap
Annville, PA 17003-5002

SAAO:
COL Jessica L. Wright
ATTN: TAGPA-SAAO
C: 717-861-8825
DSN: 491-8825
saopa@pa-armg.ngb.army.mil

**Pennsylvania Army National Guard
Army Aviation Support Facility #1
Department of Military Affairs**
Annville, PA 17003-5005
AASFC: LTC Christopher Latchford
ATTN: AASF-FTIG
C: 717-861-8924; DSN: 491-8924
aasf1pa@pa-armg.ngb.army.mil

Horsham

**2d Battalion, 228th Aviation
Regiment**
936 Easton Road
Horsham, PA 19044
Commander: Vacant
ATTN: AFRC-AVIL-FQ
C: 215-957-0523
Senior NCO: Vacant
ATTN: AFRC-AVIL-FQ
C: 215-957-0523

Johnstown

**Pennsylvania Army National Guard
Army Aviation Support Facility #2**
292 Aviation Drive
Johnstown, PA 15902-7201
AASFC: LTC Dan Berkebile
C: 814-532-7725
aasf2jst@surfshop.net
Operations Officer: CW4 William A. Johns
C: 814-532-7717
aasf2jst@surfshop.net
Maintenance Officer: LTC Barney Pultz
C: 814-532-7723
aasfsjst@surfshop.net

Philadelphia

**Defense Contract Management
Command, Boeing Philadelphia**
P. O. Box 16859, MS P23-50
Philadelphia, PA 19142-0859
Commander: LTC Anthony D. Bell
ATTN: DCMDE-RED
C: 610-591-8500; DSN: 444-2585
bre0362@dcmde.dla.mil
Chief, Flight Operations Group: MAJ Charles F. Stroup, Jr.
ATTN: DCMDE-REDF
C: 610-591-3030; DSN: 444-4554
bre5929@dcmde.dla.mil

PUERTO RICO San Juan

**Office, State Adjutant General,
Puerto Rico ARNG**
P. O. Box 3786
San Juan, PR 00902-3786



TAG:
MG Emilio Diaz-Colon
ATTN: PR-TAG
C: 787-724-1295
tagpr@pr-armg.ngb.army.mil

**Office, State Army Aviation Officer,
Puerto Rico ARNG
Army Aviation Support Facility**
P.O. Box 3786
San Juan, PR 00902-3786



SAAO:
COL Jose F. Campos
ATTN: SAAO-PRARNG
C: 787-722-3916
DSN: 740-3279
saopr@pr-armg.ngb.army.mil

**Puerto Rico Army National Guard
Army Aviation Support Facility**
P. O. Box 3786
San Juan, PR 00902-3786

RHODE ISLAND Cranston

**Office, State Adjutant General,
Rhode Island ARNG
Command Readiness Center**
645 New London Avenue
Cranston, RI 02920-3097
TAG: MG Reginald A. Centracchio
ATTN: TAGRI
C: 401-457-4102; DSN: 557-3102
tagri@ri-ngnet.army.mil

**Office, State Army Aviation Officer,
Rhode Island ARNG
Command Readiness Center**
645 New London Avenue
Cranston, RI 02920



SAAO:
COL William H. Pond
ATTN: TAGRI-SAO
C: 401-457-4297
DSN: 557-3297
saori@ri-armg.ngb.army.mil

North Kingston

**Rhode Island ARNG Army Aviation
Support Facility**
Hangar 2, 104 Airport Street
Davisville Industrial Park
North Kingston, RI 02852-7516
AASFC: COL Alexander M. Lindsay
ATTN: AASF-FC
C: 401-621-5400; DSN: 557-3400
aasf2ri@ri-armg.ngb.army.mil

SOUTH CAROLINA Columbia

**Office, State Adjutant General, South
Carolina ARNG**
1 National Guard Road
Columbia, SC 29201-4766



TAG:
MG Stanhope Spears
ATTN: TAG
C: 803-806-4217
DSN: 583-4217
tagsc@sc-ngnet.army.mil

**Office, State Army Aviation Officer,
South Carolina ARNG
Office of the Adjutant General**
1 National Guard Road
Columbia, SC 29201-4766
SAAO: LTC Lester D. Eisner
ATTN: TAG-AV
C: 803-806-4335; DSN: 583-4335
saosc@sc-arng.ngb.army.mil

Eastover

**South Carolina Army National Guard
Army Aviation Support Facility**
1325 South Carolina Road
Suite 41
Eastover, SC 29044-5041
Commander: LTC Earl M. Yerrick
803-776-7030; DSN: 583-8298
aasf1sc@sc-arng.ngb.army.mil

**1/151 Aviation (Advanced Attack
Helicopter)**
10311 Garners Ferry Rd.
Eastover, SC 29044

Commander: LTC Earl M. Yerrick, Jr.
C: 803-806-1717
Senior NCO: CSM George E. Dorr
C: 803-806-1717

SOUTH DAKOTA Rapid City

1085th Medical Company
4750 Guard Road
Rapid City, SD 57701-8708
Commander: MAJ Kit Cline
C: 605-399-6390; DSN: 747-8390
kabrudk@smtp-sdngb.army.mil

**Office, State Adjutant General, South
Dakota ARNG**
2823 West Main Street
Rapid City, SD 57702-8186
TAG: MG Philip G. Killey
ATTN: SDTAG
C: 605-399-6702; DSN: 747-8702
killey@sd-arng.ngb.army.mil

**Office, State Army Aviation Officer,
South Dakota ARNG**
AASF, Rapid City Regional Airport
4750 Guard Road
Rapid City, SD 57701-8708
SAAO: COL Roger D. Dubs
ATTN: SDSAO
C: 605-399-6370; DSN: 747-8370
saosd@sd-arng.ngb.army.mil

**South Dakota Army National Guard
Army Aviation Support Facility**
Regional Airport
4750 Guard Road
Rapid City, SD 57701-8708
AASFC: COL Roger D. Dubs
ATTN: SDSAO
C: 605-399-6370; DSN: 747-8394
aasf1sd@sd-arng.ngb.army.mil

TENNESSEE Chattanooga

**Tennessee Army National Guard
Aviation Support Facility 3**
5900 Lovell Field Loop
Chattanooga, TN 37421-2163
AASFC: MAJ Gregory A. Castleberry
C: 423-634-6018

Jackson

**Tennessee ARNG Limited Army
Aviation Support Facility #4 (LAASF)**
McKellar-Sipes Regional Arpt.
2254 Westover Road
Jackson, TN 38301-9642
AASFC: LTC Ronald K. Herrington
ATTN: AGTN-AA4
C: 901-426-0581

Louisville

**Tennessee Army National Guard
Aviation Support Facility #2**
2111 Army Drive
Louisville, TN 37777-6300
AASFC: LTC Terry A. Ethridge
ATTN: AASF #2
C: 423-985-4601; DSN: 266-4601

Nashville

**Office, State Adjutant General,
Tennessee ARNG**
P. O. Box 41502
Nashville, TN 37204-1501



TAG:
MG Jackie D. Wood
ATTN: AGTN-AG
C: 615-313-3001
DSN: 683-3001
tag@tn-
arng.ngb.army.mil

**Office, State Army Aviation Officer,
Tennessee ARNG
National Guard Center**
Sidco Drive, CGTN-DOA
Nashville, TN 37204-1501
SAAO: COL Larry B. Shelton
ATTN: AGTN-DOA
C: 615-313-3051; DSN: 266-3051
saotn@tn-arng.ngb.army.mil

Smyrna

**Tennessee Army National Guard
Aviation Support Facility #1**
Building 680, Smyrna Airport
Smyrna, TN 37167-2091
AASFC: LTC Bill R. Hartbarger
ATTN: AGTN-AA1
C: 615-355-3612; DSN: 683-3612

TEXAS Austin

**49th Armored Division Aviation
Brigade**
2001 E. 51st Street
Austin, TX 78723-3097
Commander: COL Gerard B. Nery, Jr.
ATTN: ARDV-HZ
C: 512-465-5030; DSN: 954-5030
g-nery@ti.com
Senior NCO: CSM Patrick Hogan
ATTN: ARDV-HC-SM
C: 512-465-5030; DSN: 954-030
Patrick.Hogan@dir.state.tx.us
FTUS NCO: LTC Ted F. Strahan
ATTN: ARDV-HX
C: 512-465-5029; DSN: 954-5029
TedF5048@aol.com

49th Armored Division Aviation Brigade, HHC

2001 E. 51st Street
Austin, TX 78723-3097
Commander: CPT Stephen Bowers
ATTN: ARDV-HZ
C: 512-465-5289; DSN: 954-5289
Showers511@aol.com
Senior NCO: 1SG Robert S. Sebesta
C: 512-465-5289; DSN: 954-5289
FTUS NCO: SFC Johnny Stokes
C: 512-465-5289; DSN: 954-5289

49th Armored Division Aviation Brigade, Company F, 149th Aviation

2001 E. 51st Street
Austin, TX 78723-3097
Commander: MAJ Jeanne Buschow
ATTN: ARDV-FHZ
C: 512-465-5013; DSN: 954-5013
buschowj@aol.com
Senior NCO: 1SG Larry D. Becker
C: 512-465-5013; DSN: 954-5013
EM: Krisb@tenet.edu
FTUS NCO: SSG Vincent Kruger
C: 512-465-5013; DSN: 954-5013

Office, State Adjutant General, Texas Army National Guard

P. O. Box 5218
Austin, TX 78763-5218



TAG:
BG Daniel James III
ATTN: AGTK-A
C: 512-465-5006
DSN: 954-5006

**Office, State Army Aviation Officer,
Texas Army National Guard
Office of the Adjutant General**
P.O. Box 5218
Austin, TX 78763-5218



SAAO:
COL James B.
Looney
ATTN: AGTX-AV
C: 512-465-5167
DSN: 954-5167
saotx@tx-
arng.ngb.army.mil

Texas Army National Guard Aviation Support Facility #1

2001 East 51st Street
Austin, TX 78723-3097
AAASF: LTC John F. Stoley
ATTN: AAASF
C: 512-465-5088; DSN: 954-5088
jfstoley@aol.com

Conroe

7th Squadron, 6th Cavalry Regiment (ATKHB)

4724 South Parkway
Conroe, TX 77303-4355
Commander:
LTC Charles E. Fletcher
ATTN: AFRC-AVIL-AQ-CO
C: 409-525-3399

Executive Officer: MAJ Paul
Belobrajdic
ATTN: AFRC-AVIL-AQ-XO
C: 409-525-3443
belobrajdp@hood-ernh3.army.mil
S-3: MAJ Ron Dupree
ATTN: AFRC-AVIL-AQ-OP
C: 409-525-3392
dupreer@hood-ernh3.army.mil
SIP: CW4 Phil Houston
ATTN: AFRC-AVIL-AQ-SP
C: 409-525-3323
ASO: CW3 Robert E. Schultz
ATTN: AFRC-AVIL-AQ-AS
C: 409-525-3365



Senior NCO:
CSM Schiffrman
ATTN: AFRC-AVIL-
AQ
C: 409-525-3327
tjijm@juno.com

Corpus Christi

Corpus Christi Army Depot (CCAD)
308 Crecy Street, Stop 11
Corpus Christi, TX 78419-5260



Commander:
COL Dennis A.
Williamson
ATTN: SIOCC-CO
C: 512-961-3771
DSN: 861-3771
dwilliam@ccad.
army.mil

Civilian Executive Assistant: Ms.
Norma San Miguel
ATTN: SIOCC-CX
C: 512-961-3771; DSN: 861-3771
nsanmigu@ccad.army.mil

Depot Operations Officer: Mr. Larry R.
Jobe
ATTN: SIOCC-CD
C: 512-961-3771; DSN: 861-3771
ljobe@ccad.army.mil

Director of Maintenance: Mr. Jerry D.
New

ATTN: SIOCC-MA
C: 512-961-3771; DSN: 861-3771
jnew@ccad.army.mil

Chief, Aircraft Production Division:
Mr. Joe Guzman
ATTN: SIOCC-MA-AP
C: 512-961-3552; DSN: 861-3552
jguzman@ccad.army.mil

**Chief, Components Production
Division:** Mr. Wayne McConley
ATTN: SIOCC-MA-CP
C: 512-961-3622; DSN: 861-3622
wmccconle@ccad.army.mil

**Chief, Power Train Production
Division:** Mr. Juan Dela Cruz
ATTN: SIOCC-MA-PT
C: 512-961-3561; DSN: 861-3561
jdlcruz@ccad.army.mil

Chief, Production Control Division:
Mr. Blaine W. Withers
ATTN: SIOCC-MA-PC
C: 512-961-4167; DSN: 861-4167
bwitthers@ccad.army.mil

Chief, Quality Assurance Division:
Mr. A. E. Wohlman, Jr.
ATTN: SIOCC-MA-QA
C: 512-961-3871; DSN: 861-3871
awohlma@ccad.army.mil

Fort Bliss

**Biggs Army Airfield
Garrison Command**
1733 Pleasonton Road
Fort Bliss, TX 79916-6816

Commander: CPT Timothy A. Basham
ATTN: ATZC-GC-AV
C: 915-568-8242; DSN: 978-8242
bashamt@emh10.bliss.army.mil

Fort Hood

Fort Hood Regional Flight Center
Fort Hood, TX 76544

Commander: MAJ Jody E. Naron
ATTN: OSAC-TX
C: 254-288-9686; DSN: 738-3750
naronj@hood-emh3.army.mil

III Corps Aviation Office
Fort Hood, TX 76544-5056

III Corps Aviation Officer: COL
Nathan W. Noyes
ATTN: AFVU-AH
C: 254-288-2300; DSN: 738-2300
NoyesN@Hood-emh3.army.mil

**4th Brigade (Avn), 4th Infantry
Division (MECH)**
Fort Hood, TX 76544



Commander:
COL Craig K. Madden
ATTN: AFZC-AV-CO
C: 254-287-4094
DSN: 737-4094
maddenc@hood-emh3.army.mil

Senior NCO: CSM Frank Hill
ATTN: AFVB-A-CSM
C: 254-287-4774; DSN: 737-4774

**1st Squadron, 10th Cavalry
4th Aviation Brigade
4th Infantry Division (Mech)**
Fort Hood, TX 76544-5200

Commander: LTC Joseph A. Moore, Jr.
C: 254-288-7799; DSN: 737-7799
moorej@hood-emh3.army.mil

Executive Officer: MAJ Michael Senters
ATTN: HQ1-10CAV-SXO
C: 254-288-5806; DSN: 738-5806
senterism@hood-emh3.army.mil

Senior NCO: CSM George A. V. Bosley
ATTN: HQ1-10CAV-CSM
C: 254-288-7952; DSN: 738-7952
bosleyg@hood-emh3.army.mil

**1st Attack Battalion, 4th Aviation
Regiment
4th Infantry Division (Mech)**
Fort Hood, TX 76544-5200



Commander:
LTC Dyfied A. Harris
ATTN: AFZC-AVA-CO
C: 254-287-2364
DSN: 737-2364
14avnbnccdr@hood-emh3.army.mil

Executive Officer: MAJ Robert Hurne
ATTN: AFZC-AVA-XO
C: 254-287-2381; DSN: 737-2381
14avnbnxo@hood-emh3.army.mil

SIP: CW4 Claudio R. Facundo
ATTN: AFZC-AVA-SP
C: 254-288-3256; DSN: 738-3256
14avnstandards@hood-emh3.army.mil

ASO: CW4 Ed Petrow
ATTN: AFZC-AVA-SAF
C: 254-287-3710; DSN: 737-3710
petrowe@hood-emh3.army.mil

MTFE: CW4 Alan Ruzicka
ATTN: AFZC-AVA-D
C: 254-287-4638; DSN: 737-4638
14avnacdr@hood-emh3.army.mil



Senior NCO:
CSM Karl M. Moody
ATTN: AFZC-AVA-
CSM
C: 254-287-2426
DSN: 737-2426
moodyk@hood-emh3.army.mil

**2nd Battalion, 4th Aviation Regiment
4th Infantry Division (Mech)**
Fort Hood, TX 76544-5200

Commander: LTC Daniel J. Shanahan
C: 254-288-3087; DSN: 738-3087

Executive Officer: MAJ Rob Foutz
C: 254-288-3162; DSN: 738-3162

SIP: CW3 Kirk O'Donnell
C: 254-287-4424; DSN: 737-4424

ASO: CW4 Richard Taylor
C: 254-287-7080; DSN: 737-7080

**404th Support Battalion (Aviation)
4th Infantry Division (MECH)**
Fort Hood, TX 76544

Commander: LTC Michael C. Sevcik
ATTN: AFZC-SSC-CDR
C: 254-288-3502; DSN: 738-3502
sevcikm@hood-emh3.army.mil

**4th Brigade (Avn), 1st Cavalry
Division**
Fort Hood, TX 76545



**Brigade
Commander:**
COL Reed Kowalczyk
ATTN: AFVA-4BDE-
CDR
C: 254-287-4253
DSN: 737-4253
kowalczykr@hood-emh3.army.mil

Executive Officer: LTC Michael P.
Courts
ATTN: AFVA-4BDE-XO
C: 254-287-4793; DSN: 737-4793
courtsm@hood-emh3.army.mil

SIP: CW5 Tom Potter
ATTN: AFVA-4BDE-SIP
C: 254-288-1006; DSN: 738-1006
pottert@hood-emh3.army.mil

ASO: CW5 Gary W. Norton
ATTN: AFVA-4BDE-ASO
C: 254-288-1005; DSN: 738-1005
nortong@hood-emh3.army.mil

MTFE: CW5 Marvin T. Humble
ATTN: AFVA-4BDE-MTFE
C: 254-288-7284; DSN: 737-7284
humblem@hood-emh3.army.mil



S-3: CPT Paul Cooke
ATTN: AFVA-4BDE-S3
C: 254-287-4442; DSN: 737-4442
cookep@hood-emh3.army.mil

**1st Battalion, 227th Aviation
Regiment
4th Brigade
1st Cavalry Division**
Fort Hood, TX 76545



Commander:
LTC Michael N. Riley
ATTN: AFVA-4BDE-1-
227-CO
C: 254-287-1618
DSN: 737-1618
RILEYM@hood-emh3.army.mil

Executive Officer: MAJ Chuck Harrison
ATTN: AFVA-4BDE-1-227-XO
C: 254-287-1619; DSN: 737-1619
HarrisonC@hood-emh3.army.mil

SIP: CW4 Timothy R. Mitcham
ATTN: AFVA-4BDE-1-227-XO
C: 254-288-9087; DSN: 738-9087
MitchamT@hood-emh3.army.mil

ASO: CW4 Bob Davis
ATTN: AFVA-4BDE-1-227-ASO
C: 254-288-9087; DSN: 738-9087
DavisR@hood-emh3.army.mil

MTFE: CW4 E. J. Mikeska
ATTN: AFVA-4BDE-1-227-MTFE
C: 254-288-9733; DSN: 738-9733



Senior NCO:
CSM Walter Beckman
ATTN: AFVA-4BDE-1-
227-CSM
C: 254-288-6754
DSN: 738-6754
beckmanw@hood-emh3.army.mil

**1st Squadron, Seventh Cavalry
1st Cav Aviation Brigade**
Fort Hood, TX 76545-5113

Commander: LTC Robert D. Nossov
ATTN: AFVA-CAB-1/7CAV-CDR
C: 254-287-2811; DSN: 737-2811

Executive Officer: MAJ Michael J. Karr
ATTN: AFVA-CAB-1/7CAV-XO
C: 254-287-4080; DSN: 737-4080

SIP: CW4 Richard Guy
ATTN: AFVA-CAB-1/7CAV-SIP
C: 254-288-1034; DSN: 738-1034

ASO: CW3 Tommy Stames
ATTN: AFVA-CAB-1/7CAV-ASO
C: 254-288-1036; DSN: 738-1036

MTFE: CW3 Floyd S. Werner, Jr.
C: 254-287-3945; DSN: 737-3945

Senior NCO: CSM Johnnie Lightsey
ATTN: AFVA-4BDE-1/7CAV-CSM
C: 254-287-6524; DSN: 737-6524
lightseyj@hood-emh3.army.mil

**2nd Battalion, 227th Aviation
Regiment**

**4th Brigade (Avn)
1st Cavalry Division**
Fort Hood, TX 76545

Commander: LTC Christine B.
Knighton
ATTN: AFVA-AB-2-227
C: 254-288-1022; DSN: 738-1022
knightonc@hood-emh3.army.mil

Executive Officer: MAJ Joseph M.
Kools

ATTN: AFVA-AB-2-227-XO
C: 254-288-1016; DSN: 738-1016
koolsj@hood-emh3.army.mil

SIP: CW3 Michael Wilson
ATTN: AFVA-AB-2-227-SIP
C: 254-288-1988; DSN: 738-1988

ASO: CW3 Randy Kirgiss
ATTN: AFVA-AB-2-227-SAFE
C: 254-288-9286; DSN: 738-9286
kirgissr@centraltx.net

MTFE: CW4 Melville E. Macie
ATTN: AFVA-AB-2-227-D
C: 254-288-2170; DSN: 738-2170

Senior NCO: CSM Jimmy G. Ruiz
ATTN: AFVA-AB-2-227-CSM
C: 254-288-1009; DSN: 254-738-1009
ruizj@hood-emh3.army.mil

**21st Cavalry Brigade (Air Combat)
III Corps and Fort Hood**
Fort Hood, TX 76544-5038



Commander:
COL Nathan W.
(Winn) Noyes
ATTN: AFVU-AH
C: 254-288-2301
DSN: 738-2301
noyesn@hood-emh3.army.mil

Deputy Brigade Commander: LTC
Richard E. MacNealy
ATTN: AFVU-AH
C: 254-288-2302; DSN: 738-2302
macnealyr@hood-emh3.army.mil

Executive Officer: LTC Wayne A.
Sauer
ATTN: AFVU-AH
C: 254-288-2302; DSN: 738-2302
sauerw@hood-emh3.army.mil

SIP: CW5 Robert J. Whatley
ATTN: AFVU-AH-T
C: 254-288-3575; DSN: 738-3575
whatleyr@hood-emh3.army.mil

ASO: CW4 David Kather
ATTN: AFVU-AH-T
C: 254-288-3825; DSN: 738-3825
katherd@hood-emh3.army.mil



Senior NCO:
CSM L. M. Morgan
ATTN: AFVU-AH
C: 254-288-2313
DSN: 738-2313
morganl@hood-emh3.army.mil

36th Medical Evacuation Battalion
Fort Hood, TX 76544-5076

Commander: LTC Dave(P) McCrady
ATTN: AFZG-MG-ME
C: 254-287-4113; DSN: 737-4113

507th Medical Company (Air Ambulance)
Fort Hood, TX 76544-5000
Commander: MAJ Jose A. Betancourt
ATTN: AFVG-MG-ME-ACO
C: 254-288-1436; DSN: 738-1436

Aviation Test Directorate, USATEX-COM
Fort Hood, TX 76544-5065



Director:
COL Robert T. Harmon
ATTN: CSTE-TEX-AV
C: 254-288-9992
DSN: 738-9992
harmonbob@texcom-mail.army.mil

Deputy Director: Mr. Harvey L. Elmore
ATTN: CSTE-TEX-AV
C: 254-288-1881; DSN: 738-1881
elmoreharvey@texcom-mail.army.mil

Directorate NCOIC/Senior Test NCO:
Master Sergeant Mark Ingram
ATTN: CSTE-TEX-AV
C: 254-288-9150; DSN: 738-9150
ingrammark@texcom-mail.army.mil

Aviation Systems Test Div., Aviation Test Directorate, USATEXCOM
Fort Hood, TX 76544



Division Chief:
Mr. David E. Boyken
ATTN: CSTE-TEX-AV-A
C: 254-288-9774
DSN: 738-9774
boykendave@texcom-mail.army.mil

Division NCOIC: SFC Jeff Marlow
ATTN: CSTE-TEX-AV-A
C: 254-288-9594; DSN: 738-9594
marlowjeff@texcom-mail.army.mil

Combat Aviation Test Div., Aviation Test Directorate, USATEXCOM
Fort Hood, TX 76544



Division Chief:
LTC John C. Donahue
ATTN: CSTE-TEX-AV-C
C: 254-288-1614
DSN: 738-1614
donahuejohn@texcom-mail.army.mil

Senior Military Test Plans Analyst:
Mr. Robert Strange
ATTN: CSTE-TEX-AV-C
C: 254-288-9213; DSN: 738-9213
strangerobert@texcom-mail.army.mil

Division NCOIC: Master Sergeant Della St. Louis
ATTN: CSTE-TEX-AV-C
C: 254-288-9830; DSN: 738-9830
slouisdella@texcom_mail.army.mil

Fort Sam Houston

Aviation Office, U.S. Army Medical Command
Fort Sam Houston, TX 78234-6000

Aviation Staff Officer: MAJ Timothy J. Moore
ATTN: MCHO-OP-O
C: 210-221-7010; DSN: 471-7010
maj_timothy_moore@smtplink.medcom.amedd.army.mil

Aviation Division, Fifth U.S. Army
Fort Sam Houston, TX 78234-7000



Chief:
LTC Michael J. Hartman
ATTN: AFKB-TR-A
C: 210-221-2048
DSN: 471-2048
HARTMANM@SAMHOU-USAFAVE.ARMY.MIL

Operations Officer: MAJ Doreen Morris
ATTN: AFKB-TR-ADO
C: 210-221-9747; DSN: 471-9747
morrisd@samhou-usafive.army.mil
Operations NCOIC: Master Sergeant Carol Geisler
ATTN: AFKB-TR-ADO
C: 210-221-0843; DSN: 471-2837
geislerc@samhou-usafive.army.mil

Aviation Logistics: Mr. Roland Ward
ATTN: AFKB-TR-ADO
C: 210-22-0244; DSN: 471-0244
ward@samhou-usafive.army.mil

Secretary: Ms. Margie Forsberg
ATTN: AFKB-TR-A
C: 210-221-2032; DSN: 471-0244
forsbergm@samhou-usafive.army.mil

Aviation/Ground Safety, Fifth USA
Fort Sam Houston, TX 78234-7000
Safety Manager: Mr. John L. Little
ATTN: AFKB-TR-S
C: 210-221-0410; DSN: 471-0410
littlej@samhou-usafive.army.mil

Fort Worth

Defense Contract Management Command, Bell Helicopter Textron
P.O. Box 1605
Fort Worth, TX 76101-1605
Commander: COL Barney A. Grimes III
ATTN: DCMDW-RKD
C: 817-280-7015; DSN: 477-7015

Grand Prairie

Texas Army National Guard Aviation Support Facility #3
1009 Lakecrest Drive
Grand Prairie, TX 75051-3497

AASFC: MAJ Wayne P. Sinibaldi
ATTN: DAASF-CDR
C: 972-266-6560; DSN: 874-6560

Houston

1st Battalion, 149th Aviation Regiment
Building 1182, Ellington ANGB
Houston, TX 77034-5596
Commander: LTC Gerald L. Ericsson
ATTN: ARDV-THZ
C: 281-929-2765; DSN: 954-2765

Senior NCO: CSM Hulen T. Riggsby III
ATTN: ARDV-THC-SM
C: 281-929-2765; DSN: 954-2765
HLRRP@aol.com
FTUS Officer: CPT Guy Schultz
ATTN: ARDV-THX
C: 281-929-2765; DSN: 954-2765
guysch@aol.com
ASO: CW4 Donald Garnto
C: 713-484-6183; DSN: 954-2334

Texas Army National Guard Aviation Support Facility #4
1183 Ellington Field
Houston, TX 77034-5597
AASFC: LTC Jerry L. Ericsson
ATTN: HAASF
C: 281-929-2332; DSN: 954-2332

Mesquite

341st Medical Battalion (EVAC)
612 East Davis Street
Mesquite, TX 75149-4798
Commander: MAJ Anne M. Guevara
ATTN: AFRC-CAR-HM
C: 972-882-1525
71134,3023@compuserve.com

San Antonio

2nd Battalion, 149th Aviation Regiment
5500 IH 10 E
San Antonio, TX 78219-4599
Commander: LTC Hugh Shine
ATTN: ARDV-UHZ
C: 210-666-5429; DSN: 471-2919
hdshine@concentric.net
Senior NCO: CSM Benny Aleman, Jr.
ATTN: ARDV-UHC-SM
C: 512-465-5951; DSN: 954-5051
FTUS Officer: MAJ Jay Whitaker
ATTN: ARDV-UHX
C: 210-666-5429; DSN: 471-2919
ASO: CW4 Frank Perales
C: 210-611-3631; DSN: 471-2919

49th Armored Division Aviation Brigade, Company H, 149th Aviation
5500 IH 10 E
San Antonio, TX 78219-4599
Commander: CPT David L. Gray
ATTN: ARDV-BC
C: 512-250-6012
davegray@austin-web.com
Senior NCO: 1SG John F. Ranft
ATTN: ARDV-BC
C: 210-661-3111
FTUS NCO: SFC Richard Guerra
C: 210-661-3998; DSN: 487-1110
rguerra@freewwweb.com

Texas Army National Guard Aviation Support Facility #2
5500 IH 10 East
San Antonio, TX 78219-4599
AASFC: LTC Robert E. Landstrom
ATTN: SAAASF
C: 210-661-3631; DSN: 471-2919

Waco

1-124th Cavalry Squadron
2120 North New Road
Waco, TX 76707-1098
Commander: LTC George Conwill
ATTN: ARDV-CHZ
C: 254-776-1402
GSCAuston@aol.com

Senior NCO: CSM Monroe Kelinske
ATTN: ARDV-CHC-SM
C: 254-776-1402
CAV124CSM@aol.com
FTUS Officer: CPT Len Smith
ATTN: ARDV-CHP-A
C: 254-776-1402
Portia4736@aol.com
ASO: CW4 Donald Garnto
C: 713-484-6183; DSN: 954-2334

UTAH Draper

Office, State Adjutant General, Utah Army National Guard
12953 S. Minuteman Drive
Draper, UT 84020-1776



TAG:
MG James M. Miller
ATTN: TAG-UT
C: 801-523-4402
DSN: 766-3900
tagut@ut-ngnet.army.mil

Office, State Army Aviation Officer, Utah Army National Guard
P. O. Box 1776
Draper, UT 84020-1776
SAAO & Director of Aviation & Safety: LTC Curtis G. Whiteford
ATTN: UT-DOAS
C: 801-523-4418; DSN: 766-4418
saout@ut-armg.ngb.army.mil

West Jordan

Utah Army National Guard Army Aviation Support Facility
7563 South Airport Road
West Jordan, UT 84084-7812
Commander: MAJ Michael P. Jensen
ATTN: UT-DOAS-AASF
C: 801-816-3492; DSN: 766-3492
aasf1ut@ut-armg.ngb.army.mil

211th Aviation Group Utah Army National Guard
7602 South Airport Road
West Jordan, UT 84084-7812
Commander: COL Martin R. Taylor
ATTN: UT-211AV-GP
C: 801-816-3540; DSN: 766-3546
attack64@hotmail.com

VERMONT Colchester

Office, State Adjutant General, Vermont Army National Guard
Green Mountain Armory
Colchester, VT 05446-3004
TAG: MG Martha T. Rainville
ATTN: VT-AG
C: 802-654-0124; DSN: 636-3124

South Burlington

Office, State Army Aviation Officer, Vermont Army National Guard Army Aviation Support Facility
COL James D. Kneedland Flight Facility
Airguard Road
South Burlington, VT 05403-6097

SAAO: COL Thomas J. Shailor
ATTN: VT-AV
C: 802-654-0400; DSN: 636-3400
saovt@vt-arng.ngb.army.mil

Vermont Army National Guard Army Aviation Support Facility
COL James D. Kneeland Flight Facility
Airguard Road
South Burlington, VT 05403-6097

VIRGIN ISLANDS Christiansted

Office, State Adjutant General, Virgin Islands ARNG
4031 La Grande Princesse
Lot 1B
Christiansted, VI 00820



TAG:
MG Jean A. Romney
C: 809-712-7711

St. Croix

Office, State Army Aviation Officer, Virgin Islands ARNG
Aviation Operating Facility
P. O. Box 2270, Kingshill
St. Croix, VI 00851-2270



SAAO:
LTC Caroline F. Adams
ATTN: VI-AVN
C: 809-778-2165

Virgin Islands Army National Guard Army Aviation Operating Facility
P. O. Box 2270, Kingshill
St. Croix, VI 00851-2270

VIRGINIA Alexandria

U.S. Total Army Personnel Command (PERSCOM)
200 Stovall Street
Alexandria, VA 22332-0400



Commanding General:
MG Thomas W. Garrett
ATTN: TAPC-ZA
C: 703-325-8844
DSN: 221-8844

Senior NCO: CSM Charles L. Nunley
ATTN: TAPC-CSM
C: 703-325-8847; DSN: 221-8847

Warrant Officer Division, OPMD, TAPC
U.S. Total Army PERSCOM
200 Stovall Street
Alexandria, VA 22332-0420



Division Chief:
CW5 Max Owens
ATTN: TAPC-OPW
C: 703-325-5255
DSN: 221-5255
owensm@hoffman.army.mil

Leader Development Branch Chief:
CW5 Tom Penrose
ATTN: TAPC-OPW-D
C: 703-325-5254; DSN: 221-5254
penroset@hoffman.army.mil

Aviation Branch Chief: CW5 Dave Campbell
ATTN: TAPC-OPW-AV
C: 703-325-5224; DSN: 221-5224
campedo@hoffman.army.mil

AH-1 and AH-64 Career Manager:
CW4 Al Eggerton
ATTN: TAPC-OPW-AV
C: 703-325-5225; DSN: 221-5223
eggertoa@hoffman.army.mil

OH-58A/C/D/151A Career Manager:
CW4 Mike Trigger
ATTN: TAPC-OPW-AV
C: 703-325-5228; DSN: 221-5228
trigger1@hoffman.army.mil

Schools/Naval Test Pilots/153A: CW3 Randy Grunow
ATTN: TAPC-OPW-AV
C: 703-325-5251; DSN: 221-5251
grunowr@hoffman.army.mil

UH-60 Career Manager: CW4 George Gonsalves
ATTN: TAPC-OPW-AV
C: 703-325-5223; DSN: 221-5225
gonsalvg@hoffman-emh1.army.mil

CH-47/FW/AVN Career Manager: CW4 Al Coleman
ATTN: TAPC-OPW-AV
C: 703-325-5284; DSN: 221-5284
coleman1@hoffman.army.mil

Warrant Officer Flight Training Accessions Manager: Ms. Mary Ann Ashley
ATTN: TAPC-OPW-AV
C: 703-325-5283; DSN: 221-5283
ashleym@hoffman.army.mil

Aviation Personnel Technician: Ms. Molley Tucker
ATTN: TAPC-OPW-AV
C: 703-325-7836; DSN: 221-7836
tuckerm@hoffman.army.mil

Aviation Personnel Technician AH-64/CH-47: Mr. Clifton Aubrey
ATTN: TAPC-OPW-AV
C: 703-235-5226; DSN: 221-5226
aubreyc@hoffman.army.mil

Aviation Branch, OPMD, U.S. Total Army PERSCOM
200 Stovall Street
Alexandria, VA 22332-0400

Branch Chief: LTC Danny N. Cash
ATTN: TAPC-OPE-V
C: 703-325-2808; DSN: 221-2808
cashd@hoffman.army.mil

Colonel's Assignment Officer: LTC Robert W. Kline
ATTN: TAPC-OPE-V
C: 703-325-5633; DSN: 221-5633
kliner@hoffman.army.mil

Lieutenant Colonels' Assignment Officer: MAJ Louis P. Schurott
ATTN: TAPC-OPE-V
C: 703-325-6194; DSN: 221-6194
schurotl@hoffman.h1.army.mil

Lieutenant Colonel's Technician: Ms. Sandi Sanders
ATTN: TAPC-OPE-V
C: 703-325-2534; DSN: 221-2534
sanderso@hoffman.army.mil

Majors' Assignment Officer: MAJ Mike Reed
ATTN: TAPC-OPE-V
C: 703-325-5669; DSN: 221-5669
reedm@hoffman.army.mil

Majors' Assignment Officer: MAJ Mark L. Shelton
ATTN: TAPC-OPE-V
C: 703-325-6399; DSN: 221-6399
sheltonm@hoffman.army.mil

Captains' Assignment Officer: CPT John Lindsay
ATTN: TAPC-OPE-V
C: 703-325-6379; DSN: 221-6379
lindsayj@hoffman.army.mil

Captains' Assignment Officer: CPT Shannon B. Brown
ATTN: TAPC-OPE-V
C: 703-325-4384; DSN: 221-4384
browns3@hoffman.army.mil

Lieutenants' Assignment Officer:
CPT Allan G. Grines
ATTN: TAPC-OPE-V
C: 703-325-5974; DSN: 221-5974
grinesa@hoffman.army.mil

Future Readiness Officer: CPT John J. Lindsay
ATTN: TAPC-OPE-V
C: 703-325-5974; DSN: 221-5974
lindsayj@hoffman-emh1.army.mil

Accessions: Ms. Brenda Twyford
ATTN: TAPC-OPE-V
C: 703-325-6477; DSN: 221-6477
twyfordb@hoffman.army.mil

Aviation/Transportation Branch, EPMD, TAPC

US Total Army Personnel Cmd.
Hoffman Building
2461 Eisenhower Avenue
Alexandria, VA 22331-0414

Branch Chief: LTC(P) Gary K. Knapp
ATTN: TAPC-EPL-T
C: 703-325-3080; DSN: 221-3080
knappg@hoffman-emh1.army.mil

Branch SGM: SGM Mary A. Lewellyn
ATTN: TAPC-EPL-T
C: 703-325-3083; DSN: 221-3083
lewellynm@hoffman-emh1.army.mil

NCOIC, Enlisted Aviation Section:
Master Sergeant Wagdi Mabrouk
ATTN: TAPC-EPL-T
C: 703-325-5061; DSN: 221-5061
mabroukw@hoffman-emh1-army.mil

Professional Development NCO:
SSG Olivia E. Smith
ATTN: TAPC-EPL-T
C: 703-325-5659; DSN: 221-5659
smitho@pentagon-hqdadss.army.mil

Professional Development NCO: SFC Alan Sieber
ATTN: TAPC-EPL-T
C: 703-325-4598; DSN: 221-4598
siebera@hoffman-emh1.army.mil

Professional Development NCO: SFC Dwain E. Pannell
ATTN: TAPC-EPL-T
C: 703-325-4612; DSN: 221-4612
pannell@hoffman-emh1.army.mil

Professional Development NCO: SFC Andrew Cramer
ATTN: TAPC-EPL-T
C: 703-325-4554; DSN: 221-4554
cramera@hoffman-emh1.army.mil

Professional Development NCO: SFC Roger Curry
ATTN: TAPC-EPL-T
C: 703-325-4543; DSN: 221-4543
curryr@hoffman-emh1.army.mil

Training Manager: Mr. Steve Herrera
ATTN: TAPC-EPL-T
C: 703-325-4611; DSN: 221-4611
herreras@hoffman-emh1.army.mil

Aviation Management Branch, OPMD, TAPC
US Total Army Personnel Cmd.

200 Stovall Street
Alexandria, VA 22332-0413
Chief: MAJ Mike Reed
ATTN: TAPC-PLP-A, Room 3N43
C: 703-325-5098; DSN: 221-5098
ReedM@hoffman-emh1.army.mil

Non-Rated Crewmembers Pay: Ms. Shirley Mitchell
ATTN: TAPC-PLP-A
C: 703-325-4524; DSN: 221-4524

Avn Career Incentive Pay: Ms. Margie Brown
ATTN: TAPC-PLP-A
C: 703-325-8701; DSN: 221-8701
Medical Waivers/FEB AAPL: Mrs. Betty Scott
ATTN: TAPC-PLP-A
C: 703-325-8701; DSN: 221-6346

Special Management Division, TAPC
U.S. Total Army Personnel Cmd.
200 Stovall Street
Alexandria, VA 22332-0406

Chief, Special Management Division: LTC Thomas W. Wieckes
ATTN: TAPC-OPZ-SM
C: 703-325-8828; DSN: 221-8828
wieckest@hoffman-emh1.army.mil

Chief, Special Ops. Avn. Branch:
MAJ Samuel D. Torrey
ATTN: TAPC-OPZ-SM
C: 703-325-4042; DSN: 221-4042
torreys@hoffman-emh1.army.mil

Aviation Office, U.S. Army Materiel Command (USAMC)

5001 Eisenhower Avenue
Alexandria, VA 22333-0001
Aviation Officer: Mr. John A. Savelli
ATTN: AMCLG-RS (AVN)
C: 703-617-9891; DSN: 767-9891
jsavelli@alexandria-emh1.army.mil

Safety Office, U.S. Army Materiel Command (USAMC)

5001 Eisenhower Avenue
Alexandria, VA 22333-0001
Aviation Safety Manager & AT&A Officer: Mr. Loren Becker
ATTN: AMCSF-A
C: 703-617-5476; DSN: 767-5476
lbecker@hqamc.army.mil

Aviation Evaluation Directorate, U.S. Army OPTEC
4501 Ford Avenue
Alexandria, VA 22302-1458

Director: COL Albert P. Brocius
ATTN: CSTE-OEC-AVE
C: 703-681-9169; DSN: 761-9169
brociusalbert@hq.optec.army.mil

Deputy Director: Mr. Ralph A. Redmond
C: 702-681-9168; DSN: 761-9168
redmondralph@hq.optec.army.mil

Chief, Systems Evaluation Division:
LTC James A. Boland, Jr.
C: 703-681-9165; DSN: 761-9165
bolandjames@hq.optec.army.mil

Aviation Evaluation Officer (AMPS/AWE/A2C2S): MAJ Fred Campbell
C: 703-681-9162; DSN: 761-9162
campbellfrederick@hq.optec.army.mil

Aviation Evaluation Officer (SIIR-CM/UH-60A/L): MAJ John M. Howden
C: 703-681-9162; DSN: 761-9162
howdenjohn@hq.optec.army.mil

Aviation Evaluation Officer (SIRFC/ICH): MAJ Joe Trottie
C: 703-681-9162; DSN: 761-9162
trottiejoseph@hq.optec.army.mil

Aviation Evaluation Officer (Comanche/SOA): MAJ Don Scantlan
C: 703-681-9160; DSN: 761-9160
scantliandonald@hq.optec.army.mil

Aviation Evaluation Officer (DIV XXI/Kiowa Warrior): CPT(P) Gus Blum
C: 703-681-9160; DSN: 761-9160
blumgustavo@hq.optec.army.mil

Aviation Evaluation Officer (ICH/UH-60Q/AGSE): CPT Don Reedy
C: 703-681-9162; DSN: 761-9162
reedydonald@hq.optec.army.mil

Avn Eval. Ofr (RPA/Starstreak/Longbow/Hellfire II): CW4 Joe Tygart
C: 703-681-9160
tygartjoseph@hq.optec.army.mil

Sr. Research Development Test & Evaluation NCO: SFC Pat Geddes
C: 703-681-9162; DSN: 761-9162
geddespartrick@hq.optec.army.mil

Arlington

Office, Unmanned Aerial Vehicles Joint Project (UAV)
1213 Jefferson Davis Hwy.
Arlington, VA 22246

Logistics Division, OCAR
1815 N. Fort Myer Drive
Arlington, VA 22209-1808



Staff Logistics Officer - Aviation:
Mr. Rodger Nash
ATTN: DAAR-LO, Room 208
C: 703-696-5175
DSN: 226-5175
nash@ocar.army.pentagon.mil

Army Aviation & Safety Division, National Guard Bureau
ARNG Readiness Ctr.
111 South George Mason Drive
Arlington, VA 22204



Chief: COL Joseph L. Ferreira
ATTN: NGB-AVN
C: 703-607-7700
DSN: 327-7700
ferreirj@ngb-armg.ngb.army.mil

Executive Officer: CPT Michael Braun
ATTN: NGB-AVN
C: 703-607-7703; DSN: 327-7703
braunm@nbg-armg.ngb.army.mil

Aviation Systems Branch, Army Aviation & Safety Division, NGB
ARNG Readiness Ctr.
111 South George Mason Drive
Arlington, VA 22204-1382

Chief: Mr. Alberto J. Jimenez
ATTN: NGB-AVN-A
C: 703-607-7720; DSN: 327-7720

Aviation Opns. Branch, Army Avn. & Safety Div., NGB

ARNG Readiness Center
111 South George Mason Drive
Arlington, VA 22204-1382

Chief: LTC David C. Mackey
ATTN: NGB-AVN-O
C: 703-607-7710; DSN: 327-7710
mackeyd@ngb-armg.ngb.army.mil

Falls Church

Plans & Operations Div., Dir., of Health Care Operations, OTSG
5109 Leesburg Pike
Falls Church, VA 22041-3258

Aviation Staff Officer: MAJ(P) Patrick Wilson
Room 691, ATTN: DASG-HCO
C: 703-681-6497; DSN: 761-6497
maj_patrick_wilson@OTSG-AMEDD.army.mil

Fort Belvoir

Office PM, Night Vision/RSTA
10221 Burbeck Road
Suite 430
Fort Belvoir, VA 22060-5806

Project Manager: COL Jeffrey A. Sorenson
ATTN: SFAE-IEW&S-NV
C: 703-704-3450; DSN: 654-3450
jsorenson@nvl.army.mil

Deputy Project Manager: Mr. John R. Gresham
ATTN: SFAE-IEW&S-NV
C: 703-704-3444; DSN: 354-3444
jgresham@nvl.army.mil

Technical Director & Chief of Technology Division: Mr. Mack R. Farr
ATTN: SFAE-IEW&S-NV
C: 703-704-3493; DSN: 654-3493
mfarr@nvl.army.mil

Product Manager, FLIR: LTC Curtis McCoy
ATTN: SFAE-IEW&S-NV
C: 703-704-1192; DSN: 654-1192
cmccoy@nvl.army.mil

U.S. Army Aeronautical Services Agency

9325 Gunston Road
Fort Belvoir, VA 22060-5582

Director: COL Charles H. Dove
ATTN: MOAS-ZA
C: 703-806-4862; DSN: 656-4862
charles_h_dove@belvoir.army.mil

Office, State Army Aviation Officer, District of Columbia ARNG

Army Aviation Support Facility
Davison Army Airfield
Fort Belvoir, VA 22060-5726
SAAO: COL Michael P. Breithaupt
ATTN: DCARNG-SAO
C: 703-806-7691; DSN: 656-7691

District of Columbia ARNG Army Aviation Support Facility

Davison Army Airfield
7000 Britten Drive
Fort Belvoir, VA 22060-5106
AAFSC: COL Michael P. Breithaupt
ATTN: DCARNG-SAO
C: 703-806-7691; DSN: 656-7691

Operational Support Airlift Agency (OSAA)

6970 Britten Drive, Suite 201
Fort Belvoir, VA 22060-5133



Commander:
COL Arthur J. Sosa
ATTN: OSAA-CD
C: 703-806-7008
DSN: 656-7008
sosaa@osaa-armg.belvoir.army.mil

Deputy Commander: LTC Eric C. Peck
ATTN: OSAA-DC
C: 703-806-7016; DSN: 656-7016
pecke@osaa-armg.belvoir.army.mil



Senior NCO:
CSM Robert A. Oram
ATTN: OSAC-CSM
C: 703-806-7114
DSN: 656-7114

Fort Belvoir Regional Flight Center

6970 Britten Drive, Suite 201
Davison AAF
Fort Belvoir, VA 22060
Commander: MAJ Everett R. Medlin II
C: 703-806-7320
medline@amgrc-emh-2.army.mil

12th Aviation Battalion

8926 Gavin Road, Suite 201
Fort Belvoir, VA 22060-5123



Commander:
LTC Lavern Young, Jr.
ATTN: ANAV-CB
C: 703-806-7578
DSN: 656-7578
youngl@belvoir.airfield.army.mil

S-3: MAJ Robert Quackenbush
ATTN: ANAV-CBO
C: 703-806-7608; DSN: 656-7608

SIP: CW5 William H. Blamey
ATTN: ANAV-CBR
C: 703-806-7062; DSN: 656-7062

Aircraft Maintenance Officer: CPT James H. Clingham
ATTN: ANAV-CBD
C: 703-806-7647; DSN: 656-7647

Safety Officer: CW4 William L. Huszar
ATTN: ANAV-CBT
C: 703-806-7436; DSN: 656-7436



Senior NCO:
CSM Lawrence Owens
ATTN: ANAV-CBM
C: 703-806-7311
DSN: 656-7311

Fort Eustis

5th Battalion, 159th Aviation Regiment

Building 1706
Fort Eustis, VA 23604-5594
Commander: LTC Matthew S. Maney
ATTN: AFRC-AVIL-EQ
C: 804-765-0701
Senior NCO: CSM Donald L. Powers
ATTN: AFRC-AVIL-EQ
C: 202-482-3341
dpowers@doc.gov

U.S. Army Aviation Logistics School (USAALS)

Building 2717
Fort Eustis, VA 23604

Assistant Commandant: COL Louis A. Bonham
ATTN: ATSQ-LAC
C: 757-878-6847; DSN: 927-6847
bonhaml@eustis.army.mil

Deputy Assistant Commandant: Mr. Rodney J. Schulz
ATTN: ATSQ-LAC
C: 757-878-6805; DSN: 927-6805
schulzr@eustis-emh10.army.mil

Sergeant Major: SGM Esquire McCoy
ATTN: ATSQ-LAC
C: 757-878-6809; DSN: 927-6809
mccoye@eustis.army.mil

Aviation Logistics and Integration Planning Group, USAALS
Fort Eustis, VA 23604

Department of Attack Helicopter Training, USAALS

Fort Eustis, VA 23604-5415
Director: CW5 Wayne A. Waersch
ATTN: ATSQ-LAC-H
C: 804-878-4564; DSN: 927-4564
Senior NCO: SGM Russell W. Jordan
ATTN: ATSQ-LAC-H
C: 804-878-4564; DSN: 927-4564

Department of Aviation Systems Training, USAALS

Fort Eustis, VA 23604

Director: LTC Rich Enderle
ATTN: ATSQ-LTD-S
C: 804-878-5405; DSN: 927-5405
EM: enderler@eustis-emh10.army.mil
Senior NCO: SGM John Weber
ATTN: ATSQ-LTD-S
C: 804-878-4469; DSN: 927-4469
weberj@eustis-emh10.army.mil

**Department of Aviation Trades
Training, USAALS
U.S. Army Aviation
Logistics School**

Fort Eustis, VA 23604

Director: LTC A.E. Matthewson, Jr.
ATTN: ATSQ-LAC-T
C: 757-878-5039; DSN: 927-5039
Senior NCO: SGM Earl Hildebran, Jr.
ATTN: ATSQ-LAC-T
C: 757-878-3556; DSN: 927-3556

**Directorate of Training, Plans and
Evaluation, USAALS**

Fort Eustis, VA 23604-5421

Director: LTC Paul J. Myers
ATTN: ATSQ-LAC-P
C: 804-878-6601; DSN: 927-6601
myersp@eustis-emh1.army.mil
Deputy Director: Mr. William H. Zinn
ATTN: ATSQ-LAC-P
C: 804-878-6601; DSN: 927-6601
Senior NCO: CSM Jimmie L. Taylor
ATTN: ATSQ-LAC-P
C: 804-878-6601; DSN: 927-6601

**1st Battalion, 222nd Aviation
Regiment**

8th Transportation Brigade

Fort Eustis, VA 23604

Commander: LTC Mark C. Bingham
ATTN: ATSP-BDF
C: 757-878-2867; DSN: 927-2867
bingamanm@eustis.army.mil
Executive Officer: MAJ Kyle Woodard
Ray
ATTN: ATSP-BDF
C: 757-878-2724; DSN: 927-2867
rayk@eustis.army.mil



Senior NCO:
CSM James A. Marshall
ATTN: ATSP-BDF
C: 757-878-2724
DSN: 927-2724
marshallj@eustis.army.mil

**Aviation Applied Technology
Directorate, (AATD), USAAMCOM**
Building 401
Fort Eustis, VA 23604-5577



Commander:
COL Waldo F. Carmona
ATTN: AMSAM-AR-T
C: 757-878-2208
DSN: 927-2208
wcarmona@eustis-aatdsl.army.mil

Deputy Director: Mr. Danny E. Good
ATTN: AMSAM-AR-TD
C: 757-878-3507; DSN: 927-3507
dgood@eustis-aatdsl.army.mil
Aviation R&D Coordinator: CW5
Richard Johnson
ATTN: AMSAM-AR-T-TR
C: 757-878-3171; DSN: 927-3171
rjohnson@eustis-aatdsl.army.mil

Fort Monroe

**Aviation Div., Individual Training Dir.,
DCS of Training, TRADOC**
Fort Monroe, VA 23651

TRADOC Aviation Officer/Chief: LTC
Michael G. Garrison
ATTN: ATTG-IA
C: 757-728-5685; DSN: 680-5685
garrison@monroe.army.mil

Air Traffic Control Branch: Mr.
Anthony Johnson
ATTN: ATTG-IA
C: 757-728-5638; DSN: 680-5638
johnson2@monroe.army.mil

Standardization Branch: CW5 David
Heaton
ATTN: ATTG-IA
C: 757-728-5640; DSN: 680-5640
heatond@monroe.army.mil

Operations Branch: Ms. Judy Dyer
ATTN: ATTG-IA
C: 757-728-5683; DSN: 680-5683
dyerj@monroe.army.mil

ARNG Aviation Coordinator: MAJ
David Bowles
ATTN: ATTG-IA
C: 757-728-5680; DSN: 680-5680
bowlesd@monroe.army.mil

Enlisted Training Branch: SGM
Joseph Shabbott
ATTN: ATTG-IA
C: 757-728-5618; DSN: 680-5618
shabbotj@monroe.army.mil

**Joint Warfighting Div., Requirements
Integration Dir., TRADOC**
Fort Monroe, VA 23651-5000
Chief: LTC Lewis E. Buchanan
ATTN: ATCD-MJ EJ
C: 757-727-4244; DSN: 680-4244

Richmond

**Office, State Adjutant General,
Virginia National Guard**
600 E. Broad Street
Richmond, VA 23219-1832



TAG:
MG Carroll Thackston
ATTN: VAAG
C: 804-775-9102
DSN: 953-2102
tagva@va-ngnet.army.mil

Sandston

**Office, State Army Aviation Officer,
Virginia Army National Guard
Army Aviation Support Facility**
Richmond International Airport
700 Portugee Road
Sandston, VA 23150-5050

SAAO: COL William A. Simpson
ATTN: VAAV
C: 804-236-7301; DSN: 864-7301
saova@va-arng.ngb.army.mil

**Virginia Army National Guard Army
Aviation Support Facility**
Richmond International Airport
700 Portugee Road
Sandston, VA 23150-5050
AASFC: COL William A. Simpson
ATTN: VAAV
C: 804-236-7301; DSN: 864-7301

**WASHINGTON
Dupont**

Aviation Support Facility Lewis
P. O. Box 5060
Dupont, WA 98327-5060
Facility Supervisor: Mr. Charles K.
Smith
ATTN: AFRC-AVIL-KG
C: 253-967-3083; DSN: 357-3083

Fort Lewis

**I Corps and Fort Lewis Aviation
Office**
Fort Lewis, WA 98433-5700
I Corps G3 Aviation Officer: CPT Troy
Kindred
ATTN: AFZH-GTO-D
C: 253-967-0035; DSN: 357-0035

Spokane

**Washington Army National Guard
Aviation Support Facility #2**
P. O. Box 19069
Spokane International Airport
Spokane, WA 99219-9069
AASFC: Vacant
ATTN: AASF-CDR
C: 509-458-5514; DSN: 820-7514

Tacoma

1-168th Theater Army Aviation
Camp Murray
Tacoma, WA 98430-5094
Commander: LTC Bret D. Daugherty
C: 253-967-5910; DSN: 357-5910
Senior NCO: CSM Robert J. Barr
C: 253-967-5910; DSN: 357-5910

66th Aviation Brigade (Corps)
Camp Murray
Tacoma, WA 98430-5000



Commander:
BG Errol H. Van Eaton, ARNG
ATTN: WHYUAA
C: 253-967-3027
DSN: 357-3027
bde66avn@wa-ngnet.army.mil



Senior NCO:
CSM William T. White
ATTN: WYHUAA
C: 253-967-3027
DSN: 357-3027
bde66avn@wa-ngnet.army.mil

**Office, State Adjutant General,
Washington ARNG**
Camp Murray
Tacoma, WA 98430-5000



TAG:
MG Gregory P. Barlow
C: 253-512-8000
DSN: 323-8000

**Office, State Army Aviation Officer,
Washington ARNG**
Aviation Support Facility 1
Camp Murray
Tacoma, WA 98430-5152
SAAO: COL Peter Holmberg
ATTN: AVN
C: 253-964-7220; DSN: 323-7220

**Washington Army National Guard
Aviation Support Facility 1**
Camp Murray
Tacoma, WA 98430-5152
AASFC: LTC Harry P. Haroldson
ATTN: AVN
C: 253-253-964-7200; DSN: 323-7200

**WEST VIRGINIA
Bridgeport**

**Fixed Wing ARNG Aviation Training
Site (FWAATS)**
1000 Fixed Wing Drive
Bridgeport, WV 26330-9753



Commander:
LTC Scott Wagner
C: 304-842-8870
DSN: 366-6593
fwaatswv@wv-arng.ngb.army.mil

Charleston

**Office, State Adjutant General, West
Virginia ARNG**
1703 Coonskin Drive
Charleston, WV 25311-1085
TAG: MG Allen E. Tackett
C: 304-369-6780; DSN: 355-6316

Wheeling

**West Virginia ARNG Army Aviation
Support Facility #2**
R.R. #5, P. O. Box 14
Wheeling, WV 26003
AASFC: LTC Glenn Kelly
ATTN: WVAR-AASF2
C: 304-277-2733; DSN: 366-6586
wvaasf2@ovnet.com

Williamstown

**Office, State Army Aviation Officer,
West Virginia ARNG
Army Aviation Support Facility #1**
Route 1, P. O. Box 224B
Williamstown, WV 26187

SAAO: COL Roger D. Thomas
C: 304-464-4383; DSN: 366-6264
saonrv@wv-arng.ngb.army.mil

**West Virginia Army National Guard
Army Aviation Support Facility**
Route 1, P. O. Box 224B
Williamstown, WV 26187

WISCONSIN Fort McCoy

Aviation Support Facility McCoy
Fort McCoy, WI 54656-5143
Facility Supervisor: Mr. Rodney W. Lauck
C: 608-388-5641; DSN: 280-5641

Madison

**Office, State Adjutant General,
Wisconsin Army National Guard**
P. O. Box 8111
Madison, WI 53708-8111

TAG:
MG James G. Blaney
ATTN: WING-Z
C: 608-242-3001
DSN: 724-3001

**Office, State Army Aviation Officer,
Wisconsin Army National Guard
Office of the Adjutant General
Dept. of Military Affairs**
2400 Wright Street
Madison, WI 53704-2572



SAAO:
LTC Craig L. Schuetz
ATTN: WIAF-AVN
C: 608-242-3140
DSN: 724-3140
saowi@wi-arng.ngb.army.mil

**Wisconsin Army National Guard
Aviation Support Facility #2**
Truax Field
1950 Pearson Street
Madison, WI 53704-2517
AASFC: LTC Jeffrey D. Paulson
ATTN: AASF-A
C: 608-242-3901; DSN: 724-3901
aasf2wi@wi-arng.ngb.army.mil

1st Battalion, 147th Aviation
1954 Pearson Street
Madison, WI 53704-2517
Commander: MAJ James F. Roth
C: 608-242-3875; DSN: 724-3875
Executive Officer: MAJ Kevin J. Greenwood
ATTN: WTQZTO-XO
C: 608-242-3875; DSN: 724-3876
greenk@wi-arng.ngb.army.mil
SIP: CW4 Jack M. Fankhauser
C: 608-242-3908; DSN: 724-3908
ASO: CW4 Robert C. Kenney
C: 608-242-3882; DSN: 724-3882
MTP: Mr. Robert G. Seales
C: 608-242-3920; DSN: 724-3920
Senior NCO: 1SG Jeffery S. Janke
C: 608-242-3895; DSN: 724-3895

West Bend

832d Medical Company
125 Chopper Drive
West Bend, WI 53095-8985
Commander: MAJ Russell J. Sweet
C: 414-334-9155; DSN: 724-3147
832medco@wi-arng.ngb.army.mil

**Wisconsin Army National Guard
Aviation Support Facility #1**
125 Chopper Drive
West Bend, WI 53095-8985
AASFC: MAJ Russell Sweet
ATTN: AASF-A
C: 608-242-3147; DSN: 724-3147
aasf1wi@wi-arng.ngb.army.mil

WYOMING Cheyenne

1022d Medical Company
5500 Bishop Boulevard
Cheyenne, WY 82009
Commander: MAJ Scott H. Schofield
C: 307-772-5247; DSN: 943-5247
1022@wy-iso.army.mil

**Office, State Adjutant General,
Wyoming Army National Guard**
500 Bishop Boulevard
Cheyenne, WY 82009-3320
TAG: MG Edmond Boenisch
C: 307-772-5234; DSN: 943-5234
eboenisch@wycys.ang.af.mil

**Office, State Army Aviation Officer,
Wyoming Army National Guard
Army Aviation Support Facility**
4600 Powderhouse Road
Cheyenne, WY 82009-4807
SAAO: COL Frank M. Henrich
C: 307-772-5999; DSN: 943-5999

**Wyoming Army National Guard
Aviation Support Facility**
4600 Powderhouse Road
Cheyenne, WY 82009-4807
AASFC: COL Frank M. Henrich
C: 307-772-5999; DSN: 943-5999

GERMANY APO AE

**Aviation Office, ODCSOPS,
USAREUR**
Unit 29351
APO AE 09014
USAREUR Aviation Officer: Mr. James A. Phillips
ATTN: AEAGC-AV
C: (49) 6221-57-6095; DSN: 370-6095
phillipj@hq.hqusaureur.army.mil
Action Officer: MAJ Lee Hackle
ATTN: AEAGC-AV
C: (49) 6221-57-2565; DSN: 372-2565
hackled@hq.hqusaureur.army.mil
Senior NCO: SFC Anthony Polelli
ATTN: AEAGC-AV
C: (49) 6221-57-2566; DSN: 372-2566
polellia@hq.hqusaureur.army.mil
**Army Flight Operations Detachment
(AFOD), ODCSOPS, USAREUR**
Unit 29351
APO AE 09014

Commander: CW5 Joe Irvine
ATTN: AEAGC-AV-AFOD-CO
C: (49) 6221-17-6201; DSN: 373-6201
irvinej@hq.hqusaureur.army.mil
Detachment Sergeant: SFC Rosalyn Muse
ATTN: AEAGC-AV-AFOD-1SG
C: (49) 6221-17-6201; DSN: 373-6201
muser@hq.hqusaureur.army.mil
Operations Officer: CW4 Steve Serchuk
ATTN: AEAGC-AV-AFOD-1SG
C: (49) 6221-17-6201; DSN: 373-6201
serchuks@hq.hqusaureur.army.mil
Operations Officer: CW5 Thomas Brandli
ATTN: AEAGC-AV
C: (49) 6221-17-6201; DSN: 370-6201
avn@heidelberg-dcsops1.army.mil

2-502d Aviation Regiment
Unit #29719
APO AE 09028
Commander: LTC Thomas J. Boyle
ATTN: AERAS-AV-CO
C: (49) 6221-779-5198; DSN: 382-5405
brooks%70tranbn@taacom.
kaiserslautern.army.mil

Executive Officer: MAJ Roland Haun
ATTN: AERAS-V-XO
C: (49) 621-779-5200; DSN: 382-5200
70xo%70trnbn@taacom.
kaiserlautern.army.mil

SIP: CW3 Neil W. Donovan
ATTN: AERAS-V-O
C: (49) 621-779-5159; DSN: 382-5159

ASO: CW2 Joseph Osborn
ATTN: AERAS-V-S
C: 011-49-621-779-5159; DSN: 382-5159

MTEF: CW3 Joe Q. Benton
ATTN: AERAS-V-OP-QC
C: (49) 621-779-5100; DSN: 382-5241
PC Officer: CW4(P) Zan D. Aslett
ATTN: AERAS-V-A
C: (49) 621-779-5100; DSN: 382-5100

Senior NCO: Master Sergeant Dumrong Tonkphontong
C: (49) 621-779-5280; DSN: 382-5280

**USAAVNC Liaison to German Army
Aviation**
TRADOC LO HFS
PSC 117, Box 115
APO AE 09080-0115
Liaison Officer: MAJ Keith R. Meeker
ATTN: ATDO-YF-GAV
C: 011-49-5722-26278
0572226278-001@t-online.de

Aviation Office, V U.S. Corps
12th Avn. Bde., Unit 29632
APO AE 09096
V Corps Aviation Officer: COL Jeff J. Schloesser
ATTN: AETV-AV
C: (49) 611-705-5857; DSN: 337-5857
12avncdr@12avn.wiesbaden.army.mil
Assistant V Corps Aviation Officer:
LTC Greg Adams
ATTN: V Corps
C: (49) 611-705-5312; DSN: 370-5312
g3avnchief@hq.c5.army.mil

**1st Military Intelligence Battalion,
(Aerial Exploitation)**
CMR 430
APO AE 09096



Commander:
LTC Vernon L. Campbell
ATTN: AETV-MIA
C: (49) 611-705-5416
DSN: 337-5416

Executive Officer: MAJ Steven P. Carney
ATTN: AETV-MIA-XO
C: (49) 611-705-5683; DSN: 337-5683
S3: MAJ Laura L. Singer
ATTN: AETV-MIA-SC
C: (49) 611-705-5218; DSN: 337-5318
HHS Commander: CPT Scott Nelson*
ATTN: AETV-MIA-HS
C: (49) 611-705-5153; DSN: 337-5153
B Co Commander: CPT James R. Harrell
ATTN: AETV-MIA-CB
C: (49) 611-705-5645; DSN: 337-5645



Senior NCO:
CSM Faron D. Barton
ATTN: AETV-MIA-CSM
C: (49) 611-705-5416
DSN: 337-5416

159th Medical Company (AA)
CMR 467
APO AE 09096
Commander: MAJ William J. Layden
ATTN: AETV-MB-WB-AAW-CO
C: 011-49-611-7055565; DSN: 337-5565
159thmed@med30.heidelberg.
amedd.army.mil

**3d Battalion, 58th Aviation Regiment
(ATS)**
CMR 430
APO AE 09096
Commander: LTC Jeffrey G. Gregson
ATTN: AETV-ABS
C: (49) 611-705-6421; DSN: 337-6421
gregsonj@12av.wiesbaden.army.mil
Executive Officer: MAJ William K. Miller
ATTN: AETV-ABS-XO
C: (49) 611-705-5560; DSN: 337-5560
3-58avxo@12av.wiesbaden.army.mil
S-3: MAJ David A. Chapman
ATTN: AETV-ABS-S3
C: (49) 611-705-5557; DSN: 337-5557
3-58avs3@12av.wiesbaden.army.mil
Senior NCO: CSM Leonie De La Cruz
ATTN: AETV-ABS-SM
C: (49) 611-705-5558; DS: 337-5558

12th Aviation Brigade
Unit 29632
APO AE 09096-5000



Commander:
COL Jeffrey J. Schloesser
ATTN: AETV-AB
C: (49) 611-705-5857
DSN: 337-5857
12avncdr@12avn.
wiesbaden.army.mil

Executive Officer: LTC Rick Russell
ATTN: AETV-ABH-XO
C: (49) 611-705-6885; DSN: 337-6885
12avnxo@12avn.wiesbaden.army.mil

SIP: CW4 Noel Seale
ATTN: AETV-ABC-IP
C: (49) 611-705-5469; DSN: 337-5469
12avnsip@12avn.wiesbaden.army.mil
ASO: CW3 Mark Atkins
ATTN: AETV-ABA-SO
C: (49) 611-705-5469; DSN: 337-5469



Senior NCO:
CSM Hiram Claytor
ATTN: AETV-ABH-SM
C: (49) 611-705-5897
DSN: 337-5897
12avncsm@12avn.wiesbaden.army.mil

U.S. Army Flight Operations Detachment
USAREUR & 7th USA
Unit 29231
APO AE 09102



Commander:
CW5 Joe Irvine
ATTN: AEAGC-AV-AFOD-CO
C: 011-49-6221-17-6201
DSN: 373-6201
irvinej@hq.hqusareur.army.mil

Flight Operations Officer:
CW4 Steve Serchuk
ATTN: AEAGC-AV-AFOD-FLTOPS
C: 011-49-6221-17-6201; DSN: 370-7827
serchuks@hq.hqusareur.army.mil



Senior NCO:
SFC Rosalyn E. Muse
ATTN: AEAGC-AV-AFOD-1SG
C: 011-49-6221-17-6201
DSN: 370-6201
muser@hq.hqusareur.army.mil

207th Aviation Company, ODCSOPS, USAREUR
Unit 29231
APO AE 09102



Commander:
MAJ Michel E. Hadad
ATTN: AEAGC-0-207-CO
C: (49) 6221-17-8990
DSN: 373-8990
hadadm@hq.hqusareur.army.mil

Executive Officer: CPT Kimberly Enderle
ATTN: AEAGC-0-207-XO
C: (49) 6221-17-8990; DSN: 373-8990
enderlek@hq.hqusareur.army.mil
SIP: CW4 Michael Pascalor
ATTN: AEAGC-0-207-SIP
C: (49) 6221-17-6822; DSN: 373-6822
pascalorm@hq.hqusareur.army.mil



Senior NCO:
1SG Gordon F. Murray
C: (49) 6221-17-8990
DSN: 373-8990
murrayg@hqusareur.army.mil

7th Army Training Command, Aviation Detachment
Grafenwoehr Army Airfield
APO AE 09114-5413
Commander: CPT Mark Radtke
ATTN: AETT-SGS-AV
C: (49) 964-183-8331; DSN: 475-8331
Radtkem@hq.7atc.army.mil
Operations Officer: CW2 Allen Nix
ATTN: AETT-SGS-AV
C: (49) 964-183-7147; DSN: 475-7147
nixax@fltdet.7atc.army.mil
FW/SIP: CW4 Rick Williams
ATTN: AETT-SGS-AV
C: (49) 964-183-8331; DSN: 475-8331
williamr@fltdet.7atc.army.mil
RW/SIP: CW4 Tim Porter
ATTN: AETT-SGS-AV
C: (49) 964-183-8331; DSN: 475-8331
portert@fltdet.7atc.army.mil
ASO: CW3 Rob Carter
ATTN: AETT-SGS-AV
C: (49) 964-183-7833; DSN: 475-7833
carterj@email.grafenwoehr.army.mil
Senior NCO: SFC Steven Klatt
ATTN: AETT-SGS-AV
C: (49) 964-183-6117; DSN: 475-6117
klatts@fltdet.7atc.army.mil

11th Aviation Regiment
CMR 416
V Corps
APO AE 09140
Commander: COL Oliver H. Hunter IV
ATTN: AETV-AVA
C: (49) 9841-83-815; DSN: 467-4815
huntero@email.ansbach.army.mil
Executive Officer: MAJ Paul J. Wood
ATTN: AETV-AVA-XO
C: (49) 9841-83-815; DSN: 467-4815
11avnxo@email.ansbach.army.mil
SIP: CW5 William E. Tucker, Jr.
ATTN: AETV-AVA-C
C: (49) 9841-83-535; DSN: 467-4535
ATTN: AETV-AVA-C
AETV-AVA-STD@email.ansbach.army.mil
ASO: CW5 Michael Nadeau
ATTN: AETV-AVA-G
C: (49) 9841-83-780; DSN: 467-3780
11avnsaf@email.ansbach.army.mil
Senior NCO: CSM Jasper Tenney
ATTN: AETV-AVA-CSM
C: (49) 9841-83-815; DSN: 467-4815
11avncsm@email.ansbach.army.mil

2d Squadron (Attack), 6th Cavalry "Fighting Sixth"
11th Aviation Regiment
APO AE 09140



Commander:
LTC George H. Rhyndance
ATTN: AETV-AVA-V-CDR
C: (49) 9841-83-802
DSN: 467-4802
26cavcdr@email.ansbach.army.mil

Executive Officer: MAJ Chris Jose
ATTN: AETV-AVA-V-XO
C: (49) 9841-83-843; DSN: 467-4843
26cavxo@email.ansbach.army.mil
SIP: CW4 Brian Dunn
ATTN: AETV-AVA-V-SIP
C: (49) 9841-83-783; DSN: 467-4783
ASO: CW4 Robert Snider
ATTN: AETV-AVA-V-ASO
C: (49) 9841-83-457; DSN: 467-4457

MTFE: CW3 Jeff Fitzgerald
ATTN: AETV-AVA-V-DT
C: (49) 9841-83-532; DSN: 467-4532
Senior NCO: CSM Michael F. Noehl, Jr.
ATTN: AETV-AVA-V-CSM
C: (49) 9841-83-843; DSN: 467-4843
26cavcsm@email.ansbach.army.mil

6th Squadron (Attack), 6th Cavalry "Sixshooters"
11th Aviation Regiment
APO AE 09140



Commander:
LTC George M. Bilafer
ATTN: AETV-AVA-CS-CDR
C: (49) 9841-83-961
DSN: 467-4961
66cavcdr@email.ansbach.army.mil

Executive Officer: MAJ Robert B. Allen
ATTN: AETV-AVA-CS-XO
C: (49) 9841-83-971; DSN: 467-4971
66cavxo@email.ansbach.army.mil
S-3: MAJ Robert L. Douthit
ATTN: AETV-AVA-CS-S-3
C: (49) 9841-83-970; DSN: 467-4970
66cavs3@email.ansbach.army.mil
S-1: 1LT Christina M. Pierce-Neumann
ATTN: AETV-AVA-CS-1
C: (49) 9841-83-962; DSN: 467-4962
66cavs1@email.ansbach.army.mil
SIP: CW3 Carl Farrow
ATTN: AETV-AVA-CS-SIP
C: (49) 9841-83-405; DSN: 467-4405
66cavso@email.ansbach.army.mil
ASO: CW3 Paul Clark
ATTN: AETV-AVA-CS-ASO
C: (49) 9841-83-405; DSN: 467-4405
66cavso@email.ansbach.army.mil
MTFE: CW3 Eric Rings
ATTN: AETV-AVA-CS-MFTE
C: (49) 9841-83-915; DSN: 467-4915
66cavpc@email.ansbach.army.mil
Acting Senior NCO: Master Sergeant Robert D. Sparks
ATTN: AETV-AVA-CS-CSM
C: (49) 9841-83-967; DSN: 467-4967
66cavcsm@email.ansbach.army.mil

7th Battalion, 159th Aviation Regiment
CMR 416
APO AE 09140
Commander: LTC Richard A. Enderle
ATTN: AETV-SCS-F
C: (49) 9841-83-791; DSN: 467-4791
enderler@email.ansbach.army.mil
Executive Officer: MAJ Joseph Ciampini
ATTN: AETV-SCS-FX
C: (49) 9841-83-792; DSN: 467-4792
ciampinij@email.ansbach.army.mil

ASO: CW5 Colin S. Hudson
ATTN: AETS-SCS-FE
C: (49) 9841-83-471; DSN: 467-4471
hudsoncs@email.ansbach.army.mil
MTFE: CW5 Steve Noe
ATTN: AETV-SCS-FSM
C: (49) 9841-83-982; DSN: 467-4982
noes@email.ansbach.army.mil
Senior NCO: CSM Larry Jeffcoat
ATTN: AETV-SCS-FCSM
C: (49) 9841-83-793; DSN: 467-4793

4th Brigade, 1st Armored Division
CMR 477
APO AE 09165

Commander: COL Christopher L. Sargent
ATTN: AETV-THR
C: (49) 6183-51-693; DSN: 322-7693
4bdecd@4thbdehq.lad.army.mil
Executive Officer: MAJ Darryl Sharnblin
ATTN: AETV-THR-XO
C: (49) 6183-51-467; DSN: 322-7467
4bdexo@4thbdehq.lad.army.mil
SIP: CW5 John Peterson
ATTN: AETV-THR-SIP
C: (49) 6183-51-623; DSN: 322-7623
4bdestans@4thbdehq.lad.army.mil
ASO: CW5 Daniel Heath
ATTN: AETV-THR-ASO
C: (49) 6183-51-679; DSN: 322-7679
4bdesafety@4thbdehq.lad.army.mil
MTFE: CW5 David Landrum
ATTN: AETV-THR-MTFE
C: (49) 6183-51-772; DSN: 322-7772
4bdebamo@4thbdehq.lad.army.mil
Senior Tactical EW Officer: CW5 Steve Knowles
ATTN: AETV-THR-SC
C: (49) 6183-51-565; DSN: 322-7565
4bdetacops@4thbdehq.lad.army.mil



Senior NCO:
CSM Gabriel Villaseor
ATTN: AETV-THR-CSM
C: (49) 6183-51-499
DSN: 322-7499
4bdccsm@4thbdehq.lad.army.mil

2nd Battalion, 501st Aviation Regiment
4th Brigade
CMR 477
1st Armored Division
APO AE 09165

Commander: LTC Steve Westphal
ATTN: AETV-THR-C
C: (49) 6184-51-701; DSN: 322-7701
Executive Officer: MAJ Ken Barrett
ATTN: AETV-THR-C-XO
C: (49) 6184-51-780; DSN: 322-7780
SIP: CW3 Bob Caprara
ATTN: AETV-THR-C-SS
C: (49) 6184-51-631; DSN: 322-7631
ASO: CW4 Lonnie Scott
ATTN: AETV-THR-C-SS
C: (49) 6184-51-631; DSN: 322-7631
Senior NCO: CSM Gary L. Moore
ATTN: AETV-THR-C-CSM
C: (49) 6184-51-577; DSN: 322-7577

1-501st Attack Helicopter Battalion
4th Brigade
CMR 477
1st Armored Division
APO AE 09165-1539

Commander: LTC Daniel Garvey
ATTN: AETV-THR-B
C: (49) 6183-51-504; DSN: 322-7504
1501avcdr@1501hq.1ad.army.mil
Executive Officer: MAJ John Dowd
ATTN: AETV-THR-B-XO
C: (49) 6183-51-660; DSN: 322-7660
1501avxo@1501hq.1ad.army.mil
SIP: CW4 Mark Koenig
ATTN: AETV-TFJ-B-SIP
C: (49) 6183-51-705; DSN: 322-7705
1501avstnds@1501hq.1ad.army.mil

ASO: CW3 Art Blakemore
ATTN: AETV-THR-B-ASO
C: (49) 6183-51-790; DSN: 322-7790
1501avaso@1501hq.1ad.army.mil
Senior NCO: CSM George Evans
ATTN: AETV-THR-B-CSM
C: (49) 6183-51-756; DSN: 322-7756
1501avcsm@1501hq.1ad.army.mil

127th Aviation Support Battalion
Unit #20198
APO AE 09165-1624

Commander: LTC Timothy Cornett
ATTN: AETV-THR-SB
C: (49) 6183-51-528; DSN: 322-7528

Executive Officer: MAJ Riggins
ATTN: AETV-THR-SB-XO
C: (49) 6183-51-440; DSN: 322-7440

Senior NCO: CSM Mike Marler
ATTN: AETV-THR-SB-CSM
C: (49) 6183-51-440; DSN: 322-7440
127asbcm@asb127hq.1ad.army.mil

HQ & Supply Company Commander:
CPT Scott Rhoden
ATTN: AETV-THR-SB-HSC
C: (49) 6183-51-732; DSN: 322-7732
rhodens@email.hanau.army.mil

A Company (AVIM) Commander: CPT
Randy Masten
ATTN: AETV-THR-SB-A
C: (49) 6183-51-706; DSN: 322-7706
mastenr@email.hanau.army.mil

B Company (Ground Maintenance)
Commander: CPT Pam Holwerda
ATTN: AETV-THR-SB-B
C: (49) 6183-51-694; DSN: 322-7694
pholwerda@mzk-link.dla.mil

Combat Maneuver Training Center
CMR 414, Box 1823
ATTN: Falcons
APO AE 09173-1823
Aviation Detachment Senior Trainer:
LTC John Kelley
C: (49) 9472-83-2867; DSN: 466-2867
kelleyj@cmtc.7atc.army.mil

Aviation Detachment Executive
Officer: MAJ Jay Smith
C: (49) 9472-83-2891; DSN: 466-2891
smithj@cmtc.7atc.army.mil

Aviation Detachment Operations
Officer: MAJ Jimmy Meacham
C: (49) 9472-83-4438; DSN: 466-4438
meachamj@cmtc.7atc.army.mil

Aviation Detachment Tactical
Operations Officer: CW4 Ken Sargent
C: (49) 9472-83-2451; DSN: 466-2451
sargentk@cmtc.7atc.army.mil

Aviation Detachment Maintenance
Officer: CW2 Jerry Forrest
C: (49) 9472-83-2224; DSN: 466-2224
forrestj@cmtc.7atc.army.mil

Senior NCO: CSM William Clarke
C: (49) 9472-83-2352; DSN: 466-2352
clarkew@cmtc.army.mil

236th Medical Company
CMR 402
APO AE 09180-3630

5th Battalion, 158th Aviation
Regiment
CMR 408
APO AE 09182
Commander: LTC Raymond P. Palumbo
ATTN: AETV-ABR
C: (49) 9334-8-7342; DSN: 352-7342
cdr-158@email.wuerzburg.army.mil

Executive Officer: MAJ Jack Parkhurst
ATTN: AETV-ABR-XO
C: (49) 9334-8-7846; DSN: 352-7846
xo-158@email.wuerzburg.army.mil
SIP: CW4 Spike Condon
ATTN: AETV-ABR-IP
C: (49) 9334-8-7378; DSN: 352-7378
stan158@email.wuerzburg.army.mil
ASO: CW4 Greg Schneider
ATTN: AETV-ABR-SO
C: (49) 9334-8-7589; DSN: 352-7589
safe158@email.wuerzburg.army.mil
S-3: MAJ Mike Dixon
ATTN: AETV-ABR-C
C: (49) 9334-8-77-45; DSN: 352-7745
s3158@email.wuerzburg.army.mil
Senior NCO: CSM Willie F. Williams
ATTN: AETV-ABR-SM
C: (49) 9334-8-7342; DSN: 352-7342
csm158@email.wuerzburg.army.mil

1st Battalion, (Attack) 1st Aviation
Regiment
Aviation Brigade
1st Infantry Division
CMR 454
APO AE 09250



Commander:
LTC David J.
Abramowitz
ATTN: AETV-BGK-M
C: (49) 9802-832-783;
DSN: 467-2783
hq11avn@email.ans-
bach.army.mil

Executive Officer: MAJ Mike Williams
ATTN: AETV-BGK-MX
C: (49) 9802-832-355; DSN: 467-2355
xo11avn@email.ansbach.army.mil
SIP: CW3 Rusen Wells
C: (49) 9802-832-609; DSN: 467-2609
ASO: CW3 Mike Owens
C: (49) 9802-832-609; DSN: 467-2609
MTP: CW4 Gary S. Weigand
C: (49) 9802-832-890; DSN: 467-2890
ARMAMENT: CW4 J.D. Douglas
C: (49) 9802-832-474; DSN: 467-2474
S-3: MAJ Scott Fellows
C: (49) 9802-832-603; DSN: 467-2603
D Company Commander: CPT Pete
van Prooyen
C: (49) 9802-832-783; DSN: 467-2783



Senior NCO:
CSM Donald K. Henry
C: (49) 9802-832-783
DSN: 467-783

2nd Battalion, 1st Aviation Regiment
CMR 454
APO AE 09250



Commander:
LTC John C. Burns
ATTN: AETV-BGK-T
C: (49) 9802-832-627
DSN: 467-2627
cdr21avn@email.
ansbach.army.mil

Executive Officer: MAJ Travis
Flewelling
ATTN: AETV-BGK-TX
C: (49) 9802-832-627; DSN: 467-2627
xo21avn@email.ansbach.army.mil
SIP: CW4 Stephen F. Gilmore
ATTN: AETV-BGK-TG
C: (49) 9802-832-561; DSN: 467-2561
gilmore@email.ansbach.army.mil
S-3: MAJ John G. Kershaw
ATTN: AETV-BGK-T
C: (49) 9802-832-854; DSN: 467-2854
5321avn@email.ansbach.army.mil
ASO: CW4 Duane A. Gere
ATTN: AETV-BGK-TS
C: (49) 9802-832-561; DSN: 467-2561
gered@email.ansbach.army.mil
AVIM Commander: CPT Susan M.
Duke
ATTN: AETV-BGK-TL
C: (49) 9802-832-874; DSN: 467-2874
dco21avn@email.ansbach.army.mil



Senior NCO:
CSM James A.
McGlocklin, Jr.
ATTN: AETV-BGK-TZ
C: (49) 9802-832-626
DSN: 467-2626
csm21avn@email.
ansbach.army.mil

4th Brigade, 1st Infantry Division
CMR 454
APO AE 09250



Commander:
COL John R. Combs
ATTN: AETV-BGK-C
C: (49) 9802-832-623
DSN: 467-2623
hq4bde@email.
ansbach.army.mil

Executive Officer: LTC Mark W. Barefield
ATTN: AETV-BGK-X
C: (49) 9802-832-624; DSN: 467-2624
xo-4bde@email.ansbach.army.mil
Brigade S-3: MAJ John Karaus
ATTN: AETV-BGK-C
C: (49) 9802-832-880; DSN: 467-2880
s34bde@email.ansbach.army.mil
SIP: CW5 Leon McInelley
ATTN: AETV-BGK-S
C: (49) 9802-832-739; DSN: 467-2739
stan4bde@email.ansbach.army.mil
ASO: CW4 John M. Murray
ATTN: AETV-BGK-S
C: (49) 9802-832-807; DSN: 467-2807
MurrayJ@email.ansbach.army.mil
BAMO: CW5 Paul Pence
ATTN: AERV-BGK-Z
C: (49) 9802-832-623; DSN: 467-2623
aetv-bgk-z@email.ansbach.army.mil



Senior NCO:
CSM David B. Rabon
C: (49) 9802-832-623
DSN: 467-2623

45th Medical Company
APO AE 09250
Commander: MAJ John Cook
ATTN: AEMAA-NL
C: 09802832 793; DSN: 467-2793
aetv-mb-wa-aak02@email.ansbach.
army.mil

601st Aviation Support Battalion
DISCOM, 1st Infantry Division
CMR 454
APO AE 09250



Commander:
LTC Anthony Brogna
ATTN: AETV-BG-SC-
A
C: (49) 9802-832-8044
DSN: 467-2804
co-601sb@email.
ansbach.army.mil

Executive Officer: MAJ Zachary
Randall
ATTN: AETV-BG-SC-A-XO
C: (49) 9802-832-644; DSN: 467-2644
xo601@email.ansbach.army.mil
HQ & Supply Company: CPT Jess
Capel
ATTN: AETV-BG-SC-A-A
C: (49) 9802-832-695; DSN: 467-2695
cohsc@email.ansbach.army.mil
A Company (AVIM): MAJ Michael
Bradley
ATTN: AETV-BG-SC-A-C
C: (49) 9802-832-761; DSN: 467-2761
coaco@email.ansbach.army.mil
B Company (Ground Maintenance):
CPT Scott Simpkins
ATTN: AETV-BG-SC-A-B
C: (49) 9802-832-804; DSN: 467-2804
cobco@email.ansbach.army.mil



Senior NCO:
CSM Kurt Pinero
ATTN: AETV-BG-SC-
A-S
C: (49) 9802-832-644
DSN: 467-2644
csm601@email.
ansbach.army.mil

200th Theater Army Materiel
Management Center
Unit 23203
APO AE 09263
Chief, Aviation, Troop Missile
Division: Mr. Chuck Barnes
ATTN: AERLA-MMC-ATMD
C: (49) 631-413-8766; DSN: 484-8766
barnesc@hq.21taacom.army.mil
Chief, Aviation Branch: Mr. David
Spinks
ATTN: AERLA-MMC-ATMD
C: (49) 631-413-8900; DSN: 484-8900
spinksd@hq.21taacom.army.mil

SHAPE Flight Detachment
Unit 21409, CMR 450
APO AE 09705
Commander: MAJ Barry Stuckey
ATTN: ACFD
C: (32) 68-27-5277; DSN: 361-5277
stuckeyb@hqusaace.shape.army.mil
SIP: CW4 Robert L. Arms
ATTN: ACFD
C: (32) 68-27-5070; DSN: 361-5070
armsr@hqusaace.shape.army.mil
ASO: CW4 Dale A. Miller
ATTN: ACFD
C: (32) 68-27-5762; DSN: 361-5762
millerd@hqusaace.shape.army.mil
MFTE: CW3 Joe Henson
ATTN: ACFD
C: (32) 68-27-5860; DSN: 361-5860
hensonj@hqusaace.shape.army.mil

USAAVNC Liaison to French Army Aviation
TRADOC Aviation LO
 PSC 116
 Box A-209-A
 APO AE 09777
Liaison Officer: MAJ Robert Williams
 ATTN: ATFE-AV
 C: 33-04-94-85-52-47
 atfe-av@email.chievres.army.mil

**SINAI
APO AE**

Multinational Force and Observers
 USAE-MFO, Unit 31520
 APO AE 09832
Sr. Staff Officer, Aviation Supply & Maintenance: CPT Heidi A. Jentoft
 ATTN: USAE-CSP-FMO-AVSM
 C: 972-7-6281-801.x2831
 heidi@aquanet.co.il

**CANAL ZONE
APO AA**

1-228th Aviation Regiment
U.S. Army South
 Fort Kobbe, Panama
 APO AA 34001
Commander: LTC Robert M. Townsend
 ATTN: SOAR-PM
 C: 011-507-284-9236; DSN: 284-9228
 RSherman@USARSO-lan1.army.mil
Executive Officer: MAJ Vito Oter
 ATTN: SOAR-PMX
 DSN: 284-9236
 vtozer@usarso-lan1.army.mil
SIP: CW3 Billy Phillips
 ATTN: SOAR-PMO



Senior NCO:
 CSM Michael C. McSwain
 ATTN: SOAR-PMO
 DSN: 284-9236
 mmcsvain@usarso-lan1.army.mil

Aviation Division, U.S. Army South
 Fort Clayton, Panama
 APO AA 34004



Chief:
 Mr. Raymond F. O'Neill, Jr.
 ATTN: UNIT 7107,
 SOOP-AV
 C: 507-288-3322
 DSN: 313-288-3322
 roneill@usarso-lan1.army.mil

Company D, 228th Aviation Regiment
U.S. Army South
 PSC 42, (JTF-B)
 Soto Cano AB, Honduras
 APO AA 34042
Commander: MAJ Vincent Reap
 ATTN: SOAR-PMG
 C: 011-504-237-8833; DSN: 449-4306
Executive Officer: CPT James J. Walton
 ATTN: SOAR-PMG
 C: 011-504-237-8833; DSN: 449-4164
 waltonj@jtfb-emh1.army.mil

MEDEVAC Detachment Commander:
 CPT Michael Pouncey
 ATTN: SOAR-PMG
 C: 011-504-378-833-4232; DSN: 449-4232
 pounceym@jtfb-emh1.army.mil
S-3: CPT Sharon E. Decrane
 ATTN: SOAR-PMG
 C: 011-504-378-833-4241; DSN: 449-4241
SIP: CW4 John R. Kokoski
 ATTN: SOAR-PMG
 C: 011-504-378-833-4531; DSN: 449-4531
ASO: CW2 Charles D. Petrie
 ATTN: SOAR-PMG
 C: 011-504-378-833-4562; DSN: 449-4562
MTFE: CW3 James E. Wilson
 ATTN: SOAR-PMG
 C: 011-504-378-833-4252; DSN: 449-4252
Senior NCO: 1SG Ricky L. Coston
 ATTN: SOAR-PMG
 C: 011-504-378-833-4477; DSN: 449-4477

**KOREA
APO AP**

Aviation Office, Eighth U.S. Army
 APO AP 96204
 Aviation Officer: COL William J. Hatch
 ATTN: EAGC-EA
 DSN: 723-6507

1st Battalion, 52nd Aviation
17th Aviation Brigade
 Unit #15266
 APO AP 96205-0039
Commander: LTC Stephen R. Dwyer
 ATTN: EAAV-1BN-CO
 DSN: 741-6038
Executive Officer: MAJ Paul J. Ambrose
 ATTN: EAAV-1BN-XO
 DSN: 741-6055
S-3: MAJ Martin T. Carpenter
 ATTN: EAAV-1BN-OT
 DSN: 741-6621
ASO: CW4(P) Donald G. Andera
 ATTN: EAAV-1BN-STD
 DSN: 741-6037
Safety Officer: CW3 Jim Sawyer
 ATTN: EAAV-1BN-ASO
 DSN: 741-6043
Senior NCO: CSM Maurice L. Johnson
 ATTN: EAAV-1BN-CSM
 DSN: 741-6062

17th Aviation Brigade
 Unit #15270
 APO AP 96205-0043
Commander: COL James R. Myles
 ATTN: EAAV-CO
 C: 011-822-7913-5154; DSN: 723-5154
 mylesj@usfk.korea.army.mil
Brigade Executive Officer: LTC Richard G. Cercone
 ATTN: EAAV-XO
 C: 011-822-7913-5132; DSN: 723-5132
 cercone@usfk.korea.army.mil
Brigade S-3: LTC Gregory Back
 ATTN: EAAV-OT
 C: 011-822-7913-8359; DSN: 723-8359
 backg@usfk.korea.army.mil
Brigade Standardization Officer:
 CW5 Tom Flynn
 ATTN: EAAV-STD
 C: 011-822-7913-6734; DSN: 723-6734
 flynn@usfk.korea.army.mil

Brigade Safety Officer: CW5 R. Scott Johnson
 ATTN: EAAV-ASO
 C: 011-822-7913-5140; DSN: 723-5140
 johnsonsr@usfk.korea.army.mil



Brigade CSM:
 CSM David D. Tomblison
 ATTN: EAAV-CSM
 C: 011-822-7913-4634
 DSN: 723-4634
 tomblisond@usfk.korea.army.mil

Company Commander, HHC: CPT Evan J. Brown
 ATTN: EAAV-HHC
 C: 011-822-7918-8502; DSN: 738-8502
 browne@usfk.korea.army.mil

164th Air Traffic Services Group
 17th Aviation Brigade
 Unit #15276
 APO AP 96205-0049
Commander: LTC John S. Emmerson
 ATTN: EAAV-164-CO
 C: 011-82-02-4914-4021; DSN: 724-4021
 emmersonj@usfk.korea.army.mil
Deputy Commander: MAJ James P. Cassella
 ATTN: EAAV-164-DCO
 C: 011-82-02-7914-4023; DSN: 724-4023
 cassellaj@usfk.korea.army.mil
S-3: MAJ Willie E. Gaddis
 ATTN: EAAV-164-OT
 C: 011-82-02-7914-4009; DSN: 724-4009
 gaddisw@usfk.korea.army.mil
Safety Officer: WO1 Billy Frazier, Jr.
 ATTN: EAAV-164-SO
 C: 011-82-02-7914-8144
 frazierb@usfk.korea.army.mil
Senior NCO: CSM Richard C. Lewis
 ATTN: EAAV-164-CSM
 C: 011-82-02-7914-4020; DSN: 724-4020
 lewisc@usfk.korea.army.mil

Camp Page Army Airfield
 Unit #15002
 APO AP 96208-0252
Commander: CW3 Thomas R. Byrne
 ATTN: EANC-AIP-AFO
 C: 0361-59-5085; DSN: 721-5085

Camp Red Cloud Sub-Post Camp Page
 Unit #15002
 APO AP 96208-0252
Commander: CPT Craig J. Alia
 ATTN: EANC-AIP-CDR
 C: 011-82-361-59-5025; DSN: 721-5025
 eanc-hip-cdr@emh5.korea.army.mil
Senior NCO: Master Sergeant Jess Lopez, Jr.
 ATTN: EANC-AIP-IS
 C: 011-82-361-59-5311; DSN: 721-5311

1st Battalion, 2nd Aviation Regiment
Aviation Brigade, 2ID
 Unit #15008
 APO AP 96208-0476



Commander:
 LTC Anthony G. Crutchfield
 ATTN: EAID-AH-CO
 C: 011 82 361259 5942
 DSN: 721-5942
 CrutchfieldA@usfk.korea.army.mil

Executive Officer: MAJ John A. Picciuto
 ATTN: EAID-AH-XO
 C: 011 82 3612595943; DSN: 721-5943
 PicciutoJ@usfk.korea.army.mil
S-3: MAJ Mark T. Jones
 ATTN: EAID-AH-SO
 C: 011 823612595926; DSN: 721-5926
 JonesM@usfk.korea.army.mil
Standardization Officer: CW4 Theodore W. Hazen
 ATTN: EAID-AH-STD
 C: 011 823612595976; DSN: 721-5976
 HazenT@usfk.korea.army.mil
Safety Officer: CW3 Anthony M. Kurtz
 ATTN: EAID-AH-ASO
 C: 011 823612595976; DSN: 721-5976
 KurtzA@usfk.korea.army.mil



Senior NCO:
 CSM Joseph R. Bachus
 ATTN: EAID-AH-CSM
 C: 011 823612595941
 DSN: 721-5941
 BachusJ@usfk.korea.army.mil

542d Medical Company
 Unit #15705
 APO AP 96208-0705

4th Squadron, 7th Cavalry Regiment
 Unit #15141
 APO AP 96251-0388
Commander: LTC Robert N. Sweeney
 ATTN: EAID-CA-CO
 DSN: 734-2818
 eaid-ca-co@emh2.korea.army.mil
Executive Officer: MAJ Jim Chapman
 ATTN: EAID-CA-XO
 DSN: 734-2819
 eaid-ca-xo@emh2.korea.army.mil
SIP: CW3 Joe Lane
 ATTN: EAID-CA-FS
 DSN: 734-5976
 eaid-ca-sip@emh2.korea.army.mil
ASO: CW4 Bruce Davis
 ATTN: EAID-CA-SO
 DSN: 734-5355
 eaid-ca-ss@emh2.korea.army.mil
MTFE: CW3 Ellis McRoberts
 ATTN: EAID-CA-TF
 DSN: 734-5976
Senior NCO: CSM Herbert R. Moffett
 ATTN: EAID-CA-SM
 DSN: 734-2820

2d Battalion (Assault), 2d Aviation Regiment
Aviation Brigade, 2ID
 Unit #15427
 APO AP 96257-0460



Commander:
 LTC Keith S. Norris
 ATTN: EAID-AV-CO
 C: 011-82-351-870-5855
 DSN: 732-5855
 norrisk@usfk.korea.army.mil

Executive Officer: MAJ Greg A. Lind
 ATTN: EAID-AV-XO
 C: 011-82-351-870-5325; DSN: 732-5325
 lindga@usfk.korea.army.mil

SIP: CW4 Gordon L. Morey, Jr.
ATTN: EAID-AV-STN
C: 011-82-951-870-5986; DSN: 732-5986
moreyg@usfk.korea.army.mil
ASO: CW3 Scott M. Dillon
ATTN: EAID-AV-ASO
C: 011-82-351-870-5727; DSN: 732-5727
dillons@usfk.korea.army.mil



Senior NCO:
CSM Daniel F. Creed
ATTN: EAID-AV-CSM
C: 011-82-351-870-5324
DSN: 732-5324
creedd@usfk.korea.army.mil

Aviation Brigade, 2d Infantry Division
Unit #15435
APO AP 96257-0481

Commander: COL William L. Driver
ATTN: EAID-AA-CO
C: 011-82-351-870-5928; DSN: 732-5928
DriverW@usfk.korea.army.mil

Executive Officer: MAJ Lorenzo Riddick
ATTN: EAID-AA-XO
C: 011-82-351-870-5948; DSN: 732-5948
RiddickL@usfk.korea.army.mil

SIP: CW5 James D. Morgan
ATTN: EAID-AA-STD
C: 011-82-351-870-5939; DSN: 732-5939
MorganJD@usfk.korea.army.mil

ASO: CW5 Larry W. Newsom
ATTN: EAID-AA-S
C: 011-82-351-870-5939; DSN: 732-5939
NewsomL@usfk.korea.army.mil

Senior NCO: CSM Alfred W. Sayama
ATTN: EAID-AA-CSM
C: 011-82-351-870-5947; DSN: 732-5947
SayamaA@usfk.korea.army.mil

3d Squadron, 6th Cavalry
6th Cavalry Brigade (Air Cbt)
APO AP 96271



Commander:
LTC Ronald M. Buffkin
ATTN: EABH-3-6-CDR
C: 011-82-333-690-8320
DSN: 753-8320
buffkinm@usfk.korea.army.mil

Executive Officer: MAJ Louis A. Vogler
ATTN: EABH-3-6-XO
C: 011-82-333-690-7488; DSN: 753-7488
vogleri@usfk.korea.army.mil

SIP: CW4 Daniel O. Coulter
ATTN: EABH-3-6-SIP
DSN: 315-753-8557
eabh-3-6-sip@emh7.korea.army.mil

ASO: CW4 Hal Meeks
ATTN: EABH-3-6-SAFETY
DSN: 315-753-8523
eabh-3-6-safety@emh7.korea.army.mil

2nd Battalion, 52nd Aviation Regiment
17th Aviation Brigade
Unit 15188
APO AP 96271-0124

Commander: LTC Michael G. Mudd
ATTN: EAAV-2BN-CO
C: 011-82-333-690-6809; DSN: 753-6809
MuddM@usfk.korea.army.mil

Executive Officer: MAJ Jeffery M. Hayman
ATTN: EAAV-2BN-XO
C: 011-82-333-690-6813; DSN: 753-6813
HaymanJ@usfk.korea.army.mil

S-3: MAJ Laurence J. Sefren
ATTN: EAAV-2BN-OT
C: 011-82-333-690-6807; DSN: 753-6807
SefrenL@usfk.korea.army.mil

Standardization Officer: CW3 James A. Richie
ATTN: EAAV-2BN-SIP
C: 011-82-333-690-6844; DSN: 753-6844

Safety Officer: CW4 Concetta A. Hassan
ATTN: EAAV-2BN-ASO
C: 011-82-333-690-6844; DSN: 753-6844
HassanC@usfk.korea.army.mil

Tactical Operations Officer: CW4 John P. Mandulak
ATTN: EAAV-2BN-OT
C: 011-82-333-690-6802; DSN: 753-6802

Senior NCO: CSM Buford Thomas
ATTN: EAAV-2BN-CSM
C: 011-82-333-690-6810
ThomasBU@usfk.korea.army.mil

6th Cavalry Brigade
Unit 15711
APO AP 96271-0711

Brigade Commander: COL Edward J. Sinclair

ATTN: EABH-CDR
DSN: 753-6991
sinclair@usfk.korea.army.mil

Deputy Brigade Commander: LTC Jose R. Arroyo-Nieves
ATTN: EABH-DBC

Executive Officer: LTC Donald G. Reininger
DSN: 753-3938
reiningerd@usfk.korea.army.mil

SIP (AH-64): CW5 Ronald R. Porter
ATTN: EABH-STAN
DSN: 315-753-7962
porterr@usfk.korea.army.mil

ASO: CW4 James F. Hawkins
ATTN: EABH-SO
DSN: 753-7915
hawkinsj@usfk.korea.army.mil

Senior NCO: CSM Howard A. Loomis
ATTN: EABH-CSM
DSN: 753-3971
loomish@usfk.korea.army.mil

1st Squadron, 6th Cavalry
6th Cavalry Brigade (ARI Cbt)
Unit #15567
Camp Eagle, ROK
APO AP 96297



Commander:
LTC Joseph Contarino, III
ATTN: EABH-1-6-CO
C: 011-82-371-738-2006
DSN: 721-2006
contarinoj@usfk.korea.army.mil

Executive Officer: MAJ Jeffrey G. Hill
ATTN: EABH-1-6-XO
C: 011-82-371-738-2005; DSN: 721-2005
hillj@usfk.korea.army.mil

S-3: MAJ Karl I. Kearney
ATTN: EABH-1-6-S3
C: 011-82-371-738-2003; DSN: 721-2003
kearneyk@usfk.korea.army.mil

SIP: CW4 Tory R. Myers
ATTN: EABH-1-6-SIP
C: 011-82-371-738-2308; DSN: 721-2308
myers@usfk.korea.army.mil

ASO: CW4 David Lumley
ATTN: EABH-1-6-ASO
C: 011-82-371-738-2308; DSN: 721-2308
lumleyd@usfk.korea.army.mil

ROKA Staff NCOIC: SGM Youngkil Lee
ATTN: EABH-1-6-RSO
C: 011-82-371-738-2211; DSN: 721-2211



Senior NCO:
CSM James L. Digby
ATTN: EABH-1-6-CSM
C: 011-82-371-738-2201
DSN: 721-2201
digbyj@usfk.korea.army.mil

JAPAN
APO AP

5th Battalion, 501st Aviation
Regiment
17th Aviation Brigade
Unit #15567
APO AP 96297-0626

78th Aviation Battalion (Provisional)
APO AP 96343-0084



Commander:
LTC Michael O. Grant
ATTN: APAJ-GH-AV
C: 011-81-3117-63-9040
DSN: 263-9040
grantm@zama-emh5.army.mil

Executive Officer: MAJ Kevin R. Bishop
ATTN: APAJ-GH-AV
C: 011-81-3117-63-9041; DSN: 263-9041
bishopk@zama-emh5.army.mil

Battalion S-3: CPT Kenneth S. Allen
ATTN: APAJ-GH-AV
C: 011-81-3117-63-4243; DSN: 263-4243
allenk@zama-emh5.army.mil

Bn Standardization Officer: CW4 Wayne A. Denmark
ATTN: APAJ-GH-AV
C: 011-81-3117-63-3706; DSN: 263-3706
denmarkw@zama-emh5.army.mil

C-12J SIP: CW3 James R. Leech
ATTN: APAJ-GH-AV
C: 011-81-3117-64-4591; DSN: 264-4591
jleech@zam0-attnet.or.jp

UH-60A SIP: CW4 Dennis D. Dial
ATTN: APAJ-GH-AV
C: 011-81-3117-63-9033; DSN: 263-9033
diald@zama-emh5.army.mil

UC-35 SIP: CW3 Bruce W. Blackstone
ATTN: APAJ-GH-AV
C: 011-81-3117-64-4591; DSN: 264-4591

Fixed Wing Safety Officer: CW4 Thomas H. Fortune
ATTN: APAJ-GH-AV
C: 011-81-3117-64-4593; DSN: 264-4593

ASO: CW3 Matthew M. Pellegrino
ATTN: APAJ-GH-AV
C: 011-81-3117-63-3706; DSN: 263-9042
pellegrm@zama-emh5.army.mil

UH-1 MTFE: CW2 John S. Burt
ATTN: APAJ-GH-AV
C: 011-81-3117-63-3387; DSN: 263-3387
burtj@zama-emh5.army.mil

UH-60 MTFE: CW3 Daniel C. Woznick
ATTN: APAJ-GH-AV
C: 011-81-3117-63-3502; DSN: 263-3502

Senior NCO: Master Sergeant Douglas H. Kelley
ATTN: APAJ-GH-AV
C: 011-81-3117-63-5841; DSN: 263-5841
kelleyd@zama-emh5.army.mil

BREEZE-EASTERN RESCUE HOIST SYSTEM



HS-29900 RESCUE HOIST SYSTEM

- + 350 ft./min. speed at 600 lbs.
- + Integrated motor controller
- + Reliable brushless motor
- + Multiple control stations
- + NVG compatible displays
- + Unlimited duty cycle
- + 295 ft. cable length



SELECTED FOR THE UH-60Q MEDEVAC HELICOPTER PROGRAM

700 Liberty Avenue, Union, NJ 07083, USA
Telephone (908) 686-4000 FAX (908) 686-9292 Web Site: www.breeze-eastern.com

SEIZED CARS from \$175 - Porsches, Cadillacs, Chevys, BMW's, Corvettes. Also Jeeps, 4WD's. Your Area. Toll Free 1-800-218-9000 Ext. A-14106 for current listings.



☞ **Oct 12.** AAAA National Executive Board Meeting, Washington, D.C.

☞ **Oct 12.** AAAA Scholarship Foundation, Inc., Executive Committee Meeting, Washington, D.C.

☞ **Oct 24.** Army Aviation Center Chapter 7th Annual Chili 5K Race and Cook-Off, Center Parade Field, Fort Rucker. Contact Rich Carroll, (334) 255-3395.

☞ **Oct 27-29.** AHS/AAAA Eighth Helicopter Military Operations Technology (Helmet VIII) Specialist's Meeting, Williamsburg, VA.

☞ **Nov 13-14.** The Daleville & AAAA Annual Turkey Shoot and Shotgun Spectacular, Fort Rucker Skeet and Trap Range. Contact MAJ Rob Szempruch, (334) 255-8444.

☞ **Nov 17.** Army Aviation Center Chapter General Membership Meeting and Member Appreciation Night, Fort Rucker, O'Club. Contact 1LT Derrick Jee (334) 255-2579.

☞ **Nov 17-19.** AEC Symposium, Ocean Place Resort, Long Branch, N.J.

☞ **Jan. 11-13, 1999.** AUSA/AAAA Aviation Symposium, Fairview Park Marriott, Falls Church, Va.

☞ **Jan 27-29.** 25th Annual Joseph P. Cribbins Product Support Symposium, Huntsville, AL.

☞ **May 9-12.** AAAA Annual Convention, Nashville, TN.

advertisers index

Acme Electric Aerospace Division	33
AIAA	14
Air Methods Corporation, Products Div.	45
AlliedSignal Engines	49
ARINC Research Corporation	63
Bell Helicopter Textron	COVER 2
BFGoodrich Aerospace Avionics Systems	55
Boeing Aircraft & Missiles Div.	COVER 1
Breeze-Eastern	80
Contract Fabrication & Design, Inc.	29
DAC International, Inc.	84
DynCorp	9
GE Aircraft Engines	43
General Atomics Aeronautical Systems Inc	57
GSA	63
Hallcomb International, Inc.	85
Inter-Coastal Electronics	65

ITT Avionics Division	11
Kaiser Electroprecision	39
H. Koch & Sons Co.	20
Litton Applied Technology	41
Lockheed Martin ALC	27
Lucas Aerospace	COVER 3
MBNA	3
Merrill Lynch	22
Parker Aerospace	31
Pentagon Federal Credit Union	59
Precision Lift Inc.	19
Raytheon Aerospace, Contract Field Teams	25
Reflectone, Inc.	15
Regents College	81
Robertson Aviation, Inc.	13
Rockwell Collins, Inc.	COVER 4
Rolin Industries, Inc.	18

Sabreliner Corporation	47
Sears Industrial Sales	8
SEI Industries	19
Sikorsky Aircraft	37
Simula Safety Systems, Inc.	61
Smiths Industries	5
Stanley Manufacturing	21
Stevens Aviation, Inc.	17
St. Louis University	87
TEAC America, Inc.	7
Transupport, Inc.	61
USAA	23
Veridian/RAIL	35
Vickers Inc., TEDECO Division	53
Wyle Laboratories	51

CLIP HERE AND SHARE

Be Competitive!

Earn a College Degree no matter where you serve

Regents College introduces 4 new Associate Degrees

Servicemembers and veterans who have had military schooling and occupations evaluated for college credit by the American Council on Education may apply those recommended credits to one of the following 4 new Associate Degree options:

- **Associate in Applied Science (AAS) in Administrative/ Management Studies**
- **AAS in Aviation Studies**
- **AAS in Technical Studies with specialties in:**
 - *Chemical Studies*
 - *Computer Studies*
 - *Electromechanical Technology Studies*
 - *Electronic/Instrumentation Technology Studies*
 - *Nuclear Technology Studies*
- **Associate in Occupational Studies (AOS) in Aviation**

Regents College is flexible and portable with no residency requirement. And NOW Regents offers lower cost AAS/AOS Degree options. These new "hip-pocket" AAS/AOS Degree options apply to more than 80% of military occupations.

Use accredited local and distance college courses, military educational experiences and college-level proficiency exams, like Regents College Examinations, to complete our degree requirements.

Ask about the Regents College Credit Bank Service that consolidates all your accredited college-level learning into a single transcript.

Contact your education counselor or Regents College for an AAS/AOS Degree enrollment packet for your career field.

518-464-8500
fax: 518-464-8777
 or e-mail:
rcmilit@regents.edu

America's First Virtual University



Accredited by the Commission of Higher Education of the Middle States Association of Colleges and Schools, (215) 662-5606. Nursing programs are also accredited by the National League for Nursing Accrediting Commission 800-669-1656.

BRIEFINGS



Secretary of Defense William S. Cohen has announced that the president has nominated **Maj. Gen. Daniel J. Petrosky**, United States Army, for appointment to the grade of lieutenant general and assignment as commanding general, Eighth United States Army/Chief of Staff, United Nations Command/Combined Forces Command/United States Forces Korea, Korea. Since September 1996, he has served as the commanding general, United States Army Aviation Center and Fort Rucker, Fort Rucker, Ala.



The Chief of Staff, Army, has approved the assignment of **Brig. Gen. Anthony R. Jones**, from Assistant Division Commander (Maneuver), 1st Armored Division, United States Army Europe and Seventh Army, Germany, to commanding general, United States Army Aviation Center and Fort Rucker, Ala. Change of command is scheduled for September 23, 1998.

The U.S. Army Space and Missile Defense Command's Ballistic Missile Targets Joint Project Office has selected **Orbital Sciences Corporation (OSC)** to provide suborbital launch vehicles and related services in support of the Consolidated Theater Targets Services (CTTS) program. OSC said its contract for approximately 50 vehicles could exceed \$200 million during the first five years of the CTTS program.

The **Javelin Joint Venture** — a cooperative effort of Raytheon Systems Company and Lockheed Martin Corp. — has received a \$165 million Defense Department contract for continued full-rate production of the Javelin anti-tank missile system. The award, the second increment of a three-year contract, allows continued fielding of the fire-and-forget missiles to Army and Marine Corps units. Missile delivery is scheduled to begin in October 1999 and end in October 2000.

The **Pintite Corp.** has begun production of its "Can't Loosen" Clamp, a high-performance, stainless steel worm gear hose clamp. The clamp's design incorporates a patented positive locking assembly which prevents the clamp from loosening under vibration. The company has received inquiries of interest from every branch of the armed services, and predicts widespread aviation use of the device. Phone: (888) PIN-CLAMP Fax: (888) FAX-4-PIN

Initial integration of the **Rolls Royce/Turbomeca RTM 322** engine into British Army WAH-64 Apache helicopters is under way at The Boeing Company's Mesa, Ariz., facility. Britain's Ministry of Defence (MOD) has ordered 67 WAH-64s, each using RTM 322 engines and incorporating Longbow fire-control radars. Boeing's production of eight WAH-64 Apaches and partial assembly of the remaining 59 examples were scheduled to begin in Mesa in April, with GKN Westland undertaking final assembly, flight testing, and delivery and support operations at its Yeovil, England, facility. Boeing's first WAH-64 deliveries to GKN Westland are scheduled for late September, with first deliveries by GKN Westland to the MOD slated for early 2000.

Unit personnel, family members and friends of the **80th Transportation Company and 334th Trans. Detachment** will hold a 40th anniversary reunion October 8-11 in Seattle, Wash. In 1958 H-21 helicopters of the 80th Trans. Co., supported by the maintainers of the 334th Trans. Det., conducted a milestone long-distance flight from Fort Riley, Kan., to Fort Richardson, Alaska. The 80th then became the first helicopter company to be stationed in Alaska, and its members went on to establish several other important aviation and unit records. For further information on the reunion, contact Col. Don Kaiserman (Ret.) at (516) 744-9455 or (516) 468-9231.

The **Defense Technical Information Center** will hold its Annual Users Meeting and Training Conference Nov. 2 through 5 at the DoubleTree Hotel in Alexandria, Va. The point of contact for the conference is Ms. Julia Foscoe, Conference Coordinator, Directorate of User Services, Special Programs Branch, at (703) 767-8236.

EXTEX Ltd., the world's largest independent source of FAA-approved replacement parts for the Allison 250 turboshaft engine, has introduced an exchange program for replacement turbine nozzles for the widely used helicopter powerplant. The program permits the exchange of any used EXTEX nozzle or Allison's MAR-M-247 nozzle for \$500 credit toward the purchase of a new EXTEX nozzle. For more information contact EXTEX at (602) 988-2000 or visit them on the Web at www.extex.com.

Lear Siegler Services Inc. has won a U.S. Army Communications-Electronics Command/U.S. Air Force Air Logistics Center contract to provide integrated engineering, operational support, maintenance, repair or upgrade of systems belonging to the Department of Defense or any other federal agency. The new five-year "Rapid Response to Critical System Requirements" task-order contract has a total value of \$1.85 billion. Under the contract, Lear Siegler and its team of 20 companies will support all the military services' aircraft, tracked and wheeled vehicles, shelters, ground-support equipment and personnel. The support could include studies and analysis, technology insertion, systems modifications, new equipment installation, or the design and remanufacture of critical parts.

The military health care system's transition to Tricare has prompted many questions from military beneficiaries. To provide military families and retirees - including those age 65 and over - easy access to the most current information about a high-quality Defense Department-sponsored Tricare alternative, the **Uniformed Services Family Health Plan (USFHP)** has created an Internet website at www.usfhp.com. The site offers information about enrollment, coverage areas, benefits, patient care and other topics.

The Uniformed Services Family Health Plan (USFHP) has established a nationwide, toll-free information line to assist military families and retirees with USFHP enrollment information. The number is (888) 258-7347. The USFHP currently cares for more than 113,000 eligible family members of active-duty personnel, retirees and their family members (including those 65 and over) through seven not-for-profit civilian health systems in 11 states.

CORRECTION: The Army has awarded **Sabreliner Corp.** a contract for overhaul of cold section modules of the T700-GE-700 and T700-GE-701C gas-turbine engines currently used on the UH-60 Black Hawk and AH-64D Apache Longbow helicopters. The contract is a five-year min/max contract for 90 to 460 cold section modules with a maximum value of approximately \$35 million. The quantity under contract today is 110 modules. The work is being accomplished at the Sabreliner facility in Neosho, Mo.

The U.S. Army Aviation Center at Fort Rucker, Ala., was scheduled to have completed its comprehensive realignment of units, aircraft and basefields by the time this issue went to press. The effort - intended to increase efficiency, prepare for the arrival of future systems and reduce some costs - altered a system in place since 1987 and did not affect the installation's tenant activities. Primary changes included the transfer of all TH-67 Creek training helicopters from Lowe Army Helipport to Cairns Army Airfield; the consolidation of all UH-1 Iroquois, OH-58C Kiowas and UH-60 Black Hawks at Cairns; the realignment of classroom space and equipment; the reassignment to the realigned basefields of some 300 military and civilian contract instructor pilots; changes to the maintenance system supporting basefield operations; and some changes to flight corridor and stagefield usage. CH-47D operations at Knox Army Helipport will remain unchanged, as will Hanchey Army Helipport's AH-64A and OH-58D mission. Plans call for incoming AH-64D Longbow Apaches and RAH-66 Comanches to be based at Hanchey.

Alliant Techsystems' Defense Systems Group has delivered an Outrider tactical unmanned aerial vehicle system to the Army for assessment at Fort Hood, Texas. The Outrider system, which includes both air vehicles and ground-control stations, will be evaluated for its overall military utility. Outrider has already amassed more than 75 hours of flight time over some 85 flights, with the longest flight thus far lasting two hours and 32 minutes. Alliant's Defense Systems Group was selected in May 1996 to develop the Outrider under a two-year Advanced Concept Technology Demonstration program.

The Aerospace Industries Association, the trade group representing the nation's manufacturers of aerospace equipment, has named **John W. Douglass** as its new president and chief executive officer. Douglass, assistant secretary of the Navy for research, development and acquisition since Nov. 1, 1995, will take up his new duties in September.

The U.S. Army Air-to-Ground Missile Systems (AGMS) Project Office and Longbow LLC, a Lockheed Martin/ Northrop Grumman joint venture, have been named winners of the Order of Daedalians' Frank C. Wolfe Memorial Trophy for the Longbow Hellfire anti-armor missile program. The Daedalian award is presented annually by the armed services to groups or organizations judged to have contributed the most outstanding weapon system operating in the aerospace environment.

Two Dutch aviation enthusiasts have formed an organization dedicated to tracing the history, development and use of the AH-64 Apache helicopter. The Apache Research Group (ARG) will collect and disseminate unclassified information and photographs, and will create and maintain a database tracking the history of each AH-64. Individuals wishing to know more about the ARG and its goals may contact the group by FAX at (31) 40-221-2025 or by e-mail at grasedg@concepts.nl.

BG, GENERALS

Hackett, Craig D., 229 General Loop, Wahiawa, HI 98786.

COLONELS

Alvis, Michael W., P.O. Box 1951, Corvallis, OR 97339.
 Carter, Robert D., 203 W. Kingswood Dr., Enterprise, AL 36330.
 Elder, William J., 1060 Kaumoku St., Honolulu, HI 96825.
 Fletcher, Charles W., 180 S B St., Scott AFB, IL 62225.
 Muse, Gayland D., 7206 Squirrel Run Court, Springfield, VA 22152.
 Omlie, Austin R., 201 Somerset Pl., Enterprise, AL 36330.

Pillsbury, James H., 8303 Peach Ct, Fairfax Station, VA 22039.

Urbauer, Craig L., 5265 South Trimble Rd, Atlanta, GA 30342.

Walker, Paul C., 1401 Meadow Crest Ln, Mansfield, TX 76063.

LT. COLONELS

Anderson, David A., 1500 Berkeley Rd, Columbia, SC 29205.

Boyle, Thomas J., 2-502d Avn Regt, Unit 29719, APO AE 09028.

Briggs, Steven J., 1184 A Ferguson St, Fort Campbell, KY 42223.

Burch, James R. II, Box 620223, Fort Rucker, AL 36362.

Enderle, Richard A., 7th Bn 159th Avn Regt, CMR 416 Box 1502, APO AE 09140.

Gillis, Reginald R., 19 Gregg Way, Fort Rucker, AL 36362.

Goodale, John A., 537 Craig Rd, Carlisle, PA 17013. EM: goodalej@id-hgnat.army.mil

Grablin, Mark A., 14503 Storehouse Dr, Centerville, VA 22020.

Hilton, Cary A. Jr, HQ EUCOM, Unit 30400, Box 2292, APO AE 09128.

Miller, Richard, 1162 B Dent Ct, Fort Campbell, KY 42223.

Pallotta, Ralph, 15018 Carlisle Dr, Huntsville, AL 35803.

Roll, Darrell L., 2386A Ashcreek Drive, Scott AFB, IL 62225. EM: rolld@aol.com

Russell, Rick J., CMR 467, Box 6675, APO AE 09096.

Smith, Joseph A., 338 Lionshead Rd, Fayetteville, NC 28311.

Stuart, Leamond C., 101 Garden Walk, Stockbridge, GA 30281.

Wildes, David G., 4425 Airlie Way, Annandale, VA 22003.

Wolf, William T., 19 East Eppley Dr, Carlisle, PA 17013.

MAJORS

Bali, Daniel L., PSC 3, Box 2039, APO AP 96266. EM: bald@soback.kornet.Nm.Kr

Bedwell, Richard L., 1503 Pin Oak Court, No. 9, Radcliff, KY 40160.

Blackburn, Joseph W., 10 Diamond Circle, Fort Rucker, AL 36362. EM: blackbu@safty-emh1.army.mil

Darrow, Kelth R., 204 Pebble Creek Ln, Enterprise, AL 36330.

Dorf, Randal E., 2177 New England Place, Clarksville, TN 37043.

Eberle, Joann Y., 1507 22nd St So, Arlington, VA 22202.

Gehler, Christopher, 11 Meade Avenue, Apt. 3, Fort Leavenworth, KS 66027.

Gleisberg, Cynthia A., 700 Green Dr, Enterprise, AL 36330.

Hudon, Lisa A., 7883 N.W. Roanridge Road, Apt. K, Kansas City, MO 64151.

Jumper, Charles A., PSC 3, Box 1521, APO AE 09021. EM: charles.jumper@wpc.af.mil

Lehman, John H., HHC, 8th PERSCOM, Box 277, APO AP 95205. EM: LehmanJ@usfk.korea.army.mil

McLemore, Mark W., 1504 Preakness, Columbia, MO 65202.

Myers, Deborah A., 131 E. Arrowhead, San Antonio, TX 78228. EM: myers@huachuca-emh1.army.mil

Picciuto, John A. Jr., 1-2 Avn Regt, Unit 15008, APO AP 95208.

Rombough, Douglas H., 1514 Cedar Oaks Lane, Harker Heights, TX 76548.

Schoolcraft, David E., 47 Essex Court, Norristown, PA 19403. EM: deschoolie@aol.com

Switzer, Michael R., 5321 NW 83rd Place, Kansas City, MO 64151.

Tobin, Vincent M., 102 Bitterweed Ct, Madison, AL 35758.

Trang, Jeffrey A., 207 Hounds Chase, Yorktown, VA 23693.

Trankovich, John J., P.O. Box 576, Columbia, SC 29202.

CAPTAINS

Arbanas, Kevin A., 403 Hunter Pl., Hopkinsville, KY 42240.

Bheodari, Balram J., 210 Hidden Lake Drive, Fayetteville, GA 30215. EM: balram_bheodari@rucker-emh4.army.mil

Carroll, Richard G., 215 Glenwood Lane, Apt. 4, Enterprise, AL 36330.

Cochie, Kevin S., 3169 Stag Ct, Clarksville, TN 37043.

Collins, Micheal G., 2408 Raspberry Circle, Manhattan, KS 66502.

Fleher, Jeffrey J., Talon Chapter VP Programs, HHC, 11th Avn Regt, APO AE 09140. EM: 66cavb@email.ansbach.army.mil

Fleher, Scott T., 546 Stacey Weaver Drive, Fayetteville, NC 28311.

Gawkins, Michael J., U.S. Naval War College, 686 Cushing Rd, Newport, RI 02841.

LITEF

Black Hawk Gyro Replacement

LCR-92H "FOG" AHRS Retrofit in the UH-60

The LCR-92H is a solid-state strapdown "fog" (fiber optic gyro) AHRS (Attitude Heading Reference System) which replaces older mechanical gyros. A single LCR-92H replaces three older gyros in the UH-60 with a highly reliable, accurate & cost effective system. The retrofit can be accomplished with a minimum of effort, without altering aircraft wiring. An adapter harness mates with the aircraft connectors, and the mounting hardware uses existing mounting holes. The existing compass flux valve and cockpit control unit remain, and are utilized by the LCR-92H AHRS. The procedure is as follows:

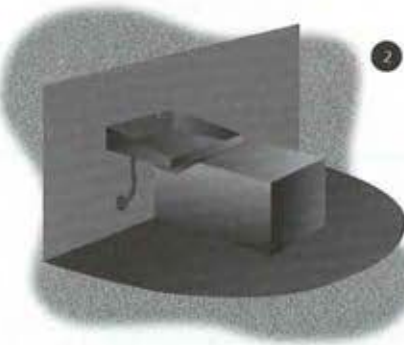
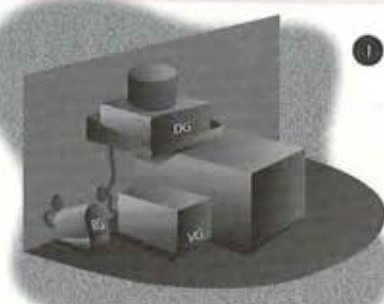

- Remove pilot side VG (CN-1314, CN-1497/A, or CN-811), the DG (CN-998) & the Rate Gyro (TRU-2/A)
- Bolt the connector mounting bracket of the adapter harness to top front of the DG shelf.
- Harness tie the VG, DG and Rate Gyro harnesses and reroute them to the connector mounting bracket.
- Plug the existing gyro connectors into the mating connectors on the mounting bracket.

- Install LCR-92H adapter plate and tray, utilizing existing three point VG mounting holes.
- Install LCR-92H AHRS in tray.
- Fasten D Sub connectors of mating harness to the LCR-92H AHRS.

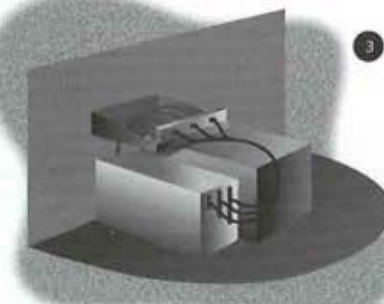

DAC
INTERNATIONAL

6702 McNeil Drive • Austin, Texas 78729
 512/331-5323, VOICE • 512/331-4516, FAX • 800/527-2531, U.S. • rmullinsr@aol.com, E-MAIL

Heartsfield, Bryan K., 5209 43rd Ct, Lacey, WA 98503.
Herrera, Salome, 1656 Barrywood Circle E., Clarksville, TN 37042.
Howard, Paul D., 5823 Kennedy Bridge Rd, Register, GA 30452. EM: howardp@ email.hanau.army.mil
Jernigan, David O., 3094 Nautilus Rd, Middleburg, FL 32068.
Kessler, Mark D., 542nd Med Co (AA), Unit 15705, Box 15, APO AP 96208.
Kimbrough, Robert S., 3110-E Paterson Loop, West Point, NY 10996. EM: shane@isye.gatech.edu
Lee, Jong-Hyuk, 1080 Ala Napunani St, No. 307, Honolulu, HI 96818.
Litvin, John F., W277 N2717 Chickory Ln, Pewaukee, WI 53072. EM: jlitvin@emh-4.korea.army.mil
Moffatt, James A., 912D Shepard Terrace, Paluxent River, MD 20670. EM: Tonyneasa@aol.com
Moreno, Kenneth G., PSC 303, Box 27, APO AP 96205. EM: morenok@usfk.korea.army.mil
Rhoades, Stephen L., 1650 Windriver Rd, Clarksville, TN 37042.
Rogers, Patrick C., 113 Woodrun Drive, Enterprise, AL 36330. EM: girogers1@aol.com
Scott, Tory L., 4087 Denning Spring, Apt. A, Fort Irwin, CA 92310.
Snow, David C., 1206 Academy St., Watertown, NY 13601.
Swift, Jennifer K., 78th Avn Bn 17th ASG CM, Unit 45013, APO AP 96338. EM: swiftj@email.ansbach.army.mil
Tingstrom, Peter B., 5831-A Brett Drive, Fort Knox, KY 40121. EM: sfranger77@aol.com
Ward, Warner R., HHC, 12th Avn Bde, CMR 467, Box 4325, APO AE 09096.
Zinili, Christopher, 12267 Wadsworth Way, Woodbridge, VA 22192.

1ST LIEUTENANTS

Baez, Francisco R., C Co. 1/501st Avn., CMR 477, Box 971, APO AE 09165.
Bell, James M., 3243 Tower Dr., Apt. C, Clarksville, TN 37042.
DeMott, Ron T., 162 Condor Ct, Clarksville, TN 37042.
Enos, Michel A., 94-739 Meheula Parkway, Apt. 11A, Miliani, HI 96789.
Green, Donald L., 2118 S. Virginia St, Hopkinsville, KY 42240.
Isaacson, Matthew L., HHT 1-6 Cav, Box 301, APO AP 96297. EM: misaacson@ala.naf
Phillips, David C., 215 N. Gladys, Apt. 1503, Leesville, LA 71446.
Rader, Matthew S., 528 Regency Dr, Apt. 301, Fayetteville, NC 28314.
Viles, Timothy C., 1536 Paisley Ave, Fayetteville, NC 28304.

2ND LIEUTENANTS

Adams, Jeffrey W., 100 Anthony Circle, Apt. 1, Enterprise, AL 36330.
Eckert, Jennifer L., 71 AM Windham Drive, No. 200, Daleville, AL 36322.
Fennema, Lee S., 111 Commons Dr, Enterprise, AL 36330.
Foerter, Jason A., 91 Coachman Drive, RD 1, Bordentown, NJ 08505. EM: x85107@ exmail.usma.edu
Ginos, Nathan D., 1500 Shellfield Road, Apt. 701, Enterprise, AL 36330.
O'Connell, Sean, 108 Willow Oaks Dr, Ozark, AL 36360.
Ridenhour, Heidi A., 4800 Rucker Blvd., No. 204, Enterprise, AL 36330.
Woelke, Nathan A., 144 Woodfield Pl, Enterprise, AL 36330.

CW5s

White, Dennis E., RR 1, Box 2255, Kempner, TX 76539.

CW4s

Lee, Robert D., 1111 Gip Manning Road, Clarksville, TN 37042. EM: apachedamo@men.com
Martin, John E., 300 S. Oakridge Dr, Enterprise, AL 36330.
Moring, Ronald, 10481 154th Rd N., Jupiter, FL 33478.
Patterson, John K., 94-1146 Poho Pl, Waipahu, HI 96797.
Underhill, Ronald L., 684 Old Zebulon Rd, Wendell, NC 27591.

CW3s

Framming, Eric D., 1001 N. Twin Creek Dr, #602, Killeen, TX 76543.

Novak, Robert J., OMC/AV Apache TAFT, Unit 64901, Box 16, APO AE 09839.
Stilwell, Keith E., 105 Dalfodil Cir, Madison, AL 35758.

CW2s

Davis, Guy E. Jr., 138 N. Harris Dr, Fort Rucker, AL 36362.
Hielsberg, Heath A., 3385 Timber Trace, Woodlawn, TN 37191. EM: heater64@hotmail.com
Kubli, Nikolas B., 1643 Windriver Rd, Clarksville, TN 37042.
Marler, Jeffery S., 311 Yvonne Dr, Enterprise, AL 36330.
Masters, John Roy, 12445 Deer Ridge Court, Holts Summit, MO 65043.
Wright, Jason K., A Co. 2/501 Avn Regt, CMR 477, Box 1486, APO AE 09165.

WO1s

Allgaier, Christopher, 28 Logan St., Fort Rucker, AL 36362.
Cavaco, Michael D., D Troop, 4/7 Cav, Unit 15038, Camp Stanton, APO AP 96251.
Crane, Michael D., 12300 Apache Ave, #309, Savannah, GA 31419.
Duran, David, 300 Coronada St, Enterprise, AL 36330.
Fisher, Andy G., 1001 Twin Creek Drive, Apt. 706, Killeen, TX 76543. EM: fisher@ n-link.com
Hogan, Tracy D., 122 Crestview Dr, Enterprise, AL 36330.
Humblingbird, Brandon W., 86 Woodfield Place, Enterprise, AL 36330.
Kolosick, Kristen Y., 92 Fannie Morris, Daleville, AL 36322.
Mitchell, Kevin D., 322 Dauphin St, Enterprise, AL 36330.
Pebsworth, Stanley D., 328 Candlebrook Dr, Enterprise, AL 36330.
Reynolds, Brent A., 1500 Shellfield R, #222, Enterprise, AL 36330.

ENLISTED SOLDIERS

Albee, Harold SGT, 891 Main St., #173, Walpole, MA 02061.
Alvarado, Ted SFC, 2105B Lolohe Ct, Wahiawa, HI 96786.
Berry, John J. MSG, 106 Kendall Dr, Newport News, VA 23601.
Carmichael, Chad R. SPC, HHC AMCOM, Box 1114, Redstone Arsenal, AL 35898.
Crumpler, Vernon L. SGT, 5628 Whitesell Rd, Louisa, VA 23093.
Graham, Tommie E. SFC, 12 Ardmoor Drive, Hampton, VA 23666.
Hillard, Larry E. SGT, 1389A Lance Street, Redstone Arsenal, AL 35807.
Machado, Anthony 1SG, 27 Marina Drive, Newport News, VA 23608.
McGrew, Paul W. SGT, 417-A Wright Avenue, Wahiawa, HI 96786.
Middleton, Dennis L. SFC, P.O. Box 4505, Fort Eustis, VA 23604.
Schiffman, James J. CSM, 4724 S. Parkway, Conroe, TX 77303.
Siebert, Hans MSG, 942 Woodcreek Drive, Newport News, VA 23608.
Taylor, William C. SPC, E Co., 5/158 Avn., CMR 467, Box 5734, APO AE 09096.
Vazquez, Orlando L. SPC, 9646-C Butler Loop, Fort Drum, NY 13602.
DACs
French, Mike L. Mr., 50 Silver Isles, Hampton, VA 23664.
Johnson, Edward T. Mr., 106 Rollingswood Road, Chesapeake, VA 23325.

CIVILIAN

Green, Charley, 443 E. Juniper Drive, Palatine, IL 60067.

RETIRED/OTHER

Harlor, Donald R. CW5, 275 Bantif Way, Petaluma, CA 94954. g3capt@aol.com
Kuhns, Albert W. CW4, 10 Crane Dr, Henrico, NC 27842.
Lennon, Bert L. COL, 715 Sutton Dr., Carlisle, PA 17013.
McCombs, James R. 1SG, 994 Blue Lantern Drive, Henderson, NV 89015.
Osborn, Ervin T. BG, 16740 S.E. Kelly St, Portland, OR 97236.
Stellar, Frederick W. LTC, 103 Provins Dr, Tullahoma, TN 37388.

Yes, We Admit It... We're Only Interested In Your Body.

Military and Commercial Repairs / Manufacturing

Specializing In:

**Honeycomb Bonded
Structure Repairs**

**Honeycomb Component
Replacements**

**Sheet Metal And
Structural Repairs**

**Consolidation And
Consignment Of Inventory**

Facilities:

Two Autoclaves

Testing Lab

**Chemical Processing Including
Phosphoric Acid Anodizing**

Titanium Processing

Clean Room

FAA / ODAR

FAA Repair Station HV2R886K

JAR 145

MIL-I-45208

**HELICOMB
INTERNATIONAL**

1402 South 69th East Avenue
Tulsa, Oklahoma 74112
(918)835-3999 FAX (918)834-4451
E-mail: hc@helicomb.com
Web site: helicomb.com



Aviation Branch Career News

The condensed lists presented below were extracted from PERSCOM's Web site. For up-to-the-minute news and the full text of the items extracted here, please refer to the PERSCOM Aviation Branch online newsletter at www.perscom.army.mil/opmd/avnews.htm and PERSCOM's "What's New" section at www.perscom.army.mil.

* = AAAA Members

FY98 Lieutenant Colonel Army Competitive Category Promotion Board Results

SEQ#	NAME	SEQ#	NAME	SEQ#	NAME	SEQ#	NAME
895	Alexander, David R.	557	Faupel, Thomas R.	871	Kodalen, Keith C.	215	Russell, Marvin N.
780	Balsh, Thomas A.	764	Finley, Henry L.	939	Larese, William S.	789	Schuroff, Louys P.
533	Ball, Arthur T.	665	Gaddis, Willie E.	586	Lauer, James J.	363	Selling, Brian R.
423	Barros, Roger J.	831	Gainey, Thomas K.	325	Layton, Daniel J.	168	Shaffer, Emmett C.
95	Bellows, Roderick A.	558	Garman, Patrick J.	90	Underman, Timothy	300	Smart, James A.
120	Blake, Harlan H.	199	Garrison, Michael E.	676	Loeffler, Andrew T.	781	Smidt, Jonathan J.
312	Bowler, Lynn N.	380	Genualdi, Dennis	675	Long, David S.	454	Sova, Robert J.
15	Bowlin, Harold C.	930	Georgia, Bruce A.	516	Mccaleb, Robert M.	599	Spencer, Michael A.
776	Boyer, Ricky R.	726	Greene, Keith D.	124	McNemey, Catherine	878	Steed, Roy D.
369	Brehm, Leslie M.	291	Gullot, Robert C.	361	Miller, Christopher	717	Stewart, Daniel S.
556	Brockman, Gregory A.	661	Hanson, Charles K.	201	Miller, James C.	993	Stewart, Michael D.
44	Burgess, Herbert L.	211	Hardy, Charles N.	109	Montgomery, Robert	940	Stockhausen, Richard
+1003	Buss, John C.	333	Hayes, Karen R.	982	Moore, Bruce	157	Stuckey, Barry L.
12	Campbell, Frederick	862	Hazelwood, Donald A.	+1040	Morris, William H.	465	Sumner, Wayne L.
197	Carroll, Carolyn A.	290	High, Steve W.	198	Murray, William E.	179	Sutton, Douglas M.
420	Ciluffo, Scott G.	332	Hodges, John S.	+1034	Muskopf, James A.	146	Terbury, Michael J.
214	Clymer, Peter E.	247	Howden, John M.	720	Nelson, Eric M.	213	Tionsong, Glenn D.
732	Colt, Jeffrey N.	280	Hunter, Robert G.	579	Netherland, Scott F.	165	Torrey, Samuel D.
691	Coyne, Eugene F.	501	Ingalls, Stephen A.	531	Paquette, Derek J.	844	Upright, James R.
473	Creamer, Timothy J.	456	Johnson, Brett E.	180	Parker, William E.	816	Veselicky, Frank
394	Crowell, Cynthia A.	142	Joiner, Michael A.	632	Pate, Maria C.	729	Westfall, Thomas F.
451	Davis, Dan J.	135	Jones, Jay R.	444	Pennycuik, Richard	37	Wirth, Walter M.
108	Depuglio, Michael P.	630	Karaus, John H.	447	Philbrick, Christopher	688	Wood, Charles H.
477	Devens, Christopher	926	Karr, Michael J.	230	Pierce, William A.	619	Wood, Paul J.
573	Dixon, Michael J.	874	Kelly, George G.	140	Pittman, Thurman M.	366	Yonts, James R.
588	Drake, Timothy E.	442	Keogh, Michael H.	694	Rainey, Walter P.	22	Yonts, Roger D.
721	Duncan, David E.	316	Kern, Russell J.	241	Reed, Charles R.		
497	Durham, Danny D.	711	Klatt, Kenneth W.	8	Rheinlander, Thomas		
977	Eberle, Joann Yvon	593	Klingels, Michael J.	377	Richardson, James M.		

FY98 CW5 Promotion Board Results (Aviator Warrant (Except 151A))

SEQ#	NAME	SEQ#	NAME	SEQ#	NAME	SEQ#	NAME
3	Andera, Donald G.	27	Gonsalves, George K.	25	Moring, Ronald C.	1	Skaaden, Richard A.
18	Anderson, George T.	24	Grissom, Allan L.	10	Muller, William C.	8	Struck, Thomas I.
5	Aslett, Zan D.	16	Johnson, Billy L.	19	Oates, James W.	4	Thorpe, Ricki K.
29	Bitecofer, Terrence	22	Jones, Keith J.	7	Ochranek, John A.	17	Wooten, Doyle N.
13	Borell, John R.	12	Larsen, Duane K.	23	Rhode, William F.	11	Wright, John D.
26	Collins, Raymond B.	31	Lucas, Harold F.	21	Roberts, Joseph C.	30	Zipolo, Gale E.
2	Eiland, Tommie L.	14	Moltenberry, John S.	20	Robertson, Gil H.		
9	El Terrence, F.	15	Moody, Ronald K.	28	Sangstad, Rodney L.		

Technical Services (Including Aviator Warrant 151A)

SEQ#	NAME
1	Moran, Homer L.

FY98 CW4 Promotion Board Results (Aviator Warrant except 151A)

SEQ#	NAME	SEQ#	NAME	SEQ#	NAME	SEQ#	NAME
174	Allred, Richard D.	79	Caprara, Robert A.	75	Durham, Mark J.	73	Glass, Charles R.
+203	Anderson, Alvin P.	4	Carr, Robert W.	45	Emery, Charles R.	187	Gloaves, Phillip G.
67	Arnold, David R.	6	Cavell, Brooks M.	41	Erwin, Jeffery W.	91	Gray, Steven G.
39	Astrup, John A.	35	Choate, Donald R.	+209	Evans, Richard	136	Gregorich, Henry J.
197	Badder, Frank C.	172	Chopra, Pramod P.	7	Fagan, Jeffery G.	50	Hammel, Paul D.
95	Baimforth, Dean S.	118	Clay, David Dee Jr.	59	Fall, Reed D.	55	Haney, Donald M.
1	Beal, Robert F.	62	Clegg, Michael E.	20	Farr, Dale G.	149	Hanks, Tommy W.
28	Beebe, Frederick R.	115	Cline, Kenneth W.	140	Flora, Brett R.	176	Hardy, James E.
+199	Bennett, Edward R.	48	Clough, Charles L.	166	Fletcher, Dennis M.	127	Harless, Hal G.
120	Bladinger, Steve S.	18	Collins, Tommy R.	85	Frabott, Terry L.	156	Haut, Daniel R.
+208	Blackstone, Bruce W.	44	Cook, Edward M.	169	Francis, Donald C.	90	Hawkins, Zane R.
163	Bland, Roy L.	101	Cook, George W.	135	Fremming, Eric D.	5	Hernandez, Eliseo G.
14	Boswell, Clint F.	+204	Cooper, David F.	108	Fry, Steven L.	36	Herrera, Pablo Jr.
42	Bourassa, Michael A.	22	Cooper, Jeffrey L.	74	Fuchs, Gregory P.	63	Higginbotham, K.
30	Bright, Robert D.	151	Dagostino, James R.	33	Gachupin, Samuel R.	121	Holan, Wray E.
83	Brown, Douglas B.	+198	Davis, Cleferd F.	96	Gamer, Michael S.	133	Holderby, James W.
159	Buck, Stanley J.	182	Day, Dodd M.	106	Garity, David P.	68	Hosley, Allen R.
71	Buckley, Richard A.	116	Denny, Scott	92	Gaston, David M.	+201	Houck, Timothy R.
124	Burhans, James R.	26	Detlefsen, Kevin M.	2	Georgeson, Alynn G.	24	Howard, Larry A.
143	Bushman, Frank G.	160	Dillon, Scott M.	29	Gerrish, Thomas W.	47	Hubacker, Mark E.
19	Cadwell, Neil St.	53	Duerst, Mark A.	164	Giacobbe, Louis S.	34	Huffman, Robert L.
109	Callahan, Brian D.	98	Duffy, John	147	Gideonse, Hendrik A.		<i>continued</i>

SEQ#	NAME
25	Jackley, Michael D.
157	Jackson, Thomas D.
21	Jaggers, David A.
61	Jensen, Kenneth C.
102	Joffion, Gregg A.
153	Johnson, George K.
144	Johnson, Ronnie L.
87	Jorgensen, Eric J.
89	Joyner, William G.
80	Keith, Stacy T.
167	Kelly, Quincy R.
32	Kenny, David A.
114	Killebrew, James H.
191	Klusacek, Ronald E.
16	Kreun, Warren D.
70	Lambert, Kerry L.
49	Lamont, Henri G.
110	Lansdowne, Kevin J.
112	Lasater, John M.
8	Leech, James R.
23	Lilleaas, Sveire
64	Lindgren, Dale C.
179	Lorenz, Scott A.
181	Lumley, David S.
12	MacDonald, Dana R.
122	Mallory, James P.
51	Martin, Carl R.
137	Mattingly, Troy D.
9	McArdle, Daniel C.
66	McCrea, Scott M.
69	McMahon, David J.
97	McSweeney, Eddie L.
107	Messerla, David M.
175	Miles, Robert E.
+207	Miller, Christopher
104	Miller, Retsae H.
78	Miller, Thomas I.
100	Milligan, David E.
17	Moinian, Shapour
13	Moorebrown, Dwight
150	Morgan, Gregory P.
178	Morrill, Sean
76	Morris, Edward G.
99	Morris, Steven A.
10	Morrison, Ross E.
184	Murdock, Mark M.
185	Musselwhite, Mark R.
129	Myers, James A.
77	Myres, Terrence A.
141	Navaro, Herbert R.
15	Northcutt, Tommy V.
+210	O'Donnell, Kirk A.
170	Ogburn, Marty W.
192	Olson, Marshall S.
126	Ottenbaker, Keith R.
93	Paasch, David H.
43	Pendley, Brian J.
196	Pennington, Coy J.
94	Peters, John M.
148	Petty, Robert D.
37	Phillips, Billy R.
189	Pratt, Michael J.
54	Pullen, Kenneth A.
11	Qualantone, Nicholas
173	Rhyne, Timothy N.
27	Richardson, Gary D.
131	Richie, James A.
+200	Riddle, Mark A.
139	Riffe, Daniel R.
119	Robinson, David A.
65	Salazar, Terry A.
113	Salemo, Anthony
+211	Sanders, Steven L.
56	Sandner, Tom
88	Shaffer, Robert E.
180	Shockney, Steven W.
81	Shroyer, Stephen M.
72	Sickels, Timothy A.
177	Smith, Brett C.
188	Smith, Gunder J.
145	Speller, Joel D.
165	Stille, Alfred
142	Stocker, Dennis L.
128	Stryker, Edmond L.
134	Sullivan, Billy E.
117	Swan, Howard L.
+205	Swann, David A.

COBRO MAINTENANCE SCIENCE SCHOLARSHIP

Parks College of Engineering and Aviation of Saint Louis University invites applicants for the Cobro Maintenance Science Scholarship to be awarded after November 1, 1998 for the semester beginning January 1999. The award will be for a minimum of \$19,000, renewable for up to three academic years.

APPLICANTS MUST HAVE:

- Achieved a 3.3 grade point average out of a possible 4.0 and have completed 60 semester hours or the equivalent at the college/university level.
- Contributed more than 50 percent of the cost of their college/university education from their own earnings (including military benefits).
- Completed at least one full year's employment in the avionics or a related industry (including military service).

Preference will be given to candidates who are U.S. citizens and who demonstrate a knowledge of computer-maintained databases, statistical inference analysis and an understanding of the key role of maintenance science and administration.

**Financial need is not a criterion.
Personal motivation is!**

DEADLINES FOR APPLICATION:

November 1, 1998, for Spring 1999 Semester.

May 1, 1999, for Fall 1999 Semester.

FOR MORE INFORMATION:

Dean Charles C. Kirkpatrick • Parks College of Engineering and Aviation
Saint Louis University • 3450 Lindell Boulevard • P.O. Box 56907
St. Louis, MO 63156 • (314) 977-8203 • www.slu.edu

**PARKS COLLEGE of ENGINEERING and AVIATION
SAINT LOUIS UNIVERSITY**

38	Sweatt, Gene E.	+206	Tutin, Lee M.	154	Whittemore, Daniel
195	Szad, Charles R.	146	Vallieres, Richard	111	Wilson, Michael L.
3	Tagstrom, Robert G.	105	Vanderweyden, Roder	190	Wilson, Thomas G.
171	Taylor, Guy M.	52	Vanlandingham, Kevin	183	Wojtala, Thomas J.
158	Taylor, Mark H.	130	Walker, Billy Joe J.	58	Wood, Gregory A.
46	Taylor, Norris H.	138	Walker, Robert D.	82	Wood, Stanley L.
161	Terrill, Gary R.	103	Wargo, Owen S.	132	Wyatt, George H.
123	Thelin, Todd C.	31	Weddington, Michael	193	Zernan, Matthew A.
57	Thetford, Richard R.	60	Weist, Michael E.		
162	Thurmond, William L.	40	Wells, Reuben Kim		
+202	Turberville, Gregory	152	Werner, Floyd S.		+ Below the Zone



Share your opinion on matters of interest to the Army aviation community. The publisher reserves the right to edit letters for style, accuracy or space limitations. All letters must be signed and authors identified. The publisher will withhold the author's name upon request. The opinions expressed are those of the authors, and do not reflect the opinion of ARMY AVIATION Magazine. Send letters to AAAA MAILBOX, 49 Richmondville Ave., Westport, CT 06880-2000, Tel: (203) 226-8184, FAX: (203) 222-9863, E-Mail: aaaa@quad-a.org.

"We Care About Training"

The article "Who Cares About Training" in the July issue of Army Aviation contains errors and requires clarification.

The Aviation PEO and subordinate project managers are directly responsible for the execution of Army funds. Planning and programming are the responsibility of the Army Staff, OSD, and Congress. A PM cannot "divert" congressionally directed funding. TRADOC, and not ODCSOPS, determines materiel requirements. And ODCSOPS, not the PM, prioritizes materiel requirements.

The article would have been more appropriately titled, "Why are Training Simulators Deficient?" The article does not mention maintenance trainers — a huge success story. No mention is made of New Equipment Training — another Aviation area of excellence. And no mention is made of the funding reductions to the flying hour program, perhaps aviation training's greatest challenge. While we are concerned with the condition of our manned simulators, we understand they are competing for scarce resources.

Money is a problem. Aviation's buying power has been reduced by 74 percent over the last decade. In FY 00 aviation will have the smallest procurement account of any of the major accounts, except ammo. In this environment, all money moves are zero-sum operations, to include congressional plus-ups. We cannot fund anything new without giving up funds elsewhere. While one may applaud the author's referenced plus-up for a geo-specific database, we can be assured it was resourced at the expense of another Army priority.

The future budget outlook indicates more cuts are on the way. In this environment, aviation is developing a true Army After Next system, Comanche; fielding a true leap-ahead capability in Longbow Apache; starting EMD on the Improved Cargo Helicopter; buying new UH-60s; and maintaining readiness rates well above DA goals for the active fleet.

It is an insult to the dedication and professionalism of our military and civilian PEO team to state they don't have the understanding or expertise to contribute to the training of line pilots. Many officers and civilians in the PEO are combat veterans, most with current and past operational flying experience. To imply their sole interest is how they are graded on evaluations, and not on meeting the needs of soldiers, is far from the truth. Examples of intense PM interest in training are the ongoing, near flawless fielding of the Longbow Apache to Fort Hood and the production of the Longbow Crew Trainer scheduled for fielding in FY 99, both results of user-PM partnership in training.

As to the assertion by the author that the AMCOM commanding general and I are doing a poor job of managing our PMs in the area of simulators, I will accept that criticism on my behalf only. But, we all are trying to do better. Following the Aviation Center's leadership AMCOM, PEO Aviation, Army National Guard, STRICOM and DA have been working together to try to find funding for Aviation's manned simulator strategy. All have contributed toward the AVCATT effort. Bottom line: We care about training.

Maj. Gen. James R. Snider

Dear Editor:

The sun shines bright on Army aviation today.

As an old time Army Aviator with happy memories of the late 1960's and early 1970's when there were over 10 Lt. Generals and a bunch of major generals wearing wings on active duty, I have been "belly aching" about the dearth of Army aviators in command and key positions. This past summer I visited Fort Carson, Colo. The visit was enlightening and heart lifting.

I knew the commanding general was an Army aviator having met him at the Aviation Leaders Conference at Fort Rucker in February. During my brief visit I learned that since September 1997 through August 14, 1998 Fort Carson's commanding general, deputy commanding general and chief of staff have all been Army aviators. The roster is:

- CG—MG John M. Riggs AV
- DCG—BG John K. Schmitt AV
- C/S—Col. Dennis L. Cripps AV (retired 20 July)
- C/S—Col. Randal M. Tieszen AV (replaced Col. Cripps)

In addition to the above, I learned that their boss, the new III Corps Commander, Lt. Gen. Leon J. LePorte, wears Army aviator wings.

To really put the icing on the cake I just learned that Ron Adams, a previous Branch Chief, and Dan Petrosky, the present Branch Chief, are being promoted to Lt. Generals.

Today's Army aviators make all of us old timers very proud of you.

Robert R. Williams
Lt. Gen. U.S. Army (Ret)

Dear Editor:

"Who Cares About...?"

In his July article "So, Who Cares About Training?" Matthew R. Kambrod presented a vividly true picture of the sad state of our aviation simulation training devices. He has clearly hit on some very key issues that need to be addressed now and about which appropriate actions need to be taken. Beyond the poor condition of the devices, however, is the frightening debasement of the training personnel positions. Those trainers are the very people that instruct our aircrews.

What has been happening recently is that there are a number of unqualified Department of the Army civilian (DAC) personnel now imparting Aircrew Training Manual (ATM) instruction to all manner of aviators (Army, allied and other). These people have been classified in the Civil Service GS-1712 job series in grades 9 through 13. Some have job descriptions that clearly allow the gamut of flight instruction at all levels. The problem is that some of these DACs are not even rated aviators, others are not rated in the particular aircraft for the flight simulator they are instructing about, and others are not instructor pilots and/or instrument flight examiners.

The question begging to be asked is: "How is anyone able to enact the duties of a fully qualified instructor pilot or instrument flight examiner if they are not so qualified?" I cannot answer that question.

The Directorate of Evaluation and Standardization (DES) at Fort Rucker is fully empowered to conduct standardization functions at all levels of Army aviation, and regularly does so worldwide. The one issue in which DES has no say, however, is DAC job classification. Simply "classifying" someone to do certain things does not mean that person is qualified to do those tasks. In the case presented here personnel are clearly being "misclassified" and certainly "misutilized." Giving an unqualified person the "pseudo-license" of an instructor pilot or instrument flight examiner destroys the very essence of the standardization program, opens the door to increasingly deficient training and seriously jeopardizes the safety of our aircrews.

Yes, we most definitely need the best equipment updated to the latest configurations, but we also need qualified personnel to do the training. So, who cares about training? Well, it better be every last one of us, because training is the only proven way of providing proficient and safe combat-ready aviators.

CWO 4 Gary W. Helmer (Ret.)

PICTURES AND NAMES OF THE 1998 AAAA
SCHOLARSHIP RECIPIENTS APPEAR ON THE
PAGES THAT FOLLOW

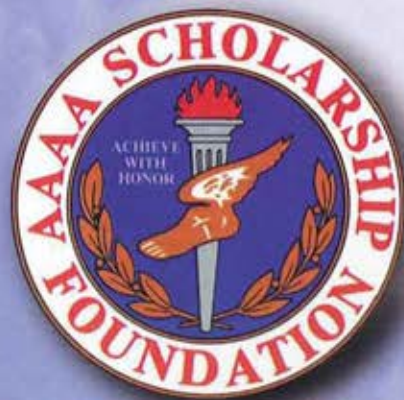

EDUCATION

THE WEAPON OF CHOICE

in the strategy for success

Congratulations to the 82 recipients of 1998 AAAA educational grants and loans! These award winners were selected from more than 200 applicants to receive more than \$182,000. With this financial assistance, these students will be armed with the educational weapons needed to succeed and to help make their dreams come true.

**For more information
and scholarship
applications, contact:**

**AAAA Scholarship
Foundation, Inc.**
49 Richmondville Ave.
Westport, CT 06880-2000
(203) 226-8184
Fax: (203) 222-9863
aaaa@quad-a.org

Thanks to the very generous support of AAAA members, corporate contributions, and AAAA chapter fundraising efforts, 1998 had the largest number of award winners and the greatest amount of money ever awarded in a single year since the AAAA Scholarship Foundation was formed in 1963.

Individual and corporate contributions to the AAAA Scholarship Foundation are tax deductible. Opportunities to contribute include one-time donations, memorial scholarship and permanently funded grants. Contributions also are taken through the Combined Federal Campaign.



\$180,000 in Scholarships To Benefit AAAA Members

MG Robert S. Frix, Ret.

President, AAAA Scholarship Foundation, Inc.

One of AAAA's greatest membership benefits, the AAAA Scholarship Program continues to get bigger and better. This year we awarded a record \$180,000.00 to a record number of outstanding students. The 82 students on the next few pages are related to AAAA members ranging from enlisted to general officers. Another record was set as 17 students were related to or were Aviation Warrant Officers. In general, five members themselves, eight spouses, and 65 children of members won awards.

Thirty graduate, 68 upperclassmen, and 103 freshmen applicants competed for awards this year. 33% of the graduate, 40% of the upperclassmen, and 44% of the freshmen applicants won awards.

The average Quality point averages of the graduate winners was 3.84; upperclassmen winners - 3.76; and an astounding 3.96 for freshmen.

Keep in mind that this is a merit based ONLY scholarship program. The Awards Board under the direction of its chairman, MG Tom Garrett, is run with complete integrity. All names of the applicants and the ranks and names of their AAAA member relatives are removed from the files before they are boarded. Financial need is not considered and no references to finances are included in the files.

Furthermore, 100% of your donations is applied to scholarship principal and awards. All expenses are generously underwritten by the Army Aviation Association of America, Inc. in order to allow the AAAA Scholarship Foundation, Inc. to operate at 100% efficiency!

We are very proud of these students. Please join us in celebrating their excellence.



AAAA National Scholarship - \$15,000 (\$3,750 a year for four years) Zeb M. Kaylor, son of CW4 R. S. Kaylor (Ret.), Fayetteville, NC - North Carolina State.



The GEN Frank S. Besson, Jr. Memorial Scholarship - \$15,000 (\$3,750 a year for four years) Brendan J. Dixon, son of Ms. Joanne E. Dixon, Pasadena, CA - Stanford University.



The LTG William B. Bunker Memorial Scholarship - \$15,000 (\$3,750 a year for four years) Michael J. Siverd, son of Dr. Jim Siverd, Madison, AL - Massachusetts Institute of Tech.



The BG Robert M. Leich Memorial Scholarship - \$5,000 (\$1,250 a year for four years) Johnathan D. Thill, son of CW4 David C. Thill, Ret., Enterprise, AL - Auburn University.



The BG O. Glenn Good-hand Memorial Scholarship - \$5,000 (\$1,250 a year for four years) Karen J. Vreeman, daughter of CW4 Timothy J. Vreeman, Ret., Lakewood, WA - Dordt Coll



The Bryce Wilson Memorial Scholarship - \$5,000 (\$1,250 a year for four years) Jade N. Grimmus, daughter of SSG Douglas L. Grimmus, Albany, OR - Brigham Young University.



The AAAA National Scholarship (Aeronautical) - \$4,000 (\$1,000 a year for four years) Joseph M. Bazzetta, son of Jerry M. Bazzetta, St. Louis, MO - St. Louis University.



The Monmouth Chapter (Hogelin/O'Donnell Memorial) Matching Scholarship - \$4,000 (\$1,000 a year for four years) Jeffrey R. Pribyl, son of Richard E. Pribyl, Eatontown, NJ - Duke University.



The North Texas Chapter Matching Scholarship - \$4,000 (\$1,000 a year for four years) Stephanie E. Patterson, daughter of CW4 Clifton E. Patterson, Ret., Arlington, TX - Texas A&M Univ.



The Tennessee Valley Chapter (Colleen Hipp) Matching Scholarship - \$4,000 (\$1,000 a year for four years) Erica N. Moore, daughter of LTC Steven R. Moore, Madison, AL - Univ. of Missouri.



The Central Florida Chapter Matching Scholarship - \$3,000 (\$1,500 a year for two years) Benjamin J. Kravitz, son of Len R. Kravitz, Orlando, FL - Boston University.



The Monmouth Chapter (B. Howard Dean/Ken K. Kelly) Matching Scholarship - \$3,000 (\$1,500 a year for two years) Eric E. Sharret, son of Igal P. Sharret, Eatontown, NJ - Princeton University.



The Helen Cribbins Memorial Scholarship - \$3,000 (\$1,500 a year for two years) Lauren A. Stearns, daughter of LTC David M. Stearns, Enterprise, AL - Furman University.



The Joseph P. Cribbins Scholarship - \$3,000 (\$1,500 a year for two years) Andrew C. Lebsack, son of MAJ Dale E. Lebsack, Ret., Enterprise, AL - Troy State University.



The Central Florida Chapter Matching Scholarship - \$2,000 (\$1,000 for two years) Jacob P. Birmingham, son of LTC Robert P. Birmingham, Orlando, FL - University of Central Florida.



The Flying Tigers Chapter Matching Scholarship - \$2,000 (\$1,000 for two years) Jonathan N. Mand, son of Lawrence R. Mand, New Albany, IN - Purdue University.



The Savannah Chapter Matching Scholarship - \$2,000 (\$1,000 for two years)
Heather R. Hungerford, daughter of MAJ Dale A. Hungerford, Ret., Savannah, GA - Armstrong Atlantic State University.



The Donald F. Luce Corporate Matching Scholarship - \$2,000 (\$1,000 for two years)
Susan M. Tomaine, daughter of Robert L. Tomaine, Huntsville, AL - Georgetown Univ.



The Monmouth Chapter Matching Scholarship - \$2,000 (\$1,000 for two years)
Anna C. Oleinik, daughter of Leonid Oleinik, Ocean, NJ - Rutgers State University.



The Monmouth Chapter (Kahl Winter) Matching Scholarship - \$2,000 (\$1,000 for two years)
Juan C. Quinones, son of Patrick A. Quinones, Brick, NJ - Rutgers State University.



The Lindbergh Chapter Matching Scholarship - \$1,500 (\$1,500 for one year)
Michael S. Whitaker, son of John M. Whitaker, Florissant, MO - University of Missouri.



The Phantom Corps Chapter (Coldwell Banker) Matching Scholarship - \$1,500 (\$1,500 for one year)
Adam L. Golson, son of LTC Ellis W. Golson, Harker Heights, TX - University of Alabama.



The AAAA National Scholarship - \$1,500 (\$1,500 for one year)
Justin A. Kromets, son of CW4 Jerry A. Kromets, Ozark, AL - Virginia Tech.



The Jane & Wayne Phillips Memorial Scholarship - \$1,500 (\$1,500 for one year)
Guy A. Rogers, III, son of LTC Guy A. Rogers, II, Fort Leavenworth, KS - Texas A&M University.



The AAAA National Scholarship - \$1,500 (\$1,500 for one year)
Megan L. Galbreath, daughter of LTC Durward H. Galbreath, Ret., Essex Junction, VT - University of Vermont.



The Air Assault Chapter Matching Scholarship - \$1,000 (\$1,000 for one year)
Lisa G. Lynch, wife of CW4 Brian E. Lynch, Ret., Clarksville, TN - Austin Peay State University.



The Aviation Center Chapter Matching Scholarship - \$1,000 (\$1,000 for one year)
Leslie E. Redington, daughter of John V. R. Redington, Enterprise, AL - Rhodes College.



The Aviation Center Chapter Matching Scholarship - \$1,000 (\$1,000 for one year)
Misty Y. Boaz, daughter of MW4 James M. Boaz, Ret., Enterprise, AL - University of Alabama.



The Aviation Center Chapter Matching Scholarship - \$1,000 (\$1,000 for one year)
Brandy A. Burhans, daughter of CW3 James R. Burhans, Fort Rucker, AL - Bradley University.



The Cedar Rapids Chapter Matching Scholarship - \$1,000 (\$1,000 for one year)
James J. Utley, son of LTC James L. Utley, Ret., Peachtree City, GA - Auburn University.



The Colonial Virginia Chapter Matching Scholarship - \$1,000 (\$1,000 for one year)
Tracy M. Braddy, daughter of COL William L. Braddy, Jr., Chesapeake, VA - Univ. of North Carolina.



The Greater Atlanta Chapter Matching Scholarship - \$1,000 (\$1,000 for one year)
Sharon A. Vanarsdale, daughter of COL Michael J. Vanarsdale, Ret., Peachtree City, GA - University of Georgia.



The Monmouth Chapter (Ablett/Gobel Memorial) Matching Scholarship - \$1,000 (\$1,000 for one year)
Alexander Cortez III, son of Alexander Cortez, Jr., Howell, NJ - LaSalle University.



The Tennessee Valley Chapter Matching Scholarship - \$1,000 (\$1,000 for one year)
Sara C. Vins, daughter of LTC Joseph J. Vins, Ret., Madison, AL - University of Maryland.



The Washington-Potomac Chapter (Robert F. Molinelli) Matching Scholarship - \$1,000 (\$1,000 for one year)
Justin T. Wills, son of LTC Thomas G. Wills, Woodbridge, VA - Virginia Polytechnic Institute.



The Washington-Potomac Chapter Matching Scholarship - \$1,000 (\$1,000 for one year)
Kelly M. Newsome, daughter of COL Charles H. Davis, Gaithersburg, MD - University of Maryland.



The Washington-Potomac Chapter Matching Scholarship - \$1,000 (\$1,000 for one year)
MSG Tanya R. Whitney, Dale City, VA - Embry Riddle Aeronautical College.



The CW3 Stephen A. Hansen Memorial Scholarship - \$1,000 (\$1,000 for one year)
Teresa M. Rini, daughter of COL Thomas J. Rini, Seoul Korea - Boston College.



The Army Aviation Publications, Inc., Corporate Matching Scholarship - \$1,000 (\$1,000 for one year)
Kyrath M. Davis, daughter of LTC Gary R. Davis, Ret., Mullica Hill, NJ - Rosemont College.



The DynCorp Corporate Matching Scholarship - \$1,000 (\$1,000 for one year)
Laura L. Finder, daughter of CW3 Adolph J. Finder, Ret., Mount Vernon, MO - Georgia Institute of Technology.



The Raytheon Corporate Matching Scholarship - \$1,000 (\$1,000 for one year)
Jennifer L. Grafton, daughter of Daniel A. Grafton, Madison, MS - William Carey College.



The Igor Sikorsky Memorial Corporate Matching Scholarship - \$1,000 (\$1,000 for one year)
Kelly L. Maynard, daughter of Charles B. L. Maynard, Wallingford, CT - Tufts University.



The Westar Corporate Matching Scholarship - \$1,000 (\$1,000 for one year)
Chad T. Hoffman, son of MAJ Floyd T. Hoffman, Ret., O'Fallon, MO - Anderson University.



The AAAA Spouse Scholarship - \$1,000 (\$1,000 for one year)
Rebecca S. Mullin, wife of CPT Patrick J. Mullin, Waipahu, HI - University of Hawaii.



The AAAA Spouse Scholarship - \$1,000 (\$1,000 for one year)
Kelly R. Kerrigan, wife of CPT Shawn R. Kerrigan, Glen Allen, VA - J. Sargeant Reynolds Community College.



The AAAA Company Grade Officer Member Scholarship - \$1,000 (\$1,000 for one year)
CPT Ronald G. Shashy, Ocala, FL - University of South Florida.



The AAAA Company Grade Officer Member Scholarship - \$1,000 (\$1,000 for one year)
CPT Jeffrey A. Walsh, Converse, TX - St. Mary's University.



The AAAA Warrant Officer Member Scholarship - \$1,000 (\$1,000 for one year)
CW4 Thomas N. Lloyd, Ret., Ankeny, IA - Iowa State University.



The AAAA Warrant Officer Member Scholarship - \$1,000 (\$1,000 for one year)
CW2 Matthew E. Luther, Honolulu, HI - Regis University.



The AAAA Enlisted Member Scholarship - \$1,000 (\$1,000 for one year)
SPC John W. James, Logan, UT - Utah State University.



The AAAA Enlisted Member Scholarship - \$1,000 (\$1,000 for one year)
SFC Lisa R. Morgan, Wahiawa, HI - Chaminade University of Honolulu.



The AAAA Department of the Army Civilian Member Scholarship - \$1,000 (\$1,000 for one year)
Mary Anne Woytus, St. Peters, MO - University of Missouri.



The AAAA Department of the Army Civilian Member Scholarship - \$1,000 (\$1,000 for one year)
Rita P. Lozano, Corpus Christi, TX - Delmar College.



The COL D. L. Bristol Memorial Scholarship - \$1,000 (\$1,000 for one year)
Megan K. Kelley, daughter of LTC John M. Kelley, Ansbach, Germany - Drake University.



The Leo E. Bergeron AAAA Life Member Memorial Scholarship - \$1,000 (\$1,000 for one year)
Colin C. Murchie, son of Gates S. Murchie, Vestal, NY - Cornell University.



The AAAA National Scholarship - \$1,500 (\$1,500 for one year)
Sienna L. Moran, daughter of CPT Stephen R. Moran, Huntington, NY - Drew University.



The AAAA National Scholarship - \$1,000 (\$1,000 for one year)
Kelli S. Hancock, daughter of LTC Rickie D. Hancock, Ret., Windham, NH - Valparaiso University.



The AAAA National Scholarship - \$1,000 (\$1,000 for one year)
Lisa M. Roll, daughter of LTC Darrell L. Roll, Lebanon, IL - Illinois College.



The AAAA Upperclassman Scholarship - \$1,000 (\$1,000 for one year)
Pamela R. Horn, daughter of Charles I. Horn, St. Louis, MO - St. Louis University.



The AAAA Upperclassman Scholarship - \$1,000 (\$1,000 for one year)
Rachael B. Novier, daughter of COL Frank H. Novier, Fort Sam Houston, TX - Texas Tech University.



The AAAA Upperclassman Scholarship - \$1,000 (\$1,000 for one year)
Anna L. Matusiewicz, daughter of LTC Daniel A. Matusiewicz, Ret., Jackson, MS - University of Mississippi.



The AAAA Upperclassman Scholarship - \$1,000 (\$1,000 for one year)
Jason P. York, son of MAJ Michael J. York, Fort Leavenworth, KS - Tulane University.



The AAAA Upperclassman Scholarship - \$1,000 (\$1,000 for one year)
Kisti B. Cadwell, daughter of CW3 Neil S. Cadwell, Colorado Springs, CO - Lubbock Christian University.



The AAAA Upperclassman Scholarship - \$1,000 (\$1,000 for one year)
Erin M. Whitaker, daughter of John M. Whitaker, Florissant, MO - Trinity University.



The AAAA Upperclassman Scholarship - \$1,000 (\$1,000 for one year)
Angela M. Panahi, wife of SSG Ramin H. Panahi, Fort Rucker, AL - Troy State University.



The AAAA Upperclassman Scholarship - \$1,000 (\$1,000 for one year)
Kathleen C. Smalligan, daughter of Paul Smalligan, Alamo, CA - Pomona College.



The AAAA Upperclassman Scholarship - \$1,000 (\$1,000 for one year)
Jessica A. Paramore, daughter of LTC Jerry S. Paramore, Ret., Macon, GA - University of Georgia.



The AAAA Upperclassman Scholarship - \$1,000 (\$1,000 for one year)
Kristin D. Lindsey, daughter of G. Dwight Lindsey, Dothan, AL - University of South Alabama.



The AAAA Upperclassman Scholarship - \$1,000 (\$1,000 for one year)
Sarah B. St. Jean, wife of MAJ A. Christopher St. Jean, Williamsburg, VA - Thomas Nelson Community College.



The AAAA Upperclassman Scholarship - \$1,000 (\$1,000 for one year)
Jennifer N. Alfaro, daughter of LTC Miguel Alfaro, Ret., San Antonio, TX - Our Lady of the Lake University.



The AAAA Upperclassman Scholarship - \$1,000 (\$1,000 for one year)
Nicholas J. Livak, son of LTC Heldur Liivak, Hampton, VA - Virginia Commonwealth University.



The AAAA Upperclassman Scholarship - \$1,000 (\$1,000 for one year)
Dale S. Rogers, wife of CW2 Jack V. Rogers, II, Ret., Dallas, TX - Tarleton State University.



The AAAA Upperclassman Scholarship - \$1,000 (\$1,000 for one year)
Kathy J. Crisp, wife of MSG Dennis D. Crisp, Ret., Enterprise, AL - Troy State University.



The AAAA Graduate Scholarship - \$1,000 (\$1,000 for one year)
Amy E. Hedges, daughter of CW4 John R. Hedges, Ret., Cornwall-on-Hudson, NY - Eastern Virginia Medical School.



The AAAA Graduate Scholarship - \$1,000 (\$1,000 for one year)
Danielle M. Wise, daughter of CW5 James F. Wise, Fayetteville, NC - University of North Carolina.



The AAAA Graduate Scholarship - \$1,000 (\$1,000 for one year)
Deborah R. Bainbridge, wife of CW2 Shawn A. Bainbridge, Stockton, CA - University of the Pacific.



The AAAA Graduate Scholarship - \$1,000 (\$1,000 for one year)
Megan K. Yunghans, daughter of LTC Richard L. Peters, Ret., Orlando, FL - University of Miami.



The AAAA Scholarship Interest-Free Loan - \$4,000 (\$1,000 a year for four years)
Adam C. Jerauld, son of LTC(P) Gary D. Jerauld, St. Charles, MO - University of Maryland.



The AAAA Scholarship Interest-Free Loan - \$4,000 (\$1,000 a year for four years)
Carrie E. Rees, daughter of MG Raymond F. Rees, Salem, OR - Western Washington University.



The AAAA Scholarship Interest-Free Loan - \$4,000 (\$1,000 a year for four years)
Mary C. Konitzer, daughter of BG Thomas J. Konitzer, Ret., Evans, GA - Vanderbilt University.



The AAAA Scholarship Interest-Free Loan - \$4,000 (\$1,000 a year for four years)
Elizabeth B. Motley, daughter of LTC Campbell M. Motley, Ret., Woodbridge, VA - Virginia Polytechnic Institute.



The AAAA Scholarship Interest-Free Loan - \$4,000 (\$1,000 a year for four years)
Sarah M. Sled, daughter of CW2 Thomas Sled, Ret., Grover Beach, CA - University of California, Berkeley.

● CFC ● CFC ● CFC ● CFC ● CFC ● CFC ●



The AAAA Scholarship Foundation, Inc. (AAAASFI) is now part of the Combined Federal Campaign (CFC), a workplace charitable fund drive conducted by the U.S. Government for all federal employees. It is the single largest workplace fund drive in the country, raising approximately \$195M in pledges annually.

Please consider making a CFC-sponsored contribution to the AAAA Scholarship Foundation this year.



Editor's Note: Army Aviation is seeking good-news announcements of aviation-related professionals who are on the move. If you or your organization have an upcoming change of leadership (at the battalion or squadron level, or higher for MTOE and TDA units), please forward the information to Barbara Ross, care of the AAAA National Office.

Robert Szerszynski has been selected as the first AAC Competitive Development Group (CDG) for PM. Bob is a member of YG97 CDG program and is assigned to a developmental assignment at the U.S. Army Test and Evaluation Command in Aberdeen Proving Ground, Maryland. He is currently a student at the Advanced Program Management Course at the Defense Systems Management College. Mr. Szerszynski was the Only DAC selected in this first ever truly combined military/civilian PM selection board. He is a Life Member of AAAA, and has worked in Army Aviation for more than 15 years.

Col. Davis D. Tindoll, Jr. has been named Chief of Staff for the US Army Aviation Center and Fort Rucker. Tindoll was serving as the Director of Plans, Training, Mobilization, and Security at Fort Rucker when selected as the interim Chief of Staff. **Col. Robert D. Carter** succeeded Tindoll to become the new Director of Plans, Training, Mobilization, and Security effective July 8.

Lt. Col. James S. McGhee assumed the duties of Dean of the US Army School of Aviation Medicine at Fort Rucker from **Col. John M. Blough** on Aug. 10. McGhee recently departed as the Chief of the Department of Primary Care, DeWitt Health Care System at Fort Belvoir, Va. Blough, who has served as the Dean for the past two years, retires after 28 years of service and plans to practice medicine in Arton, Ala.

Command Sgt. Maj. Dianne Williams, assumed responsibility from **CSM John E. Lawrence** as the Command Sergeant Major of the Aviation Training Brigade at Fort Rucker on August 31. Williams previously served as the CSM of 164th Air Traffic Services Group in the Republic of Korea. Lawrence, who has served as the ATB CSM since May 1, 1997, retires after 30 years of service.

Brig. Gen. Craig D. Hackett has been named as the new Assistant Division Commander (support) of the 25th Infantry Division (Light) in Hawaii. Hackett has been serving as the Director of Integration, Office of the Assistant Deputy Chief of Staff for Operations and Plans for Force Development in Washington D.C. since August 1997.

Brig. Gen. Dell L. Dailey, will move from Assistant Division Commander, 101st Airborne Division (Air Assault), Fort Campbell, Kentucky to Director, Requirements and Strategic Assessments, J-7, US Special Operations Command, MacDill Air Force Base, Fla. Date to be determined.

New Chapter Officers

Aloha:

CWO 4 Jeff Elmore, VP for Warrant Officers.

Army Aviation Center:

Capt. Edward W. Rhinier, VP Scholarships; Cmd

Sgt Maj. Sanford C. Tanna, Vice President

Enlisted Affairs; Col. Gary N. Matteson,

USAAMC Representative.

Colonial Virginia:

Lt. Col. John S. Kane, Senior Vice President.

Morning Calm:

Maj. Bruce J. Gorski, Secretary.

Nile Delta:

CWO 3 Robert J. Novak, President.

Oregon Trail:

CWO 3 Joseph P. Mollahan, Treasurer.

Ragin' Cajun:

Capt. Scott P. Ditto, Treasurer; CWO 3 Thomas

D. Lawson, VP Membership.

Stonewall Jackson:

CWO 3 Wayne T. Martell, Treasurer.

Sinai:

Capt. Ronald E. Richards, Jr., Secretary.

Spec. Orlando L. Vazquez

July 1998

(North Country Chapter)

AAAA Soldiers of the Quarter

A Chapter Program to Recognize Outstanding Aviation Instructors on a Quarterly Basis

SSgt. Timothy K. Bahadar

3rd Quarter FY98

(Colonial Virginia Chapter)

Spec. Timothy C. Crosby

3rd Quarter FY98

(Aviation Center Chapter)

AAAA NCO of the Quarter

A Chapter Program to Recognize Outstanding NCOs on a Quarterly Basis

Sgt. Richard S. Adams

3rd Quarter FY98

(Aviation Center Chapter)

Honorary AAAA Members

Maj. Gen. Roger C. Schultz

New AAAA Industry Members

Starmet Corporation

Concord, MA

Aces

The following members have been recognized as Aces for their signing up five new members each.

Maj Robert L. Douthit

Maj Robert D. Marcinhowski

CWO 4 Don M. Muschler

Maj Darryl T. Shamblin

Ms. Sheila I. Visconti

Lt. Col. Scott D. Wagner

Mr. Michael G. Younce

New AAAA Order of St. Michael Recipients

Col. Stephen G. Kee (Silver)

CWO5 George W. Foley (Silver)

Col. Billy R. Wood (Bronze)

Col. David Valcourt (Bronze)

Maj. Thomas F. Schneider (Bronze)

CWO 4 Michael R. Sherman (Bronze)

MSgt. Raymond Lopez (Bronze)

Brig. Gen. Zannie O. Smith (Bronze)

Lt. Col. Dorothea M. Cypher-Erickson (Bronze)

Maj. Steven W. Kihara (Bronze)

Maj. Donald R. West (Bronze)

CWO 4 Donald W. Wright (Bronze)

CWO 4 Richard M. Gotz (Bronze)

SFC Jorge Soriano (Bronze)

Lt. Col. Mark J. McKearn (Bronze)

Lt. Col. William G. Braun III (Bronze)

Col. Cecil B. Hengeveld (Bronze)

CWO 4 Carlton R. Jenkins (Bronze)

Lt. Col. Victor P. Chargualaf (Bronze)

CWO 4 Robert A. Plomski (Bronze)

Lt. Col. Kenneth R. Crook (Bronze)

Merton S. Dubois* (Bronze)

Maryann Trittschuh (Bronze)

Lt. Col. William F. Jernigan, Jr. (Bronze)

Dale L. Hanson (Bronze)

Maj. Gen. Joseph K. Kellogg, Jr. (Bronze)

CWO 5 Robert A. Brooks (Bronze)

CWO Carroll M. Roberts (Bronze)

Lt. Col. Oren L. Hunsaker (Bronze)

Maj. Gary Jones (Bronze)

Maj. Eduardo Gutierrez (Bronze)

Maj. Gregory A. Brockman (Bronze)

Maj. Donald G. Lisenbee, Jr. (Bronze)

Maj. Christopher D. Wright (Bronze)

Lt. Col. Gary M. Servold (Bronze)

Maj. Eugene F. Coyne (Bronze)

Leslie H. Locke (Bronze)

*posthumous

New AAAA Life Members

Mr. Charles W. Aten, II

Mr. David E. Boyken

Col. Daniel E. Fleming, Ret.

CWO 4 David N. Kenolio, Jr., Ret.

Lt. Col. John N. Lawless, Jr.

Capt. Charles R. Seymour III

Lt. Col. Robert M. Williams, Ret.

Maj. John M. Wilson

New AAAA Sustaining Members

Waylon Jones RV Camping Center

In Memoriam

Mr. Merton S. DuBois

CWO 4 Robert E. Howard, Ret.

Col. Robert E. Oberg, Ret.



North Texas Chapter

Webb Joiner, Bell Helicopter Chairman, Honored by AAAA

On June 6, 1998, during a joint AAAA/U.S. Army Association (AUSA) business meeting held at the Texas Star Golf Resort, Mr. Webb Joiner (center), Chairman Bell Helicopter Textron, was presented with the prestigious Honorable Order of St. Michael Silver Award by the North Texas Chapter of AAAA.

The award was presented jointly by Mr. Bob Brady (left), current chapter president and Mr. Leroy Worm (right), past chapter president and 1991 Bronze OSM recipient.

Tennessee Valley Chapter



The AAAA Tennessee Valley Chapter held a combined meeting with the local AHS Chapter on June 19, 1998. The luncheon featured guest speaker Lt. Gen. (Ret.) Bud Forster. There were over 100 in attendance and almost half that number participated in the follow-on golf tournament. The event was a complete success. Since both AAAA and AHS essentially draw on the same basic aviation community in Huntsville, Ala., future joint activities are in the planning stage.

At left Brig. Gen. Joseph L. Bergantz (left), president AAAA Tennessee Valley Chapter, presents token of appreciation to Lt. Gen. Forster (Ret.) for providing luncheon presentation.

Tennessee Valley Chapter

On 26 May 98 Maj. Gen. (Ret.) Carl McNair, AAAA Senior VP presented the AAAA Top U.S. Military Academy Cadet of the Year award to Jason A. Foerter in a ceremony at Eisenhower Hall during graduation week at West Point. Jason is from Florence, NJ and graduated fourth overall in the class of '98.



North Country Chapter has been very busy for the last few months.

During a ceremony held on April 9, 1998 Col. David P. Brostrom (left), chapter president North Country Chapter, presented the Order of St. Michael Bronze Award to Brig. Gen. Zannie Smith, Assistant Division Commander, 10th Mountain Division (Light).



(right) at the same event, Col. Brostrom presents the Order of St. Michael Bronze Award to Col. Ann Dunwoody, 10th Mountain DISCOM Commander, after her change of command.



(Above) On June 30, 1998 — Col. Brostrom (right) presented the Order of St. Michael Bronze Award to Col. William Caldwell (right).



In other North Country news, AAAA member Spec. Casey Green was named 10th Mountain Division Soldier of the Year and is now in competition for the 18th Airborne Corps Soldier of the Year. Upon completion of Anderson Union High School in Anderson, Calif., Spec. Casey Green enlisted in the Army in 1995. He attended Basic training at Fort Jackson, and went on to AIT at Fort Eustis, where he attained the MOS of 67T or crew chief. Through hard work and dedication he graduated AIT at the top of his class, and was awarded the Distinguished Honor Graduate. After completion of AIT, Spec. Green moved to Fort Drum with his initial assignment in Co. D, 2nd Bn., 10th Avn.

Spec. Green transferred to Co. A., 2nd Bn., 10th Avn., where he has been for the past two years. He served as a crew chief onboard the UH-60 Black Hawk and assisted in mission completion during two JRTC rotations. He attended Air Assault School and the Aviation Life Support Equipment Course (ALSE).

Spec. Green is the best enlisted soldier in the 10th Mountain Division, and he possesses the credentials to prove it. Spec. Green won the Soldier of the Month Award within his battalion. He was then named the 10th Avn. Bde. Soldier of the Quarter and Brigade Soldier of the Year. He then moved on to the competition at Fort Drum: the Division Soldier of the Year Board. After one week of intense competition and training against the best soldiers in

the division, Spec. Green came out on top and received the coveted Division Soldier of the Year Award for 1997.

Spec. Green has been awarded two Army Commendation Medals, two Army Achievement Medals, the National Defense Service Ribbon, the NCO Professional Development Ribbon and the Army Service Ribbon. He will attend the Warrant Officer Candidate School this fall, and after successful completion, he initiates rotary flight training at Fort Rucker.

NEW MEMBERS

<p>AIR ASSAULT CHAPTER FORT CAMPBELL, KY SGT Gerard A. Callahan ALOHA CHAPTER HONOLULU, HI CPT James D. Grady ARIZONA CHAPTER MESA, AZ COL Thomas L. Ralph ARMADILLO CHAPTER CONROE, TX Mr. Gregory A. Daniel CSM James J. Schiffman, Jr. AVIATION CENTER CHAP. FORT RUCKER, AL SGT Richard S. Adams WO1 George P. Anglim WO1 James A. Arend 2LT Andrew M. Beyer WO1 Michael T. Bollen WO1 Thomas R. Brautigan 2LT Robert E. Bugner WO1 Brian D. Buol 2LT Donald S. Conner 2LT Dennis A. Cooper 2LT Tiffanie S. Cox 2LT David W. Crocker SPC Timothy C. Crosby WO1 Marshall M. Dillon WO1 David Duran WO1 Dale R. Eggert 2LT Travis M. Habhab SGT Zane B. Hanson CPT Bryan K. Heartsfield WO1 Tracy D. Hogan WO1 Steven H. Husted WO1 Dennis T. Jackson Mr. Waylon Jones WO1 Christopher M. Jordan WO1 Kevin M. Keeler WO1 Kennie R. Kelly WO1 Kristen Y. Kolosick 2LT Jeremy D. Loeb 1LT Robert A. Lombard WO1 Thomas J. Luckenbach 1LT Christopher P. Maniscalco WO1 Virgil G. Martin, Jr. COL Gary N. Matteson 2LT Matthew C. Mattingly WO1 Nicola A. Millilo, Jr. WO1 Kevin D. Mitchell 2LT Ryan I. Moore 2LT Heidi M. Moulton 2LT Meagan Olszowski WO1 Nathan J. Otterwess</p>	<p>2LT Jeff L. Parker WO1 William R. Peters 2LT Jennifer S. Posch 2LT Shannon L. Rae 2LT Stanley K. Redmond Mr. Robert J. Rendzio WO1 Brent Allan Reynolds 2LT Heidi A. Ridenhour 1LT Michael J. Sands 2LT Virginia Beth Sanford 2LT Marc D. Santos 1LT Eric D. Shirley 2LT David R. Stevens Jr. 2LT Joseph L. Swindle WO1 William J. Thomas 2LT Beau W. Tibbitts WO1 Timothy R. Vaught 2LT David M. Weese 2LT Marc A. Werner 2LT Jason L. West 2LT John M. Willey 2LT Kelly L. Wilson PFC Felicia A. Wood WO1 Marla A. Woodson CEDAR RAPIDS CHAPTER CEDAR RAPIDS, IOWA Mr. James Mahan CENTRAL FLORIDA CHAP. ORLANDO, FL Mr. James J. Comfort Mr. Frank Duke Mr. John F. Eils Mr. Samuel N. Knight Mr. Richard J. Magill COL Roger J. Stallings Mr. Matthew J. Thompson CAPT Wm. Mark Yerkes, USN COLONIAL VIRGINIA CHAP. FORT EUSTIS, VA Mr. Charles G. Clements SSG Scott J. Fanning MAJ Raymond Ferrara, Ret. CPT Michael H. O'Neill SSG Paul W. Shutter MAJ Todd Michael Stock SFC William L. Thiel, Jr. Ms. Vonda M. Winkler CONNECTICUT CHAPTER STRATFORD, CT Mr. Thomas M. Sullivan CORPUS CHRISTI CHAP. CORPUS CHRISTI, TX Mr. Arturo Berlanga III Mr. Nick Christian Mr. David B. Garcia</p>	<p>Mr. Steven M. VanVleet FLYING TIGERS CHAPTER FORT KNOX, KY CW4 Larry C. Bugg MAJ Kenneth A. Cerney Ms. Pefina R. Duncan CPT Timothy P. Leroux GREATER ATLANTA CHAP. ATLANTA, GA Mr. John A. Dolan IRON EAGLE CHAPTER HANAU, GERMANY Mr. William D. Smith IRON MIKE CHAPTER FORT BRAGG, NC 2LT Darin A. Beard CW2 Robert M. Jorgensen SSG Gerald H. Lord JIMMY DOOLITTLE CHAP. COLUMBIA, SC SGT Christopher L. Kempson SFC Garrett B. Matthews CW2 Todd S. Overcash 1SG Wayne W. Thompson LEAVENWORTH CHAPTER FORT LEAVENWORTH, KS MAJ Kevin P. Robinson MID-AMERICA CHAPTER FORT RILEY, KS 1SG Wilbert T. Brown CW3 Todd A. Clark 1LT John L. Doeller SSG Kenneth R. Gill SPC Joshua R. Hight SFC(P) George R. Litteral Jr. PFC Brett E. Montgomery SSG Joseph P. Murphy CPT Jay D. Offenberger SSG Thomas H. Truscott MONMOUTH CHAPTER FORT MONMOUTH, NJ Mr. Hassam A. Azzam Mr. Kenneth B. Capolongo Mr. Angel Carrillo Ms. Veronica A.G. Dumas MORNING CALM CHAPTER SEOUL, KOREA MAJ Bruce J. Gorski NILE DELTA CHAPTER CAIRO, EGYPT Mr. William A. Bennet, Jr. SFC Randy G. Moyer NORTH COUNTRY CHAP. FORT DRUM, NY PFC Gerardo Ordaz</p>	<p>SPC Orlando L. Vazquez NORTH TEXAS CHAPTER DALLAS/FORT WORTH Mr. Jim L. Naughton NORTHERN LIGHTS CHAP. FORT WAINWRIGHT/ FAIRBANKS AK Mr. Walter L. Avery OREGON TRAIL CHAPTER SALEM, OREGON CW4 Ted Cook, Ret. SFC Ronald E. Divinie BG Ervin T. Osbourn, Ret. MAJ Marilyn K. Woodward PHANTOM CORPS CHAP. FORT HOOD, TX MG Morris J. Boyd CPT Dawne E. Patterson RAGIN' CAJUN CHAPTER FORT POLK, LA SGT Luis H. Rodriguez RISING SUN CHAPTER CAMP ZAMA, JAPAN Mr. Norio Akiyoshi Men SHOWME CHAPTER JEFFERSON CITY, MO CW2 John Roy Masters MAJ Mark W. McLemore LTC Kenneth B. McNeel CW2 Robert L. Moore, Sr. CW3 Paul E. Wade CPT Kurt A. Williams SINAI CHAPTER SINAI, EGYPT CPT Ronald E. Richards, Jr. SOUTHERN CALIFORNIA CHAP., LOS ANGELES, CA CW2 Glenn A. Moya STONEWALL JACKSON CHAP., SANDSTON, VA SGT Vernon L. Crumpler, III Mr. Judith M. Nashedette TALON CHAPTER ILLESHEIM, GERMANY PFC Jacob E. Aason SPC Ralph Aguirre Jr. LTC George M. Bilafer SSG Lloyd G. Brown CW3 Clay M. Carnes SGT Vashana Chambers 1LT Michael N. Coppa SGT Andrew R. Enos CPL Jason W. Field 2LT Joseph R. Gallaher CPT Tim J. Gregory</p>	<p>SPC John P. Groover SPC Kenneth B. Grover WO1 Robert W. Hagerly CW4 Jon P. Hawkins 1SG James F. Hayes CPT Glen E. Heade PV2 Carlene JeTaimie Herron SGT Daniel M. Higgins CW2 Jody A. Kilburn SGT Annie P. Leaks CW3 Jeffrey A. Marler 1LT William E. Morgan II SSG Herbert L. Osterhout 1SG Stephen G. Punter SSG Jessica D. Roderick-Bert SSG Douglas M. Saunders 1SG Danny G. Thurecht SGT Cornell J. Wallace TENNESSEE VALLEY CHAPTER HUNTSVILLE, AL SPC Chad R. Carmichael SGT Larry E. Hillard WASHINGTON-POTOMAC CHAPTER WASHINGTON, DC CW4 Richard A. Clayton Mr. Stan Diez CW4 Dennis L. Elliott CW4 Alvin L. Goss CW4 James Joseph Muthig CW5 Albert G. Olbeter MG Roger C. Schultz CW4 James W. Tharpe CW4 John C. Watson WESTERN NEW YORK CHAPTER ROCHESTER, NY SGT Matthew J. Koehler MEMBERS WITHOUT CHAPTER AFFILIATION SPC Brice G. Harris Mr. Don T. King Mr. Ulrich Knoell CPT Kevin J. Kulwicki Mr. Dennis J. Lehan 1LT David R. Mattimore COL Carleton H. Prothro, Ret. Mr. Robert Quinn Mr. Kevin R. Raftery Mr. James Spiezo Mr. Mike Staid Mr. John Thomas CPT Pedro A. Torres</p>
--	---	---	---	--

FLIGHTLINES Army Aviation Museum Foundation

FLIGHTLINES is a unique, interactive, computerized archive of the personal histories submitted to the program. These records give the museum visitor a firsthand look at the faces and deeds of aviators and aviation enthusiasts through history. With just a touch of the screen a visitor can call up the photos and in-depth information of friends, relatives, or fellow crew members on the display terminal, or browse through sections of historical or technical interest.

Your **FLIGHTLINES** DONATION ...

- ...preserves your personal career history.
- ...adds to the value and depth of this unique database.
- ...provides a valuable education tool.
- ...allows Museum visitors to better understand the people who have shaped Army Aviation.
- ...supports the continued growth of the U.S. Army Aviation Museum and Foundation.

GIVE A PLACE IN HISTORY

Give a gift enrollment to a friend or loved one, or enter a history as a loving memorial to one who has flown his last mission. Call the Museum Foundation office for information and assistance.
ARMY AVIATION MUSEUM FOUNDATION, INC.
 P.O. Box 620610
 Fort Rucker, AL 36362
 (334) 598-2508



In Memoriam

Merton S. DuBois, 68, of Tinton Falls, N.J., died Thursday, July 9 at Jersey Shore Medical Center, Neptune, N.J.

He joined RCA in 1954, where he worked as an instructor at Fort Monmouth and was a technician on the Tiros II weather satellite project. In 1962, he received a bachelor's degree in electronic engineering from Monmouth University, West Long Branch, and began working in the Army at Fort Monmouth, where he held many positions including technical director for project manager, navigation and communications division director, deputy command manager for CECOM special operations liaison office; and his last position, CECOM command champion for aviation.

He was a Scoutmaster for Boy Scout Troop 190 in Neptune and was active in Monmouth council Boy Scouts of America. He was a member and past chapter president of AAAA Monmouth Chapter and a member of the Old Crows Association.

Surviving are his wife, Valerie Corson DuBois; his former wife, Jean; three sons, Jeffry, Gary and David; a brother, Ronald, a sister, Alma Brittingham.

In Memoriam

Retired Army aviator and longtime AAAA member **CWO 4 Robert E. Howard** died July 17 in Virginia. During his 21 year military career Howard served tours in Vietnam, Korea and Europe, and following his 1975 retirement he went to work for Bell Helicopter International in Iran. There he managed the Iranian Army's Forward Area Support Center for aviation logistics training in Isfahan. Upon his 1979 return to the United States, Howard went to work at Fort Eustis, Va., as an Army civilian employee, retiring in 1994 as the deputy director for combat development at the U.S. Army Aviation Logistics School. Those wishing to honor his memory are asked to make contributions to the American Diabetes Association's Peninsula Chapter (P.O. Box 120016, Newport News, VA 23612-0016) or to the Leukemia Society of America (2101 Executive Drive, Hampton, VA 23566).

ARMY AVIATION ASSOCIATION OF AMERICA

49 RICHMONDVILLE AVENUE
WESTPORT, CT 06880-2000
PHONE: (203) 226-8184
E-MAIL: aaaa@quad-a.org

PRESIDENT

MG John D. Robinson, Ret.

SENIOR VICE PRESIDENT

MG Carl H. McNair, Jr., Ret.

SECRETARY-TREASURER

LTG Merle Freitag, Ret.

EXECUTIVE DIRECTOR

William R. Harris, Jr.

PAST PRESIDENTS

GEN Hamilton H. Howze, Ret.

LTG Harry W. O. Kinnard, Ret.

LTG John M. Wright, Jr., Ret.

LTG Robert R. Williams, Ret.

MG George S. Beatty, Jr., Ret.

COL John W. Marr, Ret.

MG James C. Smith, Ret.

MG George W. Putnam, Jr., Ret.

MG Story C. Stevens

BG James M. Hesson, Ret.

MG Charles F. Drenz, Ret.

MG Ben L. Harrison, Ret.

MG Richard E. Stephenson, Ret.

PAST EXECUTIVE

VICE PRESIDENT

Arthur H. Kesten

REGIONAL PRESIDENT

USAREUR Region-AAAA

COL David F. Sale, Ret.

NATIONAL MEMBERS-AT-

LARGE EMERITUS

Joseph P. Cribbins

COL John J. Stanko, Jr., Ret.

VICE PRESIDENTS

LTG William H. Forster, Ret.

MG Robert S. Frix, Ret.

CW5 Jodie R. Glover

MG Clyde A. Hennies

LTG Jack V. Mackmull, Ret.

William J. May III

Daniel J. Rubery

NATIONAL MEMBERS

AT-LARGE

MG Ronald E. Adams

BG Harry H. Bendorf, Ret.

COL Sylvester C. Berndux, Jr., Ret.

MAJ. James R. Bullinger

CPT Curt S. Cooper

SGM Jeffrey R. Culp

COL Robert E. Godwin

CSM Edward Iannone

CW5 Randolph W. Jones

LTC Beth Garrity Marchman, Ret.

COL Daniel J. McGraw

LTG Ellis D. Parker, Ret.

CW4 Joseph L. Pisano, Ret.

MG John M. Riggs

James P. Schwalbe

SFC Pamela L. Shugart

MG James R. Snider

COL Harry W. Townsend, Ret.

BG Rodney D. Wolfe, Ret.

COL Howard W. Yellen

NATIONAL STANDING COMMITTEE CHAIRMEN*

Aviation Warrant

Officers:

CW5 Randolph W. Jones

By-Laws & Legal:

COL John W. Marr, Ret.

Company Grade Officers:

CPT Curt S. Cooper

Contract Review:

MG Carl H. McNair, Jr., Ret.

Convention:

Mr. William R. Harris

Enlisted:

CSM Edward Iannone

Fiscal:

LTG Merle Freitag, Ret.

Hall of Fame Board

of Trustees:

MG George W. Putnam, Jr., Ret.

Industry Affairs:

Mr. William J. May III

Membership:

MG Carl H. McNair, Jr., Ret.

Nominating:

MG Richard E. Stephenson, Ret.

Reserve Component Affairs:

COL Robert E. Godwin

COL David J. McGraw

Resolutions:

LTG Jack V. Mackmull, Ret.

Strategic Planning:

BG Harry H. Bendorf,

USAF, Ret.

National Appointments/

Archivist:

Mr. Arthur H. Kesten

Museum Liaison:

MG George S. Beatty, Jr., Ret.

Parliamentarian:

COL John W. Marr, Ret.

The Military Coalition (TMC)

Representatives:

COL Sylvester C. Berndux, Jr., Ret.

MG Charles F. Drenz, Ret., Alternate

*Contact the National Office

for P.O.C. information

203-226-8184



Legislative Report

Col. Sylvester C. Berdux, Jr. Retired
 AAAA Representative to The Military Coalition (TMC)

♦ Aviation Career Incentive Pay (ACIP) ("Flight Pay") and Aviation Officer Retention Bonus (ACP).

The House mark in section 614 of National Defense Authorization Act (NDAA) H.R. 3616.PCS redefines aviation service for both the ACIP and ACP sections of Title 37 and includes Warrant Officers in the increased rate change for 14 years of aviation service. The senate version has not included this critical language.

The \$650.00 per month ACIP rate for Commissioned Officers was changed in the NDAA, FY98 (H.R.1119.ENR. SEC.615) to \$840.00, effective in FY99. The corresponding rate was not changed on the Warrant Officer table the Senate published. I believe that this was an inadvertent oversight, as the flight pay rates for Warrant Officers have been the same as Commissioned Officer aviators since 1981. Then, as now, both categories of officers share the responsibilities and hazards of "life in the cockpit". Warrant Officers deserve at least the same compensation as Commissioned Officers.

I don't think we need to worry, S2057 is the Senate version of the bill, and we (AAAA and TMC) discovered that the table wasn't in that one.

The correct table is published in the House version. A number of us, including the AAAA Executive Director and a number of The Military Coalition organizations representatives have met with House and Senate members and staffers on this subject. We have blanketed the Senate Personnel Subcommittee and the Armed Services Committee. The House National Security Committee and its Military Personnel Subcommittee. They all informed us that they are aware of the glitch and the Senate is going to agree to accept the House provision during the joint conference on these bills in mid September.

Please support the House ver-

sion of this important legislation.. The House members and Staff are aware of the Senate's intent.

DCSPER is shepherding this issue through the Conference committee process for the Army. You can get the status from internet (<http://www-perscom.army.mil/wod/acip.htm>).

I would suggest that interested members contact, via letter, fax, phone calls or e-mail, Senators Thurman, Cleland, and Kemthorne, Chairman of the SASC, Ranking Minority Member SASC Personnel Subcommittee, and Chairman SASC Personnel Subcommittee respectively and your local Legislators. The point is that we should all remain vigilant on the issue and assume nothing until it is law!

♦ Medicare Subvention Update

The Department of Defense (DoD) and the Health Care Financing Administration (the agency that oversees Medicare) are finally about to implement Medicare subvention, known as TRICARE Senior Prime. Enrollments started at Madigan Army Medical Center, Fort Lewis, WA on July 15. Health care services for Madigan enrollees will begin September 1. DoD anticipates enrollments will begin August 15 (with service starting October 1) at Brooke Army Medical Center and Wilford Hall Medical Center, San Antonio, TX.

Test programs are expected to start up later this year and early 1999 at the six remaining site locations: Keesler Air Force Base, Biloxi, MS; Fort Sill in Lawton, OK; Sheppard Air Force Base in Wichita Falls, TX; Fort Carson and the Air Force Academy, Colorado Springs, CO; Naval Medical Center San Diego, CA; and Dover Air Force Base, DE.

As a reminder, beneficiaries eligible for enrollment in TRICARE Senior Prime must:

- a. Be eligible for Medicare based on age (i.e. age 65 or older);
- b. Have been enrolled in Medicare Part B and agree to remain

enrolled in it; c. Have been formerly eligible for CHAMPUS; d. Must live within the defined catchment area of the military medical facility offering TRICARE Senior Prime; and e. Have received care from any military hospital/clinic (MTF) as a Medicare-eligible prior to July 1, 1997 or must have become Medicare-eligible after June 30, 1997 (NOTE: some bad rumors have been circulated that eligibility requires the applicant to have been treated previously at the particular facility where the test is being conducted.

This is NOT TRUE; prior treatment can have been at any military medical facility).

TMC and AAAA remains concerned about a serious inequity in the rules affecting beneficiaries already enrolled in Tricare Prime who attain age 65 during the period of a subvention test. Currently, only those Prime enrollees who have a military Primary Care Manager (PCM) at the participating MTF will be offered continuous enrollment in TRICARE Senior Prime when they turn age 65. Prime enrollees who have a civilian PCM will be "bumped" from Tricare Prime at age 65, and can only apply for enrollment in Tricare Senior Prime during a future open enrollment period, if there is one. The odds appear stacked against that, since the limited Tricare Senior Prime capacity at each site will likely be filled up within a month after the test starts. Waiting lists will be maintained for those unable to enroll initially, but flow from those lists is likely to be slow.

TMC and AAAA believes strongly that any TRICARE Prime enrollee who resides in the catchment area should have the option to age into TRICARE Senior, regardless of the military or civilian status of their PCM. We have urged DoD to change this arbitrary and unfair policy.

♦ Medicare Subvention Copayments:

TMC expectations had been that enrollees in Tricare Senior Prime would not have to maintain any Medicare supplemental insurance, since Medicare HMOs have very modest co-payments.

However, a reading of the recently released "fine print" of subvention test rules indicates enrollees in Tricare Senior Prime could, in fact, be liable for substantial co-payments in some situations. Specifically, co-pays for skilled nursing care and durable medical equipment are substantially higher than most civilian Medicare HMOs charge. Military hospitals cannot provide skilled nursing care in house, so Senior Prime enrollees will be sent to a civilian skilled nursing facility. Most Medicare HMOs provide 100 percent coverage of skilled nursing care for the first 100 days, but Tricare Senior Prime enrollees will be charged \$95 per day after the first 20 days. Additionally, Senior Prime enrollees must pay 20 percent of the negotiated fee for durable medical equipment; most other Medicare HMOs provide 100 percent coverage.

TMC and other military associations were unaware of these co-pays and had Not been provided information on them. In late July we were alerted by the Retired Activities Office at Madigan Hospital (the site of the first Medicare subvention test) that Tricare Senior Prime enrollees could be subjected to skilled nursing facility (SNF) co-payments of \$95 per day after the first 20 days.

Subsequently, representatives of The Military Coalition met with Dr. Sue Bailey, D.O., Assistant Secretary of Defense for Health Affairs, on July 31, to appeal that decision and request that the proposed SNF Co-payments for days 21-100 be waived. Dr. Bailey showed her strong inclination to honor commitments and to put People first. In an August 5th letter to The Military Coalition, Dr. Bailey indicated that she had decided to waive the SNF co-pays for the days in question. This is a significant people-oriented initiative and we appreciate Dr. Bailey's decision to have DoD assume the financial risk for SNF care, rather than impose it on military beneficiaries. Medicare's Health Care Financing Administration has approved this change and it will appear as an addendum to the marketing materi-

als that will be distributed at each site.

♦ Homeowner Mortgage Insurance:

The House passed S. 318, a bill that would let homeowners cancel private mortgage insurance coverage imposed by their mortgage company once they have paid off 20 percent of their home's value. Mortgage companies would be required to cancel such payments in most cases after a homeowner reaches 22 percent equity in the home.

Many lenders require this insurance from home buyers who don't make at least a 20 percent down payment on the home. The catch? The insurance protects only the lender in case of default on the loan; it offers no protection at all for the homeowner.

♦ Tricare Contract Protests Upheld.

On July 14, the General Accounting Office (GAO) ruled that DoD must reopen the competitive bidding process for award of the Tricare contract to Anthem Alliance for Health, Inc.'s for Tricare regions 2 and 5. Region 2 encompasses North Carolina and Region 5 covers Michigan, Wisconsin, Illinois, Indiana, Ohio, Kentucky and most of West Virginia (except the northeast corner). A similar ruling seems imminent for Tricare Region 1, Sierra Military Health Service Inc. which covers Northern Virginia, northeastern West Virginia, Pennsylvania, Maryland, the District of Columbia, and all states

north and east.

But both contract awards were protested to GAO by unsuccessful bidders. GAO sustained the protests despite a DoD appeal, finding that DoD failed to adequately disclose to bidders all the details on how their bids would be evaluated.

What does this mean for uniformed service beneficiaries in those regions? It depends on which contractor wins the new bidding process. If the same contractors win the rebids, there should be no impact. If a different contractor is selected for either or both, some beneficiaries in the affected Regions may eventually have to consider switching doctors in the event their doctors don't participate with the new contractor. As a practical matter, nothing will happen for a while. It will take at least 12 months for solicitation, negotiation and award of a new contract, with an additional 7-month transition if a new contractor is picked.

♦ Retirement Review on Agenda for 106th Congress?

In discussing the Defense Appropriations bill on the Senate floor on July 30, Sen. Ted Stevens (R-AL) made some fairly emphatic comments about the insufficiency of the post-1986 retirement system often called REDUX, because of the significant reduction in benefits compared to the systems in effect prior to 1986. Senator Stevens stated that he's going to work with Congress and DoD to "get it fixed". This initiative is high on the legisla-

tive agendas of The Military Coalition and we look forward to working with DoD and Congress to improve the program. The current REDUX multiplier reduction for service members, who serve less than 30 years, and the one percent reduction in Cost of Living Adjustments, are a sure fire prescription for significant retention and readiness problems.

♦ Defense Authorization Conferees Announced

The House and Senate have announced the list of conferees who will negotiate a compromise between the two chambers' respective versions of the FY1999 Defense Authorization Bill. Previously, senior committee leaders had expressed hope they would be able to complete this work by the end of next week. If one or more of your legislators appear on the list, please call, fax or e-mail them on the following issues:

♦ Aviation Career Incentive Pay (ACIP) ("Flight Pay") and Aviation Officer Retention Bonus (ACP)

See lead article for discussion. The message to the Senate conferees is to recede on S2057 to the House in section 614 of National Defense Authorization Act (NDA) H.R. 3616.

FEHBP-65 test: This test would allow Medicare-eligible beneficiaries at selected sites to enroll in the Federal Employees Health Benefits Program. Urge Senate conferees to approve as broad a test at as many sites as possible, including at least

one site where there is a Medicare subvention test. (The Senate would authorize four sites for less than \$50 million per year; the House would authorize 6 to 10 sites at \$100 million per year, including at least one subvention site.) Base closures and nationwide implementation of Tricare Prime mean older retirees are being locked out of the military health care system. Even at subvention sites, only a fraction of the Medicare-eligible population can be served in military facilities. We need the maximum number of test sites to get the most accurate data on participation and cost. We need to test FEHBP-65 at one or more subvention sites to know how the two programs will interact.

♦ Paid-Up Survivor Benefit Plan (SBP):

Urge House conferees to support the Senate proposal to award "paid-up SBP coverage" status to retirees who have attained 70 or more years of age and have paid SBP premiums for 30 years, effective October 1, 2003. This is essential as a matter of equity to these long-contributing retirees, in recognition that the government subsidy for SBP has slipped from the long-promised 40 percent to only 26 percent in 1998, as verified by the Department of Defense Actuary who oversees SBP.

This means retirees have paid higher-than-necessary premiums for decades. The Senate proposal will help redress that situation in a way that will cost the government nothing until 2003.



U.S. Army Aviation Museum Foundation, Inc.

Maj. Gen. Daniel J. Petrosky (left), Commanding General, U.S. Army Aviation Center, recently presented Maj. Gen. Richard D. Kenyon, Ret. (center), with a brass etching of the U.S. Army Aviation Museum. The etching was in recognition of Kenyon's contributions and dedication in serving as the executive committee chairman of the Museum Foundation for the past eight years. Also pictured is current executive committee chairman, Col. David W. Swank, Ret.

Lindbergh Chapter by Paul L. Hendrickson, Chapter President

The Lindbergh Chapter is celebrating its 38th birthday this year. Coincidentally, it will celebrate its "Fantastic 40th" with the new millennium in the year 2000.

In 1960 there were enough members of the Quad A working or residing in St. Louis to warrant a local chapter. So Brig. Gen. William Bunker, commanding general of the Aviation Command in St. Louis requested five "volunteers" to develop the by-laws and charter request for a chapter to be designated the Lindbergh Chapter. These "volunteers" — Ross Hunter of Vertol, Harry Striker of Bell Helicopters, Gene Loveland of Lycoming Turbine Engines and Carl D. Stephenson and Paul L. Hendrickson, both of the Command — met at Hunter's house and cut and pasted the first by-Laws and request for charter letter. These were signed by Brig. Gen. Bunker and mailed to National the next day and approved almost instantly by the national office.

From that rather humble beginning the chapter set out to be a force to be reckoned with in the Association structure. This was especially true during the Vietnam era. With the membership consistently exceeding the thousand mark, Chapter activities were constant and significant. Brig. Gen. Bunker, the first Lindbergh Chapter President, gave great priority to interaction among all Army aviation and industry aviation organizations. His successors, including both high-ranking civilian and military members of the command, likewise emphasized strong interaction among Army Aviation and Industry elements.

During the 60s when the Vietnam action was at its highest, the chapter co-sponsored the Command Advanced Planning Briefing for Industry (APBI), a series of classified briefings that were designed to communicate to the aviation industry what the immediate and forward planning for Army aviation operations and the supporting research, development and engineering programs were aiming to achieve. These briefings were attended by some of the highest placed members of the aviation industry and helped to achieve the Army targets in new and upgraded equipment. When the Army assigned non-aviation commanders to the Command this program was transferred from the Chapter to the ADPA.

However, the Chapter bounced back with the development of a Chapter-sponsored Army Aviation Product Support Symposium, now formally titled the Joseph P. Cribbins Product Support Symposium. These symposia have been on going since the early 70s. The next one will be held at Huntsville, Ala., and will be the 25th in the series. These symposia have been warmly welcomed by industry. They have been and they continue to be a tremendous communication vehicle between Army aviation and its industry counterparts on the needs of Army aviation, especially in the support arena. Of course, the Lindbergh Chapter transferred the PSS responsibility, along with aviation elements from the command in St. Louis to the newly established Aviation and Missile Command (AMCOM) at Redstone Arsenal, Ala.

Along with the transfer of the Joseph P. Cribbins PSS, the Chapter experienced a significant reduction in membership, as members and functions transferred to the Tennessee Valley Chapter in Huntsville. The Lindbergh Chapter has leveled off and appears to be cruising at a current membership of 200 plus.

The Chapter board is faced with developing programs to replace those so popular in the past, such as the Chapter social receptions held in conjunction with the Worldwide Aviation Logistic Conference (WALC) and the Aviation Intensive Management Items (AIMI) conferences, where Army aviation personnel from all corners of the globe met in St. Louis where some of the most significant sessions on aircraft operations and support transpired. These same functions will still be held in Huntsville, I am sure.

The Lindbergh Chapter is currently reviewing replacement programs to continue to be active in the Army aviation family. One of the new initiatives of the Chapter is to make presentations on Army aviation to all the ROTC units in the chapter area (we may even stray a bit out of the chapter "zone"). This effort is headed by Col. Fred Brown (Ret), the current VP for military affairs (Reserve and ROTC), who is coordinating with the Aviation Center in this effort. We want to see if we can't get some of the best and brightest of these potential soldiers to aim at Army aviation as a career. The Chapter board is also following the leadership of Lt. Col. Dave Reichert (Ret), VP for scholarships, in efforts to continue to expand the chapter contributions to the AAAA Scholarship Fund. We saw eight scholarship awards to the members or progeny of members of the chapter in the 1998 selections, and we would surely like to see this remarkable trend continue.

The Chapter Board is made up of persons who have long been members of the Army aviation community, and who have a strong leaning toward maintaining and advancing the chapter programs. In addition to Fred Brown, Dave Reichert and myself, we have Senior Vice President Col. Ken Kellogg (Ret), Secretary A.J. Anderson, Diane Ottolini, VP for civilian affairs, Paul Kerby, VP for sustaining memberships, Georgia Crenshaw, VP for membership. Cal Worth is VP for industrial affairs, Col. Gerald Green (Ret) is VP military affairs, Lt. Col. Cecil Scalf (Ret) is VP for operations, Susan Barnes continues as VP programs and Harold Strickfaden is treasurer. So when and if you're in St. Louis, don't think that Army aviation has departed this venue; a strong core group still is active and concerned with AAAA matters on a daily basis. Just call me at (314) 928-0359 or email me at phendson@aol.com and I'll be pleased to try to help you with any AAAA matter in this area, or refer you to another Board member who is more qualified to help with your particular situation. And if you wish to join this chapter, our unique Lindbergh Chapter membership certificate can be yours in a trice!

ARMY AVIATION BOOK STORE

U.S. ARMY AIRCRAFT SINCE 1947

Since 1947 - An Illustrated Reference
Stephen Harding

U.S. Army Aircraft Since 1947 is the only comprehensive, up-to-date guide to the 124 types of helicopters, fixed-wing aircraft and experimental flying machines used by the U.S. Army since 1947. After a concise yet thorough introductory history of U.S. Army Aviation, the author discusses each aircraft type used by the Army's air arm, which is the largest, most technologically advanced and most combat experienced force of its kind in the world today. Within each chapter the author includes information on aircraft serials, markings, weapon systems, operational history and other technical data. Illustrated with more than 220 color and black and white photographs, *U.S. Army Aircraft Since 1947* is the definitive reference source on its subject and a must-have volume for all military aviation historians and enthusiasts. [Schiffer Publishing Ltd. Size: 8 1/2" x 11", 264 pages, hard cover; ISBN: 9-7643-0190-X]



A CAVALRYMAN'S STORY

Memoirs of a Twentieth Century Army General Hamilton H. Howze

A Cavalryman's Story is the memoir of a professional soldier, born into the lineage of West Point and recognized today as the father of U.S. Army Airmobile tactics and doctrine. With understated charm and humor, GEN Howze writes of his polo-playing years in a 1930s Army that still relied on horses, and then of the sudden, almost remarkable transition to armored divisions, when the U.S. entered WWII. It was in the mid-1950s that GEN Howze emerged as one of a handful of perceptive Army officers who recognized the potential of a sky cavalry. As the first director of Army Aviation GEN Howze promoted the concept to industry, the government, and the public. His vision came to fruition in the 1960s when he presided over the U.S. Army Tactical Mobility Requirements Board, known as the Howze Board, which proved the viability of sky cavalry in combat. *A Cavalryman's Story* provides an authoritative look at the forging of the modern Army and a wry perspective on the perennial absurdities of military life, whether in peace or war. [Smithsonian Institution Press. Size: 6"x9", 316 pages, hard cover; ISBN: 1-56098-664-6].

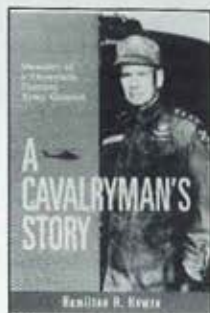

Breaking the

A New Design for
Landpower in
the 21st Century

Douglas A. Macgregor

BREAKING THE PHALANX

Douglas A. Macgregor

This work proposes the reorganization of America's ground forces on the strategic, operational and tactical levels. Central to the proposal is the simple thesis that the U.S. Army must take control of its future by exploiting the emerging revolution in military affairs. The analysis argues that a new Army warfighting organization will not only be more deployable and effective in Joint operations; reorganized information age ground forces will be significantly less expensive to operate, maintain, and modernize than the Army's current Cold War division-based organizations. And while ground forces must be equipped with the newest Institute weapons, new technology will not fulfill its promise of shaping

the battlefield to American advantage if new devices are merely grafted on to old organizations that are not specifically designed to exploit them. [Praeger Publishers. Size: 6"x9 1/8", paperback, 283 pages, ISBN: 0-275-957942]



YEAR OF THE HORSE: VIETNAM

1st Cavalry in the Highland 1965-1967
COL Kenneth D. Mertel (USA, Ret.)

Year of the Horse: Vietnam is the day-to-day story of the Jumping Mustangs - 1st Battalion, Airborne, 8th Cavalry, of the 1st Air Cavalry Division. After describing the activation of this then revolutionary airmobile division at Fort Benning, GA on 1 July 1965, COL Mertel gives a vivid picture of the building of his own Jumping Mustang Battalion, the rigorous training of officers and men, and, finally, the long voyage across the Pacific to Vietnam. Now the test. The answer came quickly and dramatically in a rapid succession of search and destroy operations. COL Mertel pays tribute to the many acts of heroism of his men, who lived, worked and fought together in some of the world's most inhospitable conditions. He also writes movingly of those who never came back. [Schiffer Publishing Ltd. Size: 6"x9", 384 pages, hard cover; 59 color photographs, 9 maps; ISBN: 0-7643-0190-X]

THE NEW YORK TIMES BESTSELLER
IN DRAGON—THE BATTLE THAT
CHANGED THE WAR IN VIETNAM

WE WERE SOLDIERS ONCE... AND YOUNG



LT. GEN. HAROLD G. MOORE (Ret.)
and JOSEPH L. GALLOWAY

WE WERE SOLDIERS ONCE... AND YOUNG

Harold G. Moore and Joseph L. Galloway

We Were Soldiers Once... And Young brings the war back home with unforgettable stories of those who lost family members to combat. This devastating account rises above the specific ordeal it chronicles to present a picture of men facing the ultimate challenge, dealing with it in ways they would have found unimaginable only a few hours earlier. It reveals to us, as rarely before, man's most heroic and horrendous endeavor. [Harper Collins Publishers, Size 5 1/2"x8". 483 pages, paperback. ISBN: 0-06-097576-8]

DANCING ROTORS

Harry E. (Ned) Gilliland, Jr.

Dancing Rotors, is a book about special helicopter usage, documenting the evolution of U.S. military helicopter precision flight demonstration teams from 1948 through 1976. It covers Army and Navy efforts to provide unique shows to stimulate recruiting into both branches of service, and especially into their rotary-wing aviation programs. A wealth of very unique helicopter history, heretofore untold, is now within the reach of every helo enthusiast. [Aerofax, Inc. Size 8 1/2"x11". 483 pages, paperback. ISBN: 0-942548-57-4]

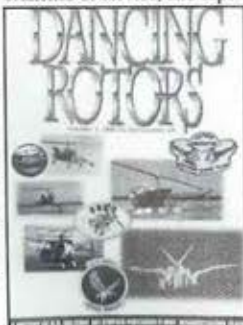

ORDER YOUR BOOKS TODAY!

Name _____

Address _____

City, State & Zip _____

Tele: _____ FAX: _____

I prefer to pay as follows: Check _____ MasterCard _____ VISA _____

Credit Card # _____ Exp. _____ Signature: _____

U.S. ARMY AIRCRAFT - Harding	# _____	\$50.00*	\$ _____
YEAR OF THE HORSE: VIETNAM - Mertel	# _____	\$40.00*	\$ _____
A CAVALRYMAN'S STORY - Howze	# _____	\$29.95*	\$ _____
BREAKING THE PHALANX - Macgregor	# _____	\$29.95*	\$ _____
DANCING ROTORS - Gilliland	# _____	\$29.95*	\$ _____
WE WERE SOLDIERS ONCE... AND YOUNG - Moore and Galloway	# _____	\$20.00*	\$ _____
*(Prices Already Include Shipping & Handling Fee)		TOTAL	\$ _____

Place your order now to receive your free copy of "Army Aviation Cub to Comanche"

Please return this form, with payment to:

Army Aviation Publications, Inc., 49 Richmondville Ave., Westport, CT 06880-2000

Tele: (203) 226-8184 - FAX: (203) 222-9863

Allow 6-8 Weeks For Shipment • *Add 6% Sales Tax If Shipping To Connecticut



**DON'T
MISS
THE
AAAA
CONVENTION!**

**Opryland
Hotel &
Convention
Center
Nashville,
Tennessee**

**MAY 9-12
1999**



FUNCTIONAL AWARD NOMINATIONS

Contact the AAAA National Office for nomination forms for these awards. Membership in AAAA is not a requirement for consideration.

SUSPENSE 1 SEP 98 AAAA AVIONICS AWARD

Sponsored by Cubic Defense Systems, Inc., the AAAA Avionics Award will be presented at the 1998 AEC Symposium to "the person who has made an outstanding contribution to Army Aviation in the area of Avionics during the awards period encompassing 1 August 1997 through 31 July 1998."

AAAA AIRCRAFT SURVIVABILITY EQUIPMENT AWARD

Sponsored by Lockheed Martin, the AAAA Aircraft Survivability Equipment Award will also be presented at the 1998 AEC Symposium. It will be presented "to the person who has made an outstanding individual contribution to Army Aviation in the area of ASE during the awards period encompassing 1 August 1997 through 31 July 1998."

SUSPENSE 15 OCT 98 1998 AAAA AIR/SEA RESCUE AWARD

Sponsored by Lucas Aerospace, the AAAA Air/Sea Rescue National Award will be presented "to the crew or crewmember who has performed a rescue using a personnel rescue hoist that saved the life or eased the suffering of an individual or individuals during the awards period encompassing September 1, 1997 through August 31, 1998."

1998 AAAA TRAINER OF THE YEAR AWARD

Sponsored by Hughes Training, Inc., Link Division, the AAAA Trainer of the Year Award will be presented "to the trainer who has made an outstanding individual contribution to Army Aviation during the awards period encompassing September 1, 1997 through August 31, 1998."

A candidate for this AAAA National Award may be a military or civilian nominee and must be actively involved in Army Aviation Training.

1998 ARMY AVIATION MEDICINE AWARD

Sponsored by Gentex Corporation, this National Award will be presented "to the flight surgeon or aeromedical physician assistant who best exemplifies the contribution to Aviation during the awards period encompassing September 1, 1997 through August 31, 1998."

A candidate for this AAAA National Award must be U.S. Army, Active or Reserve Component, and must be actively involved in Aviation Medicine support to Army Aviation.

1998 ARMY AVIATION FIXED WING UNIT AWARD

Sponsored by FlightSafety International, the Army Aviation Fixed Wing Unit Award will be presented "to the unit or detachment with fixed wing aircraft that has achieved the highest level of excellence in training, safety, logistics, operations and support during the awards period encompassing September 1, 1997 through August 31, 1998."

A candidate for this AAAA National Award must be a U.S. Army, Active or Reserve Component, unit or detachment with fixed wing aircraft that has met the foregoing criteria.

1998 AAAA AIR TRAFFIC CONTROL AWARDS

Sponsored by AAAA, the Air Traffic Control Awards will be presented "to the facility, company manager, maintenance technician, and controller that have achieved the highest level of excellence in training, safety, logistics, operations and support during the awards period encompassing September 1, 1997 through August 31, 1998."

Candidates for this AAAA National Award may be a military or civilian nominee and must be actively involved in Army Aviation Air Traffic Control.

L u c a s A e r o s p a c e

Through its sponsoring of the annual
AAAA Air/Sea Rescue Award,

Lucas Aerospace salutes the men and women
of U.S. Army Aviation Crews around the world who
save the lives of others, often at great personal risk.



Lucas 

VARITY

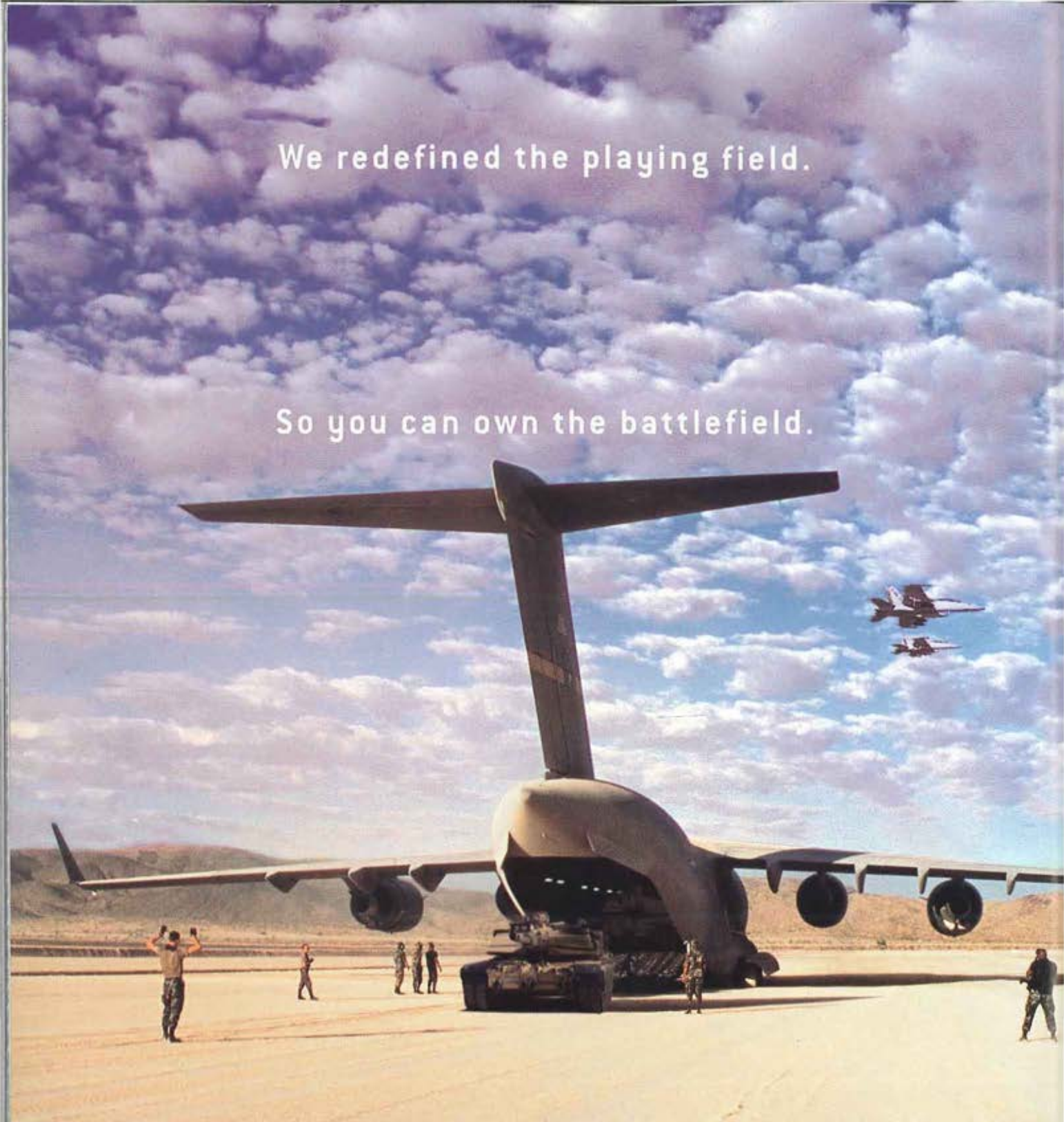
A large military transport aircraft, possibly a C-17 Globemaster III, is the central focus, parked on a tarmac. Its cargo door is open, and a tank is being loaded. Several soldiers are visible around the aircraft. In the background, two fighter jets are flying in a blue sky filled with white clouds. The overall scene is set in a desert-like environment.

We redefined the playing field.

So you can own the battlefield.

WELCOME TO TODAY'S JOINT FORCES WAR ZONE. A hellish place where secure, interoperable voice and data communication make the difference between complete confidence and total confusion. We lead the world in airborne radios and systems, mobile communication systems, fixed-site stations and data modems. Robust systems that operate together seamlessly. Across platforms. Across forces. Across the spectrum of existing global communication systems,

including the 8.33 kHz European standard. High frequency data links for global air traffic management. And a future-proof design for ensured growth. So take control. Release the power of interoperability. Open a line to us today. Because behind battle lines, secure communication is your lifeline. Call 319.295.5100.

www.collins.rockwell.com/government-systems

**Rockwell
Collins**