

Special  
Focus:  
The  
"Warfighters"

SPECIAL FOCUS:  
THE "WARFIGHTERS"

# ARMY AVIATION

OFFICIAL PUBLICATION OF THE ARMY AVIATION ASSOCIATION OF AMERICA • DECEMBER 31, 1997

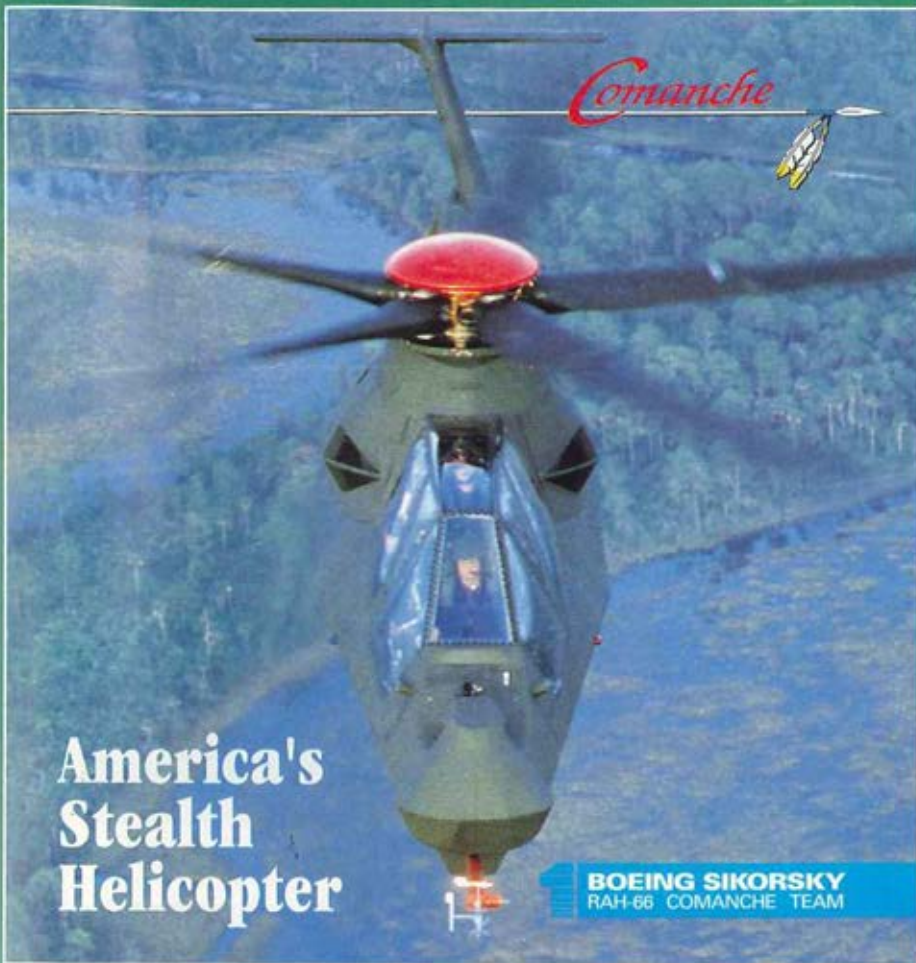

America's  
Stealth  
Helicopter

**BOEING SIKORSKY**  
RAH-66 COMANCHE TEAM

**FEATURE ARTICLES**

- 6 Branch Update: xxxxxx Maj. Gen. Daniel J. Petrosky  
 30 Minimize the Risk of Spatial Disorientation  
 Lt. Col. Malcolm Braithwaite,  
 Col. Simon Durnford and Capt. Robert M. Wildzunas

**WARFIGHTERS**

- 10 The Combined Aviation  
 Force Capt. Christopher W. Mead  
 14 A Case for the Movement  
 to Contact Col. James Simmons  
 17 The Aviation-Air Defense TOC in the  
 10th Mountain Division 1st. Lt. William H. Patrowicz Jr.  
 21 The Warfighter Brigade –  
 A Status Report Capt. Patrick Terhune  
 24 Making the Most of Fire Support Capt. Geoffrey J. Jeram

**WARRANT OFFICER DIRECTORY**

- 37 The Warrant Officers Directory

**DEPARTMENTS**

- |                             |                             |
|-----------------------------|-----------------------------|
| 63 AAAA Calendar            | 56 Army Aviation Book Store |
| 60 AAAA New Members         | 54 Arrivals and Departures  |
| 61 AAAA News                | 4 Briefings                 |
| 55 AAAA President's Message | 59 Marketplace              |

**FRONT COVER**

**Paid Advertisement: The RAH-66 Comanche** Helicopter on a recent test flight over the Everglades. Caption provided by advertiser.

# VOICE AND DATA RECORDER • VADR™

SMITHS INDUSTRIES TOTAL SYSTEM SOLUTION



Smiths Industries systems increase the capabilities of pilots and their equipment. They improve the management of information in the air and on the ground, providing a tactical and competitive advantage. Smiths Industries is a development partner committed to innovation, investment and lifetime support – for commercial and defense priorities worldwide.

Please call for the Smiths Industries Aerospace Guide.  
(USA): (616) 241 8643; (UK): (44-181) 457 8203.

*Flexible configurations of voice and data recording offered by the Smiths Industries Voice and Data Recorder bring modern recorder technology to platforms previously limited by the weight and bulk of traditional recording systems.*

*The compact, lightweight, and affordable VADR™ is available in a variety of configurations.*



**SMITHS INDUSTRIES**  
Aerospace

CIVIL & DEFENSE AVIONICS • ENGINE & FUEL SYSTEMS • NAVAL & MARINE • PRODUCT SUPPORT

**PUBLISHER**  
Lynn Coakley

**EDITOR-IN-CHIEF**  
William R. Harris, Jr.

**EDITOR**  
Stephen Harding

**PRODUCTION MANAGER**  
Barbara Ross

**CIRCULATION MANAGER**  
Mary Ann Stirling

**CIRCULATION ASSISTANTS**  
Debbie Coley, Deb Simons,  
Mary Ellen Kother

**ADVERTISING**

**Peter M. Stern**  
Tel: (203) 532-0335;  
FAX: (203) 532-0131  
**Robert C. Lachowski**  
Tel: (203) 226-8184;  
FAX: (203) 222-9863

Display and classified advertising rates are listed in SRDS Business Publications, Classification 90.

ARMY AVIATION is the official journal of the Army Aviation Association of America (AAAA). The views expressed in this publication are those of the individual authors, not the Department of Defense or its elements. The content does not necessarily reflect the official U.S. Army position nor the position of the AAAA or the staff of Army Aviation Publications, Inc., (AAPI). Title reg ® in U.S. Patent Office. Registration Number 1,533,053.

**SUBSCRIPTION DATA**

ARMY AVIATION (ISSN 0004-248X) is published monthly, except April and September by AAPI, 49 Richmondville Avenue, Westport, CT 06880-2000. Tel: (203) 226-8184, FAX: (203) 222-9863, E-Mail: aaaa@quad-a.org. Subscription rates for non-AAAA members: \$25, one year; \$48, two years; add \$10 per year for foreign addresses other than military APOs. Single copy price: \$3.00.

**POSTMASTER**

Periodicals postage paid at Westport, CT and other offices. Send address changes to AAPI, 49 Richmondville Ave., Westport, CT 06880-2000.

## Briefings

The reigning AAAA Army Aviator of the Year Capt. Donald J. Lee, 1-4 Aviation Regiment, Ft. Hood, Texas, was killed 4 Dec 1997 along with his backseater, CW2 Phil Bowers when their AH-64 Apache crashed near San Saba, Texas at the Ft. Hood Western Training Area.

The **Utah National Guard** has conducted demonstration test flights of **Magellan Technology Inc.'s SkyHook** cargo management system. The system is intended to allow helicopters to deliver or pick up three to six payloads at different locations in a single sortie, reducing the aircraft's time in the air while maximizing its load-carrying capabilities. The SkyHook is aerodynamically designed for stable flight, and provides flight crew with detailed real-time information on the status of the load being carried. The first production units are to be built by **AEL-Tracor**, and are scheduled to ship before the end of the year.

**GTE** has selected Ottawa-based **Magardi Inc.** to design an integrated network-management and communications system for the Army's **White Sands Missile Range, N.M.** to improve safety and efficiency while significantly reducing operating costs.

The veterans of **Office of Strategic Services Detachment 101** are soliciting financial support for their construction of a School of Agriculture, Forestry and Vocations in Lashio, Burma. The facility will serve the descendents of the Kachin peoples who supported Det. 101's highly successful World War II guerrilla war against Japanese forces occupying Burma. The current Burmese government has donated 21 acres for the school, which will house 123 faculty and staff and 540 students. Checks made out to "101 School" should be sent to Roger Hilsman, 251 Hamburg Cove, Lyme, CT 06371, (860) 434-9912.



▼  
**THERE'S A  
WAY TO  
MAKE ALL  
KIOWA  
WARRIORS  
FIERCE.**

▲  
The S/SEP upgrade will give the OH-58D superior situational awareness and hang time, as well as allow it to talk digitally to the "joint world."

Thanks to the Systems Safety Enhancement Program, over 300 fielded OH-58Ds can be as fierce as current production Warriors. This retrofit, including digital avionics and communications upgrades, advanced navigational aids, a 19 percent power boost and improved crash protection, makes this aircraft an even more lethal weapon. As the OH-58D's builder and participant in its evolution, we long ago recognized its potential. And no one's more qualified than us to make sure it lives up to it.

▼  
Write P.O. Box 482, Fort Worth, TX 76101; fax 817-280-2330; or visit our Web site at [www.bellhelicopter.textron.com](http://www.bellhelicopter.textron.com)

**Bell Helicopter** **TEXTRON**

A Subsidiary of Textron Inc.

## Transition to the Future

As our branch moves one year closer to the next millennium, it is a good time to look forward to where Army aviation will be going early in the next century. As we continue to focus our work on Army XXI and look forward even further, it should be apparent that Army aviation will remain a decisive player in our nation's defense.

Our 21st century mission is to maintain our second-to-none warfighting capability as we evolve into Army XXI. There will be new equipment to integrate; new tactics, techniques and procedures (TTPs) to learn and train our units to employ; and quite possibly new ways for our leaders to assess situations and make crucial decisions. We will meet these challenges head-on, embrace the concepts and continually improve our warfighting skills during the transition.

In 1998 we will learn some of the major milestone decisions as to what our Army will look like and how it will fight well into the 21st century. We expect to learn what the Army XXI division structure will be. TRADOC is evaluating three different designs for the Force XXI heavy division. The testing and analysis are complete and we will learn which of the designs (conservative heavy division, strike

### *Supporting the field force is our main attack!*

division or brigadist division) has been adopted, or if a variant of these will be combined to form the chosen design.

Along with supporting our current force, these insights will form the basis

of our combat development effort for the rest of this century and the first part of the next. We have task-organized the Aviation Combat Team to take advantage of our strengths [Figure 1]. As you can see, it is a powerful team. No one element of it alone can take us into the future. Everyone on the team is important as we work the process of Force XXI.

We have crossed the LD/LC and our current force - the Army of Excellence (AOE) - must clearly focus on providing the forces necessary to ensure that national strategy goals and objectives can be met. This is a product-improved version of the Army that totally dominated Iraq's army in Operation Desert Storm and has performed admirably in Haiti, Africa and Bosnia in both stability operations and support operations. The current force must remain trained and focused on our many commitments around the world, while portions of the force simultaneously move toward Army XXI.

Supporting the field force is our main attack! We here at Fort Rucker will lead this attack with Col. R. Lee Gore and CSM John

**MISSION:** It's as certain as gravity: the more complex your air fleet, the greater the headache of supporting it. So perhaps some streamlining is in order. A single source for any service, on any aircraft, anywhere. A single point of accountability, as utterly dependable as the laws of aerodynamics.

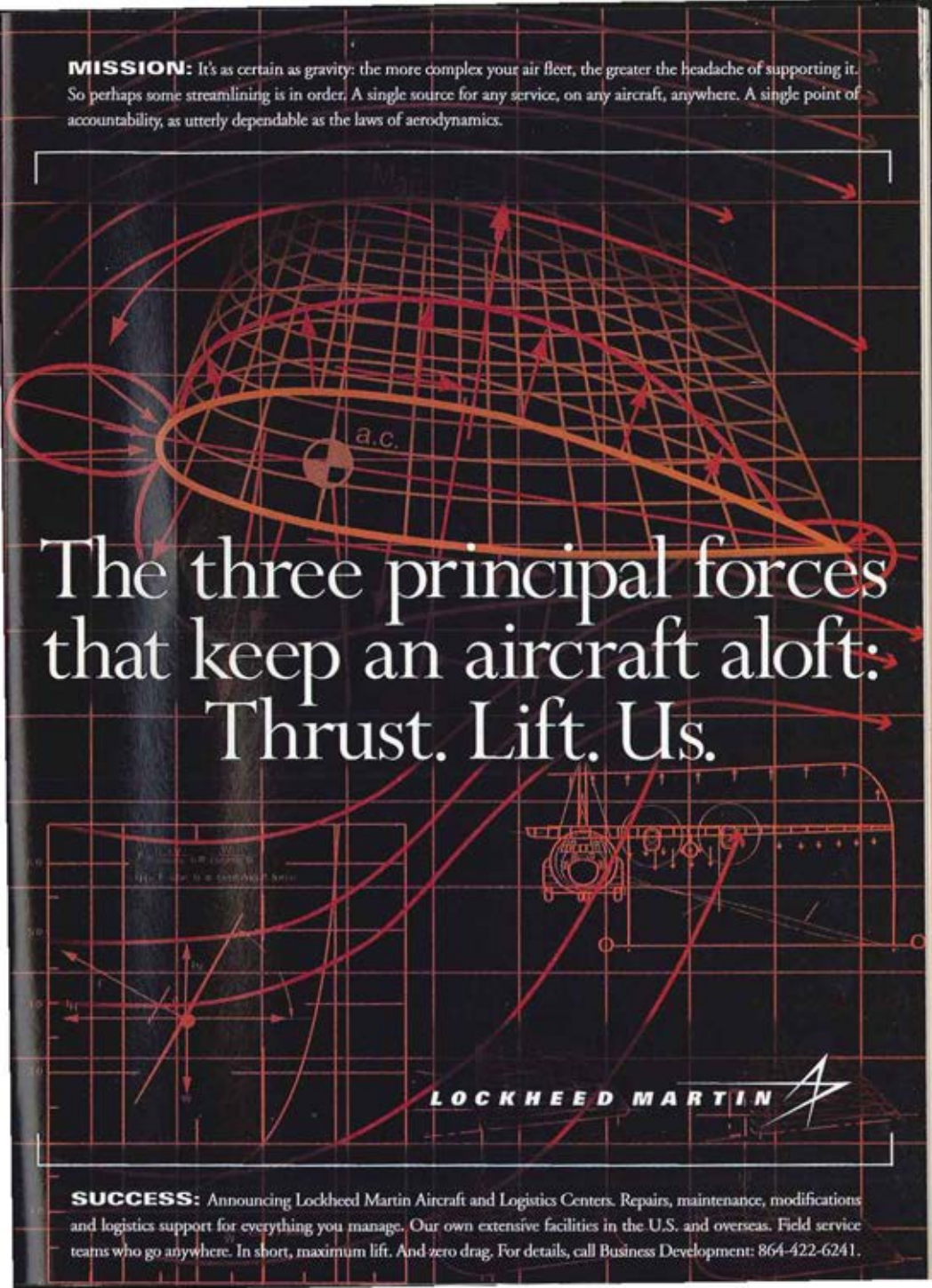

# The three principal forces that keep an aircraft aloft: Thrust. Lift. Us.

LOCKHEED MARTIN



**SUCCESS:** Announcing Lockheed Martin Aircraft and Logistics Centers. Repairs, maintenance, modifications and logistics support for everything you manage. Our own extensive facilities in the U.S. and overseas. Field service teams who go anywhere. In short, maximum lift. And zero drag. For details, call Business Development: 864-422-6241.

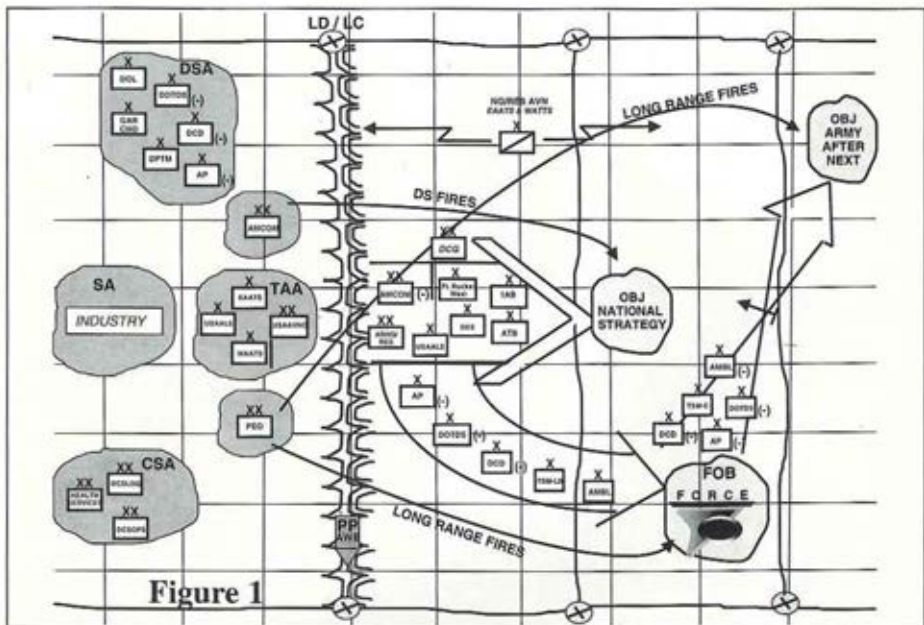

Figure 1

Lawrence of the Aviation Training Brigade alongside Col. Neal Sealock and CSM Sanford Tanna of the 1st Avn. Bde. Both brigades will fight abreast to continue providing the world-class instruction soldiers must have to continue to win this fight. They will be closely supported in this fight by Col. Bob Hoppes and SGM John Weber at the Aviation Logistics School, Maj. Gen. Emmitt Gibson at AMCOM, Maj. Gen. Jim Snider (PEO Aviation), and such reserve component training centers as EATTS and WATTS.

As we continue fielding the AH-64 Longbow and digitizing our current force, we will transition to the Force XXI division design. The TRADOC System Manager-Longbow (TSM-L), Col. Cash Striplin; combat developers led by Col. Mark Danielson; and our team at "Fort Rucker West" in Mesa, Ariz., led by Maj. Patrick Garman and Capt. Bill Gaylor,

will conduct a supporting attack toward our objective of Army XXI. We will continue to develop and refine the tactics, techniques and procedures that our wargaming and National Training Center experience tells us will exploit our ability to conduct decisive operations anywhere in the world. The task at hand is to develop the capability to share that situational awareness with the commander over standard command-and-control displays.

Finally, as Comanche is fielded we will add awesome maneuverability and lethality to Army XXI. This is clearly a deep attack to achieve "leap ahead" technological advantages for the 2010 to 2025 time frame. Our end state is to provide the Army of 2025 with the ability to dominate any military situation, from an urban fight to high-intensity combat. We will use physical speed, agility and lethality to  
*Transition to the Future cont'd. on pg 53*



# 2.5 MILLION

## Our Safety Record is No Accident to reach the

milestone of two and a half million flying hours in nine years without a maintenance-related accident. It's an achievement we're proud of and a reputation we plan to live up to.



WINNER OF THE 1996 AAAA MATERIEL READINESS AWARD  
FOR OUTSTANDING MAINTENANCE SUPPORT



11-TIME WINNER OF AAAA MATERIEL  
READINESS AWARD — *AN INDUSTRY RECORD!*

**DynCorp**

2000 Edmund Halley Drive  
Reston, VA 20191-3436  
703.264.0330

## THE COMBINED AVIATION FORCE

Imagine you are the commander in chief (CINC) of the Combined Forces Command (CFC), Republic of Korea (ROK). You are tasked with commanding and employing the forces of two nations of different cultures, religions and languages to deter and, if necessary, defeat aggression by North Korea. The enemy is less than 70 kilometers from your garrison headquarters and is poised to attack at a moment's notice.

This scenario poses several challenges. One of the most daunting is how to effectively and efficiently provide the ground-component command — comprised of both ROK and American forces — with theater-level attack aviation and general aviation support. Fortunately, the answer already exists: the Combined Aviation Force (CAF).

During crisis periods or hostilities the CAF joins the aviation forces of the ROK Army Aviation Command and the U.S. Army's 17th Aviation Brigade to form a

*The CAF can  
provide support  
across the entire  
spectrum of Army  
Aviation operations*

combined organization that provides the CINC CFC with attack, medium lift and lift capabilities. This combined aviation package provides the ground commander with the fire power and maneuverability to successfully deter or defeat North Korean aggression.

The CAF currently consists of the ROK's 31st Attack Group and 61st Assault Group, and the 17th Avn. Bde. By pooling these ROK and U.S. forces, CAF planners can tailor virtually any type of aviation package to support U.S. forces, any of the three ROK armies or the ROK Capital Defense Corps. This well developed aviation package provides the ground commander with virtually unlimited combat multipliers to influence the critical junctures in the fight.

The CAF is tasked with, and is capable of providing, support across the entire spectrum of Army aviation operations. This includes attack and reconnaissance, air assault and air movement, aerial resupply



## Now you can own the night wherever you are.

Owning the night gives you the war-fighting edge essential to victory. That's why we're working to expand your night vision capabilities.

For the first time, fixed-wing aviators can trust the night to ITT. U.S. Air National Guard, Air Force and Navy as well as military pilots worldwide can benefit from our improved Aviator's Night Vision Imaging System (ANVIS).

And for ground forces, our GEN III 25mm image intensifier is available as a direct retrofit to upgrade existing weapon sights and drivers' viewers.

This dedication to advancements, combined with our proven performance, has earned us 100% of the U.S. Army's OMNIBUS IV procurement. A full-service organization, ITT is committed to continuous improvement, supporting night operations of U.S. and allied military forces around the globe.

Air or ground, anywhere in the world, you can depend on the proven performance of ITT night vision. ITT. *The best in the world at what we do.*

**ITT** Defense & Electronics

# CAF ORGANIZATION

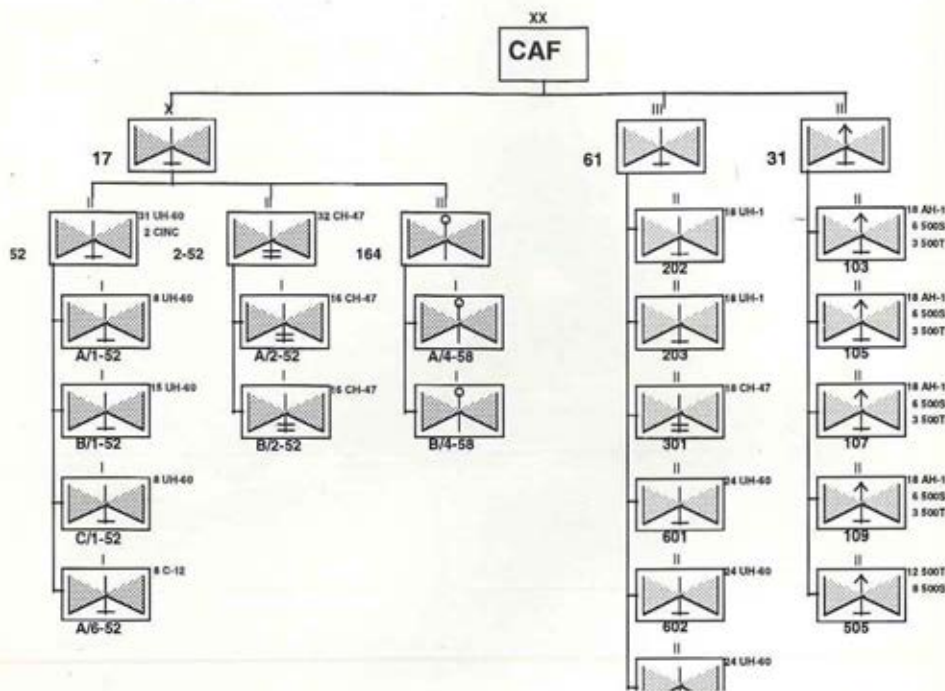

and such mission-specific operations as mass casualty evacuation, combat search and rescue, quick reaction force support and combined unconventional warfare operations.

The CAF is staffed to accomplish these diverse missions in a combined fight. The CAF is commanded by an ROK Army major general, with the 17th Avn. Bde. commander serving as deputy CAF commander. Each command section, primary staff section and speciality section (A2C2, LNOs and weather) is staffed by both ROK and American personnel in order to estab-

lish a cohesive team. Korean Augmentees to the U.S. Army (KATUSAs) play a major role in day-to-day CAF operations. KATUSAs translate critical information to ensure the concept of the operation and the commander's intent are clearly articulated to, and understood by, all parties. The KATUSAs also bolster cultural and social relations between Koreans and Americans by increasing awareness of the other's customs and practices.

The CAF uses two annual theater-level exercises as its major training vehicles and as conduits for ensuring maximum effec-

tiveness and ability in conducting combined operations.

The first exercise is Ulchi Focus Lens (UFL), a theater-wide computer simulation exercise using the Corps Battle Simulation (CBS) system. During UFL the CAF receives, plans and conducts (via computer simulation) the full range of missions it would receive and conduct during a crisis or hostilities. The CAF's ROK and American planners together use the Military Decision Making Process (MDMP) to conduct mission analyses and to develop courses of action to ensure mission success.

The CAF's second annual theater-level exercise, Foal Eagle, is a series of smaller independent exercises that culminate in a corps force-on-force field training exercise (FTX). The CAF provides simultaneous support to the majority of the exercises conducted during this period.

During UFL-97 the CAF was extremely successful in breaking the "stove pipe" mission support paradigm, in which missions received from the Ground Component Command (GCC) in support of ROK forces were flown only by ROK aircrews, and support for U.S. forces was flown only by U.S. aircrews. By eliminating the "stove pipe" paradigm the CAF has been able to better support the GCC by individually tailoring each support package to maximize the combat effectiveness provided to the ground forces.

Counter-penetration operations offer an excellent example of how the CAF can tailor aviation packages to support the ground commander. To support a counter-penetration operation, the ROK and U.S. C3 plans officers first conduct a combined mission analysis. The CAF then maximizes the use of all assets to provide the ground commander with devastating combat power to  
**Combined Aviation Force cont'd. pg. 20**

*Attention: Junior Military Officers*

**If you're leaving the military with brand-new goals — let us show you how to reach them.**

If you are a *proven leader* and are seeking greater challenges, then a career as a *Merrill Lynch Financial Consultant* may be for you. In fact, you can bring to the position the best product you have. *Yourself*. Your abilities, experience, talents, and leadership experience.

A career as a *Merrill Lynch Financial Consultant* offers many benefits, including:

- high income potential;
- affiliation with a leading organization; and
- flexibility to work in virtually any location you choose.

Let us show you a superb way to reach your goals.

If you are interested in becoming a *Merrill Lynch Financial Consultant* or would like more information on our upcoming career days, mail or fax your resume to:

Joseph N. Hébert, III, VP  
Merrill Lynch • P.O. Box 9000  
Princeton, NJ 08543-9000

Phone: 1-800-759-BULL  
Fax: 609-282-1777

DATES: Saturdays,  
Jan. 10th, or April 18th, 1998

PLACE: Merrill Lynch  
Conference Center  
Plainsboro, NJ

*Women and minorities are encouraged to apply.*

*Merrill Lynch is an Equal Employment Opportunity Employer.*

**The difference is Merrill Lynch.**



**Merrill Lynch**

A tradition of trust.

© 1996 Merrill Lynch, Pierce, Fenner & Smith Incorporated.  
Member SIPC.

## A CASE FOR THE MOVEMENT TO CONTACT

Personal observations made over the past several years at the National Training Center and as a squadron and brigade commander have convinced me there is a need to conduct movements to contact with attack helicopter battalions — especially during deep operations. While much improvement has been made in the “decide, detect, deliver” process, there remains a significant problem in getting the most current intelligence picture to the battalion commander as he is en route to the engagement area. I offer here a technique of potential value to the attack battalion commander, one that will help him to inflict maximum damage on the enemy while minimizing losses.

Significant technology increases in the intelligence community — systems such as JSTARS, All Source Analysis System (ASAS) and ADOCCS — give planners a much better ability to track enemy formations and to project when they will arrive in an area that favors our ability to engage and destroy them. Often, our battalions have to fly for up to an hour en route to the engagement area prior to the attack. During this time the enemy situation can significantly change. Our doctrine states that if the enemy situation is unclear a movement to contact is an appropriate

*Attack helicopters  
can help find  
and fix a highly  
mobile enemy.*

form of maneuver to gain contact with the enemy and then conduct a hasty attack to destroy the force.

The movement to contact begins with the Intelligence Preparation of the

Battlefield (IPB). This is a commander-driven process. A technique that is used in the 6th Cavalry requires commanders to answer five questions:

1. Where is the enemy currently located?
2. Where is he going? (What is his objective? What route/routes will he use?)
3. Where can I best kill him?
4. When will he be there?
5. What does he have that can hurt me?

With this information the commander and his staff determine the key terrain within the area in which the fight is likely to occur. They then begin to develop the scheme of maneuver and scheme of fires to support the fight.

The brigade staff concentrates on how to fight from the Release Point (RP) through the Engagement Area (EA) while the Deep Operations Coordination Cell at the brigade's higher headquarters coordinates the operation necessary to fly the route to the release point. The enemy will usually have options that include multiple routes through the EA. The friendly commander develops maneuver



# KEEP THE APACHE ON THE WARPATH LONGER.

**Additional mission flexibility, enhanced combat capability, improved safety and lower O & S costs for the Apache.**

The HM-025 *GUARDIAN*® *APACHE* Auxiliary Fuel System provides approximately 130 gallons for the AH-64D and the AH-64A. The system mounts in the ammunition bay and is interchangeable with the ammunition storage magazine. Only minor aircraft modifications are required. After installation of fixed hardware, the auxiliary fuel tank can be installed or removed in less than 30 minutes. Fuel is carried in a MIL-T-27422B crashworthy, self-sealing bladder which is simultaneously pressure refueled with the main tanks. The HM-025 *GUARDIAN*® *APACHE* gives commanders the flexibility of extending training flights or of carrying more munitions on the wing pylons for deep penetration missions.

For more information on providing mission flexibility for your Apache, call (602) 967-5185, fax (602) 968-3019, e-mail robertsonaviation@worldnet.att.net or write P.O. Box 968, Tempe, AZ 85280.

**ROBERTSON**  
AVIATION

Range Extension Fuel Systems

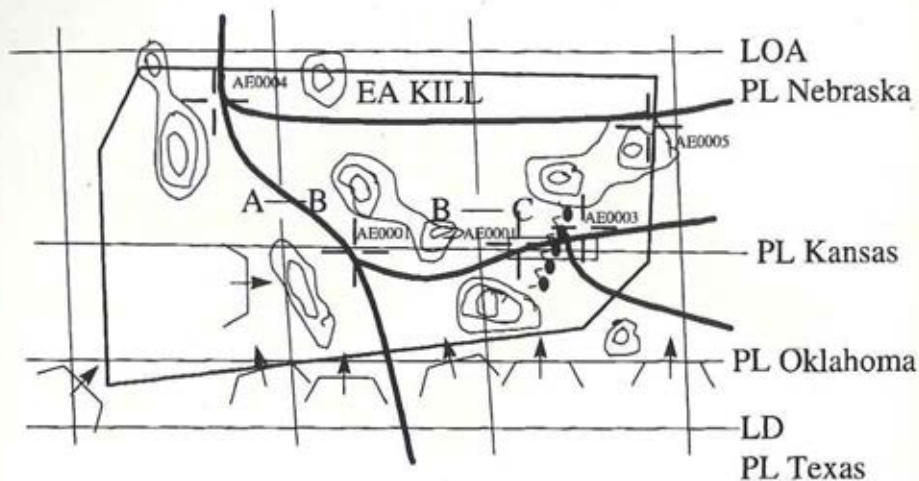

Figure 1

graphics that include a Line of Departure (LD), Phase Lines (PLs) and Boundaries. He deploys his battalion with companies focused on the primary routes through the engagement area and controls the advance to contact by using the PLs and boundaries. As the companies move forward by bounds, they clear likely enemy Air Defense Artillery (ADA) positions and observation points by fire. Once a company gains contact, the battalion commander evaluates the information and then decides to maneuver those companies not in contact to the flanks of the enemy force and continues the attack on the enemy formation. If the engagement is within supporting artillery range fires are placed on the enemy while the commander maneuvers his additional forces.

The battalion commander passes his assessment to the brigade commander, who makes the decision to commit additional forces to complete the destruction, directs a re-attack or begins preparation for the unit's next mission.

There are several advantages to this form of maneuver:

1. Friendly forces gain contact with a small force.
2. Friendly forces take advantage of the maneuver advantage of the attack helicopter over ground forces.
3. One battalion can cover multiple routes, maintaining the ability to mass on the target.
4. The helicopters remain stationary for relatively short periods of time, thus reducing exposure to enemy weapons systems.

Does it work? My observations at NTC and here in Korea indicate that it does. While it does take some training and changing mind sets to be effective, it is an option that commanders should consider as they develop their TTPs.

\*\*

*Col. James E. Simmons is commander of the 6th Cavalry Brigade, Korea.*



## THE AVIATION-AIR DEFENSE TOC IN THE 10TH MOUNTAIN DIVISION

Over the past year the 10th Mountain Division's 10th Aviation Brigade and 3rd Battalion, 62nd Air Defense Artillery (3-62 ADA), enhanced each other's operations by connecting their respective tactical operations centers (TOCs). This merger created a command post known as the Aviation-Air Defense TOC (AVADTOC). These efforts have met with considerable success as they integrated combined-arms operations in time, space, purpose and resources.

This merger of command posts began, however, under less ambitious pretenses. Both units originally discussed how the ADA's early-warning capability could improve the aviation brigade's operations. What started as simple interoperability training developed into much more. Here are the highlights.

In October 1996 3-62 ADA augmented the brigade's TOC with a Forward Area Air Defense Command, Control and Intelligence (FAAD C2I) shelter and a Brigade Air Defense Coordinator (BDE ADCOORD) during the division's Battle Command Training Program. As a result, the brigade received an air picture that improved its operations planning and battle tracking. Meanwhile, 3-62 ADA received friendly flight information that enhanced its ability to man-

*Merging aviation and ADA TOCs can enhance the capabilities of each.*

age fire-control measures.

In February 1997 the brigade sought this air picture as it flew real-world counterdrug support missions along 140 miles of the United States-Mexico

border. The FAAD C2I shelter received data from AWACS aircraft and the Western Air Defense Sector (WADS) headquarters at McChord Air Force Base, Wash. Consequently, the FAAD C2I shelter saw an air picture along the entire area of operations and dramatically improved the brigade's airspace management. After reviewing these exercises, both elements judged that these improvements reduced the possibility of fratricide and increased the brigade's battlefield situational awareness. The AVADTOC thus became a more plausible and attractive idea to pursue.

In June 1997 Maj. Gen. Lawson W. Magruder III, commander of the 10th Mtn. Div., approved the AVADTOC's testing during field training exercises. He said the division would probably enhance its Army Airspace Command and Control (A2C2) if both command posts merged. Additionally, he believed that the complementary capabilities of both units would significantly improve battlefield visualization and force protection.

In July 1997 the two organizations commenced AVADTOC operations during



**Figure 1**

## AVAD TOC PROGRESS TOWARDS FORCE XXI

Purpose:

- Exploitation of Technology
- Increased Battlespace Visualization
- Increased Situational Awareness
- Improved A<sup>2</sup>C<sup>2</sup>, Targeting and EW
- Enhanced Force Protection
- Additional Commo Nets

Endstate:

- Increased Command and Control
- Integration of Combined Arms With More Efficient Use of Time, Space, Purpose, and Resources



**Figure 2**

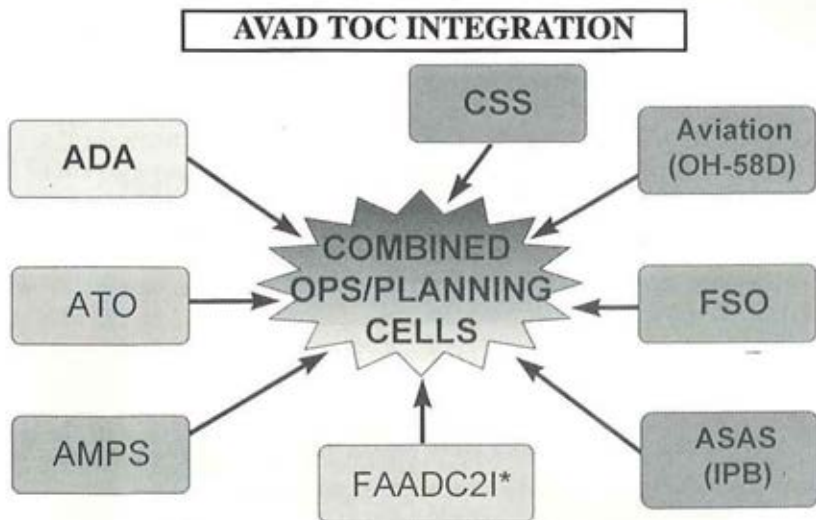

**Figure 3**

\* LSDIS Radar  
AWACS  
PATRIOT Radar

Operation Falcon Peak '97. Besides improvements in A2C2, the units demonstrated the ability to conduct horizontal planning for air defense protection of aviation assets. Furthermore, the units' headquarters commanders discussed force-protection measures including perimeter security and an augmented quick-reaction force, and also discussed combat service support operations. The combined crew-served weapon capability increased to two MK-19s, six .50-caliber machine guns and four M-249s.

In September 1997 the two organizations continued to substantiate the AVADTOC concept during a division-level field training exercise. The units incorporated lessons learned from previous exercises and improved the command post design and unit force-protection procedures. Additionally, both units proved that they could execute a merged jump TOC. Upon inspection of the AVADTOC Lt. Gen. John M. Keane, commander of XVIII Airborne Corps, optimistically viewed the

innovative effort.

The merger's focal point is battlespace visualization. The improved situational awareness enhances the rapid response to contingency missions and fire-support requests; the management of pre-planned missions; and the application of crisis management. Furthermore, the timely manipulation of positive and procedural control measures maximizes early engagement of hostile aircraft and drastically reduces the possibility of fratricide. These measures change frequently but in the past were disseminated slowly throughout the battlefield. The AVADTOC's dissemination of these measures occurs swiftly and accurately, and it addresses potentially dangerous situations between aviation and air defense units much earlier in the course of battle.

Tertiary benefits of the AVADTOC include the benefit of collective intelligence preparations of the battlefield, course of action development and wargaming. The redundancy in intelligence gathering and operations battle-

tracking also provides a more accurate picture of the division's battlespace.

While analyzing the pros and cons of such a merger, some believe that it creates an area that is too large and is compromising to threat target-acquisition capabilities, special operations forces and artillery efforts. However, note that the AVADTOC is no larger than other maneuver brigade command posts across the division. Additionally, both the 10th Avn. Bde. and the 3-62 ADA discovered that the AVADTOC does not save man hours and thus warrant a reduction in manpower. They believe that it is essential for each organization to retain the flexibility to operate separately if needed.

Finally, the remaining question is why aviation and air defense command posts would merge when forces are continually fighting in larger battlespaces. The answer is twofold: First, it represents an economy of force. Second, and most importantly, the exploitation of technology warrants an increased emphasis on command and control.

The AVADTOC improves the forces' ability to maximize combat power over greater distances and the integrated staff enhances the aviation brigade's ability to function as a maneuver brigade headquarters. Experimentation with appropriate command-and-control-designs for the AVADTOC continues with each new exercise. The AVADTOC is a concept worth further investigation, and the 10th Mtn. Div. believes that it is representative of force utilization changes that are necessary as we progress toward Force XXI, the Army Vision 2010 and the Army After Next.

\* \*

*1st Lt. William H. Patrowicz Jr. is the 10th Avn. Bde. air defense coordinator for the 10th Mtn. Div.*

## Combined Force cont'd. from pg. 13

prevent the enemy's penetration of friendly lines.

The CAF employs ROK and U.S. CH-47 Chinooks and ROK and U.S. UH-60 Black Hawks to insert necessary FARP equipment and security assets to support the counter-penetration operation. Armed escort is provided by ROK MD-500 helicopters armed with miniguns and 2.75 inch FFARs. The MD-500s are also used as aerial scouts to get eyes on the engagement area, pass targeting information and conduct the battle hand-over to ROK AH-1 Cobras waiting in nearby holding areas. The synchronization of this complex operation is controlled by the combined aviation task force commander in a U.S. UH-60 C2 Black Hawk. Contingency plans for downed-aircraft recovery, search and rescue, and mass casualty evacuation are all supported and conducted by CAF assets.

Although these annual exercises provide excellent opportunities to conduct combined aviation operations, the CAF's leaders have realized that to achieve a truly inter-operable combined effort the CAF must augment these exercises with consistent, realistic and repetitive combined training. Well planned social events are also held to encourage stronger and closer bonds between the staffs of different cultural backgrounds.

Regardless of what the future holds for South Korea, one thing is certain. With the enemy watching closely through the sights of his weapons across the barren demilitarized zone, the Korean peninsula holds many dangerous and volatile possible futures. Whatever the contingency, the CAF will serve as the combined force of choice, acting as a deterrent to hostilities and, if needed, as a viable and lethal combat force.

\* \*

*Capt. Christopher W. Mead is the S3 (Plans) 7th Avn. Bde, Korea.*

## THE WARFIGHTER BRIGADE — A STATUS REPORT

When asked what the 18th Aviation Brigade can bring to the battlefield, Col. Michael C. Flowers, the unit's commander, had no problem providing a viable answer.

The "Warfighter" brigade, Flowers said, brings more to the battlefield

than any other aviation brigade in XVIII Airborne Corps. The brigade provides the corps commander with attack, reconnaissance, assault and heavy-lift capabilities, as well as with command-and-control platforms, air traffic services and fixed-wing assets. This "Total Army" brigade can handle a multitude of missions, and its wartime posture is unique within XVIII Abn. Corps. The 18th Avn. Bde.'s self-sustaining structure allows it to complete any aviation mission which arises in today's Army.

The 18th Avn. Bde. fields an impressive array of aviation assets, providing the XVIII Abn. Corps commander with the ability to:

- conduct simultaneous deep attacks throughout the battlespace;
- conduct defensive operations on a non-linear battlefield;
- conduct reconnaissance in depth across

*The 18th Avn. Bde. brings more to the battlefield than any other aviation brigade in XVIII Abn. Corps.*

the corps front;

- shape the battlefield; sustain the force;
- allow for rapid maneuverability to achieve mass; and
- conduct joint and combined-arms operations.

As a corps brigade, the 18th Avn. Bde.'s unique wartime organization

and early deployment posture allow the XVIII Abn. Corps commander the versatility to use aviation as a force package to quickly respond to any contingency operation. The Warfighter brigade gives the corps commander the ability to respond with a range of flexible deterrence options and decisive combat operations through the allocation of key aviation assets in order to:

- quickly weight the main effort;
- strategically sea-, air- or self-deploy an aviation task force for early force projection and early force protection;
- conduct Joint Air Attack Team (JAAT), Suppression of Enemy Air Defense (SEAD), air assault and air combat; and
- provide air traffic services and airspace integration at corps and division level.

**Attack Helicopter Capabilities.** The Warfighter brigade's three AH-64 attack

## BRIGADE ORGANIZATION

- Active Component  
 Reserve Component

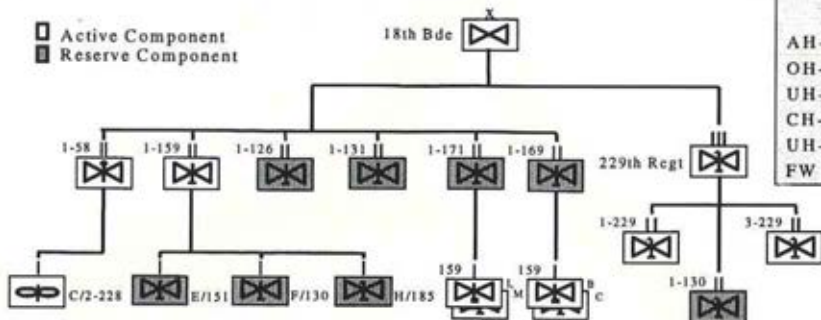

### TOTAL

AH-64	48
OH-58D	15
UH-60	78
CH-47	64
UH-1	32
FW	8

## BUILDING COMBAT POWER



51 X CH-47D W/INT TANKS  
 3 X UH-60A C<sup>2</sup> W/ESS

186 KM  
 EACH WAY



**ALL COMBAT  
 POWER ON THE  
 GROUND IN  
 30 MINUTES**

### BRIGADE TASK FORCE

TWO BATTALIONS(+) LIGHT INFANTRY  
 TWO BATTALIONS 105MM ARTILLERY  
 SUPPORT EQUIPMENT:

3 X AVENGER

3 X SEE

972 INFANTRY SOLDIERS  
 100 ARTILLERY SOLDIERS  
 50 SUPPORT PERSONNEL

## BUILDING COMBAT POWER



18

51 X CH-47D  
65 X UH-60  
3 X UH-60A C<sup>2</sup>

112 KM  
EACH WAY



ALL COMBAT  
POWER ON THE  
GROUND IN  
30 MINUTES

### BRIGADE TASK FORCE

TWO BATTALIONS(+) LIGHT INFANTRY  
TWO BATTALIONS 105MM ARTILLERY  
SUPPORT EQUIPMENT:  
3 X AVENGER  
3 X SEE  
2,120 INFANTRY SOLDIERS  
100 ARTILLERY SOLDIERS  
50 SUPPORT PERSONNEL

helicopter battalions have the capability to build combat power faster than any other XVIII Abn. Corps brigade. These attack assets give the corps commander the ability to shape the battlefield by simultaneously conducting corps deep operations, force projection, force protection and economy of force.

#### Assault and Heavy-Lift Capabilities.

The 18th Avn. Bde.'s ability to build combat power faster than any other XVIII Abn. Corps brigade is based on its UH-60s and CH-47s. These assault and heavy-lift assets give the corps commander an air-assault capability for decisive combat operations, and enhance command and control. The graphics above and left give examples of possible brigade operations:

**Air Traffic Service Capabilities.** Air traffic services round out the Warfighter brigade's unique capabilities. Collocated

with each division in XVIII Abn. Corps, ATS companies provide tactical and terminal ATS capabilities and airspace integration. Additionally, the corps (GS) ATS company provides the same capabilities to meet corps requirements without having to draw on divisional assets.

In summary, what the 18th Avn. Bde. brings to the battlefield is a unique and powerful capability no other XVIII Abn. Corps aviation brigade can provide. The Warfighter brigade is a combat powerhouse that gives the XVIII Abn. Corps commander the flexibility to influence the battlefield today, and into the 21st century.

\*\*

*Capt. Terhune is secretary for the general staff of the 18th Avn Bde., Fort Bragg, N.C.*

## MAKING THE MOST OF FIRE SUPPORT

Cavalry organizations use the same fire-support systems, procedures and control measures as the rest of the Army. However, cavalry units regularly employ artillery in combined-arms operations at lower levels and in a larger battlespace.

The fire-support system includes many elements: observers, such as scouts and Combat Observation/Lasing Team (COLT) teams; planners, such as the Fire Support Team (FIST) and Fire Support Element (FSE); and the guns, whether mortars, artillery or CAS assets. The largest cavalry unit, the armored cavalry regiment, includes a fire-support element similar to any maneuver brigade. It has no organic artillery at the regimental level, but may have an attached or direct supporting (DS) battalion. The regimental fire-support coordinator, whether the staff's fire-support officer (FSO) and fire-support element (FSE) or the DS battalion commander, has the formidable task of integrating the commander's fires across an area of operation (AO) that may extend across an entire corps.

A regimental cavalry squadron, unlike a maneuver battalion, has an organic artillery

*Helicopter firepower can be a maneuver element or fire-support asset, as needed.*

battery. This combined-arms organization enables such squadrons to employ their indirect fires across the wide frontages and areas characteristic of security and economy-of-force missions. Indeed, massed regimental fires would not be able to range across the regimental

AO. The squadron is usually the highest cavalry echelon where 155mm howitzers can range most of its AO.

In the ground cavalry troop an organic mortar section provides the most timely fires and the fire-support team (FIST) helps the commander coordinate and control fire-support for the troop.

The regimental aviation squadron (RAS) has no organic fire-support, but relies on the assets of the other squadrons, both artillery and mortar, and often has priority of fires of direct-support artillery until the enemy's main effort is found. The regimental commander and divisional squadron commander may employ helicopter firepower as a maneuver element or as a fire-support asset, depending on the situation.

Simply put, cavalry organizations have a fire-support system similar to a brigade or task force with direct support or attached



artillery. So the cavalry deals with similar planning and coordinating challenges but applies them over wide areas where freedom to maneuver is essential.

**Challenges of Planning and Executing Fires.** Fire-support lessons learned at the combat training centers often address fire-support. Observers apply those lessons to the types of units that rotate through the National Training Center (NTC) and the Joint Readiness Training Center (JRTC), which are usually not cavalry units. Recently, however, the 2nd and 3rd Armored Cavalry Regiments did train at the NTC. This discussion applies some past fire-support lessons to cavalry organizations and includes some comments about these recent cavalry rotations.

Planning fire-support is the FSO's responsibility. His is a formidable task in any organization and very difficult indeed during fluid and fast-paced cavalry missions. The FSO directs the activity of the fire-support element and synchronizes the activities of the other fire-support agencies. At the regimental level, he may have no organic artillery, but must integrate fires from the corps, close air support (CAS) aircraft, naval gunfire (NGF) and DS artillery into the commander's plan with flexibility and speed. If he succeeds, the subordinate squadrons can maximize the effectiveness of their fire-support with the same concept of fires. The FSO succeeds by translating the commander's concept and scheme for fires into the fire-support plan and coordinating its execution among various fire-sup-

port assets and subordinate fire-support elements.

Because the cavalry collects intelligence for its own benefit and for its supported units, the S-2 plays a key role in planning operations and fire-support. The FSO and S2 define the high payoff targets (HPTs) across a corps-level AO. Together, they target enemy elements to develop the situation according to the commander's concept. In this, the purposes for fires for the cavalry usually differ from those of a ground brigade, aviation brigade or attack battalion. Fires may be used (or not used) to portray

*"Maneuver must employ overwhelming combat power to destroy or defeat the enemy on the battlefield. The fire-support system provides a large portion of this combat power through employment of firepower from various assets" — FM 17-95, Cavalry Operations.*

strength or weakness in an avenue of approach, to force the enemy to divulge his intent (of advancing or holding terrain), or in various ways (such as masking fires and suppression of enemy air defenses, or SEAD) to retain the freedom to maneuver.

Due to the rapid planning and execution cycles of modern combat, the regiment, squadron and troop often plan in parallel. Consequently, early and close vertical coordination in the fire-support channels is critical for a unified plan. Successful fire-support plans for an ACR may take two general schemes, depending on the ACR's mission.

When an ACR holds terrain or attacks in a confined sector, such as for an NTC rotation, it fights its fires as would a brigade or division. The fire-support plan involves massing the squadron artillery batteries at regimental level under the DS artillery battalion or brigade as the 2nd ACR did during its NTC rotation in December, 1996.

In this task organization, early, top-down planning is especially critical and the regimental commander's concept for fires must be adopted by subordinate FSOs. When refining the plan, the squadron FSO submits targets and control measures, nesting his plan within the regiment's plan. The squadron commander then articulates its importance to his squadron's scheme of maneuver. The FSO and S2 determine decision points for employing the artillery. The S3 develops the maneuver plan and tasks subordinate elements to cover these observation needs using both air and ground cavalry for redundancy. The regiment may also use its own observation teams — such as an attached COLT team — or create a regimental attack team (RAT) "out of hide," as the 2nd ACR did. The regiment can insert deep observers with the RAS assault troop.

This task organization has the advantages of better army airspace coordination and control at regimental level and greater power when massing fires. It also has disadvantages, including the challenge of synchronizing fires, which I will discuss later.

Note that just as an ACR may cover a division (or brigade) sector, so too might a divisional squadron cover one or two battalion-sized sectors. With DS artillery, the squadron can plan and employ fires like a task force or like a brigade in microcosm. With the Multipurpose Light Helicopter (MPLH) kits, an air cavalry troop may also insert a forward team to observe deep deci-

sion points or named areas of interest (NAIs).

When an ACR maneuvers in a security or economy-of-force operation across a corps front or flank, the squadrons retain their organic batteries. Decentralized control of artillery ensures fire-support in squadrons that may be widely separated. The regimental fire-support concept will be less directive and allow flexibility for squadron fire-support planning. The regimental S3 and FSO will effectively package such higher fire-support assets as CAS, DS artillery and perhaps an air attack helicopter company for squadron execution. This task organization takes advantage of the cavalry's ability to synchronize the combined-arms team.

Synchronizing the combined-arms team is one of the cavalry's better abilities. Its combined-arms organization enables it to operate at great distances from the supported or parent unit. The organization provides the needed combat power at the lowest level. Fire-support system response time varies directly with the number of echelons between the observer and the guns. With artillery at the squadron level, the system omits the regiment, brigade and division echelons and responds quickly to calls for fire.

Clearance of fires remains an obstacle to responsive fires even with squadron artillery. Intelligent planning and effective coordination help the squadron staff hurdle this obstacle to synchronize fires. The FSO uses coordinated fire lines (CFL), no-fire areas (NFA) and other control measures to coordinate and clear fires in the squadron AO. Effective use of fire-support control measures on a linear front means placing CFLs as close to the FLOT as possible, with NFAs around deeper elements (such as COLT, LRS, aviation OPs and BPs) to enable the fire-support system to quickly respond in the forward edge of the

battle area.

The cavalry often operates in a nonlinear battlespace, but flexible use of fire-control measures can still facilitate clearance and improve responsiveness. For area security missions, the squadron CFL may circle the objective. For route security missions, raids and reconnaissance-in-force missions, the unit might consider using a CFL on either side of the route or avenue of approach. Planning NFAs over forward friendly locations greatly facilitates calls for fire through the depth of a guard or cover. Also, because cavalry operations so closely integrate Army aviation down to squadron and sometimes troop level, a fire-support coordination line (FSCL) proves more appropriate than a CFL, even when established by a squadron.

**Fire-support for the Regimental Aviation Squadron (and visa versa).**

The regimental aviation squadron has vast potential to make the most of artillery and close air support, but must work through special challenges. Unlike the ground squadrons, an RAS has no organic artillery battery. The regimental commander may employ the squadron in many different ways and FSOs must integrate fire-support into the maneuver plan early at the regimental level.

This is especially true when the commander has the RAS screen beyond the ground squadrons and across the breadth of the regimental AO. The FSO must develop the fire-support simultaneous with and integrated into the regimental scheme of maneuver. Specifically, the FSO must address how the

regimental fires support the RAS with DS artillery, if any, and how the ground squadrons' organic artillery will support the RAS. This planning and coordination will affect the positioning of the guns, so squadron staffs need the regiment's concept and scheme of fires to plan both fires and maneuver. The FSO has the challenge of articulating how subordinate unit artillery assets will serve the higher unit's overall mission.

Modern RAS organizations have the OH-58D(I) Kiowa Warrior, whose missions demand fire-support more than ever. The aircraft carries a relatively small armament

*"The communication capabilities of the warrior provide the means to rapidly coordinate and employ multiple rocket fires, CAS and attack helicopters without achieving overkill or wasting assets." — FM 1-114, "Regimental Aviation Squadron."*

payload and the aircrews save their organic weapons for suppression and hasty and precision attacks, but the more persuasive reason for fire-support is the aircraft's design. Originally intended as a dedicated artillery observation and CAS direction platform, it retains an outstanding ability to observe fires, designate targets and communicate digitally on the fire-support net.

Unfortunately, after-action review comments at NTC and JRTC describe the relatively few calls for fire made by the aircrews. To blame the aircrews, though, does not address the problem. The aircrews use what

they know will work; when artillery fire responds slowly and unpredictably the aircrews simply won't use it. Effective fire-support planning for the RAS must address this problem, which includes challenges in clearing fires, system interoperability and fire-support system proficiency.

Ground squadrons, which train regularly with their organic battery and mortar sections, work through these problems before fighting. The RAS commander, with no organic fire-support assets, cannot easily incorporate them into his squadron training plans, but must fight for fire-support training and resources. Hands-on equipment training and testing is critical to achieving the great potential for effective fire-support. Without such training, the squadron FSE will not have the experience to select the appropriate equipment settings to enable interoperability between the OH-58D(I) and the various FSE elements, he will not gain proficiency with clearing fires and positioning guns across the regimental AO, and the aircrew's skills with indirect fire "switchology" and voice calls will atrophy.

Training solves many of these problems before the fight, but the FSO can also address them with thorough planning and rehearsals. Planning artillery for the RAS includes several considerations beyond the planning for the ground squadrons:

- Can the artillery support the RAS through the depth and breadth of its AO?
- Are position areas for the guns, whether squadron batteries or DS artillery, separated from air routes?
- Is the fire-support plan thoroughly briefed and packaged in a usable form (e.g., as TOC map overlays and as Air Mission Planning System fire-support overlays)? Fire-support overlays for the AMPS will greatly reduce the planning time for the

RAS staff and air cavalry troops.

- Are Family of Scatterable Mines (FASCAM) fires planned with the regimental engineer to supplement, reseed and back-up air volcano mine fields?

- Will the RAS use the regimental digital fire-support net, its own voice or digital net, or a ground squadron fire-support net? The answer will depend on the situation, command relationship and mission. It will have considerable impact on fires responsiveness across the regimental/squadron sector, clearance of fires and communication.

- Do the ground squadrons understand their roles for fires, both artillery and mortars, for supporting the RAS?

- Is SEAD planned for all air missions; assault, attack and cavalry?

SEAD is commonly planned for attack and assault missions, but many planners overlook it for cavalry or consider it too difficult to apply to a long duration air screen or zone reconnaissance. But with the S2, the FSO can find areas where on-call SEAD will protect the aircraft and enable them to extend their coverage. Particularly in mountainous areas, such as the NTC, parallel ridges provide great observation and combat positions, but the valleys between provide the enemy air defenders favorable alleys to acquire and attack the air cavalry. The FSO can plan lethal and non-lethal SEAD to allow the aircraft to safely transition across those valleys and similar danger areas.

SEAD may also include smoke and illumination. Depending on the enemy acquisition and weapon systems and degree of protection, masking and obscuring smoke on suspected ADA positions may prove more effective than explosives. As our enemies acquire night-vision systems, illumination rounds at night will effectively degrade earlier generation night-vision devices, but will



# SOLVENT FREE CLEANING WITH BETTER ENGINEERING

ISO-9001  
Certified



Better Engineering's jet washers have successfully replaced PD-680 and solvent sinks at Military Bases across the country and around the world. These automatic detergent and water systems have been approved for cleaning **GUN SYSTEMS, TURBINE ENGINES & COMPONENTS, WHEELS, GSE PARTS, ETC.**

See Your Environmental Mgr. For P-2 Funding

**Better Engineering Mfg., Inc.**

NSN's Available GSA Contract #GSO7F-5778A

## FREE DEMO

# 1-800-229-3380

not shut down the ANVIS goggles currently used by the U.S. Army.

**Organic Artillery for the Divisional Squadron.** The ground squadrons in an ACR have their own artillery for the many reasons already discussed. Those same reasons provide good arguments for providing divisional squadrons with their own artillery batteries.

The divisional cavalry squadron may operate screen and guard missions in front of the division and along its flanks. Its area of operation is generally restricted by the range of divisional artillery or its operations, requiring fire-support, may restrict the supporting divisional guns. When the division prepares for an attack and uses the cavalry to deceive along and guard a flank, the divisional guns will be moving or oriented to the divisional front, not to the squadron at the flank.

A force design change to provide a divi-

sional squadron its own battery would empower the squadron to more effectively train and integrate combined-arms operations and would free the divisional artillery for the main effort.

With its own battery, employing conventional and Copperhead fires, the squadron could develop its own engagement areas and use its weapon systems to attack or defend, perform economy-of-force missions and better replicate a much larger force. With the squadron's advantages of effective low-level synchronization and Kiowa Warrior observation and direction, the artillery would indeed be put to good use.

\*\*

*Capt. Geoffrey J. Jeram, an OH-58D pilot, is attending the Combined Arms Service Staff School before taking up an assignment in Korea.*

## MINIMIZE THE RISK OF SPATIAL DISORIENTATION

**A**viators — do you agree that information from conventional flight instruments is sometimes, if not always, difficult to interpret and integrate? Who among us hasn't suffered a breakdown in scan during instrument flight and then had difficulty getting back to it?

Commanders — wouldn't you like your aviators to be relieved of some of the workload in maintaining or regaining spatial orientation, and thus control of the aircraft, so that they can better turn their attention to the tactical task?

These cognitive situations are made worse when a pilot suffers spatial disorientation (SD). As we know, the standard countermeasure for recognized SD has always been to "get onto instruments and make them read right." But in the panic and stress frequently associated with such events, it is often difficult to mentally integrate the

*A new flight  
instrument display  
may help reduce  
SD-caused  
accidents.*

information from five flight instruments to regain correct control.

SD is a major source of attrition, particularly in military helicopter flying. Recent reports from the U.S. Army Aeromedical Research Laboratory (USAARL) at Fort Rucker, Ala.; estimate that as much as 30 percent

of Class A through C Army helicopter accidents involve SD.

Many of these accidents would occur regardless of the instrument display in use, since the aviators are simply not looking at the instruments. However, there are a number of accidents which involve the classically disorienting conditions of inadvertent entry to instrument meteorological conditions, whiteout or brownout, which might be amenable to improved instrument displays. These particular accidents represent 25 percent of Army rotary-wing SD accidents. In addition, there are those accidents

in which a more easily understood instrument display might prevent the circumstances leading to disaster by providing an improved source of information against which aircrews might check their progress.

Two British exchange flight surgeons working with staff at USAARL have developed and tested a novel flight instrument display they believe achieves the goals mentioned above. This has been accomplished by moving away from the traditional type of display in which a pilot is continually gathering information to form a mental "picture" of the aircraft's attitude and its flight path. The USAARL novel display allows the pilot to specify particular parameters such as airspeed, altitude and heading, and then match his control inputs to a simple integrated display so that the parameters are easily maintained or regained.

The original aim of the display was to

provide an easy source of information for recovery following an episode of disorientation, but the display also provides adequate information for standard instrument flight. The pilot can check a flight parameter at any time, but is freed from the requirement to continually sample them to maintain stable flight. In essence, maintaining orientation using the novel display replaces a high-level cognitive task with a comparatively low-level tracking task.

This article briefly describes the display, which has a U.S. patent, and some of the convincing results from a flight simulator assessment.

In its current developmental format, the display (figure 1 below) is created by a laptop computer, driven by processed and integrated electrical signals from the flight instruments, and projected onto a flat-panel visual display unit. The central field of the

display consists of a series of squares and a small triangle. The triangle moves across the squares depending on aircraft speed and heading. Movement of the triangle along the x and y axes is a derivative of the "orientation" functions of pitch and roll, since airspeed depends on pitch inputs and heading on roll inputs. Fore and aft cyclic movements are used to maintain the desired aircraft speed by steering the triangle to the mid-

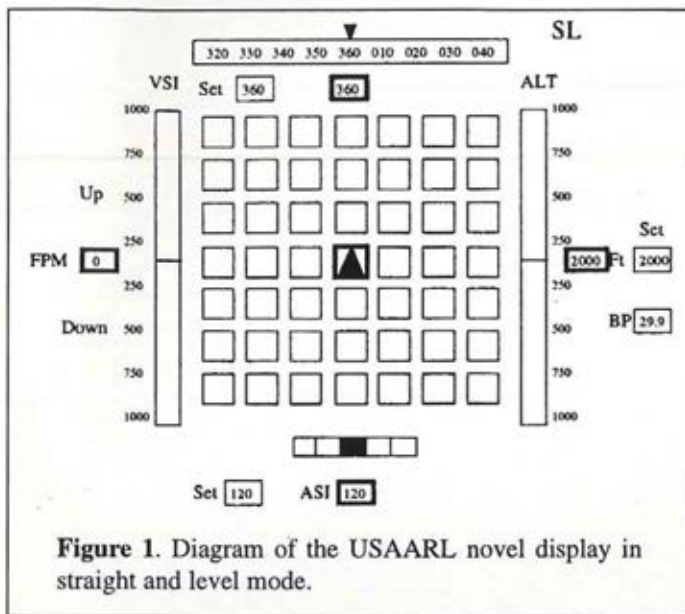
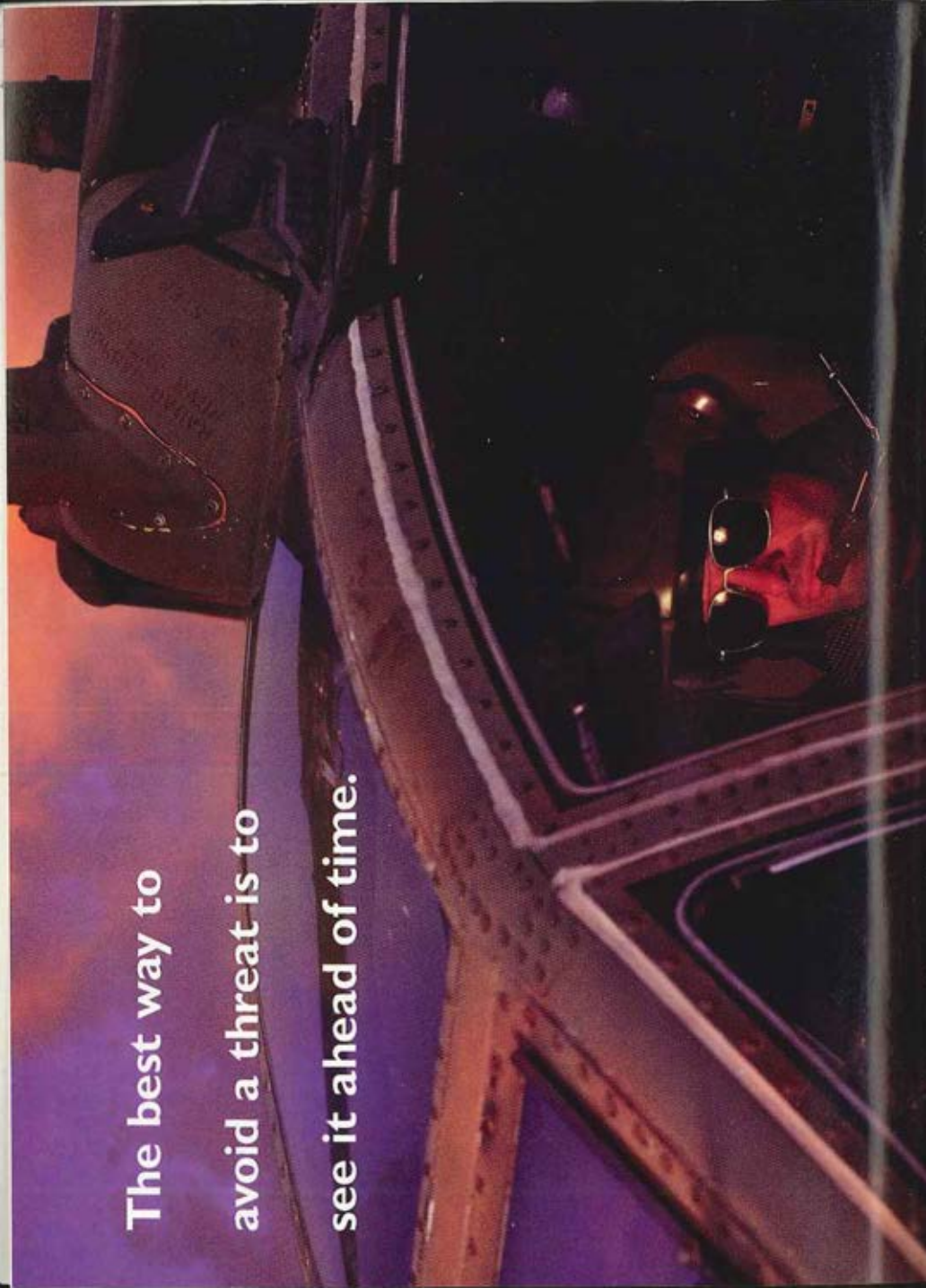



Figure 1. Diagram of the USAARL novel display in straight and level mode.

The best way to  
avoid a threat is to  
see it ahead of time.







**AN/ALQ-211**  
**Suite of Integrated RF**  
**Countermeasures (SIRFC).**

With the ALQ-211 Suite of Integrated RF Countermeasures, you're ready for the demands of the modern battlefield. SIRFC provides the accurate threat warning information and robust countermeasures capabilities you need, and can rely on. It identifies radar detection and threat lethality envelopes. SIRFC also fuses its

data with other sensors to give you a complete picture of air defense threats on the battlefield — total situational awareness. With SIRFC, you can fly with confidence in your ability to evade or defeat enemy threats, stay focused on your critical mission ... and get home safely.

**ITT** Defense &  
Electronics

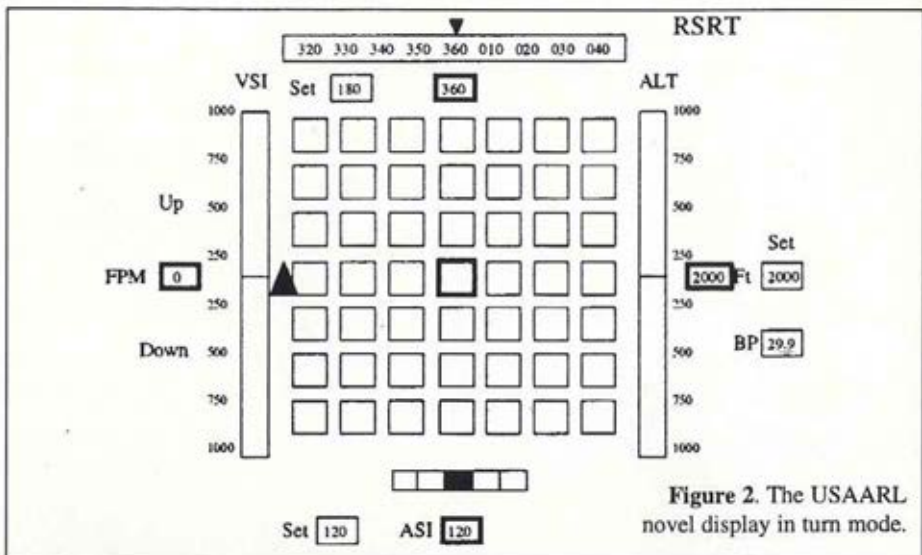

Figure 2. The USAARL novel display in turn mode.

line on the x axis. Lateral cyclic movements do the same for the heading using the y axis. Thus, if the triangle is kept in the central box, the aircraft will remain steady on both the desired speed and heading.

Altitude is color coded – the triangle is green if the altitude is +1-20 feet of the desired parameter, red if it is low, and blue if it is high. The "altimeter" to the right of the squares reinforces this information by showing the specific altitude (in digital readout form) as well as the difference between the actual altitude and the desired altitude by means of a color-coded ribbon (red for "too low" and blue for "too high"). A box displays the desired (set) altitude and another shows the barometric pressure setting. The vertical speed indicator on the left of the squares acts in much the same way as the color-coded tape display of the altimeter. It is placed on the left because it responds to control inputs from the collective lever in the pilot's left hand.

The compass tape across the top of the display shows heading, and the boxes below it the desired (set) and precise heading. Airspeed is shown below the central squares as a digital readout of desired (set) and actual aircraft speed.

The essential aim when flying the display is to keep the triangle in the center box. In this way, the set parameters for heading and airspeed will be maintained or regained by moving the cyclic. Aircraft altitude and vertical speed are regulated by the collective lever.

The display has several modes to enable accurate maintenance of flight parameters (described below). In straight-and-level mode, if the collective pitch setting is correct, heading and airspeed will be maintained or returned to their set parameters by keeping the triangle in the center box. This is the default mode. Any deviation from the set parameters will be obvious, and the control movement required to regain orienta-

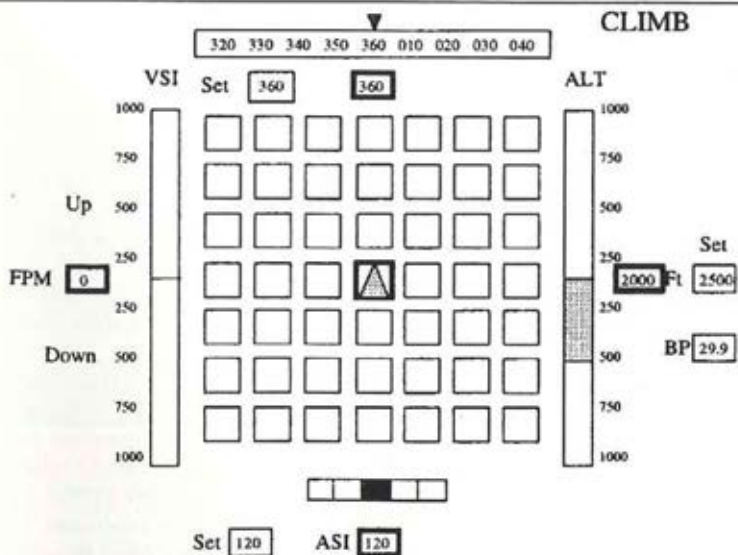

Figure 3. The USAARL novel display in climb mode (beginning of maneuver).

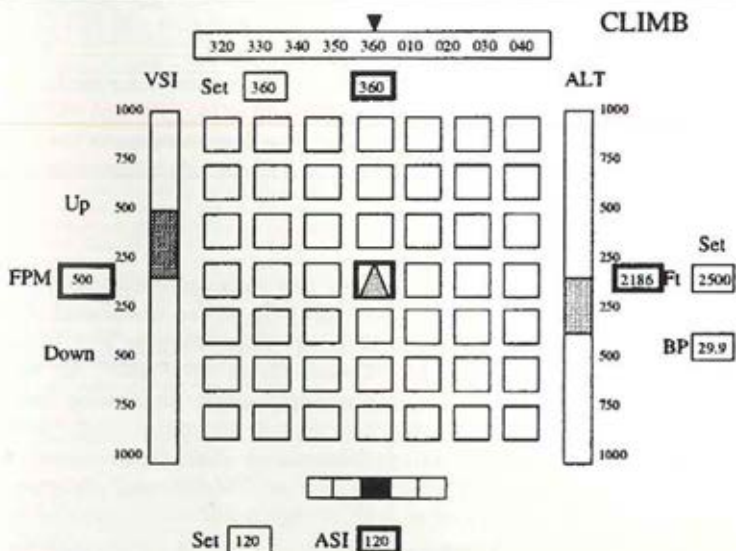

Figure 4. The USAARL novel display in climb mode (during maneuver).

tion is immediately apparent.

At the beginning of a turn (figure 2 above), the new heading is set and the triangle is initially placed off to one side (to the left in this case for a right turn). Movement of the cyclic to place the triangle in the center sets an appropriate roll angle to maintain the appropriate turn rate for that airspeed. At approximately 20 degrees from the new heading the display algorithm starts reducing the required angle of bank, and movement of the triangle in the opposite direction prompts the pilot to start rolling out of the turn.

At the start of a constant-heading climb (figure 3 left) the altitude to be achieved is set so both the altimeter ribbon and the triangle will be indicating "too low." While maintaining the triangle in the center square (to maintain heading and airspeed), collective pitch is increased so that the vertical speed ribbon indicates the desired climb rate (figure 4 left). The precise vertical speed is shown in the accompanying box. A similar arrangement of the parameters occurs during a descent, and both turns and vertical changes can easily be combined.

In an assessment conducted in the USAARL UH-60 flight simulator, 16 pilots flew a standard instrument profile and recovered from a series of unusual attitudes both with and without a secondary task.

Results from all aspects of the assessment proved the benefits of the new display. There was evidence of enhanced flight control during instrument flight; deviations from the desired value of various flight parameters (e.g., airspeed, altitude, roll angle) were significantly less when using the novel display compared to the standard flight instruments. Recovery from unusual attitudes also was improved

significantly when using the novel display; the times taken to return the aircraft to wings level and also to regain the original flight parameters were quicker. Additionally, there also was less reversal error (initially moving the cyclic stick in the wrong direction). An improved performance on a secondary task (auditory tone identification) strongly suggests that cognitive workload was significantly reduced when using the novel display compared to the standard instruments.

The display is due to be flight tested shortly in the USAARL UH-1. Some interest in the display as an improved aid to controlling unmanned aerial vehicles has already been expressed by industry. This new display clearly could not be easily retrofitted into many Army helicopters. But as the concept has been shown to significantly enhance perception of orientation with a reduced workload, it is worthy of further assessment and consideration of installation during aircraft mid-life updates and in new aircraft.

Readers who would like further information, a copy of the full USAARL technical report or a demonstration of the novel display may contact the authors directly.

\* \*

*Lt. Col. Malcolm Braithwaite, Royal Army Medical Corps, is the British Exchange Research Flight Surgeon at USAARL. Col. Simon Durnford, RAMC, is the Army Consultant Adviser in Aviation Medicine in the United Kingdom. Capt. Robert M. Wildzunas is chief of the Visual Sciences Branch at USAARL, and chairman of the DOD Human Factors Engineering Technical Advisory Group in controls, displays and voice interactive systems.*

# 1997 Aviation Warrant Officer Directory

The professional-personal roster of Active Duty Aviation Warrant officer members of AAAA that returned their questionnaires by December 5, 1997

## ROSTER CODE

Last Name, First Name, MI  
Current Grade  
(Nickname)  
Address  
Duty Phone

Residence Phone  
Name of Spouse  
Job Description  
AAAA Offices Held

**Abery John H.**, (CW4) (Jack) 2436 Arlie Manning Road, Clarksville, TN 37042-724 5. Dy: (502) 798-1938. Res: (931) 552-0462. S: Margie. Dy: Regimental Safety Officer, 160 SOAR (A), Fort Campbell, KY. Rtg: MAA. RW Qual. Time: 4,500 Hrs./Cbt 139 AM/3.

**Acosta, Anthony L.**, (CW4) (Tony) 1200 North Forest Drive, Fayetteville, NC 28303. Dy: (910) 432-7928. Res: (910) 487-4998. EM: 100347.1301@compuserve.com. Dy: 2-82 Avn Bn Stands Officer, Fort Bragg, NC. Rtg: MAA IFE SIP. RW Qual. Time: 4,100 Hrs./Cbt 44 AM/2.

**Adair, Michael S.**, (CW4) (Mike) 104 N. Oak Ridge Drive, Enterprise, AL 36330. Dy: (334) 255-3499. Res: (334) 347-2313. EM: mike\_adair@rucker-ent4.army.mil. S: Jean. Dy: Aviation Propensity Office, Fort Rucker, AL. Rtg: MAA SIP. RW Qual. Time: 1,975 Hrs. Life Member.

**Adams, Doug A.**, (CW2) 8008 Bridgeport Way SW, Apt. H, Tacoma, WA 98499. Dy: (253) 967-7851. Res: (253) 582-4069. EM: dougadams@sapintmail.com. Dy: CH-47D Pilot. Rtg: MTP. RW Qual. FW Qual. Time: 1,200 Hrs. Life Member.

**Adams, Richard E.**, (CW3) P.O. Box 64, Fort Campbell, KY 42223. Dy: (502) 798-1442. Res: (931) 645-6498. EM: handcap@sprynet.com. Dy: A Co, 1/160th SOAR (A). Rtg: IP. RW Qual. Time: 3,400 Hrs.

**Adaway, John W. III.**, (CW3) 2517 Walden Drive, Crofton, MD 21114-1147. Dy: (301) 981-6040. Res: (410) 451-6585. EM: john.adaway@andrews.af.mil. S: Joan. Dy: USAFAT, Andrews AFB, MD. Rtg: SAA IP. RW Qual. FW Qual. Time: 3,500 Hrs./Cbt 60 AM/2.

**Agee, Douglas S.**, (CW3) (Odie) A Co, 127 ASB, CMR 477, Box 942, APO AE 09165. EM: 100642.3634@compuserve.com. S: Beth. Dy: O.C. Officer, 127th ASB, Hanau, Germany. Rtg: SAA MTP. RW Qual. Time: 1,500 Hrs.

**Akins, Rex T.**, (CW3) A Co, 1-501 Avn, CMF

477, Box 2262, APO AE 09165. EM: rtaosa@compuserve.com. S: Connie. Dy: A Co, 1-501 Avn, Hanau, Germany. Rtg: MTP. RW Qual. Time: 1,500 Hrs.

**Alexander, Paul J.**, (CW3) (PJ) 1943 Needmore Road, Clarksville, TN 37042-4502. Dy: (502) 798-1799. Res: (931) 645-4047. EM: mhav@or@aol.com. Dy: Pilot, MH-47E, A Co, 2/160th SOAR (A). Rtg: IP IFE. RW Qual. Time: 2,000 Hrs./Cbt 51 AM/1.

**Almeraz, Frank.**, (CW2) 121 N. Harris Drive, Fort Rucker, AL 36362. Dy: (334) 255-4250. Res: (334) 598-8274. EM: almeraz@snowhill.com. S: Christine. Dy: OH-58C IP, Lowe AHP, Fort Rucker. Rtg: IP IFE. RW Qual. Time: 1,450 Hrs.

**Aine, Marty P.**, (CW2) 1418 Hampstead Avenue, Fairbanks, AK 99701. Dy: (907) 353-7008. Res: (907) 479-8846. S: Sandy. Dy: D Co, 4-123 Avn, Fort Wainwright, AK. RW Qual. Time: 500 Hrs.

**Alspaugh, John.**, (CW3) 2031 Ruby Drive, Barstow, CA 92311. Dy: (760) 254-3085. Res: (760) 252-7611. S: Christine. Dy: UH-1UH-60 Pilot, NTC Avn Co. Rtg: SAA. RW Qual. Time: 1,352 Hrs./Cbt 54 AM/1.

**Altman, Durwood K.**, (CW2) (Kevin) C Troop, 1/6 Cav, Box 23, APO AP 96297. S: Sherri. RW Qual. Time: 300 Hrs.

**Amegin, Peter G.**, (WO1) (Guy) 102 Iroquois Drive, Enterprise, AL 36330. Dy: (334) 255-9730. Res: (334) 347-4671. S: Kristin.

**Anders, Donald G.**, (CW4) 601 Christina Circle, Harker Heights, TX 76548. Dy: (254) 288-3373. Res: (254) 698-1196. Dy: Standardization IP, HHC, 2-4 Avn, 4ID. Rtg: IFE SIP. RW Qual. Time: 5,600 Hrs.

**Anderson, Alvin P.**, (CW3) (Andy) 1215 Powder House Drive, Newport News, VA 23608. Dy: (757) 878-1603. Res: (757) 833-6918. EM: bigalanderson@juno.com. S: Tammy. Rtg: SAA MTP. RW Qual. Time: 1,600 Hrs./Cbt 50 AM/1.

**Arnold, Kristi M.**, (WO1) 309 Access Street,

Enterprise, AL 36330. Dy: (334) 255-9960. Res: (334) 393-9668. EM: kroltohead@entercomp.com. Dy: Flight School Student, B Co, 1-145th Avn. Time: 60 Hrs.

**Arsenault, Ronald L.**, (CW3) (Ron) 12838 El Evado Road, Victorville, CA 92392. Dy: (760) 254-2905. Res: (760) 245-8172. S: Debby. Dy: UH-60 IFE, NTC Avn Co. (AASLT), Fort Irwin, CA. Rtg: SIP IFE. RW Qual. Time: 3,900 Hrs./Cbt 120 AM/1. Bronze Osm.

**Ashcom, Timothy S.**, (CW2) (Tim) 6 Bitterroot Lane, Savannah, GA 31419. Dy: (912) 692-8652. Res: (912) 920-4959. EM: tsa8786@aol.com. S: Ingrid. Dy: Aviation Maintenance Technician, A Co, 603d ASB, HAAF, GA.

**Babcock, Myron F.**, (CW5) (Myron) 423 Ketchikan Avenue, Fairbanks, AK 99701-3736. Dy: (907) 353-7097. Res: (907) 455-4925. EM: mbabcock@polamet.com. S: Linda. Dy: USARAK Standardization/Deputy Aviation Officer, Fort Wainwright, AK. Rtg: MAA SIP. RW Qual. Time: 5,800 Hrs. AM/1. 88 Avn/O of Year.

**Bailey, Michelle J.**, (CW2) 2702 Jade Road, Killeen, TX 76543. Dy: (254) 287-1370. Res: (254) 680-5389. Dy: E Trp, 1-7 Cav, Fort Hood, TX. RW Qual.

**Baker, Sam R.**, (CW2) (Sammy) 1411 McClardy Road, Clarksville, TN 37042-6700. Dy: (502) 798-5438. Res: (931) 551-4392. EM: bakera@knighthwave.com. S: Angela. Dy: B Company, 7th Bn, 101st Avn Regt, Fort Campbell, KY. Rtg: AA AW/O. RW Qual. Time: 700 Hrs.

**Ballard, Ian S.**, (CW2) (Duckman) 1429 Gill Street 448C, Watertown, NY 13601. Dy: (315) 772-5194. Res: (315) 785-0967. S: Esther. Dy: A Co, 2-10 Avn Rgt, "Voodoo Strike Force", Fort Drum, NY. RW Qual. FW Qual. Time: 400 Hrs.

**Ballard, Kevin D.**, (CW2) PSC 1, Box 2295, APO AA 34001. Dy: (507) 284-6953. Res: (507) 283-6145. EM: kbllard@usanso-lan1.army.mil. Dy: Instructor, C Co, 1-228th

Avn Regt. Rtg: SIP. RW Qual. Time: 1,280 Hrs.

**Barber, Carl B.,** (CW2) 94-161 Kuakelan Avenue, Unit 165, Millani Town, HI 96789. Dy: (808) 656-9001. Res: (808) 627-0176. S: Jennifer. Rtg: 68th Medevac Detachment, Wheeler AAF, HI. RW Qual. Time: 450 Hrs.

**Bartol, John P.,** (CW5) (Jack) 116 Nancy Drive, Enterprise, AL 36330. Dy: (334) 255-2531. Res: (334) 393-0593. Rtg: AH-64 SP, DES, Fort Rucker, AL. Rtg: MAA. RW Qual. Time: 3,600 Hrs. AM/3, DFC1.

**Baruzzini, Murray B.,** (CW2) (Brent) P.O. Box 96, La Fayette, KY 42254-0096. Dy: (502) 798-5301. Res: (502) 271-8547. S: Kimberley. Dy: A Co, 8-101 Avn, Fort Campbell, KY. Rtg: AA MTP. RW Qual. Time: 1,000 Hrs.

**Bass, Ed,** (CW3) Unit 15008, Box 219, APO AP 96208. EM: edobobbie@central.net. S: Bobbie. Dy: AH-64 MTP, Camp Page, ROK. Rtg: SAA MTP. RW Qual. Time: 1,700 Hrs./Ct 50

**Batz, Paul L.,** (CW2) 1406-B Eagle Loop, Fort Campbell, KY 42223-3510. Dy: (502) 798-7267. Res: (931) 431-4423. EM: avblor@juno.com. S: Tehdi. Dy: 503 Medical Company (AA), Fort Campbell, KY. RW Qual. Time: 360 Hrs.

**Battleson, Rebecca J.,** (WO1) (Becky) 104 Fuqua Avenue, Ozark, AL 36360. Res: (334) 774-4468. RW Qual.

**Beam, James A.,** (CW3) (Jim) 9646 Regency Loop SE, Olympia, WA 98513. Dy: (253) 967-2414. Res: (360) 413-9275. EM: jimbeam1@ix.netcom.com. S: Mary. Dy: Fort Lewis Regional Flight Center, Fort Lewis, WA. Rtg: SAA. RW Qual. FW Qual. Time: 4,600 Hrs.

**BEAMAN, Robert L.,** (CW5) (Bob) HHC, 8th PERSCOM TARO, Box 518, Unit 15279, APO AP 96205-5000. EM: eapc-ro@emh9.arpa.army.mil. S: Jo. Dy: Theater Strength Manager (Avn), Yongsan, Korea. Rtg: MAA SIP. RW Qual. Time: 4,900 Hrs. Bronze Osm.

**Bean, Duward C.,** (CW3) (D.C.) 672 A Infantry Post Road, Fort Sam Houston, TX 78234-1302. Res: (210) 223-6605. EM: dbean2@aol.com. S: Cynthia. Dy: 542nd Med Co, APO AP. Rtg: IFE SIP. RW Qual. Time: 3,500 Hrs./Ct 50

**Bean, Keith O.,** (WO1) (Stickma) 115 N. Harris, Fort Rucker, AL 36362-2347. Dy: (334) 255-9961. Res: (334) 598-5156. EM: mearv@aol.com. S: Ann. Dy: 153C, Camp Humphries, Korea. 2-52nd B Co, RW Qual.

**Beebe, Sandra L.,** (CW5) 1574 Carrington Avenue, Winter Springs, FL 32708-6127. Res: (407) 977-8464. S: Steven. Rtg: MAA IFE SIP MTP. RW Qual. FW Qual. Time: 6,200 Hrs.

**Bell, Brian L.,** (CW2) 501 Geri Drive, Copperas Cove, TX 76222. Dy: (254) 289-2048. EM: bibell@sagetel.net. S: Ellen. Dy: D Tpt, 1-7 Cav Avn Regt, Fort Hood, TX. Rtg: MTP. RW Qual. Time: 1,550 Hrs.

**Bellamy, Jay,** (CW4) (Jay) 8217 Chivalry Road, Annandale, VA 22003. Res: (703) 560-1035. EM: bellamy@erols.com. S: Maureen. Dy: B Co, 12th Avn Bn, Fort Belvoir, VA. Rtg: MAA IFE SIP. RW Qual.

Time: 4,675 Hrs./Ct 50 AM/1. Past Chapter Officer.

**Benton, Michael D.,** (WO1) (Mike) 5931-B Bernet Court, Fort Polk, LA 71459. Res: (318) 537-0145. S: Melissa. Dy: O Tpt, 4/2 ACR. RW Qual. Time: 200 Hrs.

**Bentson, Matthew K.,** (CW3) 6453 Yellow Stone Drive, Columbus, GA 31909. Dy: (706) 545-8090. Res: (706) 569-8545. EM: bentsonm@benning-emh2.army.mil. S: Katrina. Dy: UH-60 IP, DOT Avn, Fort Benning. Rtg: IP. RW Qual. Time: 2,400 Hrs./Ct 14 AM/1.

**Bergstad, Darrin S.,** (CW2) 1671 Fort Campbell Blvd., Apt. W11, Clarksville, TN 37042. Dy: (502) 798-4560. Res: (931) 552-9234. EM: bergstadd@campbell-emh5.army.mil. Dy: UH60 Pilot, A-6-101 Avn, Fort Campbell, KY. RW Qual. FW Qual. Time: 300 Hrs.

**Biddulph, Kenneth G.,** (WO1) 220 Windmade Circle, Clarksville, TN 37042. Dy: (931) 798-4564. Res: (931) 647-9047. S: Heidi. Dy: B Co, 6-101st Avn, Fort Campbell, KY. RW Qual. FW Qual. Time: 300 Hrs.

**Black, Frank M.,** (CW3) (Gus) 21 Donavan Lane, Fort Rucker, AL 36362. Dy: (334) 255-6210. S: Andrea. Dy: A Co, 1-223 Avn Regt, Fort Rucker, AL. Rtg: SAA MTFE. RW Qual. Time: 1,650 Hrs./Ct 100 AM/2.

**Blaney, William H.,** (CW5) 2946 Sweet Gum Ct., Woodbridge, VA 22192. Dy: (703) 806-7062. Res: (703) 491-5539. EM: blaneyw@airfield-belvoir.army.mil. S: Deborah. Dy: Standardization Offic, 12th Aviation Battalion, Fort Belvoir, VA. Rtg: MAA IFE SIP IP. RW Qual.

**Bonino, Robert K.,** (CW2) B Co, 2-501st Avn Regt, CMR 477, Box 1194, APO AE 09165. EM: 100650.3047@compuserve.com. S: Krista. Dy: UH-60 Helicopter Pilot, Hanau Army Airfield. RW Qual. Time: 850 Hrs.

**Boren, Jason C.,** (WO1) P.O. Box 620274, Fort Rucker, AL 36362-0274. Dy: (334) 255-2039. Res: (334) 598-2603. S: Tiffany. Dy: Apaches to Korea. RW Qual. Time: 160 Hrs.

**Boisen, R. Matthew,** (CW2) (Matt) P.O. Box 1485, Delta Junction, AK 99737. Dy: (907) 873-4170. Res: (907) 869-3551. EM: botnen@hotmail.com. S: Heather. Dy: UH-1 Pilot, Fort Greely, AK. Rtg: AA. RW Qual. Time: 1,000 Hrs.

**Bottom, Robert G.,** (CW2(P)) (Bob) 403 Broken Arrow Drive, Enterprise, AL 36330. Dy: (334) 255-8562. Res: (334) 393-6125. EM: rbottom@snwhill.com. S: Susan. Dy: C Co, 1-223rd Avn, Fort Rucker, AL. Rtg: SAA IP. RW Qual. Time: 1,600 Hrs. AM/1.

**Bowser, Herman S.,** (WO1) (Scott) 3828 Clearwater Drive, Fayetteville, NC 28311. Res: (910) 822-9624. S: Gretchen.

**Bradford, Ronald F.,** (CW4) (Skip) 348 Sunset Court, Cadiz, KY 42211. Dy: (502) 798-1874. Res: (502) 522-8936. S: Nancy. Dy: 160th SOAR (Airborne), Fort Campbell. Rtg: SAA MTP ME. RW Qual. Time: 2,500 Hrs./Ct 43 AM/1.

**Brandli, Thomas S.,** (CW4) AFOD, Unit 29231, Box 61, APO AE 09102. EM: brandli@hq.hqsarsur.army.mil. S: Angie. Dy:

USAREUR CH47 SP & AFOD Operations Officer. Rtg: SIP IFE. RW Qual. FW Qual. Time: 4,000 Hrs. Life Member.

**Braun, Donald T.,** (CW4) (Don) 927 Herons Run Lane, Woodbridge, VA 22191-1349. Dy: (703) 706-1217. Res: (703) 491-1764. EM: donbraun@aol.com. S: Yong Ok. Dy: INSCOM Headquarters, Fort Belvoir, VA. Rtg: SAA SIP IFE ME. RW Qual. FW Qual. Time: 5,600 Hrs.

**Breckons, Sanford D.,** (CW5) (Sandy) 5008 Creekside Drive, Killeen, TX 76543. Dy: (254) 287-8325. Res: (254) 699-8501. S: Yvonne. Dy: III Corps Flight Standards, Fort Hood, TX. Rtg: MAA SIP IP IFE. RW Qual. Time: 4,800 Hrs. AM/17.

**Breithaupt, Andrew B.,** (CW2) 507 Antler Drive, Enterprise, AL 36330. Dy: (334) 255-5056. Res: (334) 347-4638. EM: breithau@snwhill.com. S: Holly. Dy: AH-64 Instructor Pilot, D Co, 1-14th Avn Regt. IP. RW Qual. Time: 800 Hrs.

**Brodhead, Kenneth G.,** (CW2) (Kenney) 91-881 Wallewa Place, Ewa Beach, HI 96706. Dy: (808) 656-1322. Res: (808) 685-1160. EM: brodhead@pixi.com. S: Josephine. Dy: UH-60 Pilot, B Co, 2-25 Aviation Regt, Wheeler AAF, HI. RW Qual. FW Qual. Time: 500 Hrs.

**Brosnan, John F.,** (CW3) (Johnny) 107 Harrant Creek Drive, Enterprise, AL 36330-3645. Dy: (334) 255-4669. S: Jill. Dy: Battalion Operations Officer, E Co, 1-212th Avn Regt. Rtg: SAA IP. RW Qual. Time: 2,500 Hrs.

**Brown, Clifford L.,** (CW5) (Cliff) 205 Keims Court, Ozark, AL 36360. Dy: (706) 545-2546. Res: (334) 774-0043. EM: cliffbrown2@juno.com. S: Dottie. Dy: Deputy Director of Operations and Training, Fort Benning, GA. Rtg: MAA IFE SIP. RW Qual. Time: 6,000 Hrs./Ct 670 DFC21, AM/2.

**Brown, Cody L.,** (CW2) (Cody) 205 Keims Court, Ozark, AL 36360-6263. Dy: (334) 774-0043. Res: (334) 774-0043. EM: eaav-2bn-a-cbrown@emh2.korea.army.mil. S: Casey. Dy: Operations Officer, A Co, 2-52nd Avn Regt, ROK. Rtg: AA. RW Qual. Time: 700 Hrs.

**Brown, Douglas B.,** (CW3) (Doug) OMC/AV Apache Tail, Unit 64901 Box 18, APO AE 09839-4901. Res: (334) 393-3574. EM: cw3dub@aol.com. S: Frances. Dy: Technical Assistance Fielding Team, AH-64, Cairo, Egypt. Rtg: IP. RW Qual. Time: 3,100 Hrs./Ct 50 AM/1. Secretary, Nile Delta Chapter.

**Brown, Gary P.,** (CW2) 34 Tiara Park, Fort Rucker, AL 36362. Dy: (334) 255-9961. Res: (334) 598-2741. S: Diana. Dy: CH-47 Pilot, Camp Humphries, Korea. Rtg: AA. RW Qual. Time: 350 Hrs.

**Brunetti, Brian B.,** (CW2) 213 East Hickory Bend, Enterprise, AL 36330. Dy: (334) 255-9427. Res: (334) 393-9372. EM: brinbrn@snwhill.com. Rtg: Pilot, Flatiron (Air Ambulance), RW Qual. Time: 1,100 Hrs.

**Buck, Stanley J.,** (CW3) 210 Ashbrooke Lane, Clarksville, TN 37043-4025. Res: (931) 586-5353. EM: bucks@campbell-emh5.army.mil. S: Jean. Dy: HHC, 5-101st Avn,

Fort Campbell, RW Qual. Time: 1,500 Hrs.

**Bukowski, Michael**, (CW3/P) CMR 430, Box 1216, APO AE 09086. EM: bukowski@wiesbaden.netsurf.de. S: Gayle. Dy: A Co, 5/158 Avn Regt, Wiesbaden Air Base, Germany. Rtg: IP. RW Qual. FW Qual. Time: 5,000 Hrs. AM2/1V.

**Burdis, John M.**, (CW2) (Malcolm) P.O. Box 41, Fort Drum, NY 13603. Dy: (315) 772-6488. Res: (315) 786-7926. S: Mary. Dy: LH-60 Pilot.

**Burhans, James R.**, (CW3) (Jim) P.O. Box 602073, Fort Rucker, AL 36362-0273. Dy: (334) 255-2532. Dy: DES, Fort Rucker. Rtg: IP. ME. RW Qual. Time: 1,800 Hrs. Past Chapter Officer.

**Burnett, Peter R.**, (CW5) (Pete) 10211 Sam-Neil Road, Salado, TX 76571. Dy: (817) 287-8339. Res: (817) 947-4477. S: Maryvonne. Dy: Corps Sides Officer, Fort Hood. Tx. Rtg: SIP. RW Qual. Time: 5,600 Hrs./Cbt 1,000 AM2/3.

**Burt, Garth C.**, (CW5) 4026 Herring Drive, Corpus Christi, TX 78418-3176. Dy: (512) 939-3166. Res: (512) 937-7007. EM: gburth@ccad-cadgate.army.mil. S: Linda. Dy: CCAD Chief, Aviation Division. Rtg: ME. RW Qual. Time: 3,800 Hrs.

**Bushong, Benjamin P.**, (CW2) (Ben) 3809 Nassau Circle, Apt. 6-A, Hopkinsville, KY 42250-5380. Dy: (502) 798-1799. Res: (502) 889-0694. EM: bushongb@soar.net. Dy: A Co, 2-180 SOAR, Fort Campbell, KY. RW Qual. FW Qual. Time: 1,100 Hrs.

**Byler, Glenn R.**, (WO1) 84N Harris Drive, Fort Rucker, AL 36362. Dy: (334) 255-9941. Res: (334) 598-2547. S: Debra. RW Qual. FW Qual. Time: 160 Hrs.

**Cadwell, Neil S.**, (CW3) 3460 Hickory Hill Drive, Colorado Springs, CO 80906. Dy: (719) 526-4752. Res: (719) 540-6548. S: Lori. Dy: R Tpt, 4/3 ACR, Fort Carson. Rtg: SIP. RW Qual. Time: 5,500 Hrs.

**Cagle, Michael J.**, (WO1) 349-7 Waterdown Drive, Fayetteville, NC 28314. Dy: (910) 396-2315. Res: (910) 860-3482. EM: cptgogles@aol.com. RW Qual. Time: 475 Hrs.

**Cardoza, Andre A.**, (CW2) (Dr Dre) CMR 416, Box 194, APO AE 09140. Dy: Pilot, A2-6 Cav. Rtg: ASO. RW Qual. FW Qual. Time: 1,060 Hrs.

**Carpenter-Bass, Bobbie S.**, (CW2) (Bobbie) Unit 15008, Box 219, APO AP 96205. EM: edobtie@central.net. S: Edward. Dy: A Co, 1-2 Avn, Camp Page, Korea. Rtg: MTP. RW Qual. Time: 550 Hrs.

**Carr, Danielle M.**, (CW2) 1410 Hempstead Avenue, Fairbanks, AK 99701. Dy: (907) 353-2224. Res: (907) 474-0425. EM: dani@mosquitonet.com. Dy: 4123 Avn Bn, Fort Wainwright, AK. RW Qual.

**Carver, Brian H.**, (CW2) 1227 Oak Knolls Drive, Fayetteville, NC 28314. Dy: (910) 396-7349. Res: (910) 864-2781. EM: boaverc007@aol.com. S: Dawn. Dy: A Co, 1-82 Avn Regt, Fort Bragg, NC. RW Qual. Time: 330 Hrs.

**Cater, Timothy W.**, (WO1) (Tim) 2543 Silverbell Loop, Fayetteville, NC 28304. Dy: (910) 396-6541. Res: (910) 423-2720. S: Sonya. Dy: 57 Medical Company (AA), Fort

Bragg, NC. RW Qual. Time: 350 Hrs.

**Chalupsky, Jan D.**, (CW5) (Enlorce) 605 San Fernando Place, Colorado Springs, CO 80906. Dy: (719) 526-9857. Res: (719) 576-7142. EM: chalupskyj@carsonemil1.army.mil. S: Cheryl. Dy: Installation XXI TAC Ops Off, Fort Carson, CO. Rtg: MAA IFE SIP. RW Qual. FW Qual. Time: 4,000 Hrs.

**Chance, Christopher**, (CW2) (Chris) 423 Sarah Drive, Clarksville, TN 37042. Dy: (502) 798-4284. EM: chris58d@aol.com. Dy: Aerospace Pilot, Fort Campbell, KY. RW Qual. Time: 400 Hrs.

**Choate, Donald R.**, (CW3) (Don) 818 Ringold Street, Wahiawa, HI 96786-3834. Dy: (808) 656-1201. Res: (808) 624-9424. EM: don\_choate@juno.com. S: Loren. Dy: AD, Wheeler Army Airfield, HI. Rtg: SAA MTP. RW Qual. Time: 2,370 Hrs./Cbt 40 AM1/1.

**Chretien, Gregory S.**, (CW2) (Creator) 5120 Pelham Street, No. 1, Fort Riley, KS 66442-1424. Res: (913) 784-5561. S: Kathy. RW Qual. FW Qual. Time: 850 Hrs.

**Church, William A.**, (CW4) (Bill) 701 Morris Drive, Copperas Cove, TX 76522. Dy: (254) 288-3534. Res: (254) 547-6638. EM: churchw@vwm.com. S: Jae Seol. Dy: Standardization Officer, 1-10 Cav 4 ID, Fort Hood, TX. Rtg: MAA SIP IFE. RW Qual. Time: 6,200 Hrs.

**Clapp, Mark A.**, (CW2) (Clapper) 206 Welston Drive, Enterprise, AL 36330. Res: (334) 347-8966. S: Erin. Dy: C Co, 1-14th Avn Regt, Fort Rucker, AL. Rtg: AA IP. RW Qual. Time: 1,000 Hrs.

**Clark, William J.**, (CW5) (Bill) 185 Rolling Brook Trail, Fayetteville, GA 30215. Dy: (404) 464-7317. Res: (770) 716-8606. EM: clarkb@forscom.army.mil. S: Carol. Dy: Avn Assignment Manager, FORSCOM HQ, Fort McPherson, GA. Rtg: IFE SIP. RW Qual. FW Qual. Time: 7,000 Hrs./Cbt 1,025 DFC1/AM22.

**Clarke, Margaret P.**, (CW2) (Margol) A Co, 1-2 Avn Regt, Unit 15008, Box 101, APO AP 96208. EM: attackgirl@aol.com. Dy: AH64 Pilot, 1/01st, Fort Campbell, KY. Rtg: AA. RW Qual.

**Clayton, William L.**, (CW2) (Will) 2021 Rishel Drive, No. B, Fort Campbell, KY 42223. S: Brenda. Dy: A Co, 4-101st Avn. Rtg: MTP. RW Qual.

**Close, Bert W.**, (CWO) 511-D Sleepy Hollow Road, Gouverneur, NY 13642-1571. Dy: (315) 772-3810. Res: (315) 287-0415. EM: bclose@slc.com. S: Janeen. Dy: B Co, 1-10 Avn Regt, Fort Drum, NY. Rtg: IFE IP. RW Qual. Time: 2,500 Hrs./Cbt 45 AM1. Life Member.

**Cockley, Patrick J.**, (CW2) (P.J.) 336 Candlerbrook Drive, Enterprise, AL 36330. Dy: (334) 255-5013. Res: (334) 308-1817. Dy: Molineville Aerial Gunnery Range Complex OIC, Fort Rucker, AL. RW Qual. Time: 500 Hrs.

**Coates, David A.**, (CW5) (Dave) 255 Shilling Way, Newman, GA 30263. Dy: (404) 464-6572. Res: (770) 502-1474. EM: coated@forscom.army.mil. S: Patricia. Dy: FORSCOM Standardization Officer, Fort

McPherson, GA. Rtg: MAA IFE SIP IP TP. RW Qual. Time: 4,400 Hrs./Cbt 700 AM2/9. Past Chapter Officer.

**Coder, Dean R.**, (CW5) (Bob) 811 E Victory Drive, Savannah, GA 31405-2421. Dy: (912) 352-5872. Res: (912) 234-2734. EM: coderr@soar.com. S: Trish. Dy: 3/160th SOAR (A), Hunter Army Airfield, GA. Rtg: MAA. RW Qual. FW Qual. Time: 6,000 Hrs./Cbt 950 Past Chapter Officer. 86 McClellan, Osm.

**Coleman, Edward A.**, (CW2) (Johnson) 380 Sango Road, Clarksville, TN 37043. Res: (931) 358-9652. S: Johnny. Dy: USASD, Fort Jackson, SC. Duty at Embury Riddle, Fort Campbell, KY. Rtg: AA. RW Qual. Time: 1,100 Hrs.

**Condon, Wendall A.**, (CW4) (Spike) HHC 5-158th Avn Regt, CMR 408, Box 975, APO AE 09182. S: Lori. Dy: 5-158 Avn Bn SIP, Giebelstadt, Germany. Rtg: IP. RW Qual. Time: 3,800 Hrs. Vp, Membership Enrollment, Mission Ready Chapter.

**Conlin, Curt R.**, (CW2) CMR 408, Box 1718, APO AE 09180. EM: conlin\_c@hotmail.com. S: Teri-Gene. Dy: ALSE Officer, 236 Med Co. Rtg: AA. RW Qual. Time: 500 Hrs.

**Cornell, Thomas E.**, (CW5) 16077 Salvo Drive, Temple, TX 76702-6550. Dy: (817) 287-8590. Res: (817) 986-8326. EM: connell@horod-amb3.army.mil. S: Jean. Dy: Chief, III Corps, Flight Sids Branch. Rtg: TP. RW Qual. Time: 6,017 Hrs./Cbt 1,496 AM4/7.

**Cormey, David S.**, (CW3) (Face) C Troop, 2-6 Cav, CMR 416, Box 24, APO AE 09140. EM: 102104.1124d.compuserve.com. S: Juliann. Dy: SPIIE, 2-6 Cav. Rtg: SAA IFE SIP. RW Qual. Time: 2,600 Hrs.

**Cornell, James R.**, (WO1) (Jim) 117 Lightfoot Drive, Enterprise, AL 36330. Dy: (334) 255-9944. Res: (334) 347-6490. S: Vicky. Dy: B Co, 1/145th. Time: 109 Hrs.

**Cornelius, Christopher**, (CW2) 14531 Range Park Place, Poway, CA 92064-3108. Res: (619) 748-7572. EM: cornelius7097@hotmail.com. S: Lynn. Dy: 2/5 Cav/C Trp, Illshelm, Germany. RW Qual. Time: 300 Hrs.

**Cote, Rick J.**, (CW2) 5491 Hobmont Drive, Fayetteville, NC 28306. Dy: (910) 907-7045. Res: (910) 424-1265. EM: coyote1243@aol.com. S: Teri. Dy: 57th Med Co, Fort Bragg, NC. RW Qual. Time: 400 Hrs.

**Courtland, Joann L.**, (CW2) P.O. Box 16, Great Bend, NY 13643-0016. Dy: (315) 772-3801. S: Christopher. Dy: A Co, 1st Bn (Attack), 10th Avn Regt, Fort Drum, NY. RW Qual. Time: 470 Hrs.

**Cranford, Andrew C.**, (CW2) (Drew) C Co, 2-1 Avn, CMR 454, Box 2215, APO AE 09250. EM: acranford@sprynet.com. S: Karin. Dy: EH-60 MTP, Katterbach, Germany. Rtg: MTP. RW Qual. Time: 1,400 Hrs.

**Cronrath, Michael R.**, (CW3) 29 Logan Street, Fort Rucker, AL 36362. Dy: (334) 255-3432. Res: (334) 598-6104. EM: cronrath@juno.com. S: Joanne. Dy: 1st WOC/WOCC, Fort Rucker, AL. Rtg: ASO. RW Qual. Time: 1,200 Hrs./Cbt 70 AM1/1.

**Crooker, David G.**, (CW2) (Crook) 647 Wainwright Road, Fort Wainwright, AK

99703. Dy: (907) 353-7008. Res: (907) 356-1835. EM: dcrocker@polarnet.com. S: Jacqueline. Dy: 153D UH-60 Pilot, D Co, 4-123 Avn. RW Qual. Time: 600 Hrs.

**Crothers, Sean C.**, (CW3(P)) 32 Luzon Drive, Fort Bragg, NC 28307-1855. Dy: (910) 396-5792. Res: (910) 497-8715. EM: scrothers@aol.com. S: Son M. Dy: C Company, 159th Avn Regt, Fort Bragg, NC. Rtg: SAA IP. RW Qual. Time: 4,275 Hrs./Cbt 95 AM/3. Life Member.

**Crownover, Jeffery T.**, (WO1) 362 Brockridge Road, Woodlawn, TN 37191. Res: (913) 906-1087. EM: crown3@compuserve.com. S: Claire. Dy: Fort Campbell, KY, AH-64 Pilot. RW Qual. Time: 230 Hrs.

**Culler, David A.**, (CW2) (Doom) A Trp, 2-6 Cav, CMR 416, Box 262, APO AE 09140. EM: culler64@aol.com. S: Gretchen. Dy: AH 64 MPT, Ilshheim, Germany. Rtg: SAA MTP. RW Qual. Time: 1,400 Hrs./Cbt 30 AM/2.

**Cupit, Randy E.**, (CW3) (Bear) 9901-A Bready Loop, Fort Drum, NY 13603. Dy: (315) 772-9573. Res: (315) 773-0530. S: Ann. Dy: UH-60 Maintenance Test Pilot. Rtg: AA MTP. RW Qual. Time: 2,000 Hrs./Cbt 225.

**Cupp, Jeffrey L.**, (CW3) CMR 477, Box 1618, APO AE 09165. EM: JeffreyCupp@compuserve.com. S: Georgina. Dy: Co Safety Officer, C Co, 2-501st Avn. RW Qual. Time: 2,800 Hrs.

**Curry, Daniel R.**, (CW3(P)) 2317 Overbrook Lane, Bedford, VA 76021. Dy: (817) 280-7823. Dy: Acceptance Test Pilot, DCMC Bell Helicopter Textron. Rtg: SAA SIP MTP. RW Qual. Time: 3,000 Hrs./Cbt 60 DFC1, AM2, IV.

**Czarnecki, Kenneth**, (CW2) (Kenny) 17 Donovan Street, Fort Rucker, AL 36362. Dy: (334) 255-8288. Res: (334) 598-5234. EM: koczarecki@aiaa.net. S: Lori. Dy: UH-60/UH-1 Project Pilot, USAATTC, Fort Rucker, AL. Rtg: IFE IP. RW Qual. Time: 1,850 Hrs.

**Dabney, Troy C.**, (CW2) 7280-C Iwo Jima Drive, Fort Carson, CO 80913-2284. Dy: (719) 526-8237. Res: (719) 538-0726. EM: tsabney628@aol.com. S: Cathlene. Dy: S Trp, 43R (MTP), Fort Carson, CO. Rtg: MTP. RW Qual. Time: 700 Hrs.

**Dalgis, Joseph W.**, (WO1) (Joe) 99 N Harris Dr., Fort Rucker, AL 36362. Dy: (334) 255-9960. Res: (334) 598-9107. S: Kimberly. Dy: B Co, 1/145th Avn Bn. Tmp: 75 Hrs.

**Daley, Timothy A.**, (WO1) 27 Edwards, Fort Rucker, AL 36362. Res: (334) 598-6285. S: Tracy. RW Qual. AM/1.

**Dalton, Alan F.**, (CW3) 68-121 Au Street, No. 408, Wailua, HI 96791. Dy: (808) 656-2543. Res: (808) 637-5999. EM: toyouth@ih@aol.com. Dy: UH-60 IP, B Co, 2-25th Avn, WAAF, HI. Rtg: IP. RW Qual. Time: 2,000 Hrs.

**Darlington, Kenneth R.**, (CW2) CMR 430, Box 133, APO AE 09096. EM: darlington\_jk@msn.com. Dy: 1st Military Intelligence Bn, Wiesbaden, Germany. RW Qual. RW Qual. Time: 1,300 Hrs. AM/2.

**Davidson, Stephen L.**, (CW5) (Boomer) 943 Edgewater Drive, Newport News, VA 23602-8834. EM: sdavidson@optec@army.mil. S: Connie. Dy: Threat Support Activity, Fort Bliss, TX. Rtg: MAA SIP. RW

Qual. RW Qual. Time: 11,120 Hrs./Cbt 1,995 DFC3, AM/56. Life Member. Past Chapter Officer.

**Davis, Guy E. Jr.**, (CW2) 111 Stoneleigh Road, Turnbull, Ct 06611-3319. EM: sdavis@snet.net. S: Sheryl. Dy: A-12 Avn Regt, Unit 15008, APO AP 96208, South Korea. RW Qual.

**Davis, John P.**, (CW3) 1092 Biltmore Place, Clarksville, TN 37042. Dy: (502) 798-2781. Res: (931) 431-3086. EM: chieldavis@mid-south.net. S: Mary. Dy: AH-64 IP, Fort Campbell, KY. Rtg: IP. RW Qual. Time: 1,500 Hrs.

**Day, Todd J.**, (CW2) P.O. Box 35452, Fort Wainwright, AK 99703. Dy: (907) 353-6861. Res: (907) 490-2363. EM: tday@junco.com. S: Lynnda. Dy: UH-60 IP, D Co, 4-123rd Avn, Fort Wainwright, AK. Rtg: IP. RW Qual. RW Qual. Time: 2,300 Hrs.

**Deaner, Paul H.**, (CW3) (Bear) 27 Oakmont Court, Clayton, NC 27520. S: Brenda. Dy: Maint. Test Pilot, 1-6 Cav Bn, Fort Eagle, Korea. Life Member.

**Deedon, Raymond E.**, (CW2) B Co, 1-1 Avn, CMR 454, Box 2283, APO AE 09250. EM: 998276936-0001@Lonline.de. S: Danielle. Dy: AH-64 Pilot, Katterbach, Germany. RW Qual. Time: 500 Hrs.

**De Golyer, Troy A.**, (CW3) (T-Roy) P.O. Box 510, Fort Knox, KY 40121. Dy: (502) 624-7108. Res: (502) 877-6192. EM: degolyer@tkknow-emh9.army.mil. Dy: TSB (Avn) Knox, Fort Knox, KY. RW Qual. Time: 1,400 Hrs./Cbt 60 AM/2. Life Member.

**DeGroff, Lawrence S.**, (CW2) (Lamy) 22 Galt Lane, Fort Rucker, AL 36362. Dy: (334) 255-4606. Res: (334) 598-8155. EM: idegroff@aiaa.net. S: Dawn. Dy: IP, C Co, 1-212th Avn. Rtg: IP. RW Qual. Time: 1,700 Hrs.

**Dehr, Lester F.**, (CW4) 357 Deepwood Trail, Clarksville, TN 37042. Dy: (502) 798-5502. EM: ldehr@aol.com. S: Laura. Dy: Bn Avn Maint Officer, HHC, 7-101st Avn. Rtg: MTP MTFE. RW Qual. Time: 2,100 Hrs./Cbt 20 AM/2.

**DeJesus, Melvin**, (WO1) (Roach) 321 Highland Avenue, Eufaula, AL 36027. Dy: (334) 255-9730. Res: (334) 616-0114. S: Amanda. Dy: Flight Student, US Army Avn. School, B Co, 1/145th, Fort Rucker, AL. RW Qual. Time: 80 Hrs.

**Delahoy, David L.**, (CW4) (Big D) 165 Shasta Drive, Newport News, VA 23608. Dy: (804) 878-6367. Res: (804) 877-7412. EM: delahoyd@eustis-emh10.army.mil. S: Jerri. Dy: DTPE, TTD, Project Officer, Fort Eustis, VA. DFC2, AM6.

**Delao, Christopher**, (CW2) P.O. Box 42093, Savannah, GA 31409. Dy: (912) 352-6040. Res: (912) 920-8573. Dy: A Company, 3160 SOAR (A), Hunter AAF, GA. RW Qual. Time: 1,430 Hrs.

**Dennis, Donald W.**, (CW5) (Don) 4259 Barrett Drive, New Windsor, NY 12553. Dy: (914) 563-3298. EM: yd5957@gus.usa.army.mil. S: Carol. Dy: Commander, 2nd Avn Det, USMA, Rtg: MAA IFE IP. RW Qual. Time: 4,000 Hrs./Cbt 800 AM/32.

**Denny, Scott**, (CW3) (Scott) 207th Aviation

Company, Unit 29231, Box 132, APO AE 09102. S: Suzan. Dy: C-127 SPIE, 207th Avn Co, Heidelberg, Germany. Rtg: SAA IFE SIP IP MTP. RW Qual. RW Qual. Time: 4,500 Hrs. Life Member. Past Chapter Officer. Bronze Osm.

**Dessinger, Michael D.**, (CW2) (Mike) 213 Carlos Darling Dr. NE, Alexandria, MN 56308. EM: 113005.265@compuserve.com. S: Tonia. Dy: C Co, 1-160th, Fort Campbell, KY. RW Qual. Time: 1,350 Hrs. AM/2.

**Detty, Darrell W.**, (WO1) 507 Briarwood Drive, Apt. 13B, Enterprise, AL 36330. Dy: (334) 395-0960. Res: (334) 393-3584. S: Jacqueline. Dy: Flight School Student. Time: 61 Hrs.

**Diamond, Robert J.**, (CW2) 2911 Blue Bonnet Drive, Killeen, TX 76542. Dy: (254) 288-1471. Res: (254) 628-0143. EM: robsandra@aol.com. S: Sandra. Dy: UH-60 Pilot, A Co, 2-227th Avn. Rtg: IP. RW Qual. Time: 830 Hrs.

**Dietrich, Edwyrn**, (CW2) (Ed) P.O. Box 620574, Fort Rucker, AL 36362. Dy: (334) 255-4249. Res: (334) 598-3032. S: Deby. Dy: B Co, 1/212 Avn, Fort Rucker, AL. Rtg: IP. RW Qual.

**Dionne, Roger P.**, (CW2) (Page) 15 Ames Lane, Fort Rucker, AL 36362. Dy: (334) 255-4246. Res: (334) 598-4351. EM: dionne@snowhill.com. S: Deanna. Dy: C Co, 1-212th Avn Regt, Fort Rucker, AL. Rtg: IP. RW Qual. Time: 2,200 Hrs./Cbt 49 AM/2.

**Dodd, Charles E.**, (CW2) (Charlie) Route 3, Box 236, Kempner, TX 76539. Dy: (254) 288-1412. Res: (254) 547-2655. EM: cdodd@vwm.com. S: Betina. Dy: A Co, 22nd Avn, Fort Hood, TX. Rtg: IP. RW Qual. Time: 1,000 Hrs.

**Dodd, Christopher**, (CW4) (Chris) Task Force Sabre, Opn. Joint Grd, Comanche, APO AE 09789. Dy: (318) 531-6784. EM: doddcs@aol.com. S: Lisa. Dy: O Troop, 4 Sqn, 2 AC, OH58D SIP. Rtg: SAA IFE SIP. RW Qual. RW Qual. Time: 4,000 Hrs. AM/2, IV.

**Dohmen, Richard D.**, (CW4) (Rick) 94-1169 Heahea Street, Waipahu, HI 96797. Res: (808) 680-0812. S: Sandy. Dy: US Army Student Detachment, Hawaii Pacific University. Rtg: SAA IFE SIP. RW Qual. Time: 3,000 Hrs. AM/1.

**Donahue, Kenneth A.**, (CW5) (Doc) 19 Gregg Way, Fort Rucker, AL 36362. Dy: (334) 255-2108. Res: (334) 598-8488. EM: kenneth\_donahue@rucker-emh4.army.mil. S: Camen. Dy: Asst TSM Longbow, Fort Rucker, AL. Rtg: MAA SIP. RW Qual. Time: 6,000 Hrs. DFC, AM/5, Life Member. Past Chapter Officer.

**Dotterer, Jack H.**, (CW5) (Jack) 627 Paddy Run Road, Clarksville, TN 37042. Dy: (502) 798-1841. Res: (615) 647-9076. EM: dotterer@soar.net. S: Pat. Dy: M1-60 Project Officer (SIMO). Rtg: MAA TP. RW Qual. Time: 6,500 Hrs./Cbt 1,066 AM/19.

**Doudna, Dean E.**, (CW4) (Pokeys) 3970 Drinkwater Street, Fort Irwin, CA 92310. Dy: (760) 254-5715. Res: (760) 386-2065. EM: doudna@junco.com. S: Diana. Dy: Cdr. Rtg: SIP. RW Qual. Time: 3,200 Hrs./Cbt 250



**AM7. Bronze Osm.**

**Dougherty, John R.**, (CW5) (John) 7640 Kingsbury Road, Alexandria, VA 22315. Dy: (301) 881-5040. Res: (703) 971-8033. EM: doughert@crosslink.net. S: Grace. Dy: Safety Officer, US Army Priority Air Transport Det, Andrews AFB, MD. Rtg: MAA ASO. RW Qual. FW Qual. Time: 5,700 Hrs/Cbt 800 AM/16.

**Dreeke, Dana A.**, (CW2) 82004-2 Lamar Avenue, Fort Hood, TX 76844-1513. Dy: (817) 288-3557. Res: (817) 539-9381. EM: uh-60@juno.com. S: Tracy. Dy: B Trp, 1-158th Avn Regt, 21st Cav, Fort Hood, TX. RW Qual. Time: 340 Hrs.

**Droz, Leanne R.**, (CW2) 6574 Brookshire Street, Fayetteville, NC 28314. Dy: (910) 396-0028. Res: (910) 867-3532. Dy: 57 Med Co, Fort Bragg, NC. RW Qual.

**Druley, Collis L.**, (WO1) 12 Kyle Way, Fort Rucker, AL 36362. S: Myra.

**Duffney, Robert J.**, (CW3) (Raptor) 101-B Brookview Drive, Ozark, AL 36360. S: Frances. Dy: AH-64 Pilot, B Co, 2-101, Fort Campbell, KY. Rtg: AA. RW Qual. Time: 1,500 Hrs/Cbt 30 AM/1.

**Durant, Michael J.**, (CW3/P) (Mike) 701 Norfolk Avenue, Clarksville, TN 37043. Dy: (502) 798-1817. Res: (931) 532-5813. EM: durantrm@soar.net. S: Lorie. Dy: 160th Special Operations Aviation Regiment, Fort Campbell, KY. Rtg: SIP. RW Qual. Time: 3,680 Hrs/Cbt 252 DFC/2 AM/3.

**Edwards, Jonathan R.**, (CW5) HNS 1st MI Bn (AE), CMR 430, Box 985, APO AE 09096. EM: argus22@msn.com. S: Rebecca. Dy: Standardization Officer, Wiesbaden, Germany. Rtg: IFE SIP MTP. RW Qual. FW Qual. Time: 7,700 Hrs. AM/1.

**Egnor, Jody L.**, (CW2) 3361 Backridge Road, Woodlawn, TN 37191. Dy: (502) 798-6949. Res: (931) 920-8830. EM: jognor@bellsouth.net. S: Janet. Dy: A Co, 101st, 7th Bat, Fort Campbell, KY.

**Eidem, Jon C.**, (CW2) P5C 42, Box 478, APO AA 34042. Res: (612) 888-8150. EM: eidemj@jfb-emh1.army.mil. Dy: B Co, 1-228th Avn Regt. Rtg: SAA. RW Qual. Time: 2,100 Hrs/Cbt 22.

**Elliot, Joseph P.**, (CW3) (Packman) 827 Keystone Drive, Clarksville, TN 37042-4723. Dy: (502) 798-4637. Res: (615) 431-6326. S: Anne. Dy: B Co, 9-101st Avn Bde, Fort Campbell, KY. Rtg: SAA MTP. RW Qual. Time: 2,200 Hrs. Life Member. Past Chapter Officer.

**Ellis, Michele L.**, (CW2) 4308 Teal Drive, Killeen, TX 76542. S: David. Dy: 507 Medical Co (Air Ambulance), Fort Hood, TX. RW Qual. Time: 375 Hrs.

**Ellison, Charles R.**, (CW2) (Chuck) 2206 Southport Lane, Killeen, TX 76542. Dy: (254) 288-9290. Res: (254) 524-9596. EM: ellisonc1@hood-emh3.army.mil. S: Colleen. Dy: 1 Det, C Co, 6-52nd Avn Regt, Bldg. 90049, Clarke Rd., Fort Hood, TX. RW Qual. FW Qual. Time: 2,600 Hrs.

**Elmore, Norman J.**, (CW4) (Elmo) 631 Sperry Loop, Wahiawa, HI 96786-4109. Dy: (808) 656-1011. Res: (808) 624-3633. EM: elmof47@aol.com. S: Lisa. Dy: B Co, 214

Avn Regt, Wheeler AAF, HI. Rtg: SIP IFE. RW Qual. Time: 3,300 Hrs.

**Emby, Jerry D.**, (CW3/P) P.O. Box 397, Wakarusa, KS 67487. S: Cassie.

**Erick, Robert S.**, (CW2) 501 W Cent. TX Expressway, Apt. 3805, Killeen, TX 76541. Dy: (254) 288-5544. Res: (254) 554-2505. RW Qual.

**Eshbaugh, Stephen D.**, (CW2) (Steve) 120 Elm St., Watertown, NY 13601. Dy: (315) 772-3817. Res: (315) 782-6974. EM: eshbaugh@giscon.net. Dy: A 1-10 AB, Fort Drum, NY. Rtg: AA ASO. RW Qual. Time: 700 Hrs.

**Estrella, Fernando M.**, (CW2) (Nando) 3361 Backridge Road, Woodlawn, TN 37191. Dy: (502) 798-2952. S: Prudence. Dy: B Co, 6-101 Avn Regt, Fort Campbell, KY. RW Qual. Time: 300 Hrs.

**Evans, Clifford J.**, (CW4) (C.J.) P.O. Box 1177, Wahiawa, HI 96786-1177. Dy: (808) 656-2548. Res: (808) 672-8115. EM: evanz@aloha.net. Dy: Bn Standards/Plt Ops Officer, 2/25 Avn Regt. Rtg: MAA IP. Rtg: RW Qual. Time: 3,300 Hrs/Cbt 36 AM/1. Life Member.

**Evans, Kenneth W.**, (WO1) (Ken) 3404 Granite Dr., Killeen, TX 76542-3635. Dy: (254) 288-9733. Res: (254) 554-3145. EM: kenandshari@juno.com. S: Shafr. Dy: C Co, 1-227 Avn, Fort Hood, TX. RW Qual. Time: 220 Hrs.

**Evans, William F.**, (WO1) 620 Whittie Hudson Road, Ozark, AL 36360-0080. Dy: (334) 255-3479. Res: (334) 774-7685. S: Daniela. Dy: B Co, 1-145th.

**Everett, Todd F.**, (CW2) 4072 Westmeadow Drive, Apt. 106, Colorado Springs, CO 80905. Dy: (719) 526-0223. Res: (719) 579-9665. EM: tever10623@aol.com. S: Lorinda. Dy: 571st Medevac Co, Fort Carson, CO. RW Qual. Time: 400 Hrs.

**Facciano, Claudio R.**, (CW4) (Claude) 734 Rutensnake Road, Harker Heights, TX 76548. Dy: (254) 288-3256. Res: (254) 698-6894. S: Adeline. Dy: Bn Stds Officer, Fort Hood, TX, 1-4 Avn Bn, 4ID. Rtg: SIP IFE. RW Qual. Time: 3,020 Hrs.

**Fagan, Jeffery G.**, (CW3) 17 Pineway Drive, Daleville, AL 36322. Dy: (334) 255-6225. EM: jfagan@snowhill.com. Dy: Maintenance Test Pilot Course, Fort Rucker, AL. Rtg: MTP ME IP. RW Qual. Time: 2,400 Hrs/Cbt 4 AM/1.

**Fancher, Howard H.**, (CW4) 6332A Noidan Place, Fort Polk, LA 71459. Dy: (318) 531-7030. Res: (318) 537-2638. S: Cathy. Dy: Squadron Standardization Instructor Pilot, 4/2 ACR. Rtg: MAA IFE SIP IP. RW Qual. FW Qual. Time: 7,800 Hrs. AM/2. Bronze Osm.

**Faragallah, John**, (CW2) (Juan) 4910 Joseph Dr., Killeen, TX 76542. Dy: (254) 288-9291. Res: (254) 634-1830. EM: uh0ip@central.net. S: Deborah. Dy: Fort Hood, TX. Rtg: IFE IP. RW Qual. Time: 1,700 Hrs.

**Farrow, Carl L.**, (CW3) HHT 6-6 Cav 11th Avn Regt, CMR 416, Box 623, APO AE 09140. EM: 106625,3542@compuserve.com. S: Allison. Dy: Sqdn Stds Officer, HHT, 6-6 Cav. Rtg: SAA IFE SIP. RW Qual. Time: 2,075 Hrs.

**Feltmate, Reid D.**, (CW5) Phantom Corps VP, OPS, 10865 FM 116, Gatesville, TX 76528. Dy: (254) 287-8338. Res: (254) 865-4271. EM: grisaigle@aol.com. S: Elizabeth. Dy: Installation Aviation Officer. Rtg: MAA SIP IE. RW Qual. Time: 6,700 Hrs/Cbt 1,650 AM/52. Vp, Special Operations, Phantom Corps Chapter. Past Chapter Officer.

**Ferguson, Richard F.**, (CW3) Route 1, Box 339, Ramer, AL 36069. Dy: (334) 255-6236. Res: (334) 584-9240. Dy: A Co, 1-223d Avn Regt, Fort Rucker. Rtg: ME IP. RW Qual. Time: 1,550 Hrs.

**Ferrell, Ronald J.**, (CW4) (Ron) 1021 Grande View Blvd., No. 227, Huntsville, AL 35824. Dy: (205) 313-4475. Res: (205) 772-6567. EM: ferrellr@comanche.redstone.army.mil. S: Kathie. Rtg: MAA SIP. RW Qual. Time: 3,500 Hrs.

**Fisher, Andy G.**, (WO1) 507 Briarwood Drive, Apt. 8A, Enterprise, AL 36330. Dy: (334) 308-9059. Res: (254) 690-1633. EM: fisher@nink.com. S: Jennifer. Dy: IERW Student Pilot, B Co, 1-145 Avn, Cbt 20 AM/2.

**Fix, John R.**, (CW4) P.O. Box 349, Cape Vincent, NY 13618-0349. Dy: (315) 772-3402. Res: (315) 654-4925. EM: alzs-av-ss@drum-pop.army.mil. S: Charlene M. Dy: Aviation Safety Officer, 10th Aviation Bde, Fort Drum, NY. Rtg: AA. RW Qual. Time: 3,200 Hrs. AM/1. Life Member.

**Flankey, Steven F.**, (CW4) 401 Deepwood Trail, Clarksville, TN 37042. Dy: (502) 798-1940. Res: (931) 551-9899. S: Laurie. Dy: Pilot, A Co, 1 Bn, 160th SOAR (A). Rtg: SAA IP. RW Qual. Time: 4,700 Hrs/Cbt 75 AM/2.

**Fletcher, Billy F.**, (CW4) 7338-B South Barker Cir, Fort Campbell, KY 42223. Dy: (502) 798-5125. Dy: Aviation Maintenance Officer, HHC, 8-101 Avn Regt, Fort Campbell, KY. Rtg: MAA IP MTP MTFE. RW Qual. Time: 8,896 Hrs.

**Flick, Todd M.**, (WO1) 71 Am Windham Drive, No. 207 Old Town Square, Daleville, AL 36322. Res: (334) 598-6594. RW Qual. FW Qual.

**Fortune, Thomas H.**, (CW4) (HB) 78th Avn Bn, Box 86, Unit 45007, APO AP 96338-5007. EM: fortunet@zamu.atlnet.or.jp. S: Cynthia. Dy: Fixed Wing Detachment ASO, Camp Zama, Japan. Rtg: SAA IP ASO. RW Qual. FW Qual. Time: 3,100 Hrs.

**Foster, Scott D.**, (WO1) 802 Green Drive, Enterprise, AL 36330. Dy: (334) 393-6462. Res: (334) 393-6462. S: Lisa. Dy: Student Pilot.

**Fraher, Jeffrey R.**, (CW2/P) 6010 Heath Court, Colorado Springs, CO 80922. Res: (719) 574-8273. EM: jrfraher@brain.uccs.edu. S: Tammie. Dy: USASD. Rtg: SAA IP. RW Qual. FW Qual. Time: 2,000 Hrs. AM/2.1V.

**Free, Reginald M.**, (CW2) (Reg) 3707-B Collier St., Wahiawa, HI 96786-4752. Dy: (808) 656-1379. Res: (808) 624-2173. EM: threes@aol.com. S: Jeannette. Dy: Pilot, B Troop, 34 Cav, 25th ID. RW Qual. Time: 386 Hrs.

**Freeze, Jason Y.**, (CW2) 1403-A Indiana

Avenue, Fort Campbell, KY 42223. Dy: (502) 798-2700. Res: (931) 431-6215. S: Marjorie. Dy: C 1-101st Avn, Fort Campbell, KY. RW Qual. Time: 350 Hrs.

**Frey, Andrew R.**, (CW2) (Drew) 938 Emjay Way, Apt. D, Carthage, NY 13619. Dy: (319) 772-9373. Res: (315) 493-9689. S: Bonnie. Dy: A Co, 2-10 Assault Helicopter Battalion, Fort Drum, NY. Rtg: AA. RW Qual. Time: 975 Hrs.

**Frye, Jerry W.**, (CW3) (Odie) 5856 Corner Oaks Drive, Hope Mills, NC 28348. Dy: (910) 396-7478. EM: froepoh@aol.com. S: Lynne. Dy: Aviation Safety Officer, A Co, 1-229th ATKHB (Abn), Fort Bragg, NC. Rtg: SAA. RW Qual. Time: 1,450 Hrs.

**Fugate, Gary L.**, (CW2) CMR 414, Box 542, APO AE 09173. EM: fugateg@email.hohenfels.army.mil. S: Fatima. Dy: UH-1 Pilot, CMTC Avn Det, UH-1, UH-60, Hohenfels, Germany. Rtg: AA. RW Qual. Time: 1,200 Hrs.

**Fusco, Frank A.**, (CW2) (Joey) 859 Fredonia Drive, Fayetteville, NC 28311. Dy: (910) 396-9070. Res: (910) 630-1188. S: Lisa. Dy: UH-60L Line Pilot, A Co, 2-82nd Avn. RW Qual. Time: 625 Hrs.

**Gadomski, Thomas P.**, (CW5) (Tom) North County VP Memb., 9933-A Saratoga Road, Fort Drum, NY 13603-3048. Dy: (315) 772-3264. Res: (315) 773-0194. EM: lgadomski@glscio.net. S: Connie. Dy: Tactical Operations Officer, 10th Avn Bde, Fort Drum. Rtg: MAA. RW Qual. Time: 4,000 Hrs. Vp, Membership Enrollment, North County Chapter. Past Chapter Officer.

**Gartman, William R.**, (CW4) (Bill) 78 Erdl Avenue, Fort Rucker, AL 36362. Res: (334) 255-3387. Dy: Warrant Officer Career Center, Fort Rucker, AL.

**Gaudette, Eric J.**, (WO1) 5723 Five Sisters Court, Fayetteville, NC 28311. Res: (910) 823-2254. S: Ami. Dy: C Trp, 1-17 Cav. Gehrtes, Shawn E. (WO1) C Trp, 2/6 Cav, CMR 416, Box 214, APO AE 09140. Res: (334) 503-9776. EM: sgehrtes@malexcoite.com. S: Sylvia. Dy: Pilot. RW Qual.

**Genier, Keith D.**, (CW3) 109 Oakview Circle, Enterprise, AL 36330-1589. Dy: (334) 255-4244. Res: (334) 393-8866. S: Kerstin. Dy: C Company, 1-212th Avn Bn, Fort Rucker, AL. Rtg: IP ASO. RW Qual. Time: 2,000 Hrs./Cbt 150 AM/1.

**Gere, Duane A.**, (CW3) B Co, 2-1 Avn Regt, CMR 454, Box 2328, APO AE 09250. S: Nancy. Dy: Avn Safety Officer, Katterbach. Rtg: SAA. RW Qual. Time: 2,500 Hrs./Cbt 50 AM/2.

**Gibson, David T.**, (CW3) (Tomy) 277 Kinlaw Road, Fayetteville, NC 28311. Dy: (910) 396-7349. Res: (910) 630-3425. S: Suzanne. Dy: A Co, 1/82nd Avn Bde, Fort Bragg, NC. Rtg: SAA SIP. RW Qual. Time: 1,900 Hrs./Cbt 50 AM/1.

**Giganti, Raymond G.**, (CW3) (Nick) Phantom Corps Cpt Vp Plt, 903 Mallow Circle, Killeen, TX 76542. Dy: (254) 288-5144. Res: (254) 628-7810. Dy: B Troop, 1/158 Avn Regt, 21st Cav, Fort Hood, TX 76544. Rtg: SAA SIP ASO MTP. RW Qual. Time: 4,100 Hrs. Vp, Publicity, Phantom

#### Corps Chapter

**Gilliland, Clifford R.**, (CW2) 1047-1 Nysteen Street, Fort Wainwright, AK 99703. Dy: (907) 353-7008. Res: (907) 356-1218. EM: cw2@hotmail.com. S: Barbara. Dy: Pilot. Rtg: AA. RW Qual. Time: 2,200 Hrs.

**Gillogly, Richard S.**, (CW3) (Gill) 4059 A Daisy Mine Court, Fort Irwin, CA 92510-2006. Dy: (760) 380-5907. Res: (760) 386-2922. EM: rkgillogly@mscormm.com. S: Theresa. Dy: HHD, NTC Spt Bn, Fort Irwin, CA. RW Qual. Time: 1,625 Hrs. Life Member.

**Gilpin, Sean F.**, (CW3) 1470 Dr. Meade Lane, Clarksville, TN 37042. Dy: (502) 798-2700. Res: (615) 572-0957. EM: smgilpin@knightswave.com. S: Martha. Dy: AH-64 SIP, C Company, 1-101st Avn, Fort Campbell, KY. Rtg: IFE IP. RW Qual. Time: 2,200 Hrs./Cbt 50 AM/1.

**Gjertson, Douglas W.**, (CW5) 1908 Antelope Trail, Harker Heights, TX 76648. Dy: (254) 288-6231. Res: (254) 695-1556. EM: gjertson@hood-emh3.army.mil. S: Susan. Dy: HHS, 15th Mi Bn (AE), Fort Hood, TX. Rtg: SAA SIP. RW Qual. Time: 5,200 Hrs./Cbt 1,013 DFC/1, AM/36.

**Gladden, Jeffrey L.**, (WO1) 29 E. Harris Drive, Fort Rucker, AL 36362. Dy: (334) 255-7079. Res: (334) 598-1216. S: Jennifer. Dy: AQC, CH-47D, Fort Rucker, AL. RW Qual. Time: 150 Hrs.

**Godfrey, Allen R.**, (CW3) (Randy) 706 Crimston Court, Dothan, AL 36303. Dy: (334) 255-5051. Res: (334) 794-9799. S: Deborah. Dy: OH-58D(i) Instructor Pilot, C Co, 1-14th Avn Rgt, Fort Rucker, AL. Rtg: SAA IP. RW Qual. Time: 2,000 Hrs.

**Goetz, Steven C.**, (CW5) (Steve) 1037 B Seminole Road, Fort Campbell, KY 42223. Dy: (502) 798-2029. S: Charli. Rtg: MAA IFE SIP. RW Qual. Time: 4,400 Hrs./Cbt 100 AM/1.

**Goforth, William S.**, (CW4) 110 Edinburgh Court, Richmond Hill, GA 31324. Dy: (912) 352-8839. S: Michaela. Dy: Battalion Avn Maintenance Oic, Hunter AAF, GA, 1-3 Avn. Rtg: MTP. RW Qual. Time: 2,000 Hrs./Cbt 25 AM/2.

**Gonzalez, Angel**, (CW3) P.O. Box 332, Fort Campbell, KY 42223-0332. Dy: (502) 798-1924. Res: (931) 647-2653. EM: gonzalez@scar.net. S: Gayle. Dy: PC Officer, B 4-160th SOAR (A).

**Graf, Roger A.**, (CW2) (Cochise) 403 Fairfield Drive, Enterprise, AL 36330. Dy: (334) 255-5058. Res: (334) 393-8013. S: Cheryl. Dy: AH-64 Instructor Pilot, Fort Rucker. Rtg: IP. RW Qual. Time: 1,500 Hrs.

**Graham, Timothy P.**, (CW2) 1526 Inchon, Banstow, CA 92311. Dy: (619) 254-2970. Res: (760) 252-1091. EM: tgraham@dvs-dghsc.com. S: Laura. Dy: NTC Aviation Co (AASLT), Fort Irwin, CA. Rtg: AA. RW Qual. Time: 400 Hrs.

**Grass, Dorothy A.**, (WO1) (Anne) 1705 Thistlewood, Clarksville, TN 37042. Res: (617) 906-8989. S: Christian. Dy: A-2/17 Cav, Fort Campbell, KY.

**Greiner, John P.**, (WO1) 3157 Achey Drive, Enterprise, AL 36330. Dy: (334) 255-9730. Res: (334) 308-1064. Dy: B Co, 1/145th Avn

RW Qual. Time: 80 Hrs.

**Griffin III, Harold W.**, (CW2) (Griff) CMR 477, Box 1319, APO AE 09165. EM: 10656.622@compuserve.com. S: Brigitte. Dy: A 2/501 Avn Regtment, Hanau, Germany. RW Qual. Time: 1,050 Hrs.

**Grooms, Clay M.**, (WO1) 191 Lakewood Drive, Daleville, AL 36322. Dy: (334) 255-9941. Res: (334) 598-2819. S: Menda. Dy: Student Aviator, Fort Rucker, AL.

**Grubbs, Larin D.**, (WO1) 35 Gall Lane, Fort Rucker, AL 36362. Dy: (334) 255-9023. Res: (334) 598-5219. EM: igrubbs@snowhill.com. S: Julie. Time: 100 Hrs.

**Gruner, Kurt M.**, (CW2) A Co., 1-501 Avn., CMR 477, Box 735, APO AE 09165. EM: kurtgru@hotmail.com. Dy: AH-64 Pilot in command. RW Qual. Time: 671 Hrs.

**Guido, David E.**, (CW3) 175 Greenbriar Court, Savannah, GA 31419. Dy: (912) 352-8844. Res: (912) 927-0492. EM: coperdr06@aol.com. S: Pamela. Dy: Pilot, D Co, 2/3 Avn. Rtg: MTFE. RW Qual. Time: 1,800 Hrs./Cbt 100 AM/1.

**Guid, Jay M.**, (CW4) CASSID, CMR 477, Box 536, APO AE 09165. EM: guidj@gmail.com. S: Lena. Dy: USAFEUR UH-60 Maint Test Flight Evaluator, Hanau, Germany. Rtg: MTP. RW Qual. Time: 3,000 Hrs./Cbt 150 AM/2.

**Guthrie, David T. II**, (CW4) 1322 N. Racine Circle, Mesa, AZ 85205. Dy: (602) 891-3537. EM: dguthrie@phxao.cdmdw.dia.mil. Dy: Acceptance Pilot/GFL.

**Hass, Willis J.**, (CW4) (Jamie) 30 Red Cloud Road, Fort Rucker, AL 36362. Dy: (334) 255-5033. EM: jamie\_hass@rucker-emh4.army.mil. S: Debra. Dy: OH58D Kiowa Warrior SIP/Platoon Leader, C Co, 1-14th Avn. Rtg: IP SIP. RW Qual. Time: 4,900 Hrs.

**Habermehl, James L.**, (CW3) (Hab) 3473 Thomdike Drive, Fayetteville, NC 28311-2515. Dy: (910) 396-1066. Res: (910) 482-3430. EM: habemej@bragg.army.mil. S: Christy. Dy: HHC 18th Avn Bde, Fort Bragg, NC, Brigade AMO. Rtg: MTP. RW Qual. Time: 1,650 Hrs.

**Haeme, John D.**, (CW2) (Buster) 5584 Carter Street, No. 2, Fort Hood, TX 76544-8807. Dy: (254) 287-7985. Res: (254) 539-2953. S: Rhonda. Dy: AH-64A Pilot, C Co, 1-4 Avn, Fort Hood, TX. RW Qual. RW Qual. Time: 550 Hrs.

**Hagenbrock, Scott L.**, (WO1) 307 Candlebrook Drive, Enterprise, AL 36330. Dy: (334) 255-9730. Res: (334) 393-3286. S: Sharna. Dy: 3rd ACR, E-60, Fort Carson, CO. RW Qual. RW Qual. Time: 1,240 Hrs.

**Hall, Ryker B.**, (WO1) 13 Hartell Way, Fort Rucker, AL 36362. Dy: (334) 598-2292. Res: (334) 598-2292. Dy: Student Pilot. RW Qual. Time: 100 Hrs.

**Hallmark, Edmond E.**, (CW3) (Ed) 111 Mohawk Street, Enterprise, AL 36330. Dy: (334) 255-5058. Res: (334) 393-4501. Dy: AH-64 IP, D Co, 1-14th Avn Regt. Rtg: SAA IP. RW Qual. Time: 1,500 Hrs./Cbt 134 AM/1.

**Hammel, Paul D.**, (CW3) (Paul) 4905 Climbing Vine Place, Marietta, GA 30066. Dy: (334) 255-9659. Res: (334) 598-4771. EM: paul\_hammel@rucker-emh4.army.mil. S: Catherine. Dy: UH-60 Safety Officer,

Written Instructor, DOTDS. Rtg: IP ASO. RW Qual. Time: 3,500 Hrs.

**Hammerschlag, Fred J.,** (CW4) 751 Higgins Road, No. 15, Banstow, CA 92311. Dy: (619) 254-3083. Res: (619) 252-8689. Dy: MTP Evaluator. NTC Avn Co. Fort Irwin. Harper, Timothy W., (CW3) (Bart) 1761 Chalybeate Springs, Angier, NC 27501. Dy: (910) 396-4752. Res: (919) 369-3295. Dy: AH64 IP, Bn Master Gunner, 3-229 Avn Regt. Rtg: SAA. SIP. RW Qual. Time: 2,200 Hrs./Cbt 10 AM2.

**Harrington, Kent H.,** (CW4) 150 North Main Street, Black River, NY 13612. Dy: (315) 772-5853. Res: (315) 773-0934. EM: kenharf@aol.com. S: Marta. Dy: Bn SIP, 2-10 Avn Regt. Fort Drum, NY. Rtg: MAA SIP IFE IP. RW Qual. Time: 4,600 Hrs.

**Harris, Curtis,** (CW2) (Rudy) 1748 Butternut Dr., Clarksville, TN 37042. Dy: (502) 798-5215. Res: (615) 645-2446. EM: charis282@aol.com. Dy: D Tnp, 2/17 Air Cav. Rtg: MTP. RW Qual. FW Qual. Time: 1,000 Hrs.

**Harris, Jeffrey W.,** (CW3) (Jef) A Co, 127H ASL, CMR 477, Box 83, APO AE 09165. S: Marilyn. Dy: Hanau, Germany. Rtg: MAA ASO. RW Qual. Time: 2,900 Hrs./Cbt 93 AM1.

**Harsh, Terence A.,** (CW2) (Terry) 131 Spring Avenue, Watertown, NY 13601. Dy: (315) 772-3810. Res: (315) 772-3817. EM: harsh@disco.net. S: Nancy. Dy: Fort Drum, NY. RW Qual. Time: 600 Hrs.

**Hartley, Don,** (CW2) (Don) 26 Prospect Street, S. Dartmouth, MA 02748. Dy: (508) 990-2460. Res: (508) 364-1069. EM: donald\_hartley@ml.com. Dy: Financial Consultant, Merrill Lynch. Rtg: IP. RW Qual. Time: 3,000 Hrs. Past Chapter Officer.

**Hartwell, Stuart G.,** (CW2) (Stu) 935 Tommy Oliver Road, Clarksville, TN 37042. Res: (931) 906-5434. EM: stuh22@aol.com. S: Lenore. Dy: MTFE, B Co, 6-101st Avn Regt. Rtg: AA MTP. RW Qual. Time: 1,400 Hrs.

**Hartwick, Michael L.,** (WO1) (Harv) 11 Kyle, Fort Rucker, AL 36362. Dy: (334) 255-9023. Res: (334) 598-5940. EM: mkhart@snowhill.com. S: Kent. Dy: Flight Student.

**Haubrich, Bradley S.,** (WO1) (Brad) 14 Galt Lane, Fort Rucker, AL 36362-5000. Dy: (334) 255-9960. Res: (334) 503-9457. EM: haubrich@snowhill.com. S: Georganne. Dy: IERW Flight Training, B Co, 1-145th, Fort Rucker, AL. Time: 500 Hrs.

**Hawkins, Robert J.,** (CW5) (Bob) P.O. Box 752, Copperas Cove, TX 76522. Dy: (254) 288-1974. Res: (254) 547-9899. S: Carol. Dy: 15th MI Bn, Fort Hood, TX. Rtg: MAA IFE SIP. RW Qual. FW Qual. Time: 9,430 Hrs./Cbt 1,130 Past Chapter Officer.

**Hayer, David W.,** (CW3) 3621-B Porter Loop, Wahiawa, HI 96786. Dy: (808) 606-0480. Res: (808) 624-5492. Rtg: SAA IP IFE. RW Qual. Time: 2,100 Hrs.

**Hazelton, Frank B.,** (CW2) 268 Cheshire Road, Clarksville, TN 37043. Res: (931) 551-9620. S: Kim. Dy: 160th SOAR (A), Fort Campbell, KY. Rtg: SAA. RW Qual. Time: 1,600 Hrs.

**Heath, Richard G.,** (CW2) (Rick) 1819 Rivergate Road, Fayetteville, NC 28304. Dy:

(910) 396-3789. Res: (910) 423-7347. EM: heater@foto.inf.net. S: Kelliagh. Dy: C 1/17th Cav, Fort Bragg, NC. RW Qual. Time: 300 Hrs.

**Helmbach, Douglas A.,** (CW2) 304 Northridge Drive, Clarksville, TN 37042. Dy: (502) 798-1799. EM: helmrackd@juno.com. S: Leslie. Dy: MH-47E Line Pilot, A Co, 2nd Bn, 160th SOAR, Fort Campbell, KY. Rtg: AA. RW Qual. Time: 800 Hrs.

**Hendershot, George B.,** (CW4) (Fog) 1907 Standridge Street, Killeen, TX 76543-3367. Dy: (254) 287-7757. Res: (254) 286-8833. EM: hendershog@hood-emh3.army.mil. S: Barbara. Dy: HHT 21st Cav Bde (AC), Fort Hood, TX. Rtg: SIP. RW Qual. Time: 6,350 Hrs./Cbt 1,128 AM25.

**Henry, Ronald L.,** (CW3) (Ron) 109 Pratt Drive, Enterprise, AL 36330. Dy: (334) 255-5716. Res: (334) 393-4931. S: Gwendolyn. Dy: CH-47D Standardization Pilot, Fort Rucker, AL. Rtg: AA IFE SIP. RW Qual. Time: 2,600 Hrs./Cbt 48 AM1.

**Hernandez, John R.,** (CW2) 3444-D McCormack Rd, Wahiawa, HI 96786. Dy: (808) 656-1188. EM: jherman@juno.com. S: Neysa. Dy: A Co, 2-25th Avn, Maintenance Test Pilot. Rtg: MTP. RW Qual. Time: 1,100 Hrs.

**Hewitt, James C.,** (CW2) 1368 Sherman Street, Watertown, NY 13601. Dy: (315) 782-6608. Res: (315) 782-0605. Rtg: AA IP. RW Qual. FW Qual. Time: 3,700 Hrs./Cbt 1,000 DFC, AM37.

**Hielsberg, Heath A.,** (CW2) (Heater) A Co, 1-2 Avn, Unit 15008, Box 170, APO AP 96208. EM: heater64@hotmail.com. Dy: AH-64 Pilot, 1-2 Avn Regt, Camp Page, Korea. RW Qual. Time: 250 Hrs.

**Hill, Joshua S.,** (WO1) (Josh) 711 A.M. Windham Drive, No. 300, Daleville, AL 36322. Dy: (334) 255-9960. Res: (334) 598-5277. S: Stephanie. Dy: Aviator Student, B Co, 1/145th Avn.

**Hill, Robert D.,** (CW5) (Bob) 6917 Candlewood Drive, Fayetteville, NC 28314-1605. Dy: (910) 396-4208. Res: (910) 864-8908. S: Lei. Dy: XVIII Corps Standardization. Rtg: MAA IFE SIP. RW Qual. Time: 8,200 Hrs./Cbt 1,200

**Hillyer, John A.,** (CW3) P.O. Box 57085, North Pole, AK 99705-2085. Dy: (907) 353-6861. Res: (907) 489-7012. S: Leslie. Dy: D Co, 4-123rd Avn Regt, Fort Wainwright, AK. Rtg: SAA IP IE. RW Qual. Time: 3,000 Hrs.

**Hinchman, William F.,** (CW3) (Sonny) 903 Mallow Circle, Killeen, TX 76542. Dy: (817) 288-0561. Res: (817) 628-1879. Dy: IP/MTP, E Co, 1-7 Cav. Rtg: IP MTP. RW Qual. Time: 2,400 Hrs.

**Hoke, Charles S.,** (CW2) P.O. Box 620655, Fort Rucker, AL 36362-0655. Dy: (334) 255-1355. Res: (334) 598-2011. S: Heidi. Dy: C Co, 1-13, Fort Rucker, AL.

**Holland, Donald E.,** (CW3) 3503 Clearwater Drive, Clarksville, TN 37042. Dy: (502) 798-4336. EM: mlp64@aol.com. S: Winifred. Dy: MTP, C Co, 8-101st, Fort Campbell, KY. Rtg: MTP. RW Qual. Time: 2,300 Hrs.

**Homer, Terry L.,** (CW2) (LJ) 12 Avellino

Flood, Fort Bragg, NC 28307. Res: (910) 436-1979. EM: lahomer@juno.com. S: Amy. Dy: C Troop, 1/17 Cav, Fort Bragg, NC. RW Qual. Time: 400 Hrs.

**Hosley, Allen R.,** (CW3) 168 Timberlake Drive, Hendersonville, TN 37075. Dy: (502) 798-6462. Dy: Standardization Instructor Pilot. Rtg: SAA IP. RW Qual. FW Qual. Time: 3,500 Hrs./Cbt 210 AM3.

**Howard, David Jon,** (CW4) P.O. Box 620425, Fort Rucker, AL 36362-0425. Rtg: MAA TP IP. Life Member.

**Howard, Jacob M.,** (CW4) (Jake) 206 3rd Street, No. A, Honolulu, HI 96818-4908. Dy: (808) 449-0905. Res: (808) 449-0330. EM: jakecindy@aol.com. S: Cindy. Dy: Hawaii Regional Flight Center, Hickam AFB, HI. Rtg: MAA IFE SIP XP. RW Qual. FW Qual. Time: 5,300 Hrs.

**Howdeshell, Mark A.,** (CW2) 104 E. Luzon Drive, Fort Bragg, NC 28307-5000. Dy: (910) 907-2047. Res: (910) 426-3678. EM: howdeshell@bragg.army.mil. S: Jo. Dy: 57th Medical Company (AA), Fort Bragg, NC. Time: 1,000 Hrs./Cbt 150 AM1.

**Hunter, Donald J.,** (CW2) OMC/AV Apache TAFT, Unit 64901, Box 18, APO AE 09639-4901. EM: dhunter14@aol.com. Dy: AH64 Maintenance Test Pilot Advisor for Egyptian Air Force. Rtg: AA MTP. RW Qual. FW Qual. Time: 1,200 Hrs./Cbt 22 AM2.

**Hurley, Mark S.,** (WO1) 6320-B Noidan Street, Fort Polk, LA 71459. Dy: (318) 531-7068. Res: (318) 537-8765. EM: msurhury@bigfoot.com. S: Donna. Dy: 2nd ACR, Fort Polk, LA. RW Qual. Time: 180 Hrs.

**Huseby, Dana S.,** (CW2) 724 Ridgewood Drive, Manhattan, KS 66502. Dy: (913) 239-5642. Res: (913) 537-4650. EM: dshuse@aol.com. Dy: 82nd Medical Company, Fort Riley. RW Qual. FW Qual. Time: 900 Hrs.

**Hutchens, James N.,** (CW4) (Hutch) 1030 N. Silver Ash, Boise, ID 83713. Dy: (208) 389-5064. Res: (208) 376-5753. EM: hutch@aol.com. S: Kim. Dy: Standardization Instructor Pilot, AASF, IDARNG. Rtg: SIP. RW Qual. Time: 5,650 Hrs.

**Hutson, Michael J.,** (CW5) (Mike) 400 Boscomb Dr., Clarksville, TN 37040. Dy: (502) 798-2029. Res: (931) 552-5385. S: Janie. Dy: Installation Flight Standards Officer, Fort Campbell. Rtg: MAA IFE SIP. RW Qual. Time: 7,800 Hrs./Cbt 1,001 DFC1, AM36.

**Hyatt, Jr., Jeffrey F.,** (CW2) 1511-A Werner Avenue, Fort Campbell, KY 42223. Dy: (502) 798-2746. EM: jhyattjr@aol.com. S: Courtney. Dy: UH-60 Pilot, A Co, 9-101st Avn Regt, 101st Avn Div (AASLT). RW Qual. Time: 400 Hrs.

**Ilg, Mark W.,** (CW2) P.O. Box 35284, Fort Wainwright, AK 99703. Dy: (907) 353-9835. Res: (907) 452-6275. EM: markilg@potanet.com. Dy: Battalion Safety Officer, 4-123rd Avn Regt, Fort Wainwright, AK. Rtg: ASO. RW Qual. Time: 1,100 Hrs. Life Member.

**Ivey, Mark B.,** (CW3) 616 N Williamsburg Road, Savannah, GA 31149. Dy: (912) 352-6036. Res: (912) 925-7770. S: Mary Beth. Dy: B Co, 1-3th Avn Regt. Rtg: SAA IP. RW Qual. Time: 1,700 Hrs./Cbt 50 AM3.

**Jaszczak, Charles**, (WO1) 215 N. Gladys Street, Apt. 305, Leesville, LA 71446. Dy: R Troop, 2nd ACR, Fort Polk, LA. RW Qual. Time: 1,800 Hrs.

**Jewett, Michael R.**, (CW2) PSC 01, Box 2635, APO AA 34001. EM: mjewett@pananet.com. S: Tawnee, Dy: Panama Regional Flight Center, Howard AFB, Panama. Flt: ASO. RW Qual. FW Qual. Time: 1,800 Hrs.

**Johnson, Arthur L.**, (CW3) (AR1) 18211 87th Avenue East, Puyallup, WA 98375. Dy: (253) 967-4769. Res: (253) 846-7101. EM: arlj@ix.netcom.com. S: Ronda. Dy: 2nd Flt, B Co, 214th Aviation Regiment, Fort Lewis, WA. Flt: SAA. IP. RW Qual. Time: 1,650 Hrs.

**Johnson, Richard G.**, (CW5) (R1ck) 120 Leslie Lane, Yorktown, VA 23093. Dy: (757) 878-5479. Res: (757) 867-7648. EM: rjohnson@eussis-aaltds1.army.mil. S: Barbara. Dy: Aviation Applied Technology Div, Fort Eustis, VA. Flt: MAA SIP IP TP MTP. RW Qual. FW Qual. Time: 6,600 Hrs./Cbt 1,865 Life Member.

**Johnson, Robert S.**, (CW5) (Scotly) 409 Janice Street, Enterprise, AL 36330. Dy: (334) 255-3000. Res: (334) 393-2984. EM: robert\_johnson@rucker-emh4.army.mil. S: Dawn. Dy: Aviation Branch Safety Office. Flt: SIP ASO. RW Qual. FW Qual. Time: 5,200 Hrs./Cbt 125 AM/1.

**Johnson, Steven E.**, (CW3) 1225 West Monte, Mesa, AZ 85202. Dy: (602) 891-3822. Res: (602) 730-8965. S: Mary. Flt: IP MTP. RW Qual. Time: 1,400 Hrs.

**Jones, James F.**, (CW3) (Jlm) HHD, 7/159th Avn Regt, CMR 416, Box 1735, APO AE 09140. EM: jonesj@email.anisbach.army.mil. S: Gina. Dy: Avn Safety Officer, Ilesheim, Germany. Flt: SAA. RW Qual. Time: 1,600 Hrs.

**Jones, Randolph W.**, (CW5) (Randy) 73396 Gardner Hills, Fort Campbell, KY 42223. Dy: (502) 798-0174. Res: (931) 431-6399. EM: jones@soar.net. S: Wendt. Dy: Standardization Officer, HHC, 160th SOAR (A), RW Qual. FW Qual. Time: 9,000 Hrs./Cbt 1,200 DFC/1, AM/43, NEB, 92 Aviator Of Year.

**Jones, Robert E.**, (CW3) 15 Irwin Street, Fort Rucker, AL 36362. Dy: (334) 256-8562. Res: (334) 598-1777. S: Marcia. Dy: UH-60 IP, C Co, 1-223rd Flt: SAA. IP. RW Qual. Time: 1,875 Hrs./Cbt 79 AM/2.

**Jones, William R.**, (WO1) (Bill) 21 Ames Lane, Fort Rucker, AL 36362. Res: (334) 598-2739. EM: jonesb@snowhill.com. S: Diana. Dy: Aviation Student. RW Qual. Time: 140 Hrs.

**Jordan, Kevin W.**, (CW2) 30 Ripley Drive, Redstone Arsenal, AL 35808-1113. Dy: (205) 876-6036. Res: (205) 430-2789. EM: jordankw@aol.com. S: Kimberly. Dy: Maintenance Officer, Redstone Arsenal Airfield. RW Qual. Time: 465 Hrs. AM/1.

**Joseph, Brian J.**, (CW2) 46 Woodfield Place, Enterprise, AL 36330. Res: (334) 308-1052. EM: bjoz@ata.net. Dy: UH60 Instructor Pilot, Fort Rucker, AL. Flt: IP. RW Qual. Time: 1,350 Hrs.

**Kalahan, James C.**, (CW4) (Griz) 1433 Southern Drive, Enterprise, AL 36330. Dy: (334) 255-5033. Res: (334) 347-0199. EM:

jdkai@aol.com. S: Diana. Dy: OH-58D Kiowa Warrior SIP, C Co, 1-14 Avn Regt. Flt: MAA. SIP. RW Qual. Time: 4,700 Hrs./Cbt 50 AM/2, 91 Aviator Of Year.

**Kalorigis, Peter R.**, (CW5) (Pete) 5th Avn Regt, RTA, RAAF Townsville, APO AP 96554. EM: cw5peterkalorigis@usa.net. S: Sharon. Dy: Army Exchange Officer, 5th Avn Regt, Australia. Flt: MAA IFE SIP IP MTP. RW Qual. Time: 8,500 Hrs./Cbt 1,550 DFC/1, AM/19.

**Kaufman, Matthew D.**, (WO1) P.O. Box 83, Fort Campbell, KY 42223-0083. Dy: (502) 798-5947. Res: (615) 920-8634. S: Traci. Dy: Line Pilot, A-4-101. RW Qual. Time: 550 Hrs.

**Keiffer, Robert P.**, (CW3) D Troop, 1-4 Cav, CMR 464, Box 771, APO AE 09226. EM: rkeiffer@sw.cybersurf.de. Dy: OH 52D IP. Flt: IP. RW Qual. Time: 2,200 Hrs./Cbt 50 AM/1.

**Kelly, William M.**, (CW3(P)) (Mike) 213 W. Kingswood Drive, Enterprise, AL 36330. Res: (334) 393-2857. S: Quincy. Dy: OH-58 IP, E Co, 1-212 Avn. Flt: SAA. SIP. RW Qual. Time: 4,000 Hrs.

**Kelso, Mark G.**, (CW2) 115 Country Walk Circle, Savannah, GA 31419. Dy: (912) 352-6497. Res: (912) 927-6398. EM: yooed@aol.com. Dy: Pilot, B Co, 3/160th SOAR (A). Flt: AA. RW Qual. Time: 1,700 Hrs.

**Kendil, Christopher**, (CW2) 26752 Anabel Avenue, Evans Mills, NY 13637. Dy: (315) 772-3842. Res: (315) 829-8347. EM: 74717.263@compuserve.com. S: Trinna. Dy: C Co, 1-10 Avn Regt, Fort Drum, NY. RW Qual. Time: 1,200 Hrs.

**Kennedy, James P.**, (CW2) (Jim) Aviation Center VP Progr., 104 Mamie Street, Enterprise, AL 36330. Dy: (334) 255-3411. Res: (334) 393-2379. S: Nina. Dy: OH-58D Kiowa Warrior IP. Flt: SAA. IP. RW Qual. Time: 2,000 Hrs./Cbt 100 Life Member. Vp. Programs, Aviation Center Chapter. Past Chapter Officer.

**Kennedy, Stanley A.**, (CW4) (Stan) 1824 Dotsenville, Clarksville, TN 37042. Dy: (502) 798-1131. Res: (931) 647-3135. EM: fmj79a@prodigy.com. S: Karen. Dy: OH6/AH6/MH6 SIP/IFE/SOATC 160th SOAR, Fort Campbell, Flt: MAA SIP IFE MTP. RW Qual. Time: 5,600 Hrs./Cbt 25 AM/1.

**Kenny, David A.**, (CW3) 269 Barlotti Road, Sackets Harbor, NY 13685. Dy: (315) 772-5853. Res: (315) 646-6790. EM: dkenny@imconet.net. S: Susan. Dy: 2-10 Avn Regt SIP, Fort Drum, NY. Flt: MAA SIP. RW Qual. Time: 4,200 Hrs.

**Kenny, Michael P.**, (CW4) (Smoothie) 332 Jonaquin Circle, Hopkinsville, KY 42240. Dy: (502) 798-1790. S: Marcia. Dy: MH-47E SIP, A Co, 2/160 SOAR(A). Flt: MAA IFE SIP. RW Qual. Time: 4,200 Hrs.

**Keough, Bradley R.**, (CW3) (Brad) 914 Erwin Court, Fort Wainwright, AK 99703. Dy: (907) 353-7072. Res: (907) 356-1939. S: Rebecca. Dy: CH47D Instructor/Examiner, B Co, 4/123rd Avn. Flt: SAA IP IFE. RW Qual. Time: 1,700 Hrs.

**Khelemsky, Vitaly**, (CW3) (Vito) A Co, 2-52

Avn. Regt., Unit #15210, APO AP 96271-0146. Dy: IP. Camp Humphreys, Korea. Flt: SAA IP. RW Qual. Time: 2,700 Hrs./Cbt 102 Life Member.

**Kinneer, Todd C.**, (CW2) 2784 Union Hall Road, Clarksville, TN 37042. Dy: (502) 798-2350. Res: (615) 572-3273. S: Misty. Dy: A Troop, 2-17 Cav, Fort Campbell, KY. Flt: MTP. RW Qual. Time: 700 Hrs.

**Kirchgessner, Timothy J.**, (CW2) 1521 Ohio Avenue, No. B, Fort Campbell, KY 42223-3505. EM: kirchgess@aol.com. S: Kris Anna. Flt: MTP. RW Qual. Time: 1,100 Hrs.

**Kiser, Richard F.**, (CW2) 444C Carpenter Place, Fort Riley, KS 66442. Dy: (913) 239-3910. Res: (913) 784-3031. S: Michelle. Dy: Med Evac Pilot, 82nd Med Co (AA), Fort Riley, KS. RW Qual. Time: 760 Hrs.

**Kiszely, Paul Z.**, (CW2) (Magua) 636 Manning Drive, Coppas Cove, TX 78522. S: Nancy. Dy: C Co, 1-227th, 1st Cav Div, Fort Hood, TX. Flt: MTP. RW Qual. Time: 1,000 Hrs.

**Klusacek, Ronald E.**, (CW3) (Ron) 5226 Pepper Mill Drive, Corpus Christi, TX 78413. Dy: (512) 939-3166. Res: (512) 993-5321. S: Shella. Dy: Test Pilot, CCAD. Flt: MTP. RW Qual. Time: 2,800 Hrs.

**Koch, Ronald J.**, (CW2) P.O. Box 369, Anchor Point, AK 99556-0369. Res: (907) 235-7917. S: Lydia. Flt: ASO. RW Qual. Time: 1,200 Hrs.

**Kokoski, John R.**, (CW4) PSC 42, Box 11, APO AA 34042. S: Petra. Dy: Standardization Pilot, 228th Avn, Soto Cano, Honduras. Flt: SIP. RW Qual. Time: 3,500 Hrs.

**Korneli, Robert K.**, (CW2) 16312A Moran Place, Fort Polk, LA 71459. Dy: (318) 531-6667. Res: (318) 573-7021. EM: balou@worldnetia.net. S: Kerrie. Dy: 412 Armored Cavalry Regt (Light), Fort Polk, LA. Flt: IP IFE. SIP. RW Qual.

**Korycinski, Richard E.**, (CW3) (Ski) 1111 Lamorous Drive, Harker Heights, TX 76548. Dy: (254) 287-7965. Res: (254) 698-3217. EM: attkgeek@centraltx.net. S: Donna. Dy: IP. Flt: SAA IP. RW Qual. Time: 1,600 Hrs./Cbt 25 AM/1.

**Kriskowski, James J.**, (CW5) (Ski) 94-146 Makoa Street, Waluahu, HI 96797. Dy: (808) 438-1078. Res: (808) 671-7181. EM: kriskowt@shafter-emh3.army.mil. S: Beverly. Dy: US Army Pacific Avn Safety Officer, Fort Shafter, HI. Flt: MAA. RW Qual. Time: 3,400 Hrs. Past Chapter Officer.

**Kruger, Eric W.**, (WO1) 127 Lakeview Drive, Daleville, AL 36322. Dy: (334) 255-9730. EM: ekruget@snowhill.com. S: Lara.

**Labiche, Henry M.**, (WO1) (Shank) 540 Appleton Drive, Clarksville, TN 37042. Dy: (502) 798-3635. Res: (931) 905-2682. EM: bboser@rocketmail.com. S: Renea. Dy: Avn Maint Tech-PC Officer, D Co, 2-101 Avn Regt, Fort Campbell, KY.

**Laird, Jeffery A.**, (CW2) (Lumpy) 1405-B Indiana Avenue, Fort Campbell, KY 42223-3517. Dy: (502) 798-3970. Res: (931) 431-6112. S: Gia. Dy: Apache Pilot. RW Qual. Time: 360 Hrs.

**Lambrecht, John A.**, (CW2) 404 Ellie Court, Clarksville, TN 37040. Dy: (502) 798-7234. Res: (931) 920-2417. EM: stflor@proweb.com. S: Teresa. Dy: C-7101, Fort Campbell, KY. RW Qual. Time: 400 Hrs.

**Lankist, Francis W.**, (CW2) (Frank) 101 Twin Creek Drive, No. 1010, Killeen, TX 76543. Dy: (254) 287-5006. Res: (254) 699-8867. Dy: A Co, 1-4 Avn, 4 Infantry Division, Fort Hood, TX. Rtg: SAA IP IFE. RW Qual. Time: 1,850 Hrs.

**Lapping, Steven A.**, (CW3) PSC 01, Box 2294, APO AA 34001. Dy: (507) 284-5816. Res: (507) 284-3804. EM: lapping@pananet.com. S: Ivette. Dy: D/160th SOAR, Fort Kobbe, Panama. Rtg: SAA IP IFE. RW Qual. Time: 3,000 Hrs. Life Member.

**Laroche, Paul N.**, (CW2) 6718 47th Street CT W, Tacoma, WA 98466. Dy: (253) 967-3051. S: Pauline. Dy: Medevac Pilot, 54th Med Co. RW Qual. Time: 500 Hrs.

**Larsen, Duane K.**, (CW4) 630 Sperry Loop, Wahluwa, HI 96786-4110. Dy: (808) 656-1210. Res: (808) 656-4220. EM: gunner18@lava.net. Rtg: IFE. RW Qual. Time: 4,100 Hrs.

**Larson, Todd A.**, (CW3) 222 Stratford Lane, Enterprise, AL 36330. Dy: (334) 255-8667. Res: (334) 393-5729. EM: todd245@alaweb.com. Dy: UH-60 IP, C Co, 1-223d Avn. Rtg: IP. RW Qual. Time: 2,475 Hrs./Cbt 95 AM2.

**Larz, Timothy J.**, (CW3) (T.J.) 1921 Secretariate Court, Clarksville, TN 37042. Dy: (502) 798-1830. Res: (931) 431-7242. S: Vanessa. Dy: Army Aviator Rtg: IP. RW Qual. Time: 2,200 Hrs. AM1. Life Member.

**LaVoy, Lee C.**, (CW2) 819 Ringold Street, Wahluwa, HI 96786. Dy: (808) 656-2556. Res: (808) 624-5833. EM: lav101@psynot.com. S: Rita. Dy: Maintenance Test Pilot, A Co, 2-25 Avn Regt. Rtg: MTP. RW Qual. FW Qual. Time: 655 Hrs.

**Lawrenz, Paul R.**, (CW2) 525 Old Farm Road, Fayetteville, NC 28314. Dy: (910) 396-5517. Res: (910) 567-5923. S: Yvonne. Dy: B Company, 3-229 Avn Regt, Fort Bragg, NC. Rtg: IP. RW Qual. Time: 1,100 Hrs. Life Member.

**Lemons, Charles W.**, (CW3) (Wayne) P.O. Box 2616, Woodbridge, VA 22193. Res: (703) 730-8506. EM: intor@mrm.com. S: Lora. Rtg: AA MTP. Time: 1,900 Hrs. AM1. Life Member.

**Lemons, Kelly J.**, (WO1) 321 Candlebrook Drive, Enterprise, AL 36330. Res: (334) 393-8238. S: Crystal. Dy: CH-47 Pilot, Camp Humphreys, Korea. RW Qual. Time: 190 Hrs.

**Lenoir, James W.**, (CW2) (Jim) 15B Avn Co, Unit 31530, APO AE 09833. Res: (813) 671-4319. Dy: 15B Avn Co, Sinai, Egypt.

**Levin, Michael D.**, (WO1) 114D Carroll Avenue, Ozark, AL 36361. Res: (334) 774-5162. Dy: Flight Student, B Co, 1/145th Avn. Time: 60 Hrs.

**Lewis, Argiearld**, (CW2(P)) (Argie) 98th ASG, CMR 476, Box 109, APO AE 09244. EM: aclewis@swb.baynet.de. S: Carolyn. Dy: Safety Officer, Wuerzburg, Germany. Rtg: SAA. RW Qual. Time: 1,250 Hrs.

**Lewis, James S.**, (WO1) 104 Fuqua Avenue, Ozark, AL 36360-3311. Res: (334)

774-4668. Dy: Fort Rucker, AL. Rtg: IFE. FW Qual. Time: 200 Hrs.

**Lewis, Michael J.**, (WO1) D Tnp, 1/4 Cav, CMR 464, Box 711, APO AE 09226. EM: skidkid@mailexcite.com. S: Ellen. Dy: OH-58D Pilot, D Tnp, 1/4 Cav, Schweinfurt, Germany. RW Qual. Time: 640 Hrs./Cbt 21 Loomis, Paul A., (CW3) 2819 West Waterford Way, Richmond, VA 23233. Dy: (910) 396-0026. Res: (804) 360-1703. S: Mascha. Dy: SIP/IE, 57 Med Co, Fort Bragg, NC. Rtg: SAA IFE SIP. RW Qual. Time: 4,400 Hrs./Cbt 20 Life Member.

**Lowell, Steven M.**, (CW3) 42 Beaver Run, Savannah, GA 31419. Dy: (912) 767-4475. Res: (912) 920-7068. S: Tawn. Dy: OH-58D (I) Instructor Pilot, E Tnp, 3-7 Cavalry, Fort Stewart, GA. Rtg: IP. RW Qual. Time: 2,700 Hrs.

**Lucius, Douglas E.**, (CW2) (Doug) C Co, 7-158th Avn Regt, CMR 408, Box 1422, APO AE 09182. S: Raquel. Dy: UH-60 Pilot, Germany. Rtg: AA. RW Qual. Time: 400 Hrs.

**Lupien, Bradley R.**, (CW5) (Brad) 190 Calmburg Road, Richmond Hill, GA 31324. Dy: (912) 352-5940. Res: (912) 727-4908. EM: blupien@aol.com. S: Beth. Dy: Brigade Safety Officer, Hunter Army Airfield, Savannah, GA. Rtg: MAA. RW Qual. Time: 4,000 Hrs./Cbt 1,100 DFC1, AM21.

**Mees, Albert J.**, (CW3(P)) (Joey) 2016 Mixon School Road, Ozark, AL 36360. Dy: (334) 255-5043. Res: (334) 774-2208. S: Kathy. Dy: D Troop, SP 47 Cav, Korea. Rtg: SAA SIP IFE. RW Qual. Time: 4,000 Hrs./Cbt 90 AM1/V.

**Magan, Thomas J.**, (CW5) Narragansett Bay BP WO, 20 Tomahawk Court, Warwick, RI 02886-8515. Dy: (401) 267-3008. Res: (401) 738-7742. Dy: Flight Instructor, RIARNG. Rtg: MAA IFE SIP MTP. RW Qual. FW Qual. Time: 11,000 Hrs./Cbt 704 AM13. Vp. Wo Affairs, Narragansett Bay Chapter.

**Mahoney, Jeffrey A.**, (CW2) (Jeff) 202 Semline Drive, Enterprise, AL 36330. Dy: (334) 255-5084. EM: cobrdriver@awanet.com. Dy: Fort Rucker, AL. Rtg: SAA IP. RW Qual. Time: 1,000 Hrs.

**Maier, Robert F.**, (CW3) (Fluf) 115 River Park Cove, Georgetown, TX 78626. Res: (512) 869-4236. EM: gundriver@mail.utexas.edu. S: Joan. Dy: Full Time Student, C Tnp, 7-6 Cav, Army Reserve. RW Qual. Time: 900 Hrs.

**Manahan, Kevin P.**, (CW3) 351 Pesybody Drive, Apt. 1, Clarksville, TN 37042. Dy: (502) 798-3785. Res: (931) 552-7327. Dy: Avn Maint & Arm Tech, 1st Bn, 101st Avn Regt, Fort Campbell, KY.

**Mancuso, Frank S.**, (CW2) 3105 Arrow Lane, Clarksville, TN 37043. EM: chinook29@midmouth.net. S: Angela. Dy: A Co, 2-160th SOAR (A), Fort Campbell, KY. Rtg: IP. RW Qual. Time: 1,200 Hrs.

**Mankie, James A.**, (CW5) (Andy) 407 Tartan Court, Fayetteville, NC 28311. Dy: (910) 396-2308. Res: (910) 630-3325. EM: mankiea@bragg.army.mil. Dy: Corps Standardization Officer, XVIII Airborne Corps, Fort Bragg, NC. Rtg: MAA IFE SIP. RW Qual. Time: 5,250 Hrs./Cbt 950 AM2.

**Manley, James E.**, (CW5) (Jim) 301 Valley Stream Drive, Enterprise, AL 36330. Dy: (334) 255-8441. Res: (334) 393-0552. S: Lynda. Dy: Chief of Standards, 1-223d Avn, Fort Rucker, AL. Rtg: MAA SIP IFE. RW Qual. Time: 5,700 Hrs./Cbt 868 AM16.

**Mann, Leon A., Jr.**, (CW5) (Larry) 4028 Hidden Spring Court, Fort Irwin, CA 92310. Dy: (760) 380-4167. Res: (760) 386-2257. S: Joyce. Dy: Installation & Standardization Officer, Fort Irwin, CA. Rtg: MAA IFE SIP RW Qual. Time: 6,000 Hrs./Cbt 200 AM1. Life Member. Past Chapter Officer, Bronze Osm.

**Marine, Anthony P.**, (CW4) (Tony) 105 Boxwood Drive, Enterprise, AL 36330. Dy: (334) 255-4058. Res: (334) 393-5419. S: Annette. Dy: TH67 SIP/Chief Contract Eval Pilot, Fort Rucker, AL (Lowe AHP). Rtg: SIP. RW Qual. Time: 4,500 Hrs.

**Marler, Jeffrey S.**, (CW2) (Jeff) A Co, 2-1 Aviation, CMR 454, Box 2384, APO AE 09250. S: Kristy. Dy: UH-60 Pilot, Katterbach, Germany. RW Qual. Time: 700 Hrs.

**Marr, Paul D.**, (CW4) (Papaer) CMR 454, Box 2199, APO AE 09250. EM: marp@email.ansbach.army.mil. S: Diana. Dy: 4th Bde, 11D Standards Officer, Katterbach, Germany. Rtg: SIP IP. RW Qual. FW Qual. Time: 4,400 Hrs./Cbt 150

**Marshall, Mark D.**, (CW2) 3502 Cadet Sheridan Road, No. A, Wahluwa, HI 96786. Dy: (808) 656-2543. Res: (808) 624-3374. EM: mmarshub60@aol.com. S: Bernice. Dy: B Co, 2-25 Avn Regt, Wheeler Army Airfield, HI. Rtg: AA NVG PIC ASO. RW Qual. Time: 1,300 Hrs./Cbt 32 AM2.

**Marshall, Michael P.**, (CW2) 4400 Decatur Drive, Woodbridge, VA 22193. Dy: (703) 806-7621. Res: (703) 730-6171. EM: rastaboy@erols.com. S: Niurka. Dy: Pilot, A Co, 12th Avn Bn. RW Qual. Time: 530 Hrs.

**Martin, Carl R.**, (CW3) (Slick) 2073th Avn Co, PSC 29231, Box 123, APO AE 09102. EM: martinrc@hq.hqsareur.army.mil. S: Louanne. Dy: 207th Avn Co, Heidelberg, Germany. Rtg: SAA MTP. RW Qual. Time: 3,200 Hrs./Cbt 40 AM1.

**Martin, Gerald M.**, (CW2) (Jerry) 39 East Harris Drive, Fort Rucker, AL 36322. Dy: (334) 255-5051. Res: (334) 503-9934. S: Linda. Rtg: IP. RW Qual. Time: 2,000 Hrs.

**Martin, John E.**, (CW4) (Jack) C Co, 52nd Avn Regt, Unit 15203, Box 198, APO AP 96271-0139. EM: jackscom@inet.att.co.kr. S: Teresa. Dy: Maintenance Platoon Leader, C152 Avn Regt (AVIM). Rtg: SAA TP ME. Time: 2,600 Hrs.

**Martin, Mary J.**, (CW3) CMR 416, Box 561, APO AE 09140. EM: martinmj@email.ansbach.army.mil. S: Rebecca. Dy: Regiment Safety Officer, 11th Aviation Regiment, Ilesheim, Germany.

**Marvin, Robert A.**, (WO1) (SkyKing) 88 Woodfield Place, Enterprise, AL 36330. Dy: (334) 255-9023. Res: (334) 347-8276. S: Jennifer. Dy: B Co, 1 Bn, 145 Avn Regt. Rtg: AA. RW Qual. Time: 163 Hrs. AM3.

**Mason, Robert A.**, (CW5) (Bob) CMR 454, Box 2034, APO AE 09250. Dy: Tactical Operations Officer, HHC, 4 Bde, 1 ID, Katterbach, Germany. Rtg: MAA SIP IP. RW

Qual. Time: 5,500 Hrs./Cbt 500 AM/18, V. Life Member. Bronze Osm.

**Mau, Clay A.,** (CW4) P.O. Box 620207, Fort Rucker, AL 36362-0207. Dy: (334) 255-4059. Res: (334) 598-9083. EM: clayma@snwhill.com. Dy: E Co, 1-212 Avn, Fort Rucker, AL. Rtg: AA SIP. RW Qual. Time: 5,500 Hrs./Cbt 90 AM/1.

**Mauss, Daniel H.,** (CW4) 159th Med Co, CMR 467, Box 4587, APO AE 09096. EM: mauss/home@aol.com. S: Irene. Dy: Standardization Officer. Rtg: MAA IP. RW Qual. Time: 4,000 Hrs.

**May, Rick W.,** (WO1) (Rick) 901 Hunter Lane, Clarksville, TN 37043-2117. Dy: (502) 798-4562. Res: (615) 906-9477. S: Isabella. Dy: UH-60 Pilot. RW Qual. Time: 250 Hrs. AM/1.

**Mayers, Ed R., Jr.,** (CW5) 1302 Thompson Street, Taylor, TX 76574. Dy: (817) 287-8325. Res: (512) 352-3094. S: Phyllis. Dy: HHC USAG, Fort Hood, TX. Rtg: MAA IFE SIP. RW Qual. Time: 5,500 Hrs./Cbt 500 Past Chapter Officer.

**Mayers, Gary W.,** (CW2) (Sharkn) C Co, 1-52nd Avn, Unit 15508, Box 719, APO AP 96205-0575. EM: sharkn@juno.com. Dy: UH-60 MTP, Korea. Rtg: MTP. RW Qual. FW Qual. Time: 1,100 Hrs.

**McCall, Timothy M.,** (CW3) 5800 Chatsworth Court, Arlington, TX 76018. Dy: (972) 266-6980. Res: (817) 465-6279. EM: timcall@sprintnet.com. S: Deborah. Dy: SIP RASFTD, TXANG, NAS Dallas, TX. Rtg: IFE SIP. RW Qual. FW Qual. Time: 4,500 Hrs./Cbt 200 AM/2.

**McCauley, Radford C.,** (CW3) (Cactus) 88 Lewis Drive, Richmond Hill, GA 31324. S: Virginia. Dy: E Trip, 3-7 Cav, Fort Stewart, GA. Rtg: SAA IP. RW Qual. Time: 2,014 Hrs./Cbt 57 AM/3.

**McClendon, Barrin K.,** (WO1) 547 Somerset Lane, Clarksville, TN 37042. Res: (931) 906-6008. S: Kimala. Dy: 50th Medevac Co (AA), Fort Campbell, KY.

**McCluskey, Gary W.,** (CW2) (Gator) 4206 Water Oak Drive, Killeen, TX 76542. Dy: (254) 288-3078. Res: (254) 690-8360. Dy: C Co, 2-4 Avn, Fort Hood, TX. RW Qual.

**McConnell, John,** (CW3) 2422 English Hill Drive, Murfreesboro, TN 37130. Dy: (615) 355-3791. Res: (615) 867-1393. EM: rufusjm@aol.com. Dy: Unit Trainer, RTD 4/27th ACR. Rtg: SAA IFE SIP IP MTP. RW Qual. Time: 2,000 Hrs.

**McConnell, Steven L.,** (CW3) Box 195, CMR 401, APO AE 09076-0195. S: Susan. Dy: D Trip, 1-1 Cav, Buedingen, Germany. Rtg: IFE SIP. RW Qual. Time: 2,500 Hrs.

**McElhinney, Lance V.,** (CW5) 6640 Rose Street, Fort Hood, TX 76544. Dy: (254) 618-8170. Res: (254) 539-5276. S: Barbara. Dy: 4th Bde, 4th ID, 1st Bn Sids Officer. Rtg: AA SIP. RW Qual. Time: 6,048 Hrs./Cbt 1,006 DFC1/AM/26V. Past Chapter Officer.

**McElmurry, Todd A.,** (CW2) A Co, 5-159th Avn Regt, CMR 408, Box 350, APO AE 09182. S: Carl. Dy: CH-47D Pilot, Giebelstadt, Germany. RW Qual. Time: 1,100 Hrs.

**McManus, William J.,** (CW2) (Joe) 520

Barney Lane, Clarksville, TN 37042. Dy: (502) 798-1514. Res: (615) 920-5542. S: Jeri Lynn. Dy: D 1/60, Fort Campbell, KY. RW Qual. Time: 1,500 Hrs.

**McNiff, Owen A.,** (CW3) (Omar) 751st MI Battalion, Box 183, APO AP 96271. EM: labck-fs-phx-om@emh1.korea.army.mil. S: Jeong. Dy: AMO/MTP/MTFE, Camp Humphreys, Korea. Rtg: SAA IP SIP MTP. RW Qual. Time: 4,300 Hrs.

**McSherry, Patrick R.,** (CW2) PSC 42, Box 536, APO AA 34042. EM: mosherrp@jfb-emh1.army.mil. Dy: D Co, 228 Avn Regt, Soto Cano, Honduras. Rtg: AA. RW Qual. Time: 850 Hrs.

**McWaters, Tony H.,** (CW4) 145 Lakeside Court, Fayetteville, GA 30214. Dy: (770) 919-5644. Res: (770) 716-0896. EM: tony\_mcwaters@compuserve.com. S: Denise. Dy: UC35 SPIIE, Dobbins AFB, GA. Rtg: MAA IFE SIP IE. RW Qual. FW Qual. Time: 4,200 Hrs./Cbt 100 AM/2.

**Means, Sargent B.,** (CW4) (Sarge) 210 N. Pontiac, Dothan, AL 36303. Dy: (334) 255-8569. Res: (334) 794-3163. EM: sargesz@aol.com. S: Stephanie. Rtg: IFE IP. RW Qual. FW Qual. Time: 5,300 Hrs./Cbt 1,300 AM/4, DFC/1.

**Meduna, Chad R.,** (WO1) (Ferris) 103 Seminole, Enterprise, AL 36330. Res: (334) 393-7096. Dy: Student Pilot, Fort Rucker, AL. RW Qual. Time: 100 Hrs.

**Meely, Michael J.,** (CW4) (Mike) 1672 East Oakland Street, Chandler, AZ 85225-5277. Dy: (602) 891-3248. Res: (602) 963-8255. EM: mmeely@aol.com. S: DeAnn. Dy: A Company, 1-14th Avn. Regt. (Longbow Training Co.). Rtg: IFE SIP. RW Qual. Time: 3,300 Hrs./Cbt 50 AM/2.1V.

**Meierls, Jeffrey F.,** (WO1) 27 Duke Street, Fort Rucker, AL 36362. Dy: (334) 255-9911. S: Sheri. Dy: Flight Student, B Co, 1/145th Avn. Time: 36 Hrs.

**Mercado, David,** (CW2) (Merc) 2190 Memorial Drive, Apt. E102, Clarksville, TN 37043. Dy: (931) 798-1167. Res: (931) 684-8454. S: Tina. Dy: C Co, 1-160th SOAR, Fort Campbell, KY. Rtg: SAA IP. RW Qual. FW Qual. Time: 2,500 Hrs./Cbt 150 AM/1. Life Member.

**Mikeska, E.J., Jr.,** (CW4) (E-Hogg) 16011 Mickey Drive, Austin, TX 78717. Dy: (254) 288-1414. Res: (512) 238-7941. EM: e\_hogg@compuserve.com. S: Karen. Dy: Production Control Officer, D Co, 1-227 Avn, Fort Hood, TX. Rtg: SAA IP MTP. RW Qual. Time: 2,550 Hrs.

**Miller, Clinton A.,** (WO1) 2137 Martha's Chapel Road, Apex, NC 27502. EM: clintonmiller@hotmail.com. S: Tracy. Dy: 377th Med Co (AA), Camp Humphreys, Korea. Rtg: AA. RW Qual. Time: 215 Hrs.

**Miller, Thomas A.,** (CW2) (Andy) P.O. Box 5870, Fort Hood, TX 76544-0870. EM: millercw2@aol.com. Dy: 3-4 Cav, 21st Cav Bde, Fort Hood, TX. RW Qual. Time: 280 Hrs.

**Milligan, David E.,** (CW3) (Stew) 2814 Partridge Lane, Enterprise, AL 36330. Dy: (334) 255-9857. Res: (334) 393-8112. EM: milligad@safety-emh1.army.mil. S: Patty. Dy: US Army Safety Center, Fort Rucker, AL.

Rtg: SAA. RW Qual. Time: 1,650 Hrs./Cbt 50 AM/1. Past Chapter Officer. 96 Medalian Award.

**Moczynski, Dale P.,** (CW3) (Skiman) D Troop, 1-4 Cav, CMR 464, Box 536, APO AE 09226. EM: dmoczynski@swcybersurf.de. S: Renate. Dy: 1-4 Cav, Schweinfurt, Germany. Rtg: SAA IP IE. RW Qual. Time: 3,000 Hrs./Cbt 40 AM/1.

**Moffitt, William D.,** (CW2) (Bill) 409 Wapiti Drive, Spring Lake, NC 28390. Dy: (910) 396-3788. Res: (910) 497-6426. S: Julie. Dy: D Trip, 1/17 Cav, 82nd Avn Bde, Fort Bragg, NC. RW Qual. Time: 400 Hrs.

**Moinlan, Shapour,** (CW3) (Shop) 1911 Oakview Drive, Fayetteville, NC 28304. Dy: (910) 396-3289. Res: (910) 868-6592. S: Anka. Dy: Chief, Quality Control & Safety, I Company, 4-159th Avn Maint Bn. Rtg: ME. RW Qual. FW Qual. Time: 3,100 Hrs.

**Moltenberg, John S.,** (CW4) (John) 3010 Ira Young Drive, Apt. 1102, Temple, TX 76504. Res: (254) 747-6388. EM: moltenberny@usfk.korea.army.mil. S: Teri. Dy: Production Control Officer/ME, F Troop, 4-7 Cav, APO AP. Rtg: MAA MTP IP. RW Qual. Time: 7,500 Hrs. 91 Trainer Of Year.

**Monette, Patrick A.,** (WO1) 102 Iroquois Drive, Enterprise, AL 36330. Dy: (334) 255-9730. Res: (334) 393-9220. EM: army\_avbr@hotmail.com. Dy: Student Aviator, Fort Rucker, AL. Time: 65 Hrs.

**Moody, Ronald K.,** (CW4) (Bigfoot) 3941 Bitter Springs Drive, Fort Irwin, CA 92310. Dy: (760) 390-3638. Res: (760) 386-2739. EM: eagle51@irwin.mil. S: Dona. Dy: Commander, Eagle Flight Detachment, OPS Group, Fort Irwin. Rtg: IFE SIP. RW Qual. Time: 6,800 Hrs./Cbt 150 AM/1.

**Moorehead, Michael T.,** (CW5) (Mike) 17 Faith Lane, Fort Rucker, AL 36362-2427. Dy: (334) 255-8703. Res: (334) 503-9025. EM: moorehem@safety-emh1.army.mil. S: Vickie. Dy: Safety Officer/Investigator USASG, Fort Rucker, AL. Rtg: AA SIP. RW Qual. FW Qual. Time: 5,200 Hrs./Cbt 250 AM/4. V. Past Chapter Officer.

**Moran, Homer L.,** (CW4) (Larry) A Co, 127th ASB, Comanche, Base, Operation Joint 8th, APO AE 09789. EM: 127asbop8@127th.1ad.army.mil. S: Bonnie. Dy: Aviation Maintenance Officer, Support Operations. Rtg: AA. Life Member.

**Moran, John T.,** (WO1) 733 E 2nd Avenue, No. 201, Denver, CO 80203. Dy: (334) 255-9961. Res: (334) 702-9540. S: Christie. Dy: 4th Squadron, 3rd ACR, Fort Carson, CO. RW Qual.

**Morgan, James D.,** (CW4) (Jim) 3604 Hillcrest Drive, Lumberton, NC 28358. Dy: (910) 432-5174. Res: (910) 738-7728. EM: morganj@bragg-emh5.army.mil. S: Debbie. Dy: 82nd Avn Bde, Sids Officer, Fort Bragg, NC. Rtg: MAA IFE SIP. RW Qual. Time: 4,100 Hrs./Cbt 80 AM/1.

**Morgan, Phillip M.,** (WO1) 107 Woodfield Place, Enterprise, AL 36330. Dy: (334) 782-1100. Res: (334) 347-8274. Dy: Aviator Student.

**Morgan, Ted M.,** (CW2) (Teddy) 19 Diamond Circle, Fort Rucker, AL 36362. Dy: (334)

598-2228. EM: morgant@usfk.korea. army. mil. S: Cynthia. Dy: D Trp, 4-7 Cav, Camp Stanton, Korea. RW Qual. Time: 400 Hrs.

**Morgan, Timothy L.**, (CW2) E Troop, 47 Air Cav, Unit 15122, Camp Stanton, APO AP 96251. EM: killer6d@hotmail.com. S: Audrey. RW Qual. Time: 325 Hrs.

**Moring, Ronald C.**, (CW4) (Ronnie) 30 Hunt Street, Fort Bragg, NC 28307. Dy: (910) 396-1478. Res: (910) 497-2115. S: Rene. Dy: Regimental Master Gunner, HHC, 229th AHR. Rtg: MAA SIP. RW Qual. Time: 3,600 Hrs./Cbt 10 AM/1.V.

**Morrill, Robert L.**, (CW3) (Mr. Bob) CMR 477, Box 1417, APO AE 09165. EM: morrill@email.hanau.army.mil. Dy: Production Control Officer, D Co, 2-501st Avn Regt.

**Morrill, Sean**, (CW3) 1812 Diana Lane, Harker Heights, TX 78648. Dy: (254) 288-1180. Res: (254) 698-1218. EM: morrills@emh3.hood.army.mil. S: Renee. Dy: RC-12D Pilot, HSC 15th Mi, Fort Hood, TX. Rtg: SAA. RW Qual. FW Qual. Time: 3,130 Hrs./Cbt 43 AM/1.

**Morris, Ed**, (CW3) (Edmo) 111 Blackhawk Drive, Daleville, AL 36322. Res: (334) 598-8077. Dy: ATB Standards, Fort Rucker, AL. Rtg: SAA SIP IP MTP. RW Qual. Time: 3,800 Hrs./Cbt 150 AM/1.

**Morris, Jeff L.**, (CW3) (Mo) 2056-A Shanshan Drive, Fort Campbell, KY 42223. Dy: (502) 798-2597. Res: (931) 431-9748. S: Karen. Dy: 8-101st Avn Regt, Fort Campbell, KY. Rtg: MTP. RW Qual. Time: 1,500 Hrs./Cbt 150 AM/2.

**Muckleroy, James L.**, (CW3) (Muck) 4 Avocet Way, Savannah, GA 31419-8368. Dy: (912) 352-6070. Res: (912) 925-3038. S: Theresa. Dy: AH-64 IP/IFE, Hunter AAF, 1-24th Avn. Rtg: IP IFE. RW Qual. Time: 1,550 Hrs./Cbt 40 AM/1.

**Mull, Jr., Lawrence A.**, (CW4) (Lamy) B Co, 7-159th Avn Regt., CMR 408, Box 962, APO AE 09182. EM: bco159-nc@email.wuerzburg.army.mil. S: Yongi. Dy: Production Control/Tech Supply, Giebelstadt, Germany. Time: 2,100 Hrs. Life Member.

**Murdoch, Mark M.**, (CW3) CMR 454, Box 2540, APO AE 09250. S: Cathy. Dy: 45th Med Co (AA), Ansbach, Germany. Rtg: IP IFE. RW Qual. Time: 2,400 Hrs.

**Myers, Joe N.**, (CWS) 1005 Nez Perce Street, Moscow, ID 83843. Dy: (502) 798-2029. Res: (208) 883-7963. EM: myersmtp@turbonet.com. S: Carrie. Dy: Division MTFE, 101st Abn Div. Rtg: MAA MTP. RW Qual. Time: 3,500 Hrs. AM/1.

**Myers, Raymond A.**, (CW4) (Ray) CMR 416, Box 34, APO AE 09140. EM: myersr@email.ansbach.army.mil. S: Kim. Dy: 11th Aviation Regiment, Ilesheim, Germany. Rtg: MTP. RW Qual. Time: 3,000 Hrs.

**Napoli, Stephen S.**, (WO1) 404 S Fryers Creek Circle, Temple, TX 76504. Dy: (254) 288-9733. Res: (254) 899-2071. EM: ssnapoli1@aol.com. Dy: C Co, 1-227 Avn Regt, Fort Hood, TX. RW Qual. Time: 250 Hrs.

**Navarro, Herbert R.**, (CW3) (Herb) 3809 Old Mill Run, Dothan, AL 36303. Dy: (334) 255-2654. Res: (334) 793-4148. EM:

n39965@aol.com. S: Shirley. Dy: IP Aviator, HHC ATB Core Section Chief, Fixed Wing Korea. Rtg: SAA IP. RW Qual. Time: 3,500 Hrs./Cbt 31 AM/1.

**Nee, Steve E.**, (CW4) 110 Caldwell Court, Daleville, AL 36322. Dy: (334) 255-5084. EM: snee@prodigy.com. S: Marianne. Dy: 1-14 Avn Regt, IPC/MOI Pil Ldr, Fort Rucker, AL. Rtg: MAA SIP. RW Qual. Time: 4,750 Hrs./Cbt 250 AM/2.V.

**Nelson, Michael E.**, (CW3(P)) (Mike) 2812 Rocky Branch Road, Enterprise, AL 36330. Dy: (334) 255-5051. Res: (334) 393-0538. EM: menelson@snowhill.com. S: Marion. Dy: C Co, 1-14th Avn Regt Operations Officer, Fort Rucker, AL. Rtg: SIP IP MTP. RW Qual. Time: 3,700 Hrs./Cbt 75 AM/1.

**Newsom, Larry W.**, (CW5) Iron Mike Cnp VP Prog., P.O. Box 70718, Fort Bragg, NC 28307-0718. Dy: (910) 396-7569. Res: (910) 487-1426. EM: larrynewsom@sprintmail.com. S: Carol. Dy: 18th Avn Bde, Fort Bragg, NC. Rtg: MAA. RW Qual. Time: 3,600 Hrs./Cbt 781 AM/2. Life Member. Vp, Programs, Iron Mike Chapter Bronze Osm.

**Noble, Norman R.**, (CW4) (Frandy) 606 Henderson Street, Enterprise, AL 36330-1353. EM: noble@snowhill.com. Dy: DES, Fort Rucker, AL. Rtg: MAA IP MTP. ME. RW Qual.

**Noble, Zachary Q.**, (CW2) 2375 Riverchase Place, Fayetteville, NC 28306. EM: attack1@aol.com. S: Gae. Dy: A1-229 Avn Regt, Fort Bragg, NC. Rtg: IP. RW Qual. Time: 1,600 Hrs.

**Norrl, Jukka**, (CW4) 207th Aviation, Unit 29231, Box 35, APO AE 09102-5000. S: Elna. Dy: Maintenance Officer, Heidelberg, Germany. Rtg: MAA MTP. ME. RW Qual. Time: 3,700 Hrs./Cbt 20 AM/2.

**Ohnheiss, Scott E.**, (CW4) 151 St Lo Drive, Fort Carson, CO 80913. Dy: (719) 526-5691. Res: (719) 538-4577. S: Cindy. Rtg: MTP. RW Qual. Time: 2,025 Hrs./Cbt 14 AM/2. Bronze St. Michael.

**Olin, Michael S.**, (CW4) 6713 Foxberry Road, Fayetteville, NC 28314. Dy: (910) 396-6833. Res: (910) 860-1712. EM: olinsm@aol.com. S: Nora. Dy: Army Parachute Team, Fort Bragg, NC. Rtg: MAA ASO. RW Qual. FW Qual. Time: 5,200 Hrs. 92 Medallion Award.

**Olson, Donn D.**, (CWS) 11690 Benington Woods Rd., Reston, VA 22094-1610. Dy: (703) 695-9636. S: Sherry. Dy: HQDA, ODC-SOPS, DAMO-FDV, Pentagon, Washington, DC. Rtg: MAA SIP. RW Qual. Time: 7,059 Hrs./Cbt 2,000

**Osterlund, Richard B.**, (CW5) (Rick) 8009 Rockwood Drive, Milford, KS 66514. Dy: (785) 239-2090. Res: (785) 223-0909. EM: osterlund@riley-emh1.army.mil. S: Sue. Dy: Commander, Airfield Operations Detachment, Fort Riley, KS. Rtg: MAA SIP IFE. RW Qual. Time: 7,500 Hrs.

**Owens, Stacy L.**, (CW2) 119 Foxhill Drive, Enterprise, AL 36330-1607. Dy: (334) 255-4032. Res: (334) 393-2318. Dy: A 1-21 Avn Regt, Fort Rucker, AL. Rtg: AA IP ASO. RW Qual. Time: 1,600 Hrs.

**Paget, Cleve G.**, (CW2) 6 Wall Place, Fort

Bragg, NC 28307. Dy: (910) 396-2671. Res: (910) 436-4320. EM: ogpaget@aol.com. S: Jennifer. Dy: C Trp, 1-17th Cav, Fort Bragg, NC. Rtg: IP. RW Qual. FW Qual. Time: 1,400 Hrs. Life Member.

**Pais, Rodney L.**, (CW2) (BigDaddy) C Co, 2-501st Avn Regt, Operation Joint Guard, APO AE 09165. EM: rpais@usa.net. S: Rhonda. Dy: UH-60 IP, Tuzla, Bosnia-Herzegovina. Rtg: AA IP. RW Qual. Time: 1,700 Hrs.

**Parisher, Terry W.**, (CW2) 16209A Richmond Place, Fort Polk, LA 71459. Dy: (318) 531-6477. Res: (318) 537-8620. S: Theresa.

**Pascalar, Michael C.**, (CW4) (Mike) 207th Aviation Company, Unit 29231, Box 193, APO AE 09102. EM: pascalar@compuserve.com. S: Susan. Dy: UC35 SP, Heidelberg AAF. Rtg: MAA IFE SP. RW Qual. FW Qual. Time: 7,300 Hrs. AM/1. Life Member. Past Chapter Officer. Bronze Osm.

**Paulson, Daniel J.**, (CW2) 724 Ridgewood Drive, Manhattan, KS 66502-3232. Dy: (913) 239-0302. Res: (913) 785-1733. EM: chiefdan@hotmail.com. Dy: UH-1 Pilot, 82nd Medical Company (AA).

**Pearson, David L.**, (CW2) (Dave) C Co, 7-158th Avn, CMR 408, Box 1491, APO AE 09182. EM: dnpear@aol.com. S: Terri. Dy: C Co, 7-158th Avn, Giebelstadt, Germany. RW Qual. Time: 525 Hrs.

**Pease, Donald F.**, (CW4) (Don) 8 Ashton Road, Savannah, GA 31419. Dy: (912) 353-2669. Res: (912) 925-3326. EM: dpease@ibm.net. S: Linda. Dy: B Co, 2-3rd Avn Regt, Hunter Army Airfield, GA. Rtg: MAA SIP. RW Qual. Time: 4,600 Hrs./Cbt 145 AM/1. Bronze Osm.

**Peay, Earl G.**, (CWS) (Gene) 3001 Park Center Drive, Apt. 1605, Alexandria, VA 22302-1437. Dy: (703) 325-5186. Res: (703) 379-2863. EM: peaye@hoffman-emh1.army.mil. S: Sandy. Dy: PERSSCOM, Alexandria, VA. Rtg: MAA IP. RW Qual. Time: 4,500 Hrs./Cbt 850 DFC/1, AM/20.

**Peckham, Stephen W.**, (CW4) (Steve) 825 South Lee Street, Alexandria, VA 22314. Res: (703) 299-8878. Dy: Maintenance Officer, USA INSCOM. Rtg: MAA MTP IP. RW Qual. FW Qual. Time: 2,500 Hrs. Life Member.

**Pellegrino, Matthew M.**, (CW3) (Matt) 78th Aviation BN (P), Unit 45007, Box 84, APO AP 96338-5007. EM: matthew@tconet1.jtcs.jcs.mil. S: Pok Yun. Dy: Bn Safety Officer, 78th Avn UH60UH1 Pilot. RW Qual. Time: 2,000 Hrs. Secretary, Rising Sun Chapter.

**Pena, Alfred**, (CW4) (Fred) 304 Northside Drive, Enterprise, AL 36330. Dy: (334) 255-4060. Rtg: IP MTP. RW Qual. Time: 3,500 Hrs.

**Penick, Edward S.**, (CW4) (Ed) 308 E. Emerald Drive, Enterprise, AL 36330. Dy: (334) 255-5051. Res: (334) 347-0127. EM: edp@snowhill.com. Dy: C Co, 1-14 Avn, Fort Rucker, AL. Rtg: MAA SIP. RW Qual. Time: 5,600 Hrs.

**Peterson, Arthur F.**, (CW3) 23 S. Broad Street, West Carthage, NY 13619. Dy: (315) 772-6619. Res: (315) 493-8984. EM:

ahp@mcnet.net. Dy: B 2/10 Avn, Fort Drum, NY. Rtg: MTP AA. RW Qual. Time: 1,450 Hrs./Cbt 120 AM/2.

**Peterson, John L.**, (CW5) CMR 430, Box 718, APO AE 09096. EM: peterscj@email.hansau.army.mil. S: Jo Ann, Dy: Standardization Officer, 4th Bde, 1 AD, Hanau, Germany. Rtg: MAA IFE SIP RW Qual. Time: 5,200 Hrs./Cbt 735 DFC1, AM/30. Past Chapter Officer.

**Peters, Mark A.**, (WO1) 202 Fuqua Avenue, Ozark, AL 36360. Dy: (334) 255-9950. Res: (334) 445-1270. S: Rebecca.

**Petrak, William J.**, (CW3) (Bill) HHC 100th ASG, CMR 415, Box 4722, APO AE 09114. EM: aetmmtf@email.grafenwoehr.army.mil. S: Judy, Dy: Airfield Safety Officer, 7th ATC Flight Det. Rtg: AA. RW Qual. Time: 2,000 Hrs.

**Petrescu, Octavian A.**, (CW2) (Adrian) 2230 Twin Oaks Drive, Watertown, NY 13601-1730. Res: (315) 779-9887. EM: petr-uscu@juno.com. S: Lisa, Dy: Fort Drum, NY. RW Qual. Time: 280 Hrs.

**Plau, William E.**, (CW4) (Bill) 7810 Boyce Street, Fort Meade, MD 20755. Dy: (301) 677-4378. Res: (410) 672-3488. EM: wplau@aol.com. S: Lynda, Dy: TSB Meade, Fort Meade. Rtg: MAA IP ASO. RW Qual. Past Chapter Officer.

**Phares, William F.**, (CW2) (Bill) 510 Tobacco Road, Lot 97, Clarksville, TN 37042-4917. Dy: (502) 798-5831. Res: (931) 645-9850. EM: pharoes@compuser.net. S: Kelly, Dy: 50th Medical Company (Air Ambulance), Fort Campbell, KY. RW Qual. Time: 610 Hrs.

**Phillabaum, John E.**, (CW3) 50 Boyce Lane, Fort Rucker, AL 36362. Res: (334) 598-8042. EM: philla@snowhill.com. S: Kim, Dy: Instructor Pilot, Fort Rucker. Rtg: SAA IP. RW Qual. Time: 2,000 Hrs.

**Phillips, Michael K.**, (CW2) 1323 Carole Court, Fayetteville, NC 28314-6062. Dy: (910) 396-0026. EM: longwood89@aol.com. Rtg: ASO, 57th Medical Co., Fort Bragg, NC. RW Qual. Time: 900 Hrs. Life Member.

**Phipps, Curtis R.**, (CW3) E Troop, 1-4 Cav, CMR 464, Box 377, APO AE 09226. EM: phipps@swcybersurf.de. S: Laura, Dy: E Tp, 1-4 Cavalry, Schweinfurt, Germany. Rtg: IP IE. RW Qual. Time: 2,800 Hrs./Cbt 190.

**Pieper, Fred**, (CW3) 508 Crestview Drive, Chapman, KS 67431. Res: (913) 922-6308. EM: fd-pieper@worldnet.att.net. S: Jeanine, Dy: AH-64 Test Pilot. Rtg: SAA MTP. RW Qual. FW Qual. Time: 1,500 Hrs./Cbt 48 AM/2. Past Chapter Officer.

**Poland, Anthony W.**, (CW2) (Tony) 1520 1st Street, Apt. B, Fort Campbell, KY 42223. Dy: (502) 798-4738. Res: (931) 431-7508. S: DeReatha, Dy: C Co, 6/101 Avn Regt, Fort Campbell, KY.

**Poulos, Thomas W.**, (CW4) (Tom) 5408 Rossell Loop, Fort Belvoir, VA 22060-1918. Dy: (703) 806-7031. Res: (703) 781-7821. EM: poulosto@airfield.belvoir.army.mil. S: Nancy, Dy: MTP/ME, D Co, 12th Avn Bn, Fort Belvoir, VA. Rtg: MTP. RW Qual. Time: 2,000 Hrs.

**Powell, Bradford A.**, (CW5) (Boog) 1685 Deepwood Drive, Clarksville, TN

37042-6935. Dy: (502) 798-1837. Res: (931) 647-7688. EM: powellb@scar.net. S: Kathleen, Dy: 160th Spec Ops Avn Regt, Syst Integ Ofc, Fort Campbell, KY. Rtg: MAA IP. RW Qual. Time: 4,000 Hrs. Life Member. 93 Awa Ass Award.

**Pratt, Michael J.**, (CW3) (Mike) Route 2, Box 223H, Lillington, NC 27546. Res: (910) 893-4592. S: Renee, Dy: A Co, 2-82, UH-60 Pilot, Fort Bragg, NC. Rtg: MTP ME. RW Qual. FW Qual. Time: 2,200 Hrs./Cbt 25 AM/1.

**Prieto, Jose E.**, (CW4) (Joe) 7 Cove Drive, Savannah, GA 31419. Dy: (912) 692-8748. Res: (912) 925-3442. S: Karen, Dy: MH-47D Special Operations Pilot, B Co, 3-160th SOAR (Abn). Rtg: MAA IP. RW Qual. Time: 4,200 Hrs./Cbt 135 AM/2.

**Pugh, Stacy M.**, (CW2) (Sheard) 2826 Hinson Road, Woodland, TN 37191. Dy: (502) 798-4444. Res: (931) 905-1378. S: Chad, Dy: B/5-101 Avn, Fort Campbell, KY. RW Qual.

**Quinolones, Raymond A.**, (CW3) (Tony) 9 Stratford Lane, Enterprise, AL 36330. Dy: (334) 255-8999. Res: (334) 347-3210. S: Linda, Dy: Company Exec. Officer, Operations Officer, and Bilingual Inst. Pilot. Rtg: SAA IP. RW Qual. Time: 1,600 Hrs./Cbt 3 AM/1. Life Member.

**Ramon, Sergio**, (CW2) (Serg) 1904 Stardust St, Killeen, TX 76543. Dy: (817) 288-5144. Res: (817) 690-8405. S: Mary, Dy: B Co, 1-158 Avn Regt, 21st Cav Bde, Fort Hood, TX. Rtg: IP. RW Qual. Time: 1,000 Hrs.

**Ramser, David R.**, (CW2) (Fluss) A Co, 2nd Bn, 501st Avn, CMR 477, Box 1429, APO AE 09165-8197. EM: ramserd@email.hansau.army.mil. S: Nadia, Dy: Aviation Safety Officer. RW Qual. Time: 1,500 Hrs.

**Ramsey, William H.**, (CW5) (Fuf) 700 Wildwood Drive, Enterprise, AL 36330. Dy: (334) 255-2785. Res: (334) 393-3481. EM: ramseyw@safety-emh1.army.mil. S: Terry, Dy: Aviation System Manager, U.S. Army Safety Center, Fort Rucker, AL. Rtg: MAA ASO IP. RW Qual. Time: 7,000 Hrs./Cbt 70 AM/3.

**Ray, Bruce L.**, (WO1) (Bruce) C Co, 1/52nd Avn, Unit 15508, Box 737, APO AP 96205-0575. EM: blee13@aol.com. RW Qual. FW Qual. Time: 2,000 Hrs.

**Reardon, James C.**, (CW4) (Jim) 4313 Loma Hermosa Drive, El Paso, TX 79934. Res: (915) 822-8984. S: Stephanie, Dy: C Co, 204th MI Bn, C-12, SIP/IFE, Fort Bliss, TX. Rtg: SAA IFE SIP IP MTP. RW Qual. FW Qual. Time: 4,350 Hrs.

**Reese, Greg**, (CW5) (Iceman) 1500 Poquoson Avenue, Poquoson, VA 23062-1824. Dy: (910) 396-5503. S: Carmenza, Dy: Bn Aviation Standardization Officer, 56th Med Evac Bn. Rtg: IFE SIP. RW Qual. Time: 6,900 Hrs./Cbt 1,200 DFC1, AM/22.

**Reese, Michael L.**, (CW3) 10 Edgell Drive, No. 4, Dothan, AL 36301-1082. Dy: (334) 255-5058. Res: (334) 677-3813. S: Melinda, Dy: AH-64 Instructor Pilot, Fort Rucker, AL. Rtg: IP. RW Qual. Time: 1,900

Hrs. AM/1.

**Reichert, Kevin L.**, (WO1) C Tpt, 6-6 Cav, CMR 416, Box 687, APO AE 09140. Res: (334) 598-9143. S: Ridgely, Dy: Pilot. RW Qual. Time: 275 Hrs.

**Richards, Brett A.**, (CW2) 113 Edinburg Drive, Enterprise, AL 36330. Dy: (334) 255-4278. Res: (334) 347-3550. EM: bfordr@snowhill.com. Dy: B Co, 1-212 Avn Regt, Fort Rucker, AL. Rtg: IP. RW Qual. FW Qual.

**Riddle, Mark A.**, (CW3) 205 Susana Drive, Georgetown, TX 78628. Dy: (254) 288-9948. Res: (512) 863-3150. EM: mniddle@ghwn.net. S: Nancy, Dy: Test Plans Officer, Aviation Test Dir, TEXCOM. Rtg: IP. RW Qual. Time: 1,725 Hrs./Cbt 30 AM/1.

**Riley, Christopher**, (CW2) 542nd Med Co (AA), Box 144, Unit 15705, APO AP 96208-0705. EM: criley@soback.komet.nm.kr. S: Mary, Dy: Camp Page, Korea. RW Qual. FW Qual. Time: 600 Hrs.

**Riley, Walter E.**, (CW5) 949 Merlowter Road, Clarksville, TN 37040. Dy: (502) 798-1184. Res: (931) 552-4588. S: Ginger, Dy: F 1-160th SOAR (A), Fort Campbell, KY. Rtg: MAA SIP TP MTP. RW Qual. FW Qual. Time: 5,000 Hrs.

**Rinehart, Steven E.**, (CW4) 502 Pioneer Trail, Harker Heights, TX 76548. Dy: (254) 288-9124. Res: (254) 690-3463. EM: srinehart@saginak.net. S: Anna-Dee, Dy: 507 Medical Co (AA), Fort Hood, TX. Rtg: IFE SIP IP MTP MTFE. RW Qual. Time: 5,500 Hrs.

**Rivas, Mark A.**, (CW2) 3B Kedenburg Court, Fort Benning, GA 31905. Res: (334) 598-1848. EM: mrivas1@juno.com. Dy: DOT Avn, Fort Benning, GA. RW Qual. Time: 500 Hrs.

**Rivers, Patrick L.**, (CW4) (Pat) 162 Lakewood Drive, Daleville, AL 36322. Dy: (334) 255-2755. Res: (334) 598-1248. EM: patrick\_rivers@rucker-emh4.army.mil. Dy: Directorate of Training, Doctrine and Simulation, Fort Rucker, AL. Rtg: MAA. RW Qual. Time: 2,020 Hrs.

**Roberts, Floyd W.**, (CW5) HHC 1st PER-SOC (OPMD), Unit 29058, APO AE 09081. EM: floyd@hq.perscom.heldberg.army.mil. S: Irene, Dy: Aviation Assignment Officer, Heidelberg, Germany. Rtg: MAA MTP. RW Qual. FW Qual. Time: 6,025 Hrs./Cbt 950 AM/18.

**Roberts, Joseph C.**, (CW4) (Joe) 238 Edith Way, Daleville, AL 36322. Res: (334) 598-6145. S: Joy, Dy: 2-52nd Avn Regt, APO AP. Rtg: SIP. RW Qual. Time: 4,300 Hrs.

**Robertson, Patrick M.**, (CW2) 3460 Central Avenue, Roseville, CA 95727. Res: (916) 773-6969. EM: hawkdrvr@hotmail.com. Dy: UH-60 Pilot, Germany. RW Qual. Time: 450 Hrs.

**Robert, Villarreal**, (WO1) (Bob) 32 Boyce, Fort Rucker, AL 36362. Res: (334) 598-6570. S: Susie, Dy: IEWC.

**Rodriguez, John**, (CW3) 17 Johnson Street, Fort Rucker, AL 36362. Dy: (334) 255-9996. Res: (334) 598-6710. S: Pamela, Dy: WOCC Senior Platoon Trainer, B Co, 1/145th Avn. RW Qual. Time: 1,900 Hrs.

**Rodriguez, Jorge A.**, (CW4) (George) M-7



Rio Caguita Street, Rio Hondo I., Bayamon, PR 00061. S: Nancy. Rtg: MAA IP IFE SIP ASO. RW Qual. Time: 4,600 Hrs.

**Rogie, Matthew K., (CW2) (Matt)** 53 E. Harris Drive, Fort Rucker, AL 36362. Dy: (334) 255-5716. Res: (334) 503-1154. EM: mrogle@snowhill.com. Dy: CH-47D SPI/FE, F Co, 1-14th Avn Regt, Fort Rucker, AL Rtg: IFE SIP. RW Qual. Time: 1,750 Hrs.

**Rose, David J., (CW5) CMR 430, Box 1352, APO AE 09096.** S: Freida. Dy: 1st MI Bn, Wiesbaden, Germany. Rtg: MAA ASO. RW Qual. FW Qual. Life Member. Past Chapter Officer.

**Rose, Everett W., (CW3) (Pete)** 1412 Eagle Trail, Coppas Cove, TX 76522. EM: pkruse@al.net. S: Karen. Dy: IPI/FE, CATB. Rtg: IFE IP. RW Qual. Time: 3,600 Hrs.

**Ross, Delors, (CW5) (D)** 99-712 Ewelani Street, Aiea, HI 96701. Dy: (808) 656-2769. Res: (808) 486-7557. EM: rosspwr2@aol.com. S: Patricia. Dy: HHC, Avn Bde 25th ID(L), Bde Tactical Opns Ocltr. Rtg: MAA IFE SIP IP EWQ. RW Qual. Time: 5,100 Hrs./Cbt 800 AM/3. Life Member.

**Rudy, Mark L., (CW3) 125 Tibet Avenue, Apt. 119B, Savannah, GA 31406.** Dy: (912) 352-5500. Res: (912) 961-1139. Rtg: MTP. RW Qual. Time: 1,700 Hrs.

**Russell, Lori J., (CW2) 1208 Kathay Drive, Killeen, TX 76542.** Dy: (817) 288-1034. Res: (817) 634-1695. EM: morepwr@aol.com. Dy: D Trp1/7 Cav, Fort Hood, TX. RW Qual. Time: 350 Hrs.

**Rutledge, Kim D., (CW2) 226 Skyline Drive, Daleville, AL 36322.** Dy: (334) 255-4605. Res: (334) 598-1274. S: Renee. Dy: A Co, 1/21st Avn, Fort Rucker, AL. Rtg: SIP. RW Qual. Time: 1,900 Hrs.

**Sadowski, Joseph L., (CW3) (Joe)** 1243 Springwell Place, Newport News, VA 23608. Dy: (757) 878-2233. Res: (804) 989-0766. Dy: Installation Avn Safety Off, Fort Eustis, VA. Rtg: SAA. RW Qual. Time: 1,200 Hrs.

**Saenz, David S., (CW3) 2008 Woodson Way, Fountain, CO 80817-1661.** Dy: (719) 526-0672. Res: (719) 382-3063. EM: saenzd@cw3.army.mil. S: Maria. Dy: T Trp, 4/3 ACR, Fort Carson, Rtg: MTP. RW Qual. FW Qual. Time: 2,300 Hrs.

**Sall, Walter M., (CW2) (Mike)** 92-1227 Umena Street, Kapolei, HI 96707. Dy: (808) 656-2559. S: Jean. Dy: UH-60 IP, IE, A Co, 2-25th Avn Regt, 25 ID. Rtg: IFE IP. RW Qual. Time: 2,000 Hrs./Cbt 190 AM/1.

**Samuelson, Mark P., (CW5) Townsville, Australia, APO AP 96554.** EM: uncle-sam@proton.net.au. S: Marsha. Dy: CH-47D Exchange Pilot, RAAF Garbutt, Townsville, Australia. Rtg: MAA IP MTP IFE. RW Qual. Time: 4,100 Hrs./Cbt 800 AM/23. Bronze Osm.

**Sandbakken, Joseph W., (CW2) 136 Traynor Avenue, Savannah, GA 31405.** Dy: (912) 352-6259. Res: (912) 353-9987. EM: smokinjoe@mail2.theoncamp.net. S: Veronica. Dy: C Co, 2-3 Avn, Hunter Army Airfield, GA. Rtg: SIP IFE. RW Qual. Time: 2,480 Hrs./Cbt 165 AM/1.

**Sanger, Damon P., (CW3) 4902 Glass Mountain Dr., Killeen, TX 76542.** EM: gun-

pit@aol.com. Dy: A Co, 1-4 Avn, 4ID, Fort Hood, TX. Rtg: AA IP. RW Qual. Time: 2,014 Hrs./Cbt 32 AM/1.

**Sangslund, Rodney L., (CW4) (Sande)** 207th Avn Co, Unit 29231, Box 114, APO AE 09102. S: Diane. Dy: 207th Avn Co, Heidelberg, Germany. Co Stds Officer. Rtg: SIP. RW Qual. Time: 4,000 Hrs./Cbt 40 AM1, IV.

**Santiago, Roberto L., (CW3) 315 Chickasaw Road, Enterprise, AL 36330.** Dy: (334) 255-8531. Res: (334) 393-9236. S: Yolanda. Dy: Army Aviator. Rtg: IP. RW Qual. Time: 2,300 Hrs./Cbt 45 AM/1.

**Sapp, Kent T., (CW3) (Sapper)** 1450 Canoe Creek Drive, S., Colorado Springs, CO 80906. Dy: (719) 540-9856. EM: khsapp@sprintmail.com. S: Heidi. Dy: SIP. S Troop, 4th Squadron, 3d ACR. Rtg: SAA IFE SIP. RW Qual. FW Qual. Time: 2,700 Hrs.

**Sargent, Kenneth H., (CW4) Bavarian Chapter VP Memb, CMR 414 Box 1603, APO AE 09173.** S: Gretchen. Dy: Standardization & Operations Observer/Controller, HHC CMTC Avn Det. Rtg: IFE. RW Qual. Vp, Membership Enrollment, Bavarian Chapter.

**Sawyer, Jimmy R., (CW3) PSC 450, Box 567, APO AP 96206-0567.** EM: eavv1bn-sty@em2nd.korea.army.mil. S: Praphal. Dy: HHC, 1-52nd Avn Bn, Bn Safety Officer. Rtg: ASO. RW Qual. Time: 2,100 Hrs.

**Scheller, Michael L., (CW3) (Mike)** 236th Medical Co, CMR 402, Box 566, APO AE 09180-5000. EM: michael\_scheller@hotmail.com. S: Melissa. Dy: 236th Med Co, Landstuhl, Germany. Rtg: SAA IP. RW Qual. Time: 2,500 Hrs.

**Schmidt, Robert C., (CW5) (Bob)** 290A Alohala Street, Kailua, HI 96734. Dy: (808) 438-9892. Res: (808) 262-2762. EM: schmidr@shafter-emh3.army.mil. S: Debbie. Dy: USA, Pacific ODCSLOG, Aviation Logistics/Aircraft Maint. Officer. Rtg: MAA MTP. RW Qual. FW Qual. Time: 4,000 Hrs.

**Schmitz, Timothy L., (CW2) (T.J.)** 22201 Riverglade Dr, Watertown, NY 13601. Res: (315) 786-8090. S: Pam. Dy: Fort Drum, NY. Rtg: MTP. RW Qual. Time: 900 Hrs. Life Member.

**Scruggs, Jessie P., (CW2) (J.P.)** 2105 Terrace Drive, Copperas Cove, TX 76522. Dy: (254) 288-9758. Res: (254) 518-3144. S: Mark-Kathm. Dy: RC-12D Aviator/ASD. RW Qual. FW Qual. Time: 500 Hrs.

**Sculi, Kenneth T., (CW2) (Ken)** PSC 1, Box 2417, APO AA 34001. Dy: (507) 284-6757. Res: (507) 288-6237. EM: ksculi@panama.com.net. S: Tammy. Dy: C Co, 1-228th Avn, Panama. RW Qual. Time: 850 Hrs./Cbt 52 AM/2.

**Seeds, John A., (CW2) 103 Chickasaw Road, Enterprise, AL 36330.** Dy: (334) 255-5051. Res: (334) 347-2010. Dy: C 1-14 Avn Regt, Fort Rucker, AL. Rtg: IP. RW Qual. Time: 1,500 Hrs.

**Selje, Robert F., (CW2) (Bob)** 1747 Butternut Drive, Clarksville, TN 37042. Dy: (502) 798-2350. S: Barbara. Dy: A Troop, 2-17 Cavalry, Fort Campbell, KY. Rtg: ME. RW Qual. Time: 1,900 Hrs. Life Member.

**Shepard, Glenn A., (CW2) (Shep)** 817C

Hidden Springs Drive, Clarksville, TN 37042. Dy: (502) 798-2746. Res: (931) 553-8354. Dy: A Co, 9/101 Avn Regt, Fort Campbell, KY. RW Qual. Time: 300 Hrs.

**Shin, Young S., (WO1) 217 Apache Drive, Apt. 20A4, Enterprise, AL 36330.** Res: (334) 393-8313. EM: goonbari@awanet.com. Dy: Flight Student.

**Sickmeier, David, (CW4) 608 Gardendale Lane, Clarksville, TN 37040.** Dy: (502) 798-7216. Res: (931) 551-8185. EM: sickmeierd@campbell-emh5.army.mil. S: Janice. Dy: Battalion Safety Officer, 2-101 Avn Regt, Fort Campbell, KY. Rtg: ASO. RW Qual. Time: 1,940 Hrs./Cbt 38 AM/2.

**Simoneau, Terri K., (CW3) 1501 Coolcrest Drive, Colorado Springs, CO 80906-7749.** Dy: (719) 526-0321. Res: (719) 540-9229. EM: litemi@aol.com. Dy: EH-60 Maint Pilot, HHT, 4/3 ACR. Rtg: AA MTP.

**Skaaden, Richard A., (CW4) (Dick)** 2901 Willowbend Dr, Killeen, TX 76543. Dy: (817) 288-1356. Res: (817) 526-5401. S: Bettie. Dy: HHS Co, 15 MI Bn (AE), Fort Hood. Rtg: MAA SIP MTP. RW Qual. FW Qual. Time: 8,000 Hrs./Cbt 1,854 DFC2, AM/39.

**Skaar, Steven R., (WO1) 16 Waal Place, Fort Bragg, NC 28307.** Res: (910) 496-0849. S: Jodi. Dy: C Co, 1-82 Avn, Fort Bragg, NC.

**Smallwood, Gregory T., (CW4) (S-Wood)** 10493 Sagebrush Court, Waldorf, MD 20601. Dy: (301) 981-5040. Res: (301) 932-9338. EM: swood@juno.com. S: Elaine. Dy: C 20 Pilot, USAPAT, Rtg: MAA IP IFE SIP. RW Qual. FW Qual. Time: 4,800 Hrs.

**Smith, Bryan H., (CW4) 204 E. Silver Oak Drive, Harned Creek Estates, Enterprise, AL 36330.** Dy: (334) 255-1230. Res: (334) 347-1762. EM: bryan.smith@rucker-emh4.army.mil. Dy: OH-58D Instructor, Kiowa Warrior Academics Bmch Ch, Fort Rucker, AL. Rtg: MAA IP. RW Qual. Time: 4,000 Hrs./Cbt 110 AM/1.

**Smith, Gary S., (CW4) 1359 Overlook Drive, Sierra Vista, AZ 85605.** Dy: (520) 538-2863. Res: (520) 459-6311. S: Vicki. Dy: B Co, 304th MI Bn, Fort Huachuca, AZ. Rtg: MAA SP ME IE. RW Qual. FW Qual. Time: 4,000 Hrs.

**Smith, Michael E., (CW3) (Mike)** 207H Aviation Company, Unit 29231, Box 43, APO AE 09102. EM: duke14@msn.com. Dy: IP, 207H Aviation Co, Heidelberg, Germany. Rtg: AA IP. RW Qual. Time: 2,000 Hrs./Cbt 95 AM/1.

**Smith, Robert J., (CW2) B Co, 2-1 Avn. Bn, CMR 454, Box 1994, APO AE 09250.** S: Amy. Dy: UH-60 Aviator. RW Qual. Time: 525 Hrs.

**Smolka, John S., (CW4) 830 Old Newton Road, Daleville, AL 36322.** Dy: (334) 255-3029. Res: (334) 598-8342. EM: john\_smolka@rucker-emh4.army.mil. S: Mary Ann. Dy: SPI/FE Cargo Division, Dir of Eval & Stds, SPI/FE Cargo Division, DES. Rtg: MAA IFE SIP. RW Qual. Time: 5,600 Hrs.

**Soltani, James K., (CW2) (Jim)** E Troop, 1-4 Cav, CMR 464, Box 506, APO AE 09226. EM: jsoltani@swfn.baesnet.net. S: Lori. Dy: Warrior Pilot, Schweinfurt, Germany. RW Qual. Time: 800 Hrs.

**Sondag, John P., (CW4) (Jack)** 2256

Williby Court, Morrow, GA 30260. Dy: (404) 362-7217. EM: w4pache@aol.com. Dy: Maintenance Officer, FORSCOM ARMS. Rtg: MTP SAA. RW Qual. Time: 3,000 Hrs./Cbt 80 AM/2.V.

**Speal, Joseph F.**, (CW3) 68 King James Ct, Savannah, GA 31419. Dy: (912) 352-5389. Res: (912) 921-0788. S: Christine. Dy: 1/3 Avn Regt, Hunter AAF, GA. Life Member.

**Stanislav, Duane D.**, (CW3) 650 Ashley Ln, Enterprise, AL 36330. Dy: (334) 255-5056. Res: (334) 393-6601. Dy: AH64 IP, D Co, 1/14th Avn Regt, Fort Rucker, AL. Rtg: SAA IP. RW Qual. Time: 3,200 Hrs./Cbt 6 AM/1.

**Steiner, Michael L.**, (CW2) (Mike) 709 R. S. Bradley, Clarksville, TN 37042. Dy: (502) 798-9370. Res: (931) 552-6056. Dy: UH-60 Pilot, A Co, 5-101 Avn Regt, Fort Campbell, KY. Rtg: AA. RW Qual. Time: 1,400 Hrs.

**Stephens, Steve H.**, (CW4) 350 Fembrook Way, Marietta, GA 30064-1680. Dy: (770) 919-5284. EM: sstephens@sprintmail.com. Dy: FORSCOM Jet Training Detachment, Dobbins Air Reserve Base. Rtg: SAA IP IFE MTP SIP. RW Qual. FW Qual. Time: 4,500 Hrs./Cbt 135 AM/1.

**Stapp, William K.**, (CW5) (Keith) HHC 17th Avn Bde, APO AP 96205-0043. EM: wkst2@bora.dacom.co.kr. S: Melissa. Dy: Bde AMO, Seoul. Rtg: MAA TP. RW Qual. Time: 3,700 Hrs.

**Stevens, Jake H.**, (CW5) 213 Cedar Drive, Enterprise, AL 36330. Dy: (334) 255-9545. Res: (334) 347-3579. EM: jake\_stevens@nicker-emb4.army.mil. S: Pam. Dy: Night Vision Device Branch, Avn Tmg Bde. Rtg: MAA IFE SIP. RW Qual. FW Qual. Time: 11,000 Hrs./Cbt 2,000 AM/48, DFC2.

**Stevenson, Kelli N.**, (CW2) 605 Carbondale Drive, Oak Grove, KY 42262. Dy: (931) 798-2056. Res: (502) 640-0292. Dy: B 9-101 Avn Regt, Fort Campbell, KY. RW Qual. Time: 300 Hrs.

**Stewart, Shannon C.**, (CW2) 139 Lyons Drive, Leesville, LA 71446. Dy: (318) 531-1611. Res: (318) 462-9031. Dy: 153B UH-1H Pilot.

**Stewart, Tammy A.**, (WO1) 603 Melbourne Avenue, Enterprise, AL 36330. Dy: (334) 255-9023. Res: (334) 393-0644. S: Mike. Dy: Flight Student, Fort Rucker, AL.

**Stidole, Jim L.**, (CW2) 708-D Phalen Drive, Coppenhagen, NY 13626. Dy: (315) 752-3910. Res: (315) 888-9436. EM: sstidole@gisconet.s. Melissa. Dy: Aviator, B Co, 1-10 Avn Bde, Fort Drum, NY. RW Qual. FW Qual. Time: 600 Hrs.

**Strine, Jay D.**, (CW3) 4015 Argonaut Place, Great Lakes, IL 60088. Dy: (847) 266-3149. Res: (847) 473-1482. EM: bhawk60@aol.com. S: Elaine. Dy: ASO, Fort Sheridan, IL. Rtg: SAA. RW Qual. Time: 2,400 Hrs./Cbt 46 AM/1.

**Sullivan, John D.**, (CW2) 131 Brian Court, Daleville, AL 36322. Dy: (334) 255-6058. Res: (334) 598-2189. EM: outcast31@aol.com. Dy: AH-64 Instructor Pilot, D Co, 1-14 Aviation Regiment, Rtg: IP. RW Qual. Time: 750 Hrs. AM/2.

**Sullo, Fred K.**, (WO1) 209 Christopher Drive, Enterprise, AL 36330. Dy: (334)

393-8568. Res: (334) 393-9568. EM: shady17@aol.com. S: Elizabeth. Dy: B-1-145 Avn Regt, Fort Rucker, AL. Time: 600 Hrs.

**Sunderlin, Terry C.**, (CW3) (Sundy) 206 Christopher Drive, Enterprise, AL 36330. Res: (334) 393-4930. EM: sunderlinzoo@pobox.com. S: Rebecca. Dy: Instructor Pilot, D Co, 228th Avn Regt, Soto Can, Honduras. Rtg: IP. RW Qual. FW Qual. Time: 2,500 Hrs./Cbt 50 AM/1, DFC1.

**Swaim, Howard L.**, (CW5) 6851 Todd St, Fort Hood, TX 76544-1332. Dy: (254) 287-8590. Res: (254) 539-7471. EM: swaimh@hood-emb3.army.mil. S: Lizette. Dy: III Corps Stds Br, HCP III Corps & Fort Hood. Rtg: SP IFE. RW Qual. Time: 6,500 Hrs. Bronze Osm.

**Swanberg, D. Erick**, (CW2) 37 Logan Street, Fort Rucker, AL 36362. Dy: (334) 255-8513. Res: (334) 503-1046. S: Teresa. Dy: HHC 1-223d, Fort Rucker, AL. Rtg: ASE EWO IP. RW Qual. Time: 1,000 Hrs.

**Sweet, Dennis R Jr.**, (CW2) 109 Silver Lane, Azle, TX 76020. Res: (817) 237-6026. Dy: Korea. RW Qual. Time: 1,200 Hrs. Life Member.

**Swickard, Jeffrey M.**, (CW5) (Jeff) 411 Navaho Drive, Enterprise, AL 36330. Dy: (334) 255-3258. Res: (334) 398-2696. S: Todd. Dy: ATC Stand. Off, USAATCA, Fort Rucker, AL. Rtg: MAA IFE SIP. RW Qual. FW Qual. Time: 7,300 Hrs./Cbt 660 AM/19. Past Chapter Officer.

**Szad, Charles R.**, (CW3) (Chuck) 37 Red Cloud Road, Fort Rucker, AL 36362. Dy: (334) 255-5055. Res: (334) 598-1116. EM: flygunz@snowhill.com. S: Glenda. Dy: D Co, 1-14th Avn, Fort Rucker, AL. Rtg: IP. RW Qual. Time: 2,000 Hrs. Past Chapter Officer.

**Tablerius, Brett A.**, (WO1) (Tab) CMR 3, Box 7141, Fort Rucker, AL 36362. Res: (334) 503-1390. EM: btat@snowhill.com. Dy: B Co, 1/145th.

**Taddeo, Peter J.**, (WO1) 709 RS Bradley Blvd., Clarksville, TN 37042. Dy: (502) 798-4444. Res: (931) 552-6056. Dy: B Co, 5/101 Avn Regt, Fort Campbell, KY. RW Qual. Time: 300 Hrs.

**Tague, Eric J.**, (WO1) 203 Oriole Drive, Enterprise, AL 36330. Res: (334) 393-3367. EM: eric@tague.com. Dy: B Co, 1-145 Avn. Time: 59 Hrs.

**Taylor, Mark H.**, (CW3) 94-025 Puanane Place, Milliani, HI 96789-1758. Dy: (808) 656-9890. Res: (808) 623-9897. Dy: IP, B Co, 1/25 Avn Regt, WAAF, HI. Rtg: IFE. IP. RW Qual.

**Templeton, Daniel E.**, (CW2) (Dan) 6 Meadow Drive, Daleville, AL 36322-9460. Dy: (334) 255-5055. Res: (334) 598-5573. S: Lorraine. Dy: D Co, 1/14th Avn Regt, Fort Rucker, AL. RW Qual. FW Qual. Time: 1,000 Hrs.

**Terry, Mark D.**, (CW4) (Doc) 2632 Forest Way, Marietta, GA 30068-1491. Res: (770) 517-3815. S: Tara. Dy: Cessna Citation Ultra (UC-35) Pilot, Atlanta, GA. Rtg: MAA SIP. RW Qual. FW Qual. Time: 5,100 Hrs. AM/7. Past Chapter Officer.

**Thomas, Rodney M.**, (CW5) (Rod) 113

Agnes Lane, Ozark, AL 36360. Dy: (334) 255-6895. S: Jenelle. Dy: USAARL, ASO, Fort Rucker, AL. Rtg: MAA IP SIP. RW Qual. Time: 6,100 Hrs. Past Chapter Officer.

**Thompson, Mitchell G.**, (CW5) (Glenn) HHC, Aviation Brigade, Unit 15435 Box 58, APO AP 96257-0481. EM: thompsonmg@usfk.korea.army.mil. S: Frances. Dy: Standardization Officer, Avn Bde 21D, Camp Stanley, Korea. Rtg: SIP. RW Qual. Time: 4,500 Hrs./Cbt 25 AM/1. Vp, Chapter Awards, Morning Calm Chapter. Bronze Osm.

**Thompson, Robert H.**, (CW4) (Not Bob) 27676 Crestview, Barstow, CA 92311. Dy: (760) 380-3048. Res: (760) 252-3944. S: Lesley. Dy: UH-60 Instructor Pilot, 247th Med Det. (RA) Ft. Irwin, CA. Rtg: MAA SIP. RW Qual. Time: 3,900 Hrs.

**Thomsen, Gregory G.**, (WO1) (Greg) 28 Red Cloud Road, Fort Rucker, AL 36362. Dy: (334) 255-9730. Res: (334) 503-1356. S: Clarissa. Dy: B Co, 1-145th, Fort Rucker, AL.

**Timmons, Stephen A.**, (CW4) 28 Clover Hill Drive, Stafford, VA 22554. Dy: (703) 806-7622. Res: (540) 752-7288. EM: stmm57@aol.com. S: Angela. Dy: 12th Aviation Battalion, Fort Belvoir, VA. Rtg: IP SIP IFE. RW Qual. Time: 3,300 Hrs./Cbt 75 AM/2.

**Tompkins, William R.**, (CW4) (Thumper) 501 Wildwood Drive, Enterprise, AL 36330. Dy: (602) 891-3229. Res: (334) 393-0030. S: Donna. Dy: AH-64 D SIFPIE, A Co, 1-14th Avn Regt, Mesa, AZ. Rtg: MAA IFE SIP. RW Qual. Time: 3,900 Hrs./Cbt 50 AM/2.

**Trigger, Michael E.**, (CW4) (Mike) 15860 Montview Drive, Dunfries, VA 22026-1313. Dy: (703) 325-5228. S: Karen. Dy: PERSCOM, Alexandria, VA. Rtg: SP IFE MTP ME IFE. RW Qual. Time: 3,000 Hrs.

**Tronnes, Steven J.**, (CW4) HHD 7-159 Avn Regt, CMR 416, Box 1611, APO AE 09140. EM: tronnes@email1.ansbach.army.mil. S: Teresa. Dy: Maintenance Officer, Illesheim, Germany. Rtg: MAA MTP. RW Qual. Time: 4,200 Hrs./Cbt 50 AM/1. Life Member.

**Tucker, William E.**, (CW5) (Wild99) HHC, 11th Avn Regt, CMR 416, Box 1062, APO AE 09140. EM: 11avnstan@email.ansbach.army.mil. S: Doris. Dy: Aviation Stds. Rtg: SIP. RW Qual. FW Qual. Time: 7,500 Hrs./Cbt 869 DFC1, AM23. Other., Talon Chapter.

**Tutin, Lee M.**, (CW3) 9906-B Gates Street, Fort Drum, NY 13603. Dy: (315) 772-3267. Res: (315) 773-6735. S: Robin. Dy: Sqdn Stds, HQs 317 Cavalry, Fort Drum, NY. Rtg: SAA IFE. RW Qual. Time: 3,800 Hrs. Past Chapter Officer.

**Underhill, Ronald L.**, (CW4) (Ron) 207th Avn Co, Unit 29231, Box 156, APO AE 09102. S: Terry. Dy: IP/Safety Officer. Rtg: MAA IP. RW Qual. Time: 3,500 Hrs.

**Vahey, Mark A.**, (CW2) 3507 East Ridge Road, Woodlawn, TN 37191. Res: (931) 906-0810. EM: mvahay@compuserve.com. S: Joette. Dy: UH-60 Blackhawk Pilot, Fort Campbell, KY. RW Qual. Time: 1,200 Hrs.

**Vanalmsick, William L.**, (CW4) 502 Aspen Drive, Clarksville, TN 37042. Dy: (502)

798-3147. Res: (931) 645-9418. Dy: Standardization Officer, 5th Bn, 101st Avn Regt. Rtg: MAA SIP IFE. RW Qual. Time: 4,000 Hrs./Cbt 150 AM/2.

**Van Den Eng, Bruce C.**, (CW3) Central American VP Prog, PSC 4, Box 802, APO AA 34004. Dy: (507) 284-4942. Res: (507) 288-5484. S: Sue Ann. Dy: Safety Officer, CH47D Pilot. Rtg: ASO. RW Qual. Time: 1,300 Hrs./Cbt 117 AM/2. Vp, Programs, Central American Chapter.

**Vandenbergh, John E.**, (CW4) (Duck) 113 White Stone Court, Newport News, VA 23603. Dy: (757) 878-5479. Res: (757) 888-1619. S: Mary. Dy: Experimental Test Pilot, AATD FEVA. Rtg: MAA XP SIP MTP. RW Qual. RW Qual. Time: 2,800 Hrs./Cbt 60 AM/1. Past Chapter Officer.

**Vanderberg, Brian W.**, (WO1) 1129 Franklin Street, Watertown, NY 13601. Dy: (315) 772-3801. Res: (315) 779-2261. EM: wotvbdb@aol.com. S: Krista. Dy: A/1-10 Avn (Attack), Fort Drum, NY. Rtg: AA, RW Qual. FW Qual. Time: 500 Hrs.

**Van Etten, Ben A.**, (CW5) 1704 Buck Creek Court, Fayetteville, NC 28304. Dy: (910) 896-8600. Res: (910) 420-0564. EM: vanette6@gragg.army.mil. S: Linda. Dy: ALMD, 4/159 AMB, Fort Bragg, NC. Rtg: MAA ME. RW Qual. FW Qual. Time: 12,980 Hrs./Cbt 948 AM29,2V,DFC1. Past Chapter Officer.

**Van Keuren, Nathan B.**, (CW5) (Nate) 1260 W. Mesquite Street, Chandler, AZ 85224. Dy: (602) 891-3506. Res: (602) 917-4453. EM: nvankeuren@phrao.dcmd.dla.mil. Dy: DCMC-Boeing-Mesa, Chief of Ft Ops. Rtg: MAA MTP. RW Qual. Time: 4,000 Hrs./Cbt 700 DFC1, AM27. Past Chapter Officer.

**Vines Jr., Dumas J.**, (CW4) (Jim) 100 Rainbow Avenue, Fort Benning, GA 31905-6536. Dy: (706) 545-8086. Res: (706) 687-3081. EM: dvines@juno.com. S: Deborah. Dy: Chief, Flight Support Branch, Fort Benning, GA. Rtg: MAA. RW Qual. Time: 4,000 Hrs. Life Member.

**Voight, Raleigh L.**, (CW5) Aloha Chapter Secretary, 502 Morris Road, Wahiawa, HI 96786. Dy: (808) 656-2195. Res: (808) 624-8836. EM: amoavn@schofield-emh1.army.mil. S: Eleanor. Dy: Aviation Maintenance Officer. Rtg: MTP. RW Qual. Time: 4,100 Hrs./Cbt 1,005 AM/32. Secretary, Aloha Chapter.

**Voisine, Joel J.**, (CW5) 9213 Cutting Horse Court, Springfield, VA 22153-1018. Dy: (703) 695-9471. Res: (703) 913-1798. EM: voisinjj@hqsda.army.mil. S: Kim. Dy: WO Policy Integrator, Dep Chief of Staff, Personnel. Rtg: MAA IFE SIP. RW Qual. FW Qual. Time: 4,000 Hrs.

**Waesrch, Wayne A.**, (CW5) (Wayne) 842 Greystone Terrace, Newport News, VA 23602. Dy: (757) 878-4564. Res: (757) 833-6170. EM: waeschw@eustis-emh10.army.mil. Dy: Director, Dept. of Attack Helicopter Trng, Fort Eustis, VA. Rtg: SAA TP IP ME. RW Qual. Time: 2,800 Hrs./Cbt 300 AM/12.V. Past Chapter Officer.

**Wagner, Robert M.**, (WO1) 3105 Achey Drive, Enterprise, AL 36330. Res: (334)

393-4114. EM: rwagner@snowhill.com. Dy: B Co, 1/145th Avn.

**Wagner, Timothy S.**, (CW2) D Troop, 1-1 Cav, CMR 401, Box 470, APO AE 09076. Dy: (817) 288-3812. EM: wago58d@iwi.com.de. S: Kelli. Dy: OH-58D Pilot, Buedingen, Germany. RW Qual.

**Walte, Robert A.**, (CW3) (Bob) 78th Aviation BN (P), Box 17, APO AP 96338-5007. EM: rwalte@zam01.attnet.or.jp. S: Barb. Dy: UH-60 IFE, Camp Zama, Japan. Rtg: IFE SIP. RW Qual. Time: 2,500 Hrs. AM/2. Vp, Chapter Awards, Rising Sun Chapter.

**Walker, Wayne K.**, (CW4) (W.T.F.) Phantom Corps VP Memb., Rt. 2 Box 29C, Killeen, TX 76542. Dy: (254) 287-7699. Res: (254) 554-8089. EM: wwalker@balista.com. S: Melva. Dy: Bn Safety Officer, TSB Riley, Fort Hood, TX. Rtg: MAA ASO. RW Qual. Time: 6,000 Hrs. Vp, Membership Enrollment, Phantom Corps Chapter, Past Chapter Officer.

**Wallace, Charles N.**, (CW3) (Chip) 1058 Desert Shield St, Hinesville, GA 31313. Dy: (912) 767-4475. Res: (912) 369-8548. EM: chipwall@aal.com. S: Stephanie. Dy: E Top, 3-7 Cavalry, Fort Stewart, GA. Rtg: SAA MTP. RW Qual. Time: 1,750 Hrs./Cbt 120 AM/2.

**Walsh, Joseph**, (CW4) (Joe) HHC, 1705 Avn Bde, Unit 15270, APO AP 96205. EM: eav-st2@emh2.korea.army.mil. S: Marilyn. Dy: Brigade Standardization Officer, Yongson, Korea. Rtg: MAA IFE SIP. RW Qual. Time: 6,100 Hrs./Cbt 80 AM/4.

**Walshingham, Joseph R.**, (CW3/P) (Joe) EUCOM Ft Det, CMR 423, Box 599, APO AE 09107. EM: jwalshingham@comuserve.com. S: LaDonna. Dy: C-12 SIP, EUCOM HQ, Stuttgart, Germany, Standardization Officer. Rtg: SAA SIP. RW Qual. FW Qual. Time: 5,400 Hrs. AM/1.

**Ward, Harry R.**, (CW5) (Buzz) P.O. Box 755, APO AP 96508. Dy: (907) 873-4171. Res: (907) 869-3268. EM: apvrgv1@richardson-emh2.army.mil. S: Patricia. Dy: Commander, USAG Aviation Detachment, Fort Greely, AK. Rtg: MAA IFE SIP. RW Qual. Time: 6,950 Hrs./Cbt 863 Past Chapter Officer.

**Wargowsky, Robert L.**, (CW3) (Bob) 3342 Tara Blvd., Clarksville, TN 37042. Res: (931) 503-0783. EM: bobwargo@juno.com. S: Catherine. Dy: D Co, 1/160th SOAR, Fort Campbell, KY. Rtg: SAA IP IFE EWO. RW Qual. Time: 4,000 Hrs.

**Warlick, Mike**, (CW4) (Mike) P.O. Box 8095, San Antonio, TX 78208. Dy: (210) 211-9749. Dy: Standardization Officer, 5th Army AFMS Team (A). Rtg: SIP IFE. RW Qual. Time: 6,500 Hrs./Cbt 930 AM/26.

**Warren, Johnny H.**, (CW4) 2703 Reed Lane, Killeen, TX 76542. Dy: (254) 288-9087. EM: warrenj@hood.army.mil. Dy: AH-64D SPRIE Master Gunner, HHC, 1-227, Fort Hood, TX. Rtg: MAA SIP IFE. RW Qual. Time: 3,000 Hrs./Cbt 80 AM/2.V.

**Webb, Kendall L.**, (CW4) (Kenny) 1158A New Drennan Park, Fort Campbell, KY 42223. Dy: (502) 798-1308. Res: (615) 431-2009. S: Barbara. Dy: 1-160th SOAR (A)

Bn ASO. Rtg: MAA ASO. RW Qual. Time: 4,400 Hrs./Cbt 260 AM/2.

**Webb, William C.**, (CW4) (Bill) EUCOM Ft Det, Unit 30400, Box 787, APO AE 09128. Res: (334) 692-3762. EM: wwebb2@comuserve.com. S: Judy. Dy: Instructor Pilot, Stuttgart, Germany. Rtg: SAA IP IFE. RW Qual. FW Qual. Time: 3,950 Hrs.

**Weber, Major E.**, (CW5) P.O. Box 3052, Arlington, VA 22203. Dy: (703) 607-9760. Res: (703) 892-1399. EM: webemaj@ngb-amg.ngb.army.mil. S: Rosalie. Dy: Aviation Current Operations. Rtg: MAA. RW Qual. Time: 4,800 Hrs./Cbt 960 AM/25.

**Webster, Clayton C.**, (CW3) CMR 408, Box 331, APO AE 09182. S: Maria. Dy: CH-47D IP, A Co, 5/159th Avn. Rtg: IFE IP. RW Qual. Time: 2,000 Hrs./Cbt 200 AM/1.

**Weigart, Michael D.**, (CW2) 1023 Haggard Drive, Clarksville, TN 37043. Dy: (502) 798-4738. Res: (931) 905-1659. S: Michele. Dy: C Co, 6/101st Avn Regt, Fort Campbell, KY. Rtg: AA. RW Qual. Time: 1,000 Hrs. Past Chapter Officer.

**Weigel, Fred K.**, (CW2) 2364 F Gemini Avenue, Honolulu, HI 96818. Dy: (808) 656-1210. Res: (808) 422-2872. EM: aweosome@hls.net. S: Elissa. Dy: C Co, 2-25th Aviation Regiment, Wheeler Army Airfield, HI. RW Qual. Time: 800 Hrs. Past Chapter Officer.

**Weinhold, Robert C.**, (CW3) 409 Coby Drive, Ozark, AL 36360-6231. Dy: (334) 255-4044. S: Penny. Dy: E Co, 1-212th Avn Regt, Fort Rucker, AL. Rtg: SAA IP. RW Qual. Time: 2,500 Hrs./Cbt 60 AM/1.

**Wellington, Jeff R.**, (WO1) (Duke) P.O. Box 620536, Fort Rucker, AL 36362. Dy: (334) 255-9730. Res: (334) 598-5088. Dy: 2-101st Avn, Fort Campbell, KY. Rtg: AA. RW Qual. Time: 200 Hrs./Cbt 85 AM/2.V.

**Wells, Allen R.**, (CW4) (Randy) 30 Kirby Street, Fort Rucker, AL 36362. Dy: (334) 255-8167. Res: (334) 598-1617. S: Bobbi. Dy: Experimental Test Pilot, ATTC. Rtg: SAA IP TP MTP. RW Qual. FW Qual. Time: 4,000 Hrs./Cbt 20 AM/1.

**Whately, Robert J.**, (CW5) (Bob) 10008 Rodeo Dr, Waco, TX 76712-8349. Dy: (254) 288-3575. Res: (817) 666-1606. EM: whatelyr@hood-emh3.army.mil. S: Joyce. Dy: Brigade Standardization Officer, AH-64D, 21st Cav Bde, Fort Hood, TX. Rtg: MAA SIP MTP. RW Qual. Time: 4,500 Hrs. Bronze Osm.

**White, David L.**, (CW2) (Dave) BKAD 2-501 Avn Regt, CMR 438, Box 1346, APO AE 09111-5000. EM: tadadl@hq.tad.army.mil. S: Dongsoon. Dy: UH-60 IP, Bosnia & Bad Kreuznach, Germany. Rtg: AA. RW Qual. Time: 2,000 Hrs.

**White, Dennis E.**, (CW5) HSC 3rd MI Bn (AE), Unit 15220, Box 1124, APO AP 96271-0156. EM: whited@humpshpreys3501m.korea.army.mil. S: Sandra. Dy: Avn Safety Officer. Rtg: MAA. RW Qual. FW Qual. Time: 8,300 Hrs./Cbt 735 DFC2, AM/31.

**White, Rushton D.**, (CW4) (Russ) Apache Taft, Unit 64901, Box 18, APO AE 09839-4901. EM: rushtonwh@aol.com. S:

Chong, Dy: Egyptian Apache TAFT, Abu Hamad, Egypt. Rtg: AA.

**Whitehead, Eric J.**, (WO1) 71 North Harris Drive, Fort Rucker, AL 36362. Dy: (334) 255-9144. Res: (334) 598-2602. S: Christine. Dy: IEFW Training, B Co, 1-145 Avn Regt, Fort Rucker, AL. Rtg: SP. Time: 110 Hrs.

**Wickenhagen, Ryan P.**, (WO1) 77 Harris Drive, Fort Rucker, AL 36362. Dy: (334) 255-2039. Res: (334) 598-8718. S: Holly. Dy: B Co, 1-145th Avn.

**Wiedemann, David E.**, (CW4) 204 Aaron Drive, Enterprise, AL 36330. Dy: (334) 255-5089. Res: (334) 308-2785. S: Adaline. Dy: C 1-14th Avn, Fort Rucker, AL. Rtg: MAA IFE IP. RW Qual. Time: 4,000 Hrs./Cbt 50 AM3.

**Wiegand, Gary S.**, (CW4) D Co, 1-1 Avn Regt, CMR 454, Box 2005, APO AE 09250. S: Cynthia. Dy: Battalion Maintenance Officer. Rtg: MAA MTP. RW Qual. Time: 2,000 Hrs.

**Williams, Dennis R.**, (CW5) P.O. Box 4097, Fort Eustis, VA 23604. Dy: (757) 878-6660. S: Joy. Dy: Chief Nav Systems USAALS.

**Williams, James E.**, (CW2) (Jim) Route 1, Box 395-A, Clintwood, VA 24228. Res: (540) 835-9750. EM: jimwilliams8@hotmail.com. S: De Anna. Dy: 377th Medical Company, Camp Humphreys, Korea. RW Qual. Time: 900 Hrs.

**Williamse, Mary E.**, (CW4) 3009 Bramblewood Court, Waldorf, MD 20603. Dy: (301) 991-7887. Res: (301) 932-4847. EM: skyn@aol.com. Dy: USAPAT, Andrews AFB, MD. Rtg: MAA ASO. RW Qual. FW Qual. Time: 5,200 Hrs. Life Member. Past Chapter Officer.

**Williams, Richard L.**, (CW5) (Dick) 906 Mill Court, Savannah, GA 31419. Dy: (912) 352-5940. Res: (912) 925-8497. EM: williamsr2@emhs.stewart.army.mil. S: Laine. Dy: HHC Avn Bde/Avn Safety Officer, 3 ID, HAAF. Rtg: SIP. RW Qual. Time: 5,000 Hrs./Cbt 400 AM7, IV. Past Chapter Officer. 83 Molelian Award.

**Williams, Robert L.**, (CW5) (Bob) 306 Arrow Head Drive, Enterprise, AL 36330. Dy: (334) 255-2388. Res: (334) 393-5137. S: Joan. Dy: Avn Branch Safety Officer. Rtg: MAA IFE SIP. RW Qual. FW Qual. Time: 6,100 Hrs./Cbt 1,300 AM30. Life Member.

**Willman, James L.**, (CW5) 111 Wigmore Court, Savannah, GA 31410. Dy: (912) 352-6956. Res: (912) 897-3668. EM: willj47@aol.com. S: Carol. Dy: 3/16th OYAR, Hunter Army Airfield, GA. Rtg: IP MTP. RW Qual. Time: 3,500 Hrs.

**Wilson, Chris**, (CW2) 129 Vollum Road, Sackets Harbor, NY 13685. Dy: (315) 672-3810. EM: cwilsona@juno.com. Dy: B Co 1-1 Avn Regt. Time: 300 Hrs.

**Wilson, John H.**, (CW4) (Jack) 249 Coronado Lane, Sierra Vista, AZ 85635. Dy: (520) 538-9830. Res: (520) 459-6979. EM: jackwilson@theriver.com. S: Sun Hul. Dy: Standardization Officer (JAW), D Co, 304th MI Bn. Rtg: MAA. RW Qual. FW Qual. Time: 7,200 Hrs.

**Wilson, Ronda L.**, (WO1) 4400 Rucker Boulevard, Apt. 6B, Enterprise, AL 36330.

Res: (334) 347-7079.

**Wilson, Thomas G.**, (CW3) (Tom) 413 Warren Circle, Clarksville, TN 37040. Dy: (502) 799-2952. Res: (931) 648-1035. S: Judy. Dy: Instructor Pilot, B Co, 6 Bn, 101 Avn Bde. Rtg: SAA IP IFE. RW Qual. Time: 3,300 Hrs./Cbt 40 AM2.

**Wineland, Jeffrey A.**, (CW4) 1904 Claymont Drive, Clarksville, TN 37040. Dy: (502) 798-2029. Res: (931) 551-3213. S: Chris. Dy: Brigade AH-64 SP, 101st Avn Bde, Fort Campbell, KY. Rtg: MAA IFE SIP. RW Qual. Time: 3,400 Hrs./Cbt 20 AM2.

**Wise, James F.**, (CW5) (Jim) 2009 Penrose Drive, Fayetteville, NC 28304. Dy: (910) 396-3303. Res: (910) 487-5603. EM: jifw@aol.com. S: Julia. Dy: C Co, 2228th Avn Regt. Rtg: MAA IFE SIP. RW Qual. FW Qual. Time: 6,400 Hrs./Cbt 365 AM8. Past Chapter Officer.

**Wittstrom, Joseph L.**, (CW5) (Joe) P.O. Box 22375, Huntsville, AL 35814-2375. S: Lily. Dy: Command Safety Officer. Rtg: MAA IFE SIP IP MTP. RW Qual. FW Qual. Time: 9,260 Hrs. Vp, Membership Enrollment, Tennessee Valley Chapter.

**Wojtala, Thomas J.**, (CW3) (Tom) 820 Cedar Ridge, Harker Heights, TX 76548. Dy: (817) 288-1034. Res: (817) 542-4375. EM: tfojw@centraltx.net. S: Felicia. Dy: D1-7 Cav, Fort Hood. Rtg: SAA MTP. RW Qual. Time: 1,600 Hrs. Life Member.

**Woffard, James C.**, (CW5) 2230 Sapphire Oak, San Antonio, TX 78232. Dy: (210) 221-0804. Res: (210) 545-0433. S: Peggy. Dy: Standardization Officer, HQ, 5th Army. Rtg: MAA IFE SIP. RW Qual.

**Wood, Gregory A.**, (CW3) (Greg) 45 East Harris Drive, Fort Rucker, AL 36362. Dy: (334) 255-4657. Res: (334) 598-1691. EM: gregd@b@snwhill.com. S: Deborah. Dy: HHC, 1-212th Avn. Rtg: SAA ASO. RW Qual. Time: 3,300 Hrs.

**Wood, Laura J.**, (CW2) 6260 Eagle Point Main St., Belton, TX 76513-4818. Dy: (254) 287-2592. Res: (254) 939-6707. Dy: 21st Cav Bde, Fort Hood, TX. Rtg: IP IFE IE. RW Qual. Time: 2,200 Hrs.

**Woodbury, Alden D.**, (CW4) (Woody) 7642 Spurge Drive, Fayetteville, NC 28311. Res: (919) 488-8140. S: Barbara. Dy: A Co, 6-52nd Avn Bn, K-16, Seoul, Korea. Rtg: MAA IFE SIP MTP ME. RW Qual. FW Qual. Time: 6,000 Hrs. Life Member.

**Woodburn, Steve M.**, (CW2) 40 Gall Lane, Fort Rucker, AL 36362. Res: (334) 503-9488. EM: woodburns@usfk.korea.army.mil. S: Susan. Dy: OH-58D Pilot, D Tpt, 4-7 Air Cav, APO AP. RW Qual. Time: 400 Hrs.

**Woodfin, Steven W.**, (CW3) CMR 477, Box 1565, APO AE 09165. EM: srsd@compuserve.com. S: Sandra. Dy: C2-501st Avn, Hanau, Germany. Rtg: IFE SIP. RW Qual. Time: 3,000 Hrs.

**Woods, Stephen L.**, (CW4) (Steve) 16 Johnson Street, Fort Rucker, AL 36362-2232. Dy: (334) 255-1861. Res: (334) 598-0054. EM: steve\_woods@rucker-emh4.army.mil. S: Jenean. Dy: Aviation Electronic Combat Team Leader, DOTDS, Fort Rucker. Rtg: SAA IP. RW Qual. Time:

2,200 Hrs./Cbt 50 AM2, IV. Past Chapter Officer. 90 Aaaa Ase Award.

**Worling, John L.**, (CW3) R. 4/2 ACR, OJG, Comanche Base, APO AE 09879. Dy: Standardization Officer. Rtg: IFE SIP. RW Qual. Time: 3,000 Hrs.

**Worstell, Barry A.**, (CW4) (Baz) D Co, 158th Avn Regt, CMR 408, Box 1007, APO AE 09182. EM: baz58@aol.com. S: Maria. Dy: Standardization Officer, D/158th Avn Regt, Giebelstadt, Germany. Rtg: IFE. RW Qual. Time: 4,375 Hrs./Cbt 10 AM2.

**Wright, John David**, (CW4) (J.W.) 7314-B North Barker Cir., Fort Campbell, KY 42223-3200. Dy: (931) 398-3939. Res: (931) 431-6314. S: Connie. Dy: Bde. W.O. Manager, HHC, 101 Avn Bde. Rtg: MAA SIP IFE. RW Qual. Time: 4,200 Hrs.

**Wright, Kenneth W.**, (CW3) (Ken) 1361 W. Rhett Butler Road, Clarksville, TN 37042. Dy: (502) 798-1452. S: Donna. Dy: B Co, 1/160th SOAR, Fort Campbell, KY. Rtg: IP MTP. RW Qual. Time: 2,700 Hrs. AM3.

**Wright, William D.**, (CW4) (Don) 421st Med Evac Bn, CMR 467, Box 4158, APO AE 09096. EM: wrightd@community.wiesbaden.army.mil. Dy: Bn Safety Officer, Wiesbaden, Germany. Rtg: SAA IP. RW Qual. Time: 10,800 Hrs.

**Young, P. J.**, (CW4) (P.J.) 642 Sperry Loop, Wahiaua, HI 96786. Dy: (808) 856-0811. Res: (808) 624-2891. EM: pjyoung@8@aol.com. Dy: SPI/E. Rtg: IFE SIP. RW Qual. Time: 3,100 Hrs.

**Young, William L.**, (CW5) (Bill) 504 Hemingway Drive, Hockessin, DE 19707. Dy: (610) 591-7275. Res: (302) 234-6588. EM: bre2653@pebxoeng.dorb.af.mil. S: Cathy. Dy: DCMC Boeing Helicopters, Philadelphia, PA. Rtg: MAA MTP. RW Qual. Time: 3,400 Hrs./Cbt 30 AM1.

**Zamudio, Luis**, (CW4) (Z) 7551 S Samardart Ct, Tucson, AZ 85747. Dy: (520) 538-2873. Res: (520) 574-8519. EM: tzamudio@sisa.com. S: Lisa-Anne. Dy: Avn Safety Officer, 304th MI Bn, Fort Huachuca, AZ. Rtg: MAA. RW Qual. FW Qual. Time: 5,000 Hrs. Past Chapter Officer. Bronze Osm.

**Zanders, Michael R.**, (CW2) (Z-Man) 7046 Calamar Drive, Fayetteville, NC 28314. Dy: (910) 396-7816. Res: (910) 868-1964. S: Patricia. Dy: C Co, 1-82nd Avn Bn, Fort Bragg, NC. RW Qual. Time: 400 Hrs.

**Zbrak, Seth B.**, (WO1) 146 Woodfield Place, Enterprise, AL 36330. Res: (334) 308-2042. EM: stzbrak@snowhill.com. Dy: Student Pilot.

**Zimmerman, John M.**, (CW4) (Zimmo) Colonial Va, VP WO Afs, 68 Sandra Drive, Newport News, VA 23608. Dy: (757) 878-4404. Res: (757) 877-9704. EM: jrmzmx@aol.com. S: Joyce. Dy: Chief, Aircraft Armament Division, Fort Eustis, VA. Rtg: MAA IP SIP MTP. RW Qual. Time: 2,600 Hrs./Cbt 30 AM2. Vp, Wo Affairs, Colonial Virginia Chapter.

**Zirpolo, Gale E.**, (CW4) (Bluch) 7200 36th Ct. SE, Lacey, WA 98503. EM: ch47mp@net.att.co.kr. S: Sissy. Dy: B Co, 2/52 Avn Regt, Korea. Rtg: MTP. RW Qual. Time: 2,050 Hrs.

## HIGH TIMERS

CW5 Ben A. Van Etten	12,980	CW5 Greg Reese	6,900	CW4 James N. Hutchens	5,650
CW5 Stephen L. Davidson	11,120	CW5 Reid D. Feltmate	6,700	CW4 Donald G. Andera	5,600
CW5 Thomas J. Magnan	11,000	CW5 Richard G. Johnson	6,600	CW4 Donald T. Braun	5,600
CW5 Jake H. Stevens	11,000	CW4 Ronald K. Moody	6,600	CW5 Peter R. Burnett	5,600
CW4 William D. Wright	10,800	CW4 Edward S. Penick	6,600	CW4 Stanley A. Kennedy, Jr.	5,600
CW5 Robert J. Hawkins	9,430	CW5 Jack H. Dotterer	6,500	CW4 John S. Smolka	5,600
CW5 Joseph L. Wittstrom	9,260	CW5 Howard L. Swaim	6,500	CW3 Neil S. Cadwell	5,500
CW5 Randolph W. Jones	9,000	CW4 Mike Warlick	6,500	CW5 Robert A. Mason	5,500
CW4 Billy F. Fletcher	8,896	CW5 James F. Wise	6,400	CW4 Clay A. Mau	5,500
CW5 Peter R. Kalogris	8,500	CW4 George B. Hendershot	6,350	CW5 Ed R. Mayers, Jr.	5,500
CW5 Dennis E. White	8,300	CW5 Sandra L. Beebe	6,200	CW4 Steven E. Rinehart	5,500
CW5 Robert D. Hill	8,200	CW4 William A. Church	6,200	CW3(P) Joseph R. Walsingham	5,400
CW5 Lance V. McElhiney	8,048	CW5 Rodney M. Thomas	6,100	CW4 Jacob M. Howard	5,300
CW4 Richard A. Skaarden	8,000	CW4 Joseph Walsh	6,100	CW4 Sargent B. Means	5,300
CW4 Howard H. Fancher	7,800	CW5 Robert L. Williams	6,100	CW5 James A. Mankie	5,250
CW5 Michael J. Hutson	7,800	CW5 Floyd W. Roberts	6,025	CW5 Douglas W. Gjerston	5,200
CW5 Jonathan R. Edwards	7,700	CW5 Thomas E. Connell	6,017	CW5 Robert S. Johnson	5,200
CW4 John H. Wilson III	7,700	CW5 Clifford L. Brown	6,000	CW5 Michael T. Moorehead	5,200
CW4 John S. Mollenberry	7,500	CW5 Dean R. Coder	6,000	CW4 Michael S. Olin	5,200
CW5 Richard B. Osterlund	7,500	CW5 Kenneth A. Donahue	6,000	CW5 John L. Peterson	5,200
CW5 William E. Tucker	7,500	CW5 Leon A. Mann, Jr.	6,000	CW4 Mary E. Willamee	5,200
CW4 Michael C. Pascalar	7,300	CW4 Wayne K. Walker	6,000	CW5 Delors Ross	5,100
CW5 Jeffrey M. Swickard	7,300	CW4 Alden Dustin Woodbury	6,000	CW4 Mark D. Terry	5,100
CW5 Donn D. Olson	7,059	CW5 Walter E. Riley	5,900	CW3(P) Michael Bukowski	5,000
CW5 William J. Clark	7,000	CW5 Myron F. Babcock	5,800	CW5 Richard L. Williams	5,000
CW5 William H. Ramsey	7,000	CW5 John R. Dougherty	5,700	CW4 Luis Zamudio	5,000
CW5 Harry R. Ward	6,950	CW5 James E. Manley	5,700		

### Transition cont'd. from page 8

complement the mental agility inherited from Force XXI. Air mechanization is envisioned to be the breakthrough that:

- allows a force to exploit terrain without being constrained by it;
- enables dominant maneuver at speeds and distances well beyond today's;
- allows a force to exploit anticipatory planning and situational awareness, and achieve positions of decisive advantage at any spectrum of conflict; and
- allows a force to conduct decisive joint, combined or coalition operations.

Our Battle Lab led by Col. Gary Coleman and combat developers teamed with Col. Jim Herberg's TSM-Comanche, TSM-Longbow, and our training, doctrine and simulations folks led by Col. Bill Powell, will continue to work and plan for this fight.

In closing, there are a number of key players that will influence the path to the Army After Next [Figure 1]. I am firmly convinced that all

of them are as committed as we here at Fort Rucker are to seeing that the transitions are as smooth as they can be. The 21st century will be an exciting, challenging and rewarding time to be in our Army and in Army aviation.

But even with all the change and technological advances, three basic truths will still stand: The highest quality soldiers, trained to world-class standards to fight and maintain the most advanced equipment in the world will remain the decisive difference in the defense of this great nation. Today's lieutenants in the Officer Basic Course and captains in the Officer Advance Course will be the battalion and brigade commanders who lead these soldiers. Army aviation is committed to ensuring that their leader development and equipment are the finest in the world. Above the Best!

\* \*

*MG Petrosky is Aviation Branch Chief and CG, U.S. Army Aviation Center (USAAVNC) and Ft. Rucker, AL, and Commandant, U.S. Army Aviation Logistics School (USAALS), Ft. Eustis, VA.*

## U.S. ARMY AIRCRAFT SINCE 1947

Since 1947 - An Illustrated Reference

Stephen Harding



*U.S. Army Aircraft Since 1947* is the only comprehensive, up-to-date guide to the 124 types of helicopters, fixed-wing aircraft and experimental flying machines used by the U.S. Army since 1947. After a concise yet thorough introductory history of U.S. Army Aviation, the author discusses each aircraft type used by the Army's air arm, which is the largest, most technologically advanced and most combat experienced force of its kind in the world today. Within each chapter the author includes information on aircraft serials, markings, weapon systems, operational history and other technical data. Illustrated with more than 220 color and black and white photographs, *U.S. Army Aircraft Since 1947* is the definitive reference source on its subject and a must-have volume for all military aviation historians and enthusiasts. [Schiffer Publishing Ltd. Size: 8 1/2" x 11", 264 pages, hard cover; ISBN: 9-7643-0190-X]

## YEAR OF THE HORSE: VIETNAM

1st Cavalry in the Highlands 1965-1967

COL Kenneth D. Mertel (USA, Ret.)

*Year of the Horse: Vietnam* is the day-to-day story of the Jumping Mustangs - 1st Battalion, Airborne, 8th Cavalry, of the 1st Air Cavalry Division. After describing the activation of this then revolutionary airmobile division at Fort Benning, GA on 1 July 1965, COL Mertel gives a vivid picture of the building of his own Jumping Mustang Battalion, the rigorous training of officers and men, and, finally, the long voyage across the Pacific to Vietnam. Now the test. The answer came quickly and dramatically in a rapid succession of search and destroy operations. COL Mertel pays tribute to the many acts of heroism of his men, who lived, worked and fought together in some of the world's most inhospitable conditions. He also writes movingly of those who never came back. [Schiffer Publishing Ltd. Size: 6"x9", 384 pages, hard cover; 59 color photographs, 9 maps; ISBN: 0-7643-0138-1]



## A CAVALRYMAN'S STORY

Memoirs of a Twentieth Century Army General

Hamilton H. Howze

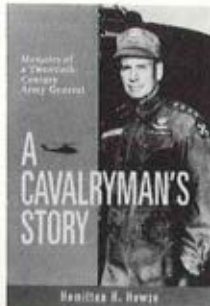

*A Cavalryman's Story* is the memoir of a professional soldier, born into the lineage of West Point and recognized today as the father of U.S. Army Airmobile tactics and doctrine. With understated charm and humor, GEN Howze writes of his polo-playing years in a 1930s Army that still relied on horses, and then of the sudden, almost remarkable transition to armored divisions, when the U.S. entered WWII. It was in the mid-1950s that GEN Howze emerged as one of a handful of perceptive Army officers who recognized the potential of a sky cavalry. As the first director of Army Aviation GEN Howze promoted the concept to industry, the government, and the public. His vision came to fruition in the 1960s when he presided over the U.S. Army Tactical Mobility Requirements Board, known as the Howze Board, which proved the viability of sky cavalry in combat. *A Cavalryman's Story* provides an authoritative look at the forging of the modern Army and a wry perspective on the perennial absurdities of military life, whether in peace or war. [Smithsonian Institution Press. Size: 6"x9", 316 pages, hard cover; ISBN: 1-56098-664-6].

# BOOK STORE

## Breaking the

A New Design for  
Landpower in  
the 21st Century

Douglas A. Macgregor  
Reviewed by Robert Taylor

Publications and Sales Office for Army Aviation  
Publications Division

## BREAKING THE PHALANX

Douglas A. Macgregor

This work proposes the reorganization of America's ground forces on the strategic, operational and tactical levels. Central to the proposal is the simple thesis that the U.S. Army must take control of its future by exploiting the emerging revolution in military affairs. The analysis argues that a new Army warfighting organization will not only be more deployable and effective in Joint operations; reorganized information age ground forces will be significantly less expensive to operate, maintain, and modernize than the Army's current Cold War division-based organizations. And while ground forces must be equipped with the newest Institute weapons, new technology will not fulfill its promise of shaping the battlefield to American advantage if new devices are merely grafted on to old organizations that are not specifically designed to exploit them. [Praeger

Publishers. Size: 6"x9 1/8", paperback, 283 pages, ISBN: 0-275-95794-2]

## WE WERE SOLDIERS ONCE... AND YOUNG

Harold G. Moore and Joseph L. Galloway

*We Were Soldiers Once ... And Young* brings the war back home with unforgettable stories of those who lost family members to combat. This devastating account rises above the specific ordeal it chronicles to present a picture of men facing the ultimate challenge, dealing with it in ways they would have found unimaginable only a few hours earlier. It reveals to us, as rarely before, man's most heroic and horrendous endeavor. [Harper Collins Publishers, Size 5 1/2"x8". 483 pages, paperback. ISBN: 0-06-097576-8

THE NEW YORK TIMES BESTSELLER  
LA DRANG: THE BATTLE THAT  
CHANGED THE WAR IN VIETNAM

WE WERE  
SOLDIERS ONCE...  
AND YOUNG



LT. GEN. HAROLD G. MOORE (Ret.)  
and JOSEPH L. GALLOWAY

### ORDER YOUR BOOKS TODAY!

Name \_\_\_\_\_

Address \_\_\_\_\_

City, State & Zip \_\_\_\_\_

Tele: \_\_\_\_\_ FAX: \_\_\_\_\_

I prefer to pay as follows:  Check  MasterCard  VISA

Credit Card # \_\_\_\_\_ Exp. \_\_\_\_\_ Signature: \_\_\_\_\_

U.S. ARMY AIRCRAFT - Harding	# _____	\$50.00*	\$ _____
YEAR OF THE HORSE: VIETNAM - Mertel	# _____	\$40.00*	\$ _____
A CAVALRYMAN'S STORY - Howze	# _____	\$29.95*	\$ _____
BREAKING THE PHALANX - Macgregor	# _____	\$29.95*	\$ _____
WE WERE SOLDIERS ONCE...AND YOUNG - Moore and Galloway	# _____	\$20.00*	\$ _____
		<b>TOTAL</b>	<b>\$ _____</b>

\*(Prices Already Include Shipping & Handling Fee)

Place your order now to receive your free copy of  
"Army Aviation Cub to Comanche"

Please return this form, with payment to:

Army Aviation Publications, Inc., 49 Richmondville Ave., Westport, CT 06880-2000

Tele: (203) 226-8184 - FAX: (203) 222-9863

Allow 6-8 Weeks For Shipment • \*Add 6% Sales Tax If Shipping To Connecticut

# ARRIVALS DEPARTURES



## COLONELS

**Prewitt, David S.**, 59 Ingalls Road, Fort Monroe, VA 23651.EM: ArmyGolfer@aol.com

**Walker, Robin C.**, HQ, USAREUR, CMR 420, Box 2404, APO AE 09063.

## LT. COLONELS

**Meyer, Dan C.**, USDAO San Salvador, Unit 3108, APO AA 34023.

**Petrick, Thomas G.**, 5505 Seminary Road, Apt. 1815 North, Falls Church, VA 22041.EM: petrick@aol.com

## MAJORS

**Hartnett, Brett A.**, 2617 S Bridger Drive, Billings, MT 59102.

**Murray, Barry G.**, 804 Overbrook Drive, Fort Walton Beach, FL 32547.

**Wiggins, Perry L.**, 463 Holly Drive, Robins AFB, GA 31098.

**Woods, Kevin M.**, Iron Mike Chap Mil Afters., 414 Summerlea Drive, Fayetteville, NC 28311.

## CAPTAINS

**Batts, Stacy M.**, B Co, 2/52 Avn Regt, Unit 15212, Box D-14, APO AP 96271.

**Horne, Jason R.**, 5852 Wye Oak Commons Ct., Burke, VA 22015.

**Libby, Jeffrey A.**, 3518-B Kanell Loop, Wahiawa, HI 96786.

**Ridley, Jeffrey**, P.O. Box 620214, Fort Rucker, AL 36362.

## 1ST LIEUTENANTS

**Pierce, Brian C.**, 111 Cumberland Green Dr., Cary, NC 27513.

## 2ND LIEUTENANTS

**Asborno, Anthony J.**, 71 A.M. Windham Dr, No. 702, Daleville, AL 36322.

**Boyer, Kory E.**, 507 Briarwood Drive, Apt. 13A, Enterprise, AL 36330.

**Hill, Matthew B.**, 402 Regency Drive, Suite 201, Fayetteville, NC 28314.

**Maki, Heather L.**, 104 Weeks Drive, No. 14, Enterprise, AL 36330.

**Thompson, Mikkel L.**, 201 Dixie Dr., No. 37, Enterprise, AL 36330.

## CW5s/MW4s

**White, Dennis E.**, HSC 3rd MI Bn (AE), Unit 15220, Box 1124, APO AP 96271.EM: whited@humphreys3-501mi.korea.army.mil

## CW4s

**Ferrell, Ronald J.**, 1021 Grande View Blvd., No. 227, Huntsville, AL 35824.EM: ferrellr@comanche.redstone.army.mil

**Trigger, Michael E.**, 15860 Montview Dr, Dunfries, VA 22026.

## CW2s

**Conlin, Curt R.**, CMR 402, Box 1718, APO AE 09180.EM: conlin\_cr@hotmail.com

**Reich, Clark E.**, 2011A Shannahan Drive, Fort Campbell, KY 42223.EM: clark.reich@nsionline.com

## WO1s

**Hathaway, Steven T.**, 1217 Hand Drive, Clarksville, TN 37042.

**Miller, Clinton A.**, 2137 Martha's Chapel Road, Apex, NC 27502.EM: clintonmiller@hotmail.com

**Robinson, Allen C.**, B Co. 1-145th Avn Regt, CMR 3, Box 7807, Fort Rucker, AL 36362.

## DACs

**Lall, Bhisham J. Mr.**, P.O. Box 22354, Huntsville, AL 35814.

## CIVILIAN

**Bryant, Lawrence E.**, 1511 Jasmine Court, Jackson, NJ 08527.

## RETIRED/OTHER

**Curtis, Phillip L.** COL, 4503 Buffalo Trace, Annandale, VA 22003.

**Lester, Rodney D.** LTC, 15223 S.E. 178th Place, Renton, WA 98058.



## PRESIDENT'S MESSAGE

By Maj Gen. Dave Robinson, President AAAA

A couple of months ago in this column, I reviewed the various fronts on which our association is moving. Initiatives ranged from our new MasterCard credit card program and our legislative action efforts with The Military Coalition, to the various symposia that we sponsor.

The last session of the most recent event, the Aviation Electronic Combat Symposium, really proved how valuable these symposia are.

Held a few weeks ago at the Opryland Hotel in Nashville, Tennessee, the AEC Symposium brought together Electronic Warfare Officers, maintainers, engineers, and manufacturers in an informal and collegial atmosphere to discuss the critical technologies of Avionics, and Aircraft Survivability Equipment.

The day and a half event featured outstanding professional briefings from the government as well as industry, included customer and contractor exhibits, and sparked many offline discussions.

The various receptions, lunches and dinners fostered this atmosphere of exchange and helped make fresh friendships and renew old ones. The award ceremonies and the preceding speech by BG Dick Cody, then commander of the 160th, Special Operations Aviation Regiment (Airborne), helped keep us focused on the real world of the operators. In addition, your association awarded excellence through the presentation of the Avionics and ASE awards to two outstanding individuals, CW3 Jack B. Pike and Mr. Robert B. Carneal, Jr.

However, it was the last session of this event, a question and answer session Thursday morning, November 6, 1997 that really demonstrated how AAAA can contribute to the warfight.

Started by the ever shy and retiring CW4 Brad (Boog) Powell, of the 160th SOAR(A) Night Stalkers (and former ASE Award winner himself), through questions from FORSCOM standardization officers, Reserve unit officers from Texas, and enlisted maintainers from the 160th, significant issues were raised. Issues like how to meet the requirement to test Army IFF systems before every flight were aired. The mismatch of equipment at the unit level, improperly installed antennas, and a misunderstanding of the purpose of test procedures were discussed. In addition, some maintainers felt that current test procedures did not give them the confidence to guarantee their pilots that the ASE was 100%.

In some cases discussion showed that a simple lack of communication or understanding of intent had occurred. In others, systemic problems were revealed, like an inability to access the AEC web site because of a lack of personal computers at the EWO level.

The bottom line was that AAAA provided a superb opportunity for a frank and open airing of some critical life and death operator level issues that may not have occurred at all, or only in some piecemeal fashion sometime in the future.

This is a big part of what AAAA is all about. The AAAA provides a professional and collegial environment for the exchange of ideas that can affect the way we think and fight.

Hats off to everyone who contributed so much to the success of the 15th annual AAAA AEC Symposium. I would like to especially recognize the new AEC PM Larry Johnston, the professional program chairman, whose entire office was in the process of moving from St. Louis to Huntsville during the organization of the event, and Ron Kurowsky, Chief Avionics Branch, Software Engineering, CECOM. I would also like to thank MG Jim Snider, PEO Aviation, the keynote speaker, and Mr. James Barbarello, Director, Command and Control Systems Integration Directorate, CECOM, the luncheon speaker, for taking time from their busy schedules to be with us. By the way, videotapes of the entire event are available from the AAAA National Office.

Next week, I will sit down in Washington with the AAAA Strategic Planning Committee under the leadership of its Chairman Brig. Gen. Harry Bendorf, to set the course for the next year. I'll brief you on the agreed upon goals and objectives soon.

On behalf of the AAAA National Executive Board, please enjoy a safe and joyous holiday season.

**1997 ASE Award Citation**  
**CW3 Jack B. Pike,**  
**8-229 Avn Regt (ATK)**  
**Ft. Knox, KY**

CW3 Jack Pike's contributions have made a dramatic and lasting impact on Army Aviation and Aircraft Survivability Equipment and Electronic Warfare across the entire Armed Forces.

During the awards period of August 1, 1996 to July 31, 1997, he was solely responsible for five major, high impact, ASE/EW actions.

These included: the design, acquisition, and implementation of a state of the art Electronic Warfare Center; research, coordination and implementation of Joint ASE/EW operations training with the Air Force on area Electronic Warfare ranges; realistic Battalion and Company collective ASE/EW training, a USAR wide ASE/EW training program; and establishment of an Ambassadorship program whereby he personally briefed and advised units and individuals from the Active Component, National Guard, Air Force, Armor Center, Canadian Forces, and the Royal Netherlands Air Force.



CW3 Jack B. Pike (center) 1997 ASE Award Winner accepts his award from AAAA President, MG Dave Robinson, Ret., center left, as PM AEC, Larry Johnston, left, then COL(P) Richard Cody, Commander 160th SOAR(A) and Mr. William P. Leach of the Award's Sponsor, Lockheed Martin, look on.

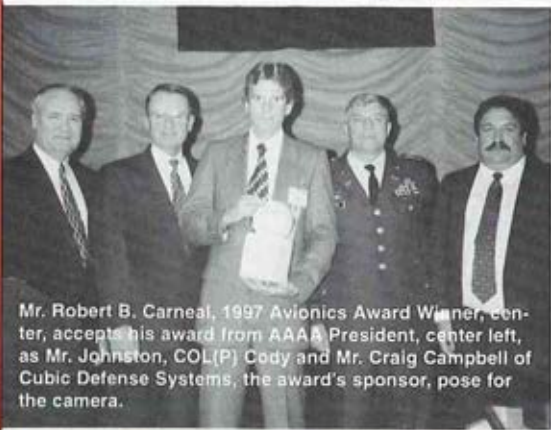

Mr. Robert B. Carneal, 1997 Avionics Award Winner, center, accepts his award from AAAA President, center left, as Mr. Johnston, COL(P) Cody and Mr. Craig Campbell of Cubic Defense Systems, the award's sponsor, pose for the camera.

CW3 Pike is a combat multiplier who is peerless in the Army Aviation community. Indeed, his mastery and use of advanced technology placed 8-229th AVN REGT (ATK) in the forefront of all Army Aviation assets, Active or Reserve Component, while posturing the Battalion for success in Force XXI.

**1997 Avionics Award Citation**  
**Mr. Robert B. Carneal,**  
**D Company, 12th Avn Bn**  
**Ft. Belvoir, VA**

During the past year Mr. Carneal, a civilian avionics mechanic with D Company, 12th Aviation Battalion, Fort Belvoir, VA, distinguished himself in many ways and was selected above his peers to lead the avionics section when his supervisor left with an early retirement.

Because a hiring freeze was in place, the battalion could not hire a replacement for the supervisor position. Without any increase in pay, he volunteered to do the work of an avionics lead and with no previous lead experience managed the avionics section exceptionally well.

He kept up with work orders and aircraft modifications, despite having only a 60% personnel fill for the year. In addition, he continued to excel at his primary job as an avionics mechanic and maintained 100% accountability of over \$450,000 of electrical and avionics equipment. He also set out to modernize the avionics shop and expand the technical capabilities of the shop given a very limited budget.

His own technical skills were also clearly outstanding. With so few personnel in the shop, he was often troubleshooting the most difficult problems personally as well as training other mechanics. All of this is all in addition to the additional lead duties.

His selfless dedication to ensuring the battalion had the best avionics maintained avionics equipment in the Army was unparalleled. Mr. Carneal's exemplary performance increased the unit's overall operational readiness during the awards period and made him the clear choice to receive the 1997 AAAA Avionics Award.

## MARKETPLACE

**SEIZED CARS** from \$175 - Porsches, Cadillacs, Chevys, BMW's, Corvettes. Also Jeeps, 4WD's. Your Area. Toll Free 1-800-218-9000 Ext. A-14106 for current listings.

## AAAA Credit Cards Coming Soon!

AAAA, in conjunction with MBNA America Bank®, has developed a unique No-Annual-Fee credit card program designed especially for AAAA members. For every new card used, MBNA America will contribute money to help support the AAAA Scholarship Foundation, Inc. Then, every time you use the card to make a purchase, the Foundation will also receive a contribution from the bank at no additional cost to you. The AAAA credit card will feature our unique logo and specially selected images of your favorite aircraft, identifying you as a supporter and sparking the interest of everyone who sees them!

*Look for the first  
promotional mailing  
this month!*

Contact AAAA for details

Tel: (203) 226-8184

Fax: (203) 222-9863

E-Mail: [aaaa@quad-a.org](mailto:aaaa@quad-a.org)



MasterCard is a federally registered service mark of MasterCard International, Inc.; to be used pursuant to license. MBNA America Bank is a federally registered service mark of MBNA America Bank, N.S.

**AIR ASSAULT  
CHAPTER  
FORT CAMPBELL, KY**

CW2 Charles M. Branson  
CW2 Michael D. Kelley

**ALOHA CHAPTER  
HONOLULU, HI**

MSG Patrick J. Laidlaw

**ARIZONA CHAPTER  
MESA, AZ**

Mr. Peter Lautzenheiser

**ARMADILLO CHAPTER  
CONROE, TX**

CW3 James K. Denton

**AVIATION CENTER  
CHAPTER  
FORT RUCKER, AL**

WO1 Fred Baca, Jr.  
WO1 Michael S. Benthin  
2LT Mekola Bidanec  
2LT Tommy D. Bowling, Jr.  
WO1 Michael J. Bush  
2LT Darren W. Buss  
WO1 Jason S. Callegari  
WO1 Michael D. Cavaco  
WO1 Donald V. Clark  
1LT(P) Robert E. Clemmer  
2LT Justin Z. Covey

2LT Mark C. DeLorenzo  
2LT Linn K. Desaulniers  
2LT Jeffrey C. DiCostanzo  
2LT Daniel F. Dittenber  
2LT Todd D. Farrell  
WO1 Anthony J. Ferrio  
WO1 Rondall G. Frazier  
MAJ Dennis Genualdi  
WO1 Pedro Gutierrez Jr.  
2LT Mark C. Haines  
WO1 Jason W. Hiller  
2LT Greg Iannucci  
2LT Paul E. Johnson  
WO1 David J. Keel  
2LT John H. Kendall  
WO1 Jeffrey T. Kimm  
WO1 Manual M. Kinsey  
WO1 Maurice A. Lammie  
2LT Ryan D. McAfee  
2LT Joseph R. McCoy  
WO1 Steven J. McCurdy  
WO1 Adam H. Mouser  
WO1 James Aaron Nance  
1LT Scott M. Nowicki  
WO1 David L. Parks, II  
2LT Kevin J. Rapp  
WO1 William J. Rector  
CPT Stephen L. Rhoades  
2LT Anthony C. Rovano  
2LT Frederick W. Scheuren  
WO1 Raymond M. Smiley  
2LT Henry J. St. Germain Jr.  
2LT Chad A. Stover  
2LT Jeffrey J. Sullens  
2LT Brian T. Sullivan



**CPT Yolonda R. Summons**

WO1 Carlyle S. Swolford III  
2LT Pierce N. Thomas  
2LT Ken S. Thompson  
2LT Steven A. Turner  
WO1 Scott E. Uszynski  
2LT Jefferey W. Valentine  
2LT Juan P. Villasenor  
WO1 Gregory L. Walker  
Dr. James W. Williams

**CEDAR RAPIDS  
CHAPTER  
CEDAR RAPIDS, IOWA**  
SFC John P. Glodowski

**COLONIAL  
VIRGINIA CHAPTER  
FORT EUSTIS, VA**  
SSG James A. Hodge, Jr.  
MSG Lubie D. Perritt, Ret.

**CORPUS CHRISTI  
CHAP. CORPUS  
CHRISTI, TX**

Mr. Pete Rivera

**EDWIN A LINK  
MEMORIAL CHAPTER  
BINGHAMTON NY  
AREA**

CW4 Richard W. Edgington  
**GREATER ATLANTA  
CHAPTER  
ATLANTA, GA**  
LTC Samuel E. Seetin, Jr, Ret

**IRON MIKE CHAPTER  
FORT BRAGG, NC**  
CW2 Owen N. Daugherty  
CPT Kenneth G. Moreno  
CW3 William J. Roberts

**MISSION READY  
CHAPTER  
GIEBELSTADT,  
GERMANY**  
CW2 Prince A. Denson

WO1 Mark G. Deturler  
SPC Lisa M. Lopez  
CW2 Douglas S. Miller  
CW2 William J. Roberts  
CPT Craig A. Wilhelm

**MONMOUTH CHAPTER  
FORT MONMOUTH, NJ**  
SPC Robert M. Burd

**MORNING CALM  
CHAPTER  
SEOUL, KOREA**  
MAJ Suzanne C. Hickey

**NARRAGANSETT BAY  
CHAPTER  
N. KINGSTOWN, RI**  
SPC Eric A. Paulhus

**NORTH COUNTRY  
CHAPTER  
FORT DRUM, NY**  
MAJ Joseph A. Bassani, Jr.  
Mr. Gary B. Lawrence  
BG Zannie O. Smith  
SPC Brian J. Walsh  
CPT Scott M. Williams

**NORTH TEXAS  
CHAPTER  
DALLAS/FORT WORTH**  
Mr. Woody Ano  
Mr. David A. Aiyers  
Mr. Dave Baker  
Mr. Jim Brown  
Mr. Greg Byrnes  
Mr. Chris Christensen  
Mr. Steve Church  
Mr. Bruce A. Conner  
Mr. Dennis A. Crook  
Mr. Richard L. Dial  
Mr. Chris Dibesualdo  
Mr. Dave Embree  
Mr. Don Ferguson  
Mr. Joey Ferguson

Mr. Scott Gazalski  
Mr. Kevin J. Gordon  
Mr. Joe E. Gray  
COL Frank Y. Hartline, Ret.  
Mr. Buster Hooper  
Mr. Scott Howell  
Mr. Wayne Lehr  
Mr. T. G. Marshall  
Mr. Bryan Miller  
Mr. Tom Myers  
Mr. P. R. Patel  
Mr. Robert A. Peterson  
Mr. Robert E. Portor  
Mr. Billy J. Scott  
Mr. James T. Shipley  
Mr. James W. Smith  
Mr. Richard Street  
Mr. Masanori Sugaya  
Mr. Bill Summerlin  
Mr. William A. Thomas  
Mr. Otis R. Turner  
Mr. Steve D. White  
Mr. Brandon B. Williams

**SAVANNAH CHAPTER  
FT STEWART/HUNTER  
AAF, GA**  
CPT James F. Farrell  
CW4 Eric R. Lechner  
MAJ Mariles D. Renojo

**SINAI CHAPTER  
SINAI, EGYPT**  
LTC Ronnie L. Foxx  
CW3 Gary S. Scott

**TALON CHAPTER  
ILLESHEIM, GERMANY**  
SGT Christina Backlow

**TENNESSEE VALLEY  
CHAPTER  
HUNTSVILLE, AL**  
Ms. Patricia K. Hildebrand  
Mr. Steven L. Messervy  
LTC John D. Miller, Sr., Ret.

**VIRGINIA MILITARY  
INSTITUTE  
LEXINGTON, VA**  
CDT Frank L. Jackson III  
CDT Andrew J. Modisett  
CDT John C. Parson  
CDT Emily P. Van Arman

**MEMBERS  
WITHOUT  
CHAPTER  
AFFILIATION**  
Mr. Craig C. Campbell  
CPT Louis E. Carmona  
Mr. Martin R. Karig  
LTC Daniel A. Matulewicz  
LtCol Theo H.W. Ten Haaf

## Washington D.C., & Potomac Chapter Merge

The members of the Washington, D.C. Chapter, based at Fort Belvoir, Va., have voted to merge with the Arlington, Va.- based Potomac Chapter of AAAA.

By way of background, the current Washington, D.C. chapter moved from the immediate D.C. area to Fort Belvoir, Va., in 1987. The current Potomac Chapter, previously named the Chesapeake Bay Chapter, was headquartered at Aberdeen Proving Ground, Md., with the National Guard Bureau until 1994, when it moved to the National Guard Readiness Center in Arlington, Va.

The members present at a joint chapter meeting held in July felt it would be in the best interest for both chapters to merge and to establish a vice president for Fort Belvoir affairs to address member concerns at Fort Belvoir. A ballot was sent to the members of the Fort Belvoir-based chapter who voted, 235 in favor, seven against to combine with the Arlington-based chapter.

The president of the newly enlarged Potomac Chapter is Col. Joseph L. Ferreira. The new vice president for Fort Belvoir affairs is Col. Billy Wood. Other officers include: Col. Robert A. Wagg, Jr., Ret., treasurer, CWO 4 Robert L. Fleming, vice president, membership; CWO 5 Rick F. Andrews, vice president, membership renewals; SFC Pamela L. Shugart, vice president programs; and Col. Ralph J. W. K. Hiatt, Ret., vice president, industry affairs.



*Do you know  
a potential  
Soldier of the Year?*

**NATIONAL AWARD  
NOMINATIONS  
DUE AT THE AAAA NATIONAL  
OFFICE ON OR BEFORE  
JAN. 15, 1998**

## New AAAA Chapter Officers

### Aviation Center:

Col. R. Lee Gore (President); Lt. Col. Bruce D. Redline (Treas.); Maj. James R. Bullinger (VP Publicity); Col. Neal Sealock (1st Bde Rep)

### Lindbergh:

Ms. Diane F. Ottolini (VP Civilian Affairs); Col. Gerald C. Green, Ret. (VP Military Affairs); Ms. Georgia M. Crenshaw (VP Programs); Lt. Col. John E. Sparks, Ret. (VP Publicity)

### Sinai:

Capt. Peter Dykman (Treas); Capt. Heidi A. Jentoft (VP Membership Enrollment)

## AAAA Aviation Soldiers of the Month

A Chapter Program to Recognize Outstanding Aviation Soldiers on a Monthly Basis

**Sgt. Christina Backlow**  
September 1997  
(Talon Chapter)

**Spec. Brian J. Walsh**  
October 1997  
(North Country Chapter)

**Spec. Eric A. Paulhus**  
November 1997  
(Narragansett Bay Chapter)

**New AAAA  
Sustaining Members**  
Mitsui Bussan Aerospace  
Corporation

## Aces

The following members have been recognized as Aces for their signing up five new members each.

**Maj. D. Lee Hackle**  
CWO2 Timothy S.  
Ashcom  
**Lt. Col. Michael F.**  
McClellan, Ret.

## SFC Joseph "Joe" W. Strousky, Ret.

SFC Joseph W. Strousky, retired, 68, a pioneer in Army air traffic control, died Oct. 25, 1997 in Panama City, Fla. When Army aviation moved to Fort Rucker, SFC Strousky managed the first base operations section at then Ozark Army Airfield. Joe was one of the initial ground control approach controllers in the Army's first GCA facility. After retiring from active duty, Joe worked as a civilian controller at the Cairns Army Radar Approach Control facility from 1968 to 1988. He is survived by his three daughters, Helen, Kathy and Mary of Daleville, Ala.



"I knew it was going to be a big event, but it was bigger than I expected!" exclaimed Col. Lee Gore, Aviation Center chapter president. Gore presided over his first and the Chapter's 6th annual AAAA Chili 5K race and chili cook-off at Fort Rucker's center parade field on Oct. 25th. A record 587 people, including 34 teams, ran in the 5 kilometer road race. Thirty-one chili teams competed in the cook-off competition. An estimated 1,000 people tasted sample cups of chili.

Maj. Gen. Daniel J. Petrosky and Brig. Gen. Charles M. Burke, Fort Rucker's commanding and deputy commanding generals, served as this year's distinguished award presenters.

Above, Maj. Gen. Petrosky (center right) presents Capt. Brian P. Zarchin his plaque, bragging rights, and five T-shirts for winning this year's CSK T-shirt logo design contest. Below, runners of all ages line up for the start of the 5K race.

Aviation Center AAAA chapter plans to hold next year's 7th annual Chili 5K on Sat., Oct. 31.



## AAAA CALENDAR

A Listing of Upcoming  
National and Chapter Events

### January 1998

**Jan 22.** AAAA Aviation Center Chapter Banquet, Fort Rucker, AL. Awards Presentations: AAAA Aviation Trainer of the Year, Air/Sea Rescue Award, Aviation Fixed Wing Unit Award, Aviation Medicine Award, ROTC Award, and Air Traffic Control Awards Presentations. Contact: CPT Darryl Doberstein, 334-255-2313.

**Jan 28-30.** AAAA Joseph P. Cribbins Product Support Symposium, sponsored by the AAAA Tennessee Valley Chapter, and the AAAA Logistics Support Unit Award and AAAA Industry Awards Presentations, Marriott Space & Rocket Center, Huntsville, AL.

**Jan 30.** AAAA Scholarship Board of Governors Executive Committee Meeting, National Guard Readiness Center, Arlington, VA.

**Jan 31.** AAAA National Awards Selection Committee Meeting, National Guard Readiness Center, Arlington, VA.

### February 1998

**Feb. 2-6.** Aviation Leader's Training Conference (ALTC), U.S. Army Aviation Center, Ft. Rucker, AL.

**Feb 6.** Aviation Center Chapter Spring Classic Golf Tournament, Ft. Rucker. Contact: CW2 Jim Kennedy, 334-255-3411

**Feb 20.** Aviation Center Chapter General Membership Meeting and Member Appreciation Night, Ft. Rucker O'Club. Contact LTC Tom Young, 334-255-5712.

**Feb 21.** AAAA Morning Calm Chapter Winter Formal, Grand Hyatt, Itaewon, Seoul, South Korea. Guest Speaker: LTG Randolph W. House, Commanding General, Eighth United States Army. Contact: CPT Jennifer J. Manzo, HHC, 17th Avn. Bde., Unit 15270, APO AP 96205-0043. E-mail: eaavap@emh2.korea.army.mil.

## ●CFC●CFC●CFC●CFC●

The AAAA Scholarship Foundation, Inc. (AAAASFI) is now part of the Combined Federal Campaign (CFC), a workplace charitable fund drive conducted by the U.S. Government for all federal employees. It is the single largest workplace fund drive in the country, raising approximately \$195M in pledges annually.



Please consider making a CFC-sponsored contribution to the AAAA Scholarship Foundation this year.



## AAAA Scholarship Foundation

Scholarships "dedicated" to Enlisted, Warrant Officer, Company Grade Officer, and Department of the Army Civilian Members.

Funds also available for spouses, siblings & children of AAAA Members

Contact the  
AAAA Scholarship Foundation, Inc.  
49 Richmondville Avenue  
Westport, CT 06880-2000  
Tel: (203) 226-8184  
FAX: (203) 222-9863

E-MAIL: [aaaa@quad-a.org](mailto:aaaa@quad-a.org) for details

**Application Deadline:  
May 1, 1998**



**HE WORKS IN A  
TOUGH NEIGHBORHOOD.  
COLLINS AVIONICS  
MAKE IT SAFER.**

NAVIGATION • COMMUNICATIONS • DATA LINKS • FLIGHT MANAGEMENT • SYSTEMS INTEGRATION

Collins innovations come to life in an unmatched variety of navigation and communications products that keep him connected and situationally aware. They make his mission more effective and easier to integrate within any theater of operations. Then, when the job is done, they guide him home. Call and find out how we can help make the neighborhood safer. Our Customer Proposal Response Team will find answers for land, sea or air. Call (800) 321-2223 or (319) 295-5100. [www.cacd.rockwell.com](http://www.cacd.rockwell.com)

 **Rockwell**

*Avionics & Communications*

**Collins**