

Special Focus:
International
Army
Aviation

ARMY AVIATION MODERNIZATION PLAN

ARMY AVIATION

OFFICIAL PUBLICATION OF THE ARMY AVIATION ASSOCIATION OF AMERICA • JUNE 30, 1995



The Boeing Chinook. A force in peace and war.

BOEING

RAH-66 Comanche

High Value.

The Comanche helicopter allows significant reductions in personnel and support equipment while achieving higher levels of operational effectiveness.

No other helicopter alternative provides the field commander with this degree of supportability, reliability, and mission availability:

- \$20 billion savings in operating and support costs – 83% reduction in support equipment, 32% less manpower, 34% fewer spares
- Cuts maintenance time in half – increases combat readiness
- Cuts maintenance levels by one-third – reduces personnel training requirements and the need for expensive test equipment
- Comanche reconnaissance 6 times more effective than next best alternative – reduces reconnaissance helicopter losses 97%
- Only tactical asset that links armor, aviation, artillery, and infantry – battle commander's probability of victory is increased by a factor of ten

Corroborating studies available upon written request.

**RAH-66 Comanche. Preparing for first flight.
And not a moment too soon.**



BOEING SIKORSKY
RAH-66 COMANCHE TEAM

PUBLISHER
Lynn Coakley

ASSOCIATE PUBLISHER
Terrence M. Coakley

EDITOR
William R. Harris, Jr.

ASSOCIATE EDITOR
Stephen Moore

CIRCULATION MANAGER
Jill Thomas

CIRCULATION ASSISTANTS
Mary Ann Stirling, Debbie Coley, Deb
Simons, Mary Ellen Kother

ADVERTISING

Display and classified advertising rates are listed in SRDS Business Publications, Classification 90. Information and rates are available from the Production Department at Tel: (203) 226-8184 or FAX: (203) 222-9863, or our Advertising Representative: Peter M. Stern, Stern Marketing Company, Tel: (203) 532-0335 or FAX: (203) 532-0131.

ARMY AVIATION is the official journal of the Army Aviation Association of America (AAAA). The views expressed in this publication are those of the individual authors, not the Department of Defense or its elements. The content does not necessarily reflect the official U.S. Army position nor the position of the Army Aviation Association of America (AAAA) or the staff of Army Aviation Publications, Inc., (AAPI). Title reg® in U.S. Patent Office. Registration Number 1,533,053.

SUBSCRIPTION DATA

ARMY AVIATION (ISSN 0004-248X) is published monthly, except April and September by AAPI, 49 Richmondville Avenue, Westport, CT 06880-2000. Tel: (203) 226-8184. Subscription rates for non-AAAA members: \$25, one year; \$48, two years; add \$10 per year for foreign addresses other than military APOs. Single copy price: \$3.00.

POSTAL

Second class postage paid at Westport, CT and other offices.

POSTMASTER

Send address changes to AAPI, 49 Richmondville Avenue, Westport, CT 06880-2000.

FORTHCOMING ISSUES

July 1995 — Special Operations Aviation and Night Vision updates.

August-September 1995 — Annual Army Aviation "BLUE BOOK" Directory.

Briefings

Several major assignments in senior personnel have been announced: **LTG Ronald H. Griffith** has been named the Army Vice Chief of Staff; **MG John S. Cowings**, Commanding General, U.S. Army Aviation and Troop Command (ATCOM), St. Louis, MO, relinquished command 12 June to **MG John J. Cusick**. MG Cowings is now attending the Industrial College. **BG Peter C. Franklin** will become Commanding General, U.S. Simulation, Training, and Instrumentation Command (STRICOM), Orlando, FL; **BG Thomas W. Garrett** will become the Assistant Division Commander, 101st Airborne Division (Air Assault), Ft. Campbell, KY; **BG Dan J. Petrosky** will become the Deputy Chief of Staff for Operations, USAREUR and 7th Army; **BG Burt S. Tackaberry** has been named Deputy Commanding General, Ft. Rucker, AL; and **COL(P) Warren C. Edwards** will become the Assistant Division Commander, 2nd Infantry Division, APO AP. In addition, **Mr. Larry D. Holcomb** has been named Acting Program Executive Officer, Aviation upon **MG Dewitt T. Irby's** retirement in late July, and **Mr. Paul Bogosian**, former Executive Director, ATCOM Acquisition Center, has been named Deputy CEO.

The Royal Netherlands Air Force has selected the **McDonnell Douglas Helicopter Systems AH-64D Longbow Apache** to perform the heavy attack role in its Airmobile Brigade. The aircraft, which will not be equipped with the Longbow Fire Control Radar system, will be delivered beginning in the first quarter of 1998.

The **Maintenance Data Management Bulletin Board System (BBS)** is now available. A user has access to Aviation Safety Action Messages (ASAM) and Safety-of-Flight (SOF) messages. The capability of electronic transfer of data and electronic message conferencing between registered users is also available. Access can be accomplished via phone (DSN 693-9057/Commercial (314) 263-9057). Access through the Internet via File Transfer Protocol is available (FTP address is m3388f-bbs.army.mil, login as "guest"). For more details, call the System Operator, Jack Harris, DSN 693-3493/Commercial (314) 263-3493, or Co-SysOps Allan Journey or Donna Rich.

The **Olmstead Scholarship Program** encompasses the vision of military officers and their families immersing themselves in a foreign culture of choice while the officer studies a foreign language in a field of his/her choice. After the officer has completed his/her two years at the foreign university, he/she will be afforded the opportunity to attend the Command and General Staff College (CGSC) (if selected) and return to a troop assignment for field grade qualification. Officers interested in an Olmstead Scholarship must contact their Career Branch for nomination information. The PERSCOM Selection Board will meet in January 1996 and the Olmstead Foundation Board will make the final selection in April.

FEATURE ARTICLES

- 6** Branch Update — Toward the Future MG Ronald E. Adams
37 Warsteed '95: 2nd Infantry Division Style CPT Christopher E. Walach
41 Army Aviation and the Helicopter V: The H-21 Shawnee, Part II
 Dr. John W. Kitchens

SPECIAL FOCUS: FORCE MODERNIZATION

- 8** Rotary Wing Aviation Modernization Plan COL Jan E. Callen
 and LTC James W. Kelton
12 The Army Fixed Wing Modernization Plan CW5 Dave Heaton
14 Army Aviation Research, Development, and Acquisition Strategy
 Stephen M. Martinez and Bradley R. Miller

FOCUS: INTERNATIONAL ARMY AVIATION

- 21** The Canadian Forces in a Changing World MAJ James A. MacAleese
23 The Netherlands Builds an Airmobile Brigade
 MAJ Ferdinand A. Schuering
25 L'Aviation Légère de l'Armée de Terre Française en 1995
 LTG Xavier de Reviere de Mauny
27 German Army Aviation LTC Thomas H. Winter
29 The Italian Army Aviation LTC Francesco Garretto
32 Australian Army Aviation LTC Mark J. Patch

AAAA COMPANY GRADE OFFICER DIRECTORY

- 48** AAAA Company Grade Officer Directory

DEPARTMENTS

- 78** AAAA Calendar **73** AAAA News
70 AAAA New Members **68** Arrivals and Departures
3 Briefings **78** Career Track
67 Marketplace

FRONT COVER

Paid Advertisement: Boeing Defense and Space Group, Helicopters Division.
 The Boeing CH-47D Chinook is the U.S. Army's prime mover, sustaining the force into
 the 21st Century. Caption provided by Advertiser.

RAH-66 COMANCHE ROLL-OUT



The United States Army took a significant step into the 21st Century when the first prototype Boeing Sikorsky RAH-66 Comanche helicopter was unveiled 25 May 1995 at the Sikorsky plant in Stratford, CT.

Nearly a thousand spectators cheered as the prototype rolled through hangar doors and into the spotlights. The event was a major milestone in the Comanche Program.

Army Chief of Staff GEN Gordon R. Sullivan told the audience of military and industry representatives that the Comanche "is the key to winning the Information War, owning the night, and ensuring defeat to America's future enemies." Designing, testing, building, and delivering Comanche helicopters will, Sullivan said, "fulfill our sacred pledge to provide this nation's fighting men and women with the best equipment possible

to carry out their heroic missions and return safely to their homes and families. We can do no less."

The Army awarded the Comanche contract to the Boeing Sikorsky Team in April 1991. Since that time, the program has undergone a number of changes in response to modifications in funding. The current contract calls for the first prototype to fly in November 1995. A second prototype is scheduled to begin test flying the Comanche reconnaissance mission equipment package in September 1998. Six evaluation aircraft will be delivered in 2001. The Army will use those helicopters to exhaustively field test the Comanche's design and performance. Production should begin in 2005, with the first complete Comanche unit fielded in 2006. See the July issue for a complete report on the roll-out and program status from the PMO.

TOWARD THE FUTURE

You've lived it now for years — change! The Aviation Restructure Initiative (ARI), seven aviation digitization programs, Stripes on the Flight Line, new doctrinal manuals, our Force XXI Aviation Campaign Plan, Longbow, and Comanche. But with all the change, we are still maintaining a clear focus on our Aviation Force XXI objectives.

We have a balanced and sound aviation modernization strategy which addresses mission shortfalls with technology upgrades in both aircraft and core programs. I encourage you to carefully read the following articles on Army Aviation's Modernization Plan provided by COL Jan Callen and his staff at HQDA, DCSOPS, Aviation; they will provide you with an update on the direction we are headed.

25 May 1995 was truly a historic date for our Branch when all eyes were looking toward Stratford, CT, where the first operational RAH-66 Comanche was proudly rolled out. GEN Gordon R.

“A relevant modernization strategy and an integrated warfighting doctrine, combined with our soldiers, will give us the decisive edge...”

Sullivan, Chief of Staff, U.S. Army, was there to congratulate the entire team for its hard work and reiterate the necessity of Comanche — the quarterback of the digital battlefield. Make no mistake about it — Comanche is still the centerpiece of our modernization strategy.

As we focus on modernization, we must

not forget the importance of the soldiers who will actually make it happen.

Our Aviation soldiers are the best in the world — proven in both peace and combat. Modern technology will provide them an added advantage over the enemy in terms of survivability and lethality. A relevant modernization strategy and an integrated warfighting doctrine, combined with our soldiers, will give us the decisive edge on the Force XXI battlefield.

★ ★

MG Adams is the Aviation Branch Chief and CG, USAAVNC and Ft. Rucker, AL, and Commandant, USAALS, Ft. Eustis, VA.

MISSION: DETECT



■ Under darkness ... smoke ... or camouflage ... if it moves it's detected — a bright spot on your display.

AIL's airborne AN/APS-144 and ground-based AN/TPS-74 modular radars deliver high-resolution Moving Target Indicating (MTI) and cueing for manned and unmanned aircraft, ground-vehicle, and manpack applications. Proven in U.S. Army field tests, the advanced design of these small, lightweight, modular radars meets a wide range of military and civilian detection requirements.

The technology of detection — if it moves, it can be seen.

AIL has been certified as meeting or exceeding ISO 9001 standards.

For further information contact:

Business Development

001-516-595-3094

Fax: 001-516-595-6639.

AIL Systems Inc.

Subsidiary of Eaton Corporation

Commack Road

Deer Park, NY 11729 USA

AIL  **YOUR MISSION
IS OUR
COMMITMENT**
SYSTEMS INC.

ROTARY WING AVIATION MODERNIZATION PLAN

Army aviation contributes across the range of military operations. It is a deployed force which conducts operations as diverse as maneuver warfare against Iraqi armored formations to fighting forest fires in the northwestern United States. It was a key player in the clan warfare environment of Mogadishu as well as hurricane relief operations in Florida.

What is readily apparent is that whenever and wherever U.S. soldiers are called to support our Nation's vital interests, Army aviation will be there. Army aviation's versatility can also be seen through its significant contributions to each of the Army's Modernization objectives: Project and Sustain, Protect the Force, Win the Information War, Conduct Precision Strikes, and Dominate Maneuver. That is why Army Aviation's guiding premise is to field a force ready for all contingencies and equipped with the most modern warfighting systems and equipment possible.

Aviation's overall modernization strategy is to provide our nation the most capable force within resource constraints by

*"Army Aviation's
guiding premise is to
field a force ready
for all contingencies
and equipped with the
most modern
warfighting
systems..."*

executing a balanced modernization plan. Materiel modernization focus and priorities are driven by four tenets. The first of these is to solve one of the Army's most critical battlefield deficiencies — aerial reconnaissance and security operations. Next is to maintain our technological edge and world class attack helicopter capability into the 21st Century.

Another key to success is the requirement to enhance command, control, communications, and intelligence (C³I) and joint/combined interoperability through battlefield digitization.

Finally, we must sustain our utility, cargo, and fixed wing capabilities until upgrade or replacement is possible. These tenets, coupled with organization and resource constraints addressed by the Aviation Restructure Initiative, drive our requirement to reduce the rotary and fixed wing fleets to four aircraft types each. For the rotary wing fleet, the objective force will consist of: RAH-66 Comanche, AH-64D Longbow Apache, UH-60 Black Hawk, and CH-47 Chinook. (Fixed wing modernization is covered by



Helicopter **Gun/Rocket** Systems

7.62mm, .50 Cal, 40mm, 30mm, 2.75"



**CONTRACT
FABRICATION
& DESIGN, INC.**

1010 FM 546
PRINCETON, TX 75407
(214) 736-2260

FIELD A TRAINED & READY FORCE

Modernization Tenets

FIX RECON/SECURITY



RAH-66

- ✓ Survivable by Design
- ✓ Superior Targeting
- ✓ Enhanced Performance
- ✓ Low Observable
- ✓ Air Combat Capability
- ✓ Rapidly Deployable
- ✓ Speed/Range for
 - Deep Opns
 - Scout Opns w/AH-64
 - Security Opns
- ✓ Improved Reliability & Maintainability
- ✓ Shipboard Compatible
- ✓ Fully Digitized
- ✓ NBC Protection

MAINTAIN ATTACK SUPERIORITY



AH-64

- ✓ Fight in Adverse Weather & Obscured Battlefields
- ✓ Threat Stand-off
- ✓ Fire & Forget Missile
- ✓ Rapid Target Servicing
- ✓ Improved Reliability
- ✓ Crew Workload Improvements
- ✓ Fully Digitized

DIGITIZE MODERN AIRCRAFT



OH-58D



AH-64



UH-60



CH-47

- ✓ Joint Service Interoperable
- ✓ Non-Line of Sight Comm
- ✓ Global Positioning System
- ✓ Digital Target Handover
- ✓ Mission Planning System
- ✓ Enhanced C² (A2C2S)

SUSTAIN UNTIL UPGRADE or REPLACEMENT



OH-58A/C



AH-1



UH-1



CH-47



C-12 & U-21

- ✓ Safety Mods

AVIATION
RESTRUCTURE
INITIATIVE



ARI Tenets

- Reduce Logistics Requirements
- Fix Army of Excellence Deficiencies
- Stay in Resource "Box"
- Retire Obsolete Aircraft

Figure 1

CW5 Heaton in the next article.) Along with aircraft modernization, we must also continue to modernize our core programs:

- Aviation Electronic Combat (Aircraft Survivability Equipment and Avionics);
- Aviation Life Support Equipment;
- Aviation Ground Support Equipment;
- and Air Traffic Services.

At the centerpiece of our modernization strategy is the RAH-66 Comanche. Comanche's versatility, sustainability, survivability, and interoperability will ensure Army aviation's ability to contribute to future mission successes. The Comanche will acquire and process battlefield information with stealth and speed, provide accurate and timely reports to decision-makers using digital data transfer, and respond immediately to tactical situations. It is a key component of Force XXI. Additionally, the Comanche can provide firepower during early entry operations

with contingency forces and will be capable of closing undetected when scouting for the heavily-armed AH-64 Apaches. It will fix a broken mission area — aerial reconnaissance and security operations, a mission area commonly known as "armed reconnaissance".

Regarding Comanche fielding, there is a rumor abounding that Comanche is "dead". Nothing could be further from the truth. In December 1994, Secretary of Defense Perry released Program Decision Memorandum IV. This document reduced the Comanche program from three flyable prototypes down to two during the Program Objective Memorandum (POM) FY96-01 period and deferred production of the aircraft. To evaluate the impact of PDM IV, Department of the Army directed a reassessment of the aviation modernization strategy. MG Ronald E. Adams, CG USAAVNC; MG Dewitt T. Irby, Jr.,

PEO Aviation; and MG John S. Cowings, CG ATCOM entered into a full court press and the results of their review were briefed in the Pentagon on 17 January 1995.

It became apparent to Army decision-makers that there was no cost-effective alternative to the Comanche (a conclusion the Office of the Secretary of Defense had previously arrived at during the 1993 Bottom Up Review). In fact, during a February 1995 Requirements Review Council, GEN Gordon R. Sullivan, Chief of Staff, Army (CSA) expressed his commitment to Comanche and concurred with an innovative development plan. This plan, developed by the Comanche Program Manager, will put six demonstration aircraft into an Army unit by the turn of the Century for two years of evaluation by the unit.

The CSA and the Secretary of the Army reaffirmed the commitment of the entire Army to the Comanche in a jointly-signed 7 February 95 memo which stated, "... Comanche ... continues to be our number one long term system for the Army of the 21st Century." Additionally, in a recent Acquisition Decision Memorandum, the Under Secretary of Defense for Acquisition and Technology approved proceeding with the restructured program.

Until Comanche is fielded, the OH-58D Kiowa Warrior provides an improvement over unmodernized Vietnam-era scouts. Equipped with electro-optical target acquisition, this aircraft has night fighting and armed reconnaissance capabilities not possessed by the OH-58A/C and AH-1 scout teams. The Kiowa Warrior will serve as an interim armed helicopter, but does not have the capabilities or growth potential required for 21st Century armed reconnaissance missions.

Another key player in our moderniza-

tion strategy is the AH-64D Longbow Apache. The Longbow will give the Army a more survivable, capable attack helicopter. It represents a quantum leap in lethality, massed firepower, and warfighting in adverse weather and battlefield obscurants. The Longbow's millimeter wave Fire Control Radar, fire-and-forget Hellfire missile, precision identification of threat radio-frequency emitters, cockpit management, and joint interoperable digital battlefield awareness and management enhancements give the Army attack helicopter superiority into the next century. Initial Operational Test and Evaluation was completed in March 1995, and the procurement decision is scheduled to be made in October 1995. The result should be a First Unit Equipped date of September 1997.

To maintain a balanced modernization strategy, we must also continue to procure UH-60 Black Hawks to displace the obsolescing UH-1 fleet. The UH-60 is a solid performer with excellent deployability, survivability, and maintainability. This workhorse of Army aviation has proven itself in combat from Grenada to Somalia. Unfortunately, over the last two years budgetary pressures have forced the Army to terminate procurement of Black Hawks during the POM period, leaving us with a shortfall of 676 aircraft after the current production ends. This has forced us to retain UH-1 aircraft in lower priority units. The Army's position is, this is untenable; we will pursue an affordable plan to procure more Black Hawks during the mini-POM FY 97-01 process.

By the same token, we must have a follow-on aircraft for our aging CH-47D Chinook fleet. The CH-47 will approach 40 years of age at the turn of the Century. Its eventual replacement is envisioned (MOD PLAN — continued on p. 64)

THE ARMY FIXED WING MODERNIZATION PLAN

The Army's fixed wing fleet consists of 21 different types of airplanes performing a multitude of missions, while supporting a host of users. This diverse and varied fleet has become increasingly difficult to manage, modernize, and is expensive to operate and sustain. Additionally, the lack of a standardized fleet and the numerous cockpit configurations represented by 21 different types of airplanes have an adverse impact on training and standardization.

Failure to follow the Army's system for determining requirements has caused the problem. All Army utility fixed wing bought since 1981 have been a result of directed procurement. Although loosely tied to a requirement, the primary thrust has been the equitable distribution of aircraft procurement contracts to various aircraft manufactures. The Army's fixed wing modernization strategy clearly articulates our needs to those who can assist us in standardizing the fleet. Like the rotary wing strategy, the fixed wing

The fleet will be reduced from 21 different types of aircraft to four.

plan is evolutionary and focuses on four basic aircraft types to satisfy four basic requirements.

The modernized fleet will consist of short (0-500 nautical mile), medium (500-1800 nm), and long range (1800+ nm) utility aircraft (C-XX SR, MR, and LR) and a conceptual Multi-Mission Medium Tactical Transport (M³T²).

The Army currently has two aircraft on hand that will meet the plan's short range and long range requirements, the C-12 and C-20, respectively. We are gradually replacing our aging, 27 year old, unpressurized U-21 aircraft with the C-12 and are performing the long range mission with a limited number of C-20 aircraft.

After evaluating mission profiles from operations DESERT SHIELD/STORM and Hurricane Andrew disaster relief, a shortfall in the medium range requirement was identified. The C-12, with its limited range and speed, is not a cost effective aircraft for the medium range mission. Cost comparisons by the Army's Aviation

FIXED WING MODERNIZATION PLAN

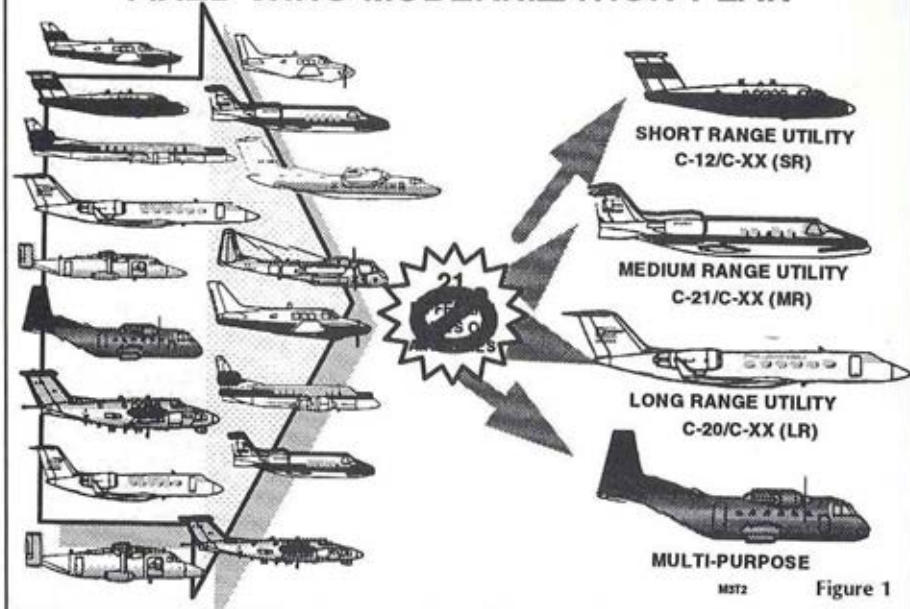

and Troop Command indicate the medium range missions would best be filled by a turbojet versus a turboprop aircraft. Currently, the Army is attempting to obligate congressional dedicated funds to identify an aircraft to fill the C-XX MR requirement.

Subject to funding delays, full and open competition for the aircraft will begin during first quarter FY96, with a contract awarded during the second quarter FY96. Today, the Army has a requirement for 29 C-XX MR aircraft and procurement of the C-XX MR is the Army's highest fixed wing priority.

Also identified as a shortfall is the need for a single common tactical platform to satisfy multi-mission requirements. Although not mature enough to be a stand-alone program, a single cost effective multi-mission tactical fixed wing

aircraft is a valid concept. Today, Airborne Common Sensor requirements and the intra-theater cargo mission appear to have mission profiles compatible with a Multi-Mission Medium Tactical Transport (M^3T^2).

The Army's Fixed Wing Modernization Plan is a coordinated, cost effective, fixed wing modernization strategy. The plan represents all Army fixed wing user requirements while limiting the number of different types of fixed wing aircraft in our inventory. If funded, the fixed wing modernization plan will equip America's Army to meet its 21st Century fixed wing requirements.

★ ★

CW5 Heaton is the Fixed Wing Systems Integrator, DDCSOPS, Washington, D.C.

ARMY AVIATION RESEARCH, DEVELOPMENT, AND ACQUISITION STRATEGY

The Research, Development, and Acquisition (RDA) strategy of the 1995 Army Aviation Modernization Plan (AAMP) involves four process steps: sustain, improve, develop and procure, and retire aircraft.

The first step evaluates the current fleet's capability to meet warfighting requirements. If it meets required needs, the fleet is sustained by safety and reliability, availability and maintainability (RAM) upgrades to achieve operation and support cost reductions and improved sustainability. The second step looks to improve existing systems, staying inside potential opposing force capabilities through technology insertion and integration.

When neither upgrades nor technology insertions can provide required capabilities, or the cost-benefit ratio is too high, the strategy looks to new systems for development and fielding. As this occurs, old and technologically obsolescent aircraft are retired. Inherent in this process is the development of aviation science and technology to enhance aviation capabilities in the next century, and provide the en-

The blueprint for the 1995 Research, Development, and Acquisition portion of the AAMP.

abling capabilities for future systems.

The austere FY 96-01 POM funding and the PDM IV decision regarding the Comanche program are critical drivers of our Army Aviation RDA strategy (Figure 1). The objective of this strategy is to apply our limited resources in a manner which maximizes return on investment.

Reconnaissance & Security. The U.S. Army remains committed to the RAH-66 Comanche as the centerpiece of its aviation modernization strategy. It is a key component of the digital battlefield. An alternative acquisition strategy to provide two prototypes and six Early Operational Capability (EOC) aircraft was briefed to GEN Sullivan and approved by OSD. Despite the setback of PDM IV, our strategy continues to focus on the replacement of the Vietnam-era AH-1 and OH-58A/C: in the interim with OH-58D Kiowa Warrior (mid-term) in high priority units and RAH-66 (far-term) in all units. The modification of 382 OH-58D to the Kiowa Warrior configuration (Hellfire, Stinger, rockets, .50 caliber

**LASER
BORESIGHTING:
ANY PLATFORM,
ANY CONDITION,
ANY TIME.**

Rugged, reliable and extremely accurate, Photonics Corporation's Joint Service Multi-Platform Boresighting Equipment (MPBE) is already in production for U.S. services and international military forces.

Photonics's single-beam, laser-based system provides:

- Continuous, simultaneous measurement in all three axes.
- Platform harmonization (0.9 milliradians or better) in less than one hour.
- An MTBF greater than 1700 hours - demonstrated.
- MIL-qualified, flight deck qualified boresighting on land or at sea, night or day, in any weather.
- The lowest training, inventory and depot calibration requirements of any system in the world.

For more information, please contact Photonics Marketing, 270 Motor Parkway, P.O. Box 11368, Hauppauge, NY 11788, 516-231-9500. Telex: 510-227-9867. Fax: 516-231-9501.



"The Joint Services boresighting system of the future is here, proven, and available now—from Photonics."







**DRS PHOTONICS
CORP.**

A Subsidiary of Diagnostic/Retrieval Systems, Inc.

Richard Ross
President, Photonics Corp.

Figure 1

RDA Resourcing

- | | | |
|---------------------------|---|--|
| RAH-66 |  | <ul style="list-style-type: none"> • Only 2 Prototypes in POM • Production Deferred Beyond FY01 |
| AH-64D |  | <ul style="list-style-type: none"> • Modification Begins FY 95 (Ramps to 72 Act/Yr) • Procures Longbow Hellfire Modular Missile System • Begins Funding Longbow Apache Tactical Engagement Simulator System |
| AH-64A |  | <ul style="list-style-type: none"> • RAM & Operation Desert Storm (ODS) Fixes Which Also Support AH-64D Upgrade • Funds TADS/PNVs and Category B Trainer Upgrades |
| UH-60 |  | <ul style="list-style-type: none"> • Minimum Mods to Refurbish/Standardize Pre-1989 UH-60A's • Terminates Procurement After FY 96 |
| OH-58D |  | <ul style="list-style-type: none"> • Completes Kiowa Warrior Upgrades • Procures Multi-Purpose Light Helicopter Mission Kits |
| CH-47D |  | <ul style="list-style-type: none"> • Provides Only Safety and ODS Fixes - Follow-On Deferred • Continues to Study Alternatives for Cargo Fleet Post-2000 |
| Fixed-Wing Utility |  | <ul style="list-style-type: none"> • Very Low Rate of Avionics Upgrades (Standardizes C-12) |
| Core Programs |  | <ul style="list-style-type: none"> • Meets Most Critical Requirements for Avionics (Top 6 for Digitization) • Continues ASE Efforts for RF and IR Countermeasures • Sustains Efforts to Modernize AGSE & SKO • Moderate Level of Effort for Tactical ATC, Stretches Fixed-Base/NAS |
| S&T Program |  | <ul style="list-style-type: none"> • Sustains Critical Rotary-Wing Technologies (Rotorcraft Pilots Associate, Advanced Platform Technologies, Joint Technology Advanced Gas Generator) |

machine gun) will be completed in 1998. Selected Multipurpose Light Helicopter kits are also being procured. Follow-on upgrades include incorporation of fleet standard digital systems and RAM and Enhanced Performance (RAMEP) R2 engine upgrade.

Attack. The mid- and far-term objective is to modify 758 AH-64A to the AH-64D Longbow Apache. This requirement may be less than the far-term fielding requirement, depending on RAH-66 distribution decisions. Under the interim force design of ARI, one-third of the AH-64D aircraft must perform the scout role. To this end, we will equip 227 AH-64Ds with the Longbow mast-mounted millimeter wave (MMW) Fire Control Radar. All aircraft will receive total electronic integration, precision inertial and GPS navigation, state of the art weapon system and display processors, human factors designed cock-

pit, joint compatible digitized communications suite, fully automated maintenance manuals, and aircraft reliability improvements. AH-64As will be modified with Operation DESERT STORM identified fixes and RAM modifications, prior to modifying to the AH-64D.

Utility. Modernizing the utility fleet requires 2,045 UH-60 (not including SOA or SEMA) and 131 light utility helicopters (LUH) for light cargo, liaison, courier, command support, general support, and other secondary tasks. The POM terminates UH-60 procurement after FY 96 at 1,390 aircraft (not including SOA and SEMA), requiring about 900 UH-1 helicopters to remain in the fleet. Modernization of the UH-60 continues with the standardization of pre-1989 A-models (300) to the 1989 A-model baseline configuration, and digitization, electromagnetic environment protection and im-

proved radar warning upgrades. Upgrade of selected UH-60s with the Army Airborne Command and Control System (A2C2S) will provide commanders an effective, integrated, interoperable, airborne C2 system. Alternatives for unresourced LUH requirements include UH-1 with service life extension program (avionics/wiring upgrade), commercial off-the-shelf aircraft, or UH-60.

Cargo. The CH-47D meets current cargo aircraft requirements. The force structure requires 488 CH-47Ds (not including SOA). CH-47D procurement is completed with the acquisition of 444 CH-47Ds. The CH-47D modernization program extended aircraft life by approximately 20 years, so that aircraft begin to reach the end of programmed life in FY 02. The objective is an upgrade/service life extension or replacement, depending upon out year funding. Studies are underway to define CH-47D upgrade requirements. Upgrades to the CH-47D may include digitization, extended range fuel tanks, and engine/rotor components. An envisioned joint service replacement, the Advanced Cargo Transport (ACT), is in early stages of concept development. The National Transport Rotorcraft (NTR) program is an S&T effort focused on technologies for a potential replacement aircraft (i.e., ACT) or CH-47D upgrades, as well as commercial transports.

Utility Fixed Wing. The approved Fixed Wing Investment Strategy details the modernizing strategy for the utility fixed wing (see the prior article by CW5 Heaton).

Core Programs. Essential to the support and sustenance of our major aircraft programs are "core" programs that provide required mission and support equipment, as well as upgrades or new technologies that ensure the mission capabilities and operational supportability of these

aircraft. The core programs include Aircraft Electronic Combat (includes Aircraft Survivability Equipment (ASE) and Aviation Electronics (Avionics), Aviation Ground Support Equipment (AGSE), Aviation Life Support Equipment (ALSE), and Air Traffic Services (ATS). Unfortunately, these core programs are under funded and our priority is based on aircraft mission requirements and Department of the Army Master Priority List (DAMPL) sequence.

The ASE program includes radio frequency (RF), infrared (IR), and electro-optical (EO) countermeasure devices to detect and defeat threat anti-aircraft systems. As Army aviation continues to modernize, aircraft systems must have necessary ASE items installed at the production line or via field retrofit. Advanced Threat IR Countermeasures (ATIRCM) and Suite of Integrated Radar Frequency Countermeasures (SIRFC) are the two most critical ASE programs for Army Aviation electronic warfare. They provide robust situational awareness, improved target identification, interfaces for digital target handover, missionized electronic order of battle, and substantially improved aircraft survivability.

The fully integrated modular architectures and digital interfaces permit application to existing and next generation aircraft (i.e., AH-64D and RAH-66). The ATIRCM replaces the current AN/ALQ-144, AN/ALQ-156, and M-130 federated architecture IR countermeasure systems with a modular, reconfigurable IR countermeasure system to defeat current and projected IR threat missiles. The SIRFC program replaces three aging systems: AN/ALQ-136 pulse radar jammer, AN/ALQ-162 continuous wave radar jammer, and AN/APR-39 radar warning receiver.

The SIRFC is a lightweight RF system

using an integrated, modular architecture that consolidates warning and jamming functions. The SIRFC provides the receiving assets, signal identification, target location, and active ECM transmissions for the integrated RF system elements. The SIRFC CPU provides sensor fusion algorithms for mission equipment and EO/IR/RF threat data correlation, threat identification, location, and assessment decision tools for coordinated multi-spectral countermeasures response, suite resource management decisions, and digital target handover interface for the combined ATIRCM/SIRFC suite. Initial production for both systems is scheduled in FY 99.

The avionics program addresses digital battlefield capabilities to ensure aviation meets combined arms and joint requirements for communications, navigation, information interchange, and target handover; that the avionics components are compatible, interoperable, and supportable; and, that optimum use is made of common and synergistic components. The avionics acquisition strategy maximizes the use of NDI and off-the-shelf components. Programs include: GPS; AN/ARC-220 Nap-of-the-Earth Communications High Frequency Radio; AN/ARC-164 Havequick II radio; Improved Data Modem; A2C2S; Aviation Mission Planning Station (AMPS)/Data Transfer System; Aviation Tactical Operations Center (AV-TOC); simulation; and imagery.

The AGSE program develops and procures GSE; Sets, Kits and Outfits (SKO); and cargo handling equipment. The program maximizes the use of NDI for materiel development and acquisition. Major efforts include: the Shop Equipment-Contact Maintenance vehicle; Advanced Boresight Equipment; the Soldier Portable On-System Repair Tool; the Unit Level Logistics System-Aviation; and the divi-

sional and non-divisional AVIM shop set complexes. We are currently examining different programs for modularity of AVIMs. The ARI and changes to ARI are also being examined with regard to modularity and the impact on the basis of issue for GSE, SKO, and Materiel Handling Equipment (MHE). The Advanced Aviation Forward Area Refueling System will provide more reliable, rapid, and safer tactical refueling of aircraft capabilities. MHE for ammo and fuel handling is essential to tactical warfighting enhancements. Cargo handling-equipment improvements use new technologies and concepts for cargo loading, off-loading, and transportability for potential application to the CH-47 (FO), NTR, or ACT.

The ALSE program encompasses items of equipment needed to protect, sustain, and enhance the performance of Army aircrews and passengers, on the ground and during flight. ALSE enhances mission performance and aircrew survivability during operational missions, in crash situations, and in post crash/prior to rescue conditions. The ALSE program includes: helicopter crew restraint and air bags systems; new and P3I helmets; laser eye protection for near/far-term IR/laser threats; NBC protection and warning systems; aircrew micro climatic cooling system; helicopter oxygen system; and survival kits (includes flotation devices, survival vest, and life sustaining materiel).

The joint service Air Warrior program, a derivative of Land Warrior, addresses unique aircrew requirements. It integrates multiple ALSE technologies into a system for the aircrew, defines aircraft integration to ensure overall functional interface, enhances crew performance, and reduces unit and life cycle costs of currently fielded items of ALSE.

To support Army and worldwide commitments, ATS must be capable of sup-

Aviation S&T Program

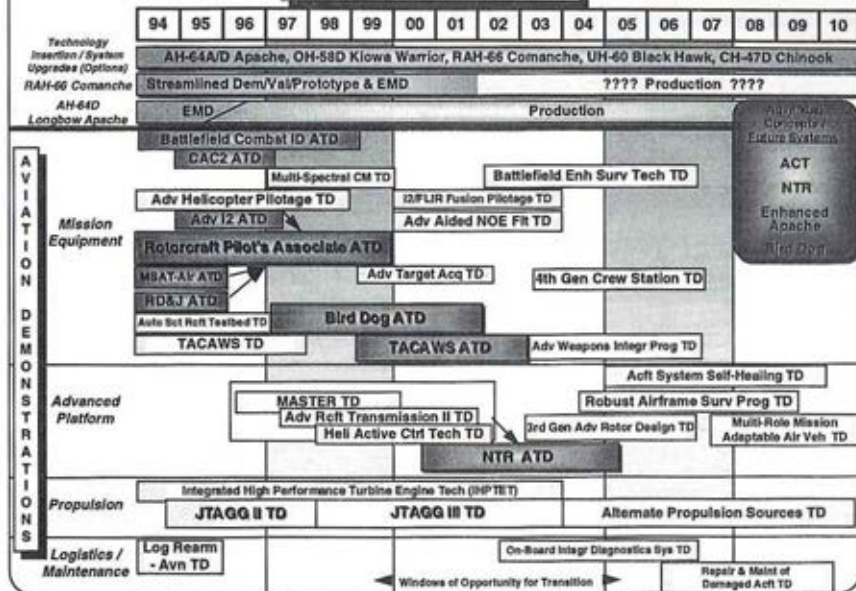

Figure 2

porting various types of aircraft across the entire operational continuum. As new systems and technologies are inserted in the aviation fleet, ATS concepts, doctrine, and systems must keep pace. Operational requirements for Air Traffic Control hardware focus primarily on ATS support of Army Airspace Command and Control. Four tactical ATS systems are funded for development and acquisition: the Tactical Terminal Control System; Air Traffic Navigation, Integration, and Coordination System; Tactical Airspace Integration System; and Mobile Tower System.

Fixed base ATS supports joint, combined, and individual services training and provides equipment to support force projection deployment airfields. In concert with FAA programs to modernize the National Airspace System, fixed base facilities will be upgraded for NAS integration so they are transparent to the user.

Munitions. The Hellfire II and RF Longbow Hellfire missiles are complementary systems for the AH-64D and RAH-66, and permit precision engagements in electro-optic countermeasure environments and adverse weather. The Hellfire II has an enhanced laser seeker, is countermeasure hardened, and has an improved lethality warhead. The Longbow Hellfire uses the same airframe as the Hellfire II and incorporates a MMW seeker. Concepts are being evaluated for an advanced, low cost, precision guided munition (to replace the Hydra-70 family of rockets and supplement Hellfire) to provide a cheaper, more capable means of defeating non- or lightly armored targets. The Army's Combined Arms Weapons System (TACAWS) is an Advanced Technology Demonstrator (ATD) effort to develop a common combined arms missile to replace TOW and Stinger.

Procurement Objectives
President's Budget / FY96-01 POM

Airframe	Fiscal Year							Total Thru POM	Procurement Objective
	95	96	97	98	99	00	01		
AH-64A								821	821
AH-64D		18	26	37	48	53	52	234	758
OH-58D	17							383	383
RAH-66	1			1			6	8	1292
UH-60	60	60						1390	1390
CH-47D								444	444
Cost (\$B) (Aviation TOA)	1.9	1.5	1.2	13	1.5	1.6	1.7	* No Production-Prototypes only	

UH-60A Does Not Include 66 EH-60s, 60 SOA (MH-60)

UH-60 Total Includes 93 Unavailable Aircraft (48 Atrilled, 16 USAF, 18 Customs, & 10 Security Asset Pgm Xfers)

CH-47D Does Not Include SOA (26 MH-47E, 11 MH-47D)

AH-64D figures are upgrades to existing AH-64A airframes; no new buys

Figure 3

Aviation, Science, and Technology Program. The aviation S&T develops the foundation for aviation's system upgrades and next generation/future systems capabilities to meet changing threats, mission requirements, and to support the modernization strategy. Through the tri-service Project Reliance and Joint Aeronautical Commanders Group, the aviation S&T program is the DoD lead and focus for rotorcraft technologies. The Army Science and Technology Master Plan details the S&T strategy for aviation.

Figure 2 shows the interrelationship between aviation disciplines, Technology Demonstrations (TD), and ATDs. The Aviation S&T program addresses issues including: aeromechanics; flight controls; structures; human-machine crew integration; survivability; and advanced concepts for DoD rotorcraft. It addresses these via application of DoD, NASA and academic

resources, simulation, virtual prototyping, and Integrated Product and Process Development which reduce risk, minimize costs, and enhance multi-service and dual-use applications.

The key Aviation ATDs are Rotorcraft Pilot's Associate (RPA), Multi-Sensor Aided Targeting-Airborne (MSAT-Air), and Radar Deception and Jamming (RD&J). Current TDs that are candidate ATDs include: Bird Dog (a concept for a manned helicopter and UAV team), NTR, and TACAWS. The technology demonstrations in support of NTR address airframes, structures, rotors, and transmissions. Key TDs are: Joint Turbine Advanced Gas Generator (JTAGG), Manufacturing and Structures Technology for Efficient Rotorcraft, Helicopter Active Control Technology, Advanced Rotorcraft Transmission, Autonomous Scout Rotorcraft (STRATEGY — continued on p. 67)

THE CANADIAN FORCES IN A CHANGING WORLD

The past two years have marked a significant turning point in the history of the Canadian Armed Forces. Responding to a fundamental reordering of international affairs, as well as the need to confront economic realities at home, the Prime Minister of Canada ordered a comprehensive review of Canadian defence policy. This led to the establishment of a Special Joint Committee of the Senate and House of Commons to consult with the Canadian public and various organizations on this issue.

The report from the Special Joint Committee played an integral role in the shaping of Canadian defence policy as most of its recommendations were reflected in the Defence White Paper of December 1994. The final result of this review was an effective, realistic and affordable defence policy, one that calls for multi-purpose, combat-capable forces able to meet the challenges to Canadian security both at home and abroad.

The military was not exempt from the battle to reduce Canada's financial deficit. The 1994 White Paper will be implement-

*Downsizing,
realignment,
and
new aircraft
are all part
of the
picture.*

ed with a reduced budget, but more resources will be put into producing essential combat capabilities and less into infrastructure and support. Highlights of the 1995 Federal Budget included reductions in the following areas:

- personnel reductions to 60,000 Regular Force and 23,000 Primary Reserves by 1999;

- bases closures and reductions to align the infrastructure with the requirements of the reduced force;

- development of a new command and control structure to reduce headquarters resources by one-third, including the elimination of some levels of command; and

- reduction in the cost of fighter operations by 25% through retirement of the CF-5 and reduction of the CF-18 fleet.

There is some good news though. Despite personnel reductions, the Land Forces will be increased by approximately 3,000 combat personnel, made possible through reductions in headquarters and restructuring of the three services. As well, 10 Tactical Air Group (TAG), the army aviation branch of the Canadian

Forces, is in the process of upgrading to a new helicopter that will allow it to meet the aims of the new defence policies.

In Canada's integrated Armed Forces, 10 TAG is one of the air force's four functional Air Groups. Although under command of the air element, the Group is under operational control of the land force. 10 TAG consists of three wings and ten squadrons, geographically located to support the major land formations. This will change in the near future as the restructure will see some of the headquarters functions move to the Air Combat Mobility Group headquarters being formed next year by amalgamating the fighter, transport, aviation and possibly maritime air headquarters. However, this group downsizing three wings to one will not affect the resources available to support the land forces.

On 5 April 1995, 10 TAG took the first step in the move to the 21st century with the acceptance of its first CH-146 Griffon helicopter. Over the next three years, 10 TAG will receive 89 Griffons to replace the current fleet of OH-58A and UH-1Ns. The Griffon is a derivative of the Bell 412EP, a helicopter with a proven design that has evolved over 30 years.

The acquisition of this helicopter has made significant changes to the way business will be conducted. The Griffon is essentially a commercial helicopter that has been militarized with options such as NVG compatible cockpits and fully integrated avionics and ASE suites. The aircraft will maintain a commercial certificate and practices will be used where possible to exploit many commercial advantages. Commercial manuals and

maintenance procedures will be used and, except for unique equipment, spare parts will be provided directly to units through Bell's Customer On-line Ordering Process (CO-OP) system. Despite encountering minor problems adapting a commercial product for military use, deliveries are proceeding on schedule.

It has been recognized that the ability to conduct missions normally carried out by the OH-58 will be reduced or eliminated by going to a single fleet but this is more than compensated for by the improved capability this fleet will bring to 10 TAG. The avionics and ASE packages will ensure the aircraft has a place in the digital battlefield of the future.

The enhanced utility lift capability will not only better serve the army in war, but will also allow for improved peacetime support to national tasks that traditionally are better suited to utility helicopters. This secondary role has included such tasks as search and rescue, disaster

relief, counter drug operations, VIP transport and peacekeeping operations.

The road ahead for army aviation in Canada will no doubt have some rough sections. Many tough decisions have been made and more will be necessary as realities of the present world are faced. However, a restructured force and a new helicopter will ensure 10 TAG is able to maintain a flexible and multi-purpose capability able to operate well into the next century.

★ ★

MAJ MacAleese is the Canadian Liaison Officer to the USAAVNC.

"10 [Tactical Air Group] consists of three wings and ten squadrons, geographically located to support the major land formations."

THE NETHERLANDS BUILDS AN AIRMOBILE BRIGADE

Since the world has changed faster and more drastically than could have been foreseen, so have the sizes and structures of armed forces. In the Netherlands, this resulted in a complete review of the Defense Forces in 1991.

After this review the following tenets were formulated for the Dutch contribution to ensure international stability and

to participate in both peacekeeping and legitimate peace-enforcing operations:

- In view of the diversity of risks and threats the Netherlands must in principle be prepared and able to contribute to a broad spectrum of peacekeeping and peace-enforcing activities in an international context.
- The Netherlands will invariably make its forces available in international cooperative contexts.
- In the event of a direct threat to the territory of the Netherlands, or the NATO treaty area, their defense will receive the highest priority.
- All combat-ready Dutch units can in principle be made available to international peacekeeping and peace-enforcing

*The focus is
peacekeeping and
peace enforcement
in the
international
context.*

operations (Netherlands Armed Forces are now participating in nine different UN missions from small detachments to an infantry battalion in former Yugoslavia).

This review resulted in a reduction of forces but at the same time, an increase in mobility and flexibility was announced. Within this scope, priority was given to form an Air Mo-

bile (Air Assault) Brigade. This brigade is a part of the NATO Multinational Division (Central) (MND(C)) together with brigades from Great Britain, Germany and Belgium. MND(C) is a part of the new NATO Rapid Reaction Forces (RRF) as well as ACE Rapid Reaction Corps (ARRC).

The air mobile brigade of the Royal Netherlands Army consists of a ground component and an air component.

Ground Component. The ground component consists of three infantry battalions, a mortar company, an engineer company, a supply company, a maintenance company and a medical company. This component will be fully operational within a few months.

An important difference with a U.S. Army air assault brigade is that the air mobile brigade has no artillery, with only 81mm mortar, 120mm mortar, Stinger, TOW, and Dragon available. The Attack helicopters are the main source for fire power.

Air Component. In order to fulfill the requirement to transport the operational part of one battalion of the brigade during one lift over a distance of 230 km, the following orders have been placed:

- 13 Boeing CH-47D international Chinook helicopters (MTH);
- 17 Eurocopter AS-532 U2 Cougar Mark 2 (LTH), and;
- 12 BO-105 light utility helicopters are already in service.

To provide fire support, armed recon and escort 30 AH-64D Longbow Apaches (without radar) are ordered and will be delivered from 1998 on. Twelve U.S. Army AH-64As will be made available for training next year.

This air component is a part of the Royal Netherlands Air Force (RNLAf) but is primarily dedicated to the air mobile brigade of the Army.

The first delivery of the Chinooks starts this year. They will have an Avionics Control Management System (ACMS) developed by Honeywell. They will be the first outside the U.S. Army's 160th Special Operations Aviation Regiment with a digital "glass" cockpit, 1553B databus, and integrated avionic architecture. The ACMS is very different from the IBM Integrated Avionics Subsystem in the Special Operations MH-47E. The navigation system will include an Inertial Navigation System, GPS receiver and ASN 128 Doppler, all tied to a Kalman filter to pick the most accurate solution.

The Eurocopter AS-532 U2 Cougar Mark 2 will enter service in the Netherlands next year. It is the newest develop-

ment in the Puma series helicopters. It has a better payload and range than its predecessors, due to the Spheriflex main rotor head and rotor blades with extended tips and a new shape. The cockpit features a new instrument panel with four large electronic flight instrument system (EFIS) displays and a digital, dual duplex automatic flight control system. Featuring a larger cabin than previous Super Pumas, the Mark 2 can carry a two-man air crew and up to 29 troops or nine stretchers in an air medical configuration.

Training. The RNLAf faces a tremendous challenge to train air crew and ground personnel in these new helicopters. To accomplish this, the RNLAf will establish a Tactical Training, Evaluation, Standardization and Simulation Office with operational experts for each type of helicopter. Exchange pilots from the U.S. Army and Great Britain will be of great value to assist in training and the implementation of the air component in the air mobile brigade.

For one and a half years three instructor pilots and three flight engineers of the RNLAf have been getting experience on the CH-47D at Fort Rucker. They perform daily Instructor Pilot and Flight Engineer duties at F Co, 1-14th Avn Regt based at Hanchey Army Heliport.

At the same time in France, three instructor pilots are getting experience on the Cougar with the French Army.

All new helicopters will be in or will enter service in 1998. By that time the Netherlands forces will have an air mobile brigade, equipped with the most modern equipment available today, to meet the challenges of a turbulent world.

★ ★

MAJ Schuurig (RNLAf) is the Netherlands Liaison Officer to USAAVNC, Ft. Rucker, AL.

L'AVIATION LÉGÈRE de l'ARMÉE de TERRE FRANÇAISE en 1995

The French Army Aviation (FAAVN) has a work force of close to 7,700, of which 700 are officers and 3,300 are NCOs. All personnel have been selected through a very demanding qualification process.

FAAVN includes 670 helicopters of three generations. The first generation aircraft, 170 Alouette IIs and IIIs, are being progressively retired. The second generation is the main body of the FAAVN fleet, 470 aircraft which are SA-341/342 Gazelles and SA-330 Pumas. The third generation includes the most recent aircraft, AS-352 Cougars and AS-555 Fennecs.

Nine fixed wing aircraft, two of them twin engine, complement the fleet by performing liaison, logistic transport, and target towing missions.

FAAVN is organized around the following three pillars:

Training. The branch school (EAALAT) is in charge of teaching all technical and tactical skills for pilots and aircraft captains from two training bases in Dax and Le Cannet des Maures.

After training, skilled aviators are able to report directly to an operational unit,

French Army Aviation is designed for a dual role: quick response combat and peacetime relief missions.

since they have been trained in all types of flight skills, and for combat flight in particular.

In combat flight, the French concept is to consider the helicopter not as an aircraft flying above the terrain, but as a ground vehicle moving within the features of the terrain. The crews are trained in analyzing the terrain as they fly, determining enemy

positions and capabilities. They can determine itineraries and paths offering the best security to their movements, and choose routes and safe trajectories that avoid ground obstacles.

Combat flight adds stealth to the helicopter's movements and unpredictability, thus turning the helicopter into an instrument of surprise while providing the best protection.

Combat Aviation. Combat Aviation consists of the 4th Airmobile Division (4th DAM) and the 3rd Airmobile Brigade (3rd BAM). The division includes four combat helicopter regiments, one support regiment, and one airmobile infantry regiment. The crews are trained for landing on ships and these regiments are therefore able to operate from heli-

copter carriers.

The brigade includes two combat helicopter regiments trained to operate with armored cavalry battalions from 3rd Corps. But all these aviators from the 4th DAM or 3rd BAM are interchangeable.

Command Support and Liaison Missions. Command Support and Liaison Missions are the third pillar of FAAVN. This pillar is undergoing restructuring and is under consideration for being equipped with fixed wing aircraft.

FAAVN has a twofold role:

- Providing quick-response, lethal fires in a wartime environment
- Deploying its specialized assets for assistance and relief missions of any kind.

FAAVN therefore has a permanent dual posture, which allows it to concentrate assets in case of a major conflict and to share them out into theaters of operation for limited crisis.

To this end, the modular organization of the combat helicopter regiment is a benefit. With one scout helicopter company, one escort helicopter company, three attack helicopter companies, and one tactical transport company, the commanding officer is able to combine all their functions to develop an autonomous airmobile combat operation, or tailor them for a combined support action.

All units can deploy by air, by sea, or self-deploy. In the latter case, if the itinerary is at sea, aircraft carriers are used en route as support bases for refueling, requiring only short stops on board.

The future of FAAVN will be determined by the fielding of the Tiger and NH-90 helicopters, which are very advanced aircraft developed through cooperation within Western Europe.

For the Tiger, FAAVN has refused to accept the concept of a heavy and difficult to operate multipurpose aircraft, whilst the crew is tasked for missions of very

different types. The choice was made, based on past experience, to field two different weapon systems derived from a single airframe: One is dedicated to attack missions with anti-tank missiles, and the other is dedicated to combat support missions with rockets and 30mm gun. With that in mind, the crew specialize in the specific missions of their weapon system and utilize the best of its capabilities.

The NH-90 is a medium size cargo helicopter that offers an excellent trade-off of payload and maneuverability in order to provide tactical transport and intimate logistic support to Tiger units.

With the strength of the experience obtained throughout 40 years in many theaters of operation and the suitability of its new aircraft to its specific airmobile concept, FAAVN — which has the dimensions of a separate branch without yet being one — has the ambition to remain a main asset to airland combat.

★ ★

LTG de Reviere de Mauny is the Commanding General, Army Aviation Command, and Inspector General of Army Aviation, France.

**INTERNATIONAL LIAISON PILOT
AND AIRCRAFT ASSN (ILPA)**

16518 Ledgestone
San Antonio, TX 78232



"LIAISON SPOKEN HERE"

Bill Stratton - Editor
210-490-ILPA (4572)
Send For A Free Copy
Of The Newsletter

GERMAN ARMY AVIATION

*The goal is to
conduct operations
either in conjunction
with ground forces
or as an
independent
force.*

Since reunification, the Federal Armed Forces of Germany have been subjected to significant changes, particularly in their mission and organization.

On the one hand, due to the draw down of the military, fewer forces are available to cover an extended mission area (territorial defense), and on the other hand an extended mission spectrum (everybody speaks of "new tasks") within a NATO frame or under a UN mandate has to be covered. Therefore, mobility and flexibility of forces to enable military leaders to quickly establish and shift points of main effort, and to overwatch larger areas, are becoming more and more important.

This fact serves to highlight the importance of air mobility and Army Aviation. The process to shape the Bundeswehr for the new mission spectrum is still not complete. First of all it was necessary to deactivate the former East German military and to reorganize forces to include the new Eastern States of Germany. This had to be accomplished at the same time as a draw down to 370,000 troops. There-

fore, the current Army Structure 5 is only an interim solution and is not yet the answer to the new mission spectrum.

Recent decisions taken on force structure will enable the transitional phase for the Bundeswehr to be overcome. The restructuring will begin in 1996 and is expected to be completed by the year 2000. The aims and objec-

tives of German security and defense policy, in accordance with alliance objectives, were finally transformed in a new Armed Forces Structure Plan.

Current Situation. The current situation is characterized by Army Aviation units with helicopters devoid of any kind of self-defense armament, powerful sensors, or survivability equipment. This is due to the limited, supportive role Aviation played within the overall system of the Army up to now. Some of the helicopter types currently in the inventory have been in service for so long that their original service lives have come to an end, thus making it necessary to implement service life extension programs.

The helicopters presently available are

configured for temperate climates and for operations in Germany within a Corps area; they require modification for service under different, and sometimes extreme, conditions. In other words, for national defense roles in concert with our NATO partners, we were appropriately structured and equipped, but the fixation on the previous NATO General Defense Plan has created shortcomings which are impeding the ability to take on new roles.

The Goal of Airmechanization. The long-term goal in the process of developing German Army airmobility is to achieve airmechanization, meaning the ability of helicopter-based combat units to conduct combined arms combat operations in the air and from the air both, either in conjunction with ground forces or as an independent force.

The process of fielding helicopters in the Army, which is determined by the resources available and the priorities to be given to partial tasks, needs to be adapted towards this guiding aim. This must be done in such a way that the capability of using the airspace near the ground in the functional areas of C³, reconnaissance, combat, combat support, and combat service support will be improved. As a result, there will be one airmechanized Army Aviation Brigade attached to the German Rapid Reaction Forces in addition to other Aviation formations within the coming new Army structure. This will be significantly changed from the current structure of one Aviation Brigade, consisting of all Army air transport assets above corps level and one anti-tank helicopter regiment at corps level.

New equipment. The Franco-German co-production Tiger is the latest generation of existing combat helicopters. It has been designed with a sufficient growth potential to be equipped for the anti-tank mission, escort role, and also for the

reconnaissance role. In view of the changing requirements, the German Army Aviation branch is planning to introduce the Tiger as a multi-role combat support helicopter to cover the entire mission spectrum of anti-tank defense, escort, and battlefield reconnaissance.

In order to improve its ability to dominate the battlefield, to penetrate enemy zones and to survive, mast-mounted observation and self-defense sensors are envisaged, as are active countermeasures against detection and incoming fire. The essential hardware and software portions of the Army Aviation C³I system, called HERGIS, will be developed as an element of the Tiger weapon system.

The Tiger weapon system also serves as a technology demonstrator for system components of aircraft that are still in early developmental throes, such as the Army LTH (NH-90) and the planned combat efficiency improvement of the CH-53G MTH. From the year 2005 onwards, it is intended to replace the "well-worn" UH-1D with the NH-90.

This modern transport helicopter will have a payload of two tons and will therefore be well-suited for the movement of troops and palletted supplies as well as accepting special mission equipment packages. Even in these times of low military budgets the continuity and the innovation of the German Army's helicopter planning is being maintained through the Tiger and NH-90 programs. These are complemented with the refurbishing and upgrading of older helicopters, including limited provision with sensors for low-level night flying.

In addition, emphasis must continue on associated equipment needed for helicopter operations in future operational zones that may differ significantly from Germany's terrain and climate conditions.

(GERMANY — contined on page 47)

THE ITALIAN ARMY AVIATION

The Italian Army Aviation was born in the U.S.A. In 1950, a small group of Italian officers was sent to Ft. Sill, OK to be qualified as fixed wing pilots. It was our "Class Before One", and the training was carried out on Piper L-18Cs. These officers symbolized the Italian Army's will to have its own air component; that is, an Army Aviation, not an Aviation for the Army.

On the 10th of May 1951, on a grassy strip of the artillery school 30 miles north of Rome, the first light aircraft unit was established. That was the act of birth of Army Aviation. Missions included: reconnaissance, local courier service, aerial photography, and, above all, artillery fire adjustment.

Organization. The Italian Army Aviation is the youngest Army specialty. It is set out to give the Armed Forces the "Airmobility" that is a vital and indispensable tool in modern combined arms tactics. At the central level, the Command and the Logistical organization includes the Army Aviation Directorate and his Command, subdivided into Army Avia-

*Italian
Army Aviation
has recently
deployed elements to
seven different
countries using
six different
aircraft types.*

tion Directorate and the Army Aviation Material Command.

The Army Aviation Directorate is directly subordinate to the Army General Staff and has the responsibility for employment and disciplinary issues of the Aviation Center. It is also the disciplinary authority for the 1st Army Aviation Regiment, an operational unit

assigned to the Army General Staff.

The Army Aviation Material Command is responsible for the following:

- Management of the Army Aviation Logistic Support and equipment
- Direct command of the Fourth Army Aviation Repair unit.

Other units, like this second level logistical support, are deployed to suitable locations inside the Italian territory to optimize and properly sustain the assigned operational units.

The Army Aviation Structure includes:

- Four Regiments, one under the direct Command of the Army General Staff, three Regiments organically subordinate to the Army Corps.

- Five Squadron Groups (Battalions) assigned to the Military District Commands.

- One Squadron Group assigned to the Parachutist Brigade.

Personnel. The composition of Army Aviation personnel is:

- 800 pilots, 50% officers and 40% NCOs;

- 1,500 technicians, 15% officers and 85% NCO flight engineers;

- 500 general service personnel, 20% officers and 80% NCOs-enlisted soldiers.

- 2,400 soldiers and civilian employees.

There are two kinds of officer pilots. One comes from the Military Academy, the other from the Military Schools. Officers maintain their Army specialty — infantry, artillery, cavalry, and so on. NCOs normally spend their entire career among Army Aviation units.

Activities. The average annual activity is more than 50,000 flying hours. They are divided among the following:

- 65% for operational purposes;

- 25% for training;

- 10% for the Civil Protection Department.

For the assistance and civil defence in emergency situations during peacetime, the tasks are assigned to the Military Forces by the Italian Constitution. With about 5,000 hours per year spent in these tasks, Army Aviation represents the main instrument of the Italian Army, capable of performing fire fighting interventions, mountain rescue, medical evacuation, and operations to help populations affected by floods or earthquakes.

The units are also employed abroad in peacekeeping missions, both under domestic responsibility or international organizations. We have a utility squadron — **ITALAIR** — with five AB-205 (UH-1) helicopters in the United Nations contingent (UNIFIL) operating in Lebanon,

which has been in place since 1979. As of January 1995, this unit has flown 19,648 hours. We also have a training mission in Morocco with five instructor pilots and one flying engineer.

Up to a few months ago, Army Aviation has also deployed with multinational forces with:

- an Attack Helicopter Squadron embarked on the air carrier *Garibaldi* with four A-129 Mangoose helicopters, protecting the withdrawal of the U.N. contingent from Somalia;

- A squadron in the former Yugoslavia, operating two AB-205s and one AB-206 (for reconnaissance), with a total of 1,087 flying hours;

- A squadron with the **PELLICANO** contingent in Albania, flying two multi-role AB-412s and two CH-47C Chinooks with 3,278 flying hours;

- a squadron operating in Somalia within the **IBIS** mission with six multi-role AB-205s, four CH-47C Chinooks, and three A-129 Mangoose attack helicopters, flying a total of 3,934 hours;

- a squadron within the Italian contingent **ALBATROS** in Mozambique, operating five AB-205s and three SM-1019 aeroplanes with 3,249 flying hours;

- a squadron in Namibia with the **UNTAG** Forces, operating eight AB-205s with a total of 2,835 flying hours, and;

- a squadron in Turkey with four CH-47Cs and four AB-205s with 600 flying hours.

If we consider the great difficulties related to the distance, the diversity of the fleet, the environmental conditions of some operation zones, and logistics and operational problems, we can easily realize the great effort that the Italian Army Aviation has sustained during this period.

Fleet. The fleet includes the following types of aircrafts and helicopters:

- Siai Marchetti 1019, a high perfor-

mance STOL, turbopropelled airplane, used in Command and Control, Observation, Liaison, and Reconnaissance roles;

- Dornier 228, a 19 passenger liaison twin-engined airplane, equipped with high-tech avionics;

- Agusta-Bell 206, a turboengined observation helicopter similar to the American TH-67 Creek;

- Agusta A-109 Hirundo (1 and 2 versions), a twin-engined exploration and escort helicopter, capable of forward observation and target acquisition missions;

- Agusta-Bell 205 (UH-1), a utility helicopter that is widely employed in tactical and logistic transportation;

- Agusta-Bell 212 and 412 Griffon are the natural evolution of the AB-205. These two-engined helicopters are equipped with high-tech avionic systems that allow full instrument flight capability;

- CH-47 Chinook is the heaviest cargo helicopter in service with Italian Army Aviation. It is essentially employed in tactical and logistic transportation;

- Agusta A-129 Mangoose, a twin-engine attack helicopter fit for anti-tank roles. It can operate in day, night, and adverse weather conditions. The basic armament includes eight TOW missiles and 14 rockets. The main functions of communication, navigation, fire, flight data management, and failure control are controlled by an Integrated Dual Computer System (IMS).

Agusta continues to deliver the original order of 60 A-129s. As of now, we have received 33. The second lot will have updated IMS, NVG compatibility, and auto-protections.

Future Prospects. Changes for Italian Army Aviation should include:

- The whole utility helicopter fleet replaced by the European NH-90.

- The latest Italian philosophy is focused on a single family of helicopters for the scout and attack missions. The founder will be the A-129 Mangoose. Advantages of this concept will be interchangeability of the main spare parts and components, better logistics, and easier supply.

- We look forward to developing the A-129 International. It embodies Augusta's modular attack helicopter concept. It is being designed to quickly convert in the

field, including equipment and weaponry, to serve the requirements of many missions, rather than be confined to one or two specific attack helicopter roles.

- A contract has been signed between Agusta and the Army to develop a retrofit of earlier A-129s, adding a gun turret and the capability for air-to-air missiles and NATO 70mm Mk-66 rockets.

- In the near future, we are going to face a complete reorganization of the Italian Army Aviation structure. The Directorate will be changed into the Army Aviation Command (AAC), with three regiments directly attached. One of these units will be an Attack Regiment with two attack battalions and one logistic support battalion. The Attack Battalion will have three squadrons for a total of 22 A-129s. It will be equipped with one A-109 Battalion Commander, two A-109 Scouts, and four A-129 Mangoses.

★ ★

LTC Garretto is the Italian Liaison Officer to the USAAVNC.

"The latest Italian philosophy is focused on a single family of helicopters for the scout and attack missions."

AUSTRALIAN ARMY AVIATION

North Australia is at once beautiful, yet hostile. In the tropical dry season, it is desert, razorback rock outcrops, incessant heat, dust and flies. In the wet, the desert turns green as expansive tracts of land are made impassible by standing water. The defence of the northern approaches to our vast continent presents the Australian Defence Force (ADF) with an Area of Operations which is unique in its dimension, terrain, and climate.

Over the past decade, changes imposed upon the world's defence forces have dominated their collective thinking, redirected their vision and influenced every aspect of operations. The Australian Army Aviation Corps (AA Avn) has embraced this era, doubling in size and significantly increasing its fleet and span of operations as it strives to gain acceptance as a full member of the combined arms team. The major catalyst for this growth was the acceptance by Army of the battlefield helicopter role from the Royal Australian Air Force (RAAF) in 1987 and the ensuing transfer of the S-70A-9 Black Hawk, UH-1H Iroquois

*In an era
of fiscal and
personnel reductions,
the Corps has
seen unprecedented
growth in its
fleet and personnel.*

and AS-350B Squirrel helicopters. It has continued with the introduction into service of the CH-47D, commencing in May 1995.

Australia's future security, like its economic prosperity, is linked inextricably to the security and prosperity of Asia and the Pacific. The United States will remain a major contributor to security in our

region, but it will neither seek nor accept primary responsibility for maintaining peace and stability.

Australia maintains the ability to adapt and expand its forces quickly enough to meet any development by other forces for major attack on our continent rather than maintaining the actual force structure for such operations. The current force structure is to be capable of dealing with "short-warning conflicts", the scale and intensity of which, may range from small scale raids to larger or protracted operations. As a result, the Australian Army is small by any standard, but particularly given its mission.

As at 30 Jun 94 the total personnel strength was 26,347 Regulars, 28,912

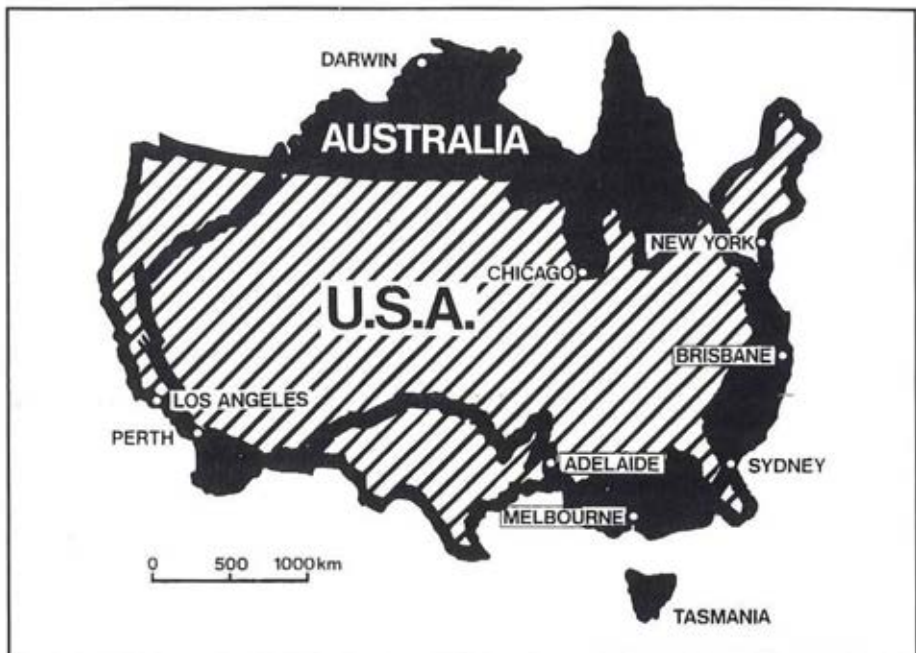

Reservists and 5,671 civilians. The Army is divided into three major commands, Land, Training and Logistics. Elements of Army Aviation are responsible to each of these commands. Land Command has only two divisions. The 1st Division is predominantly Regulars and has four Brigades. The 2nd Division is Reserves and has six Brigades.

Australia's Defence strategy is one of "depth-in-defence", derived from our ability to detect and engage hostile forces with a layered series of capabilities from distant surveillance and strike, through to maritime and air patrol and interdiction forces, to air defence and land forces on and over our own territory. To achieve this posture, the ADF needs to be able to undertake the following key roles:

- command, control and communications;
- intelligence collection and evaluation;
- surveillance of maritime areas and

northern Australia;

- maritime patrol and response;
- protection of shipping and off-shore territories and resources;
- air defence in maritime areas and northern approaches;
- defeat of incursions on Australian territory;
- protection of important civil and defence assets, including infrastructure and population centres; and
- strategic strike.

The capability, versatility and adaptability of Army Aviation make it critical to many of the above roles, many of which will be conducted jointly with other air and naval assets.

Personnel. The Corps has recently addressed a number of personnel issues. Our rapid expansion required additional aircrew. After considering the UK NCO and US WO aircrew schemes, it was

decided to introduce the Special Service Officer-Aviation (SSO). After three months of officer and 18 months of flying training, an SSO graduates as a Lieutenant. After five years the officer's performance is reviewed and, if acceptable, a further five years service may be offered. During this period, he or she could expect to be trained as a flight instructor and promoted to Captain. Further retention and promotion is offered on a case-by-case basis. To date, the SSO Scheme has been very successful with graduates demonstrating a high degree of professionalism in both their officer and aircrew duties.

Another marked change in personnel policy has seen the establishment of the Ground Crewman as the Corps' basic trade for soldiers. The Ground Crewman's duties include command post operator and all ground support tasks other than maintenance. After gaining experience, a soldier may progress through the ranks as either an Aircraft Handler, Aircrewman Loadmaster or Aircrewman Observer.

In the Australian Army, all equipment (including aircraft) maintenance is performed by the Corps of Royal Australian Electrical and Mechanical Engineers (RAEME). The introduction of the CH-47D has required the establishment of the Aircrewman Technical (equivalent to the U.S. Army's Flight Engineer).

The continued expansion of the Corps with the introduction of the CH-47D and the possibility of a two pilot crew and higher maintenance requirements for the envisioned new reconnaissance helicopter (see Procurement below) will continue to challenge the training system to meet the required manning levels.

Operations. AA Avn has two operational regiments, both under command of HQ 1st Division. 1st Aviation Regiment

is responsible for medium range surveillance and reconnaissance. 5th Aviation Regiment conducts airmobile operations and maintains a limited Aerial Fire Support capability. In addition to a demanding exercise program, recent AA Avn operations have included:

- Overseas deployments included a squadron of Black Hawks to support the UN mission in Cambodia and a squadron to support the establishment of a peace-keeping force on the island of Bougainville in Papua New Guinea (PNG) where separatists and the PNGDF have been in conflict for some years. In addition, AA Avn personnel have been deployed in Mogadishu in support of UNISOM II.

- The 1994 Christmas bushfires on the Australian east coast were well documented by the U.S. media. Aircraft from all three services and both Regiments were involved in all aspects of the disaster relief operation from command and control to personnel movement and firebombing.

- High DA and mountain flying training and operational support to the Army Malarial Research Unit and Royal Australian Engineer and Survey units in PNG.

- Training for low level operations (equivalent to OOTW) such as Services Protected Evacuations.

- The co-location of 5th Avn Regt with the Australian Army's Operational Deployment Force (ODF) and the need for both aircrew and user units to constantly practice airmobile operations have necessitated a high proportion of the regiment's flying hours be directed to ODF units.

- 5th Avn Regt Black Hawks have supported the AA Avn element of the national counter terrorist force.

In order to enhance the defence of northern Australia, the ADF is deploying force elements to the north. AA Avn has been involved with the deployment of

161 Reconnaissance Squadron (with a permanently attached troop of fixed wing aircraft to conduct wider area surveillance). 161 is also developing tactics, techniques and procedures for the conduct of air cavalry operations in northern Australia in conjunction with the 2nd Cavalry Regiment and the modified version of the USMC LAV 25 which is being acquired.

The current operational fleet consists of:

- 27 Black Hawks attached to the 5th Aviation Regiment;
- eight UH-1Hs modified to fill the gunship role attached to 1st Aviation Regiment;
- five UH-1Hs attached to the 5th Aviation Regiment;
- 19 Bell 206B-1 (Kiowas) attached to the 1st Aviation Regiment;
- and ten Nomad fixed wing aircraft attached to the 1st Aviation Regiment.

Training. The training of an Army pilot has changed significantly in recent times with the increase in number and complexity of the aircraft flown. The present training system is:

- Phase 1 — Basic Flying Training. This phase is conducted under civil contract at the Australian Air Academy. The 21 weeks provide 67.5 hours of fixed wing training and covers the basics of GF, IF, navigation and formation flight.
- Phase 2 — Development Flying Training. Conducted at the ADF Helicopter School (ADFHS), this phase is equivalent to the US IERW. One hundred and forty-seven hours are flown on the Eurocopter AS-350B Squirrel over six months.
- Phase 3 — Operational Flying Training (AQC) onto either the Kiowa, Iroquois or Black Hawk. The courses are conducted at the School of Army Aviation (SAA) over five months and 70 flying hours. Finally, the courses are integrated and conducted as a Regimental Officers' Basic

Course, in which all three types are exercised together under peacetime and operational scenarios.

Review of Pilot Training. In early 1994, Land Command expressed doubts that the Army pilot training system was able to train the numbers required and had no surge capacity. The Directorate of Aviation - Army undertook a study of the scheme. The final draft of that report, dated 26 August 1995, recommends the following sweeping changes:

- All Army pilot training should be placed under Training Command;
- Army pilot training should be treated as a continuum with a single terminal competency objective, not as separate courses with separate objectives;
- dispense with basic training on aeroplanes, instead training helicopter pilots on helicopters from the outset;
- consolidate all pilot training at the Army Aviation Centre under a single commander with a single focus;
- make the greatest practicable use of civil contracts for flying training and maintenance support, placing control with the training commander; and
- develop a formal simulation strategy as soon as practicable to maximise benefits from modern technologies in training.

AA Avn has traditionally trained its helicopter instructors in the U.S. and the UK but has long seen the need to conduct this training in Australia. The Instructor Training Wing at the ADFHS was raised and conducted its first course in 1992. Three courses were conducted in 1994, graduating ten instructors (including the first foreign student from PNG). A reduced number of instructors are now being trained overseas.

The past year has also seen AA Avn preparing for the introduction of the CH-47D. With the first aircraft due in May 1995, a training program was devel-

oped which has seen aircrew and maintenance personnel training in the US and UK. With an initial purchase of only four aircraft, all training, with the exception of the AQC is to be conducted within the operational squadron. The AQC for all pilots is to be conducted at the USAAVNC, Fort Rucker.

Simulation. Tenders are currently being evaluated for the procurement of an S-70A-9 Full Flight and Mission Simulator (FF&MS). The simulator is expected to be available for training in February 1998. A Training Requirement is being produced for a fixed base UH-1H Flight Training Device to supplement emergency procedure and IF training at the SAA. All three schools and the RAEME Aircraft Maintenance School are making increased use of computer based training.

It is possible that decreasing Black Hawk rates of effort will lead to a reduction in critical flying skills. This concern is being addressed with the conduct of simulator training in the U.S. The first such training was conducted by 16 pilots at the 25th Infantry Division in Hawaii in April 1995, and is expected to continue each six months until the introduction into service of the S-70A-9 FF&MS. Provision has also been made within the CH-47D Program for each pilot to conduct a period of 20 hours simulator training annually under the instruction of the squadron IP. The training will be conducted on the CH-47D Simulator at Fort Hood, TX approximately every six months commencing in April 1995.

Procurement. Within the ADF, the RAAF has single service responsibility for the procurement of Air Force and Army aircraft and associated equipments. The major upcoming procurements for Australian Army Aviation are:

CH-47D. The ADF's fleet of 11 CH-47Cs, purchased in 1973 and previ-

ously operated by the RAAF, was withdrawn from service in June 1989 due to its high operating costs and budgetary constraints and was placed in storage. Subsequent exercises and operations have demonstrated a clear requirement for medium lift helicopters. Seven of the aircraft were sold to the U.S. Army in exchange for the upgrading of four of the aircraft to the CH-47D configuration and a support package. The CH-47D is to be introduced into the Army as the Medium Lift Troop of the newly raised C Squadron, 5th Avn Regt, commencing in May 1995 with the delivery of the first two aircraft. The second pair are to arrive July 1995. The Troop is expected to be operational by January 1997.

Black Hawk Full Flight and Mission Simulator. Tenders are currently being evaluated for this project which seeks an FAA Level D device for S-70A-9 training and mission rehearsal. This is a demanding requirement as no Level D device has yet been developed. Selection of the preferred tenderer is expected by September 1995, with contract signature in February 1996 and an in-service date of February 1998.

Project Air 87. This project seeks to enhance the aerial surveillance, reconnaissance and fire support for the Australian land force. The three elements are:

- acquisition and fitment of a surveillance sensor suite to an in-service fixed wing aircraft;
- acquisition of new surveillance and reconnaissance helicopters fitted with integrated sensors, night pilotage system, self defence armament and an aircraft survivability equipment suite; and
- acquisition of new fire support helicopters, possibly with an element of commonality with either the AIR 87 reconnaissance helicopter, or another in-service (AUSTRALIA — continued on page 69)

WARSTEED '95: 2ND INFANTRY DIVISION STYLE

The 5-17th Cavalry Squadron (Minus) successfully deployed to the Republic of Korea in July 1994. Since this time, the air and ground troops spent several months preparing for our External Evaluation (EXEVAL), which was completed in January 1995.

With three ground (M1 tank/M3 CFV) and two air (OH-58D) troops, we are the most lethal battalion size fighting organization in the military. When the squadron transitioned from three AH-1 troops to two OH-58D Kiowa Warrior troops, we kept the critical mission of providing 24 hour reconnaissance and security operations across the 2nd Infantry Division's front. Initially, we had doubts if the squadron could maintain the same OPTEMPO with two air troops. As our training progressed, many of these doubts were put to rest. We realized we could maintain a high OPTEMPO by employing smaller air cavalry assets and a greater reliance on our ground cavalry troops.

We entered the 2nd ID's campaign season around September 1994 with an intensive squadron training program

Important considerations for around-the-clock Air Cavalry Planning.

geared toward building an integrated fighting organization. This campaign season is modeled after the National Training Center (NTC) environment. The 2nd ID evaluates each maneuver unit's ability to accomplish its Mission Essential Task List (METL) in a near real-world threat force-on-force environment.

The purpose of this article is to provide cavalry planners with useful information in preparing for and conducting continuous reconnaissance and security operations. Particular emphasis is placed on our EXEVAL lessons learned while outlining how our Kiowa Warrior assets helped accomplish the Division Commander's mission requirements.

January 1995 came upon us fast. We started the new year out as the first unit to go through the EXEVAL gauntlet. After several intense months of training, the campaign season was a period we all looked forward to completing. Several questions were evident at the start of and during our evaluation.

Battlefield Coverage. What size element do we use for each reconnaissance

Figure 1

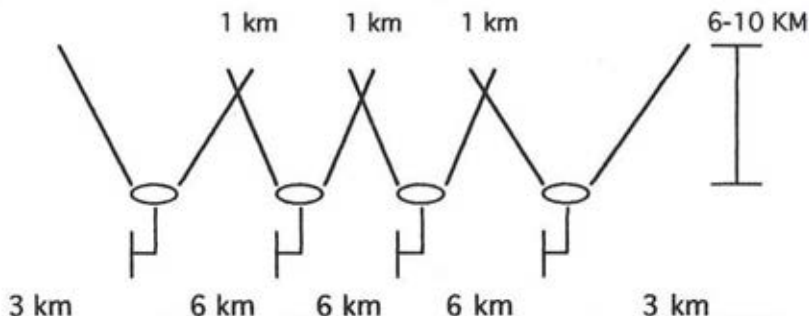

Depicted is a platoon on a stationary screen with maximum aviation assets forward.
This theory relies on a best case maintenance availability rate.

and security operation? For every mission, we used a troop planning factor of six out of eight aircraft mission capable. This proved to be a reliable number for us. We had to really consider the Division Commander's intent and air coverage duration requirements in deciding what size element to employ. To sustain continuous coverage, we employed Kiowa Warrior platoons (three to four aircraft) during each mission cycle.

How much terrain can a Kiowa Warrior platoon effectively cover during reconnaissance or security operations? Doctrinally, an air cavalry troop can cover a 15 kilometer front. An air cavalry platoon can cover roughly five to ten kilometers. What is not considered in this doctrine is the advanced sighting system found on the OH-58D's Mast Mounted Sight (MMS). The average maximum ranges OH-58D aircrews reported in Southwest Asia were ten kilometers for detection and six kilometers for recognition. Let's look at two possible planning theories.

The first theory (Figure 1) is based on Kiowa Warrior units operating in a flat or semi-flat desert environment. Four aircraft, with a one kilometer MMS line of sight overlap between, could cover a 24 kilometer front for a limited time.

The second theory (Figure 2) is based on Kiowa Warrior units operating in mountainous and extremely vegetated terrain. This is the planning theory we used during our EXEVAL and the type environment we operate in. The average maximum ranges we found were three to four kilometers for detection and recognition. If our aircraft had good MMS line-of-sight down a valley, our aircrews reported five to six kilometers for detection and four to five kilometers for recognition. Ranges are reduced due to Korea's daily environmental fog and haze.

Based on our excellent aircraft maintenance availability rate, the requirement to conduct continuous operations, and internal refuel rotations, no more than three to four aircraft were on station during any mission cycle. To cover a large front, our aircrews had to focus on terrain our ground troops could not cover, enemy high speed avenues of approach, or specific squadron or division Named Areas of Interest (NAIs).

Maneuvering our ground troops through the rugged Korean terrain proved extremely challenging at times. Our ground and air troops did an effective job of complementing each other during these challenging times. The air troops/platoons

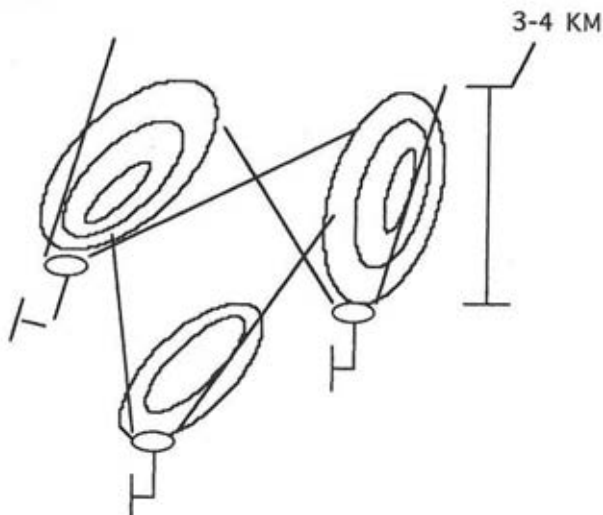

Depicted is a platoon covering a possible enemy avenue of approach in a defile.

concentrated on the high ground and used their MMS to scan down toward the low ground while the ground troops concentrated on the low ground and used their thermal sights to scan up toward the high ground. This has to be a coordinated effort between the ground troop commander and the Kiowa Warriors working the ground troop's zone or sector. During this process, it is important for the air and ground element to continuously talk with each other on the troop or squadron command net.

Fighter Management. Providing continuous operations raised other important planning questions. How do we keep our air cavalry troops within the limits of the squadron fighter management program? This question forced us to set strict day/night mission rotation cycles. One key lesson learned we used immediately was to involve the air troop commander in the mission planning process. It is very easy for cavalry planners to set arbitrary troop mission rotation cycles without

getting "green tab" input.

FM 17-95, *Cavalry Operations*, says that fatigue is probably the foremost degrader of performance. Performance and efficiency begin to deteriorate after 14 to 18 hours of continuous work and reach a low point after 22 to 24 hours. We knew that any deviation from our mission rotation cycles would result in performance decrements and possible loss of air cavalry presence due to fighter management (crew endurance).

We knew we might have to provide the division with 24 hour reconnaissance and security operations before our EXEVAL started, but we did not map this process out until late one EXEVAL night. We knew that 24 hour coverage would be extremely challenging. As we started mapping this process out, we had to quickly clarify an important question: What is the critical time the Division Commander wanted air coverage? Not to our surprise, the answer was 24 hours. To satisfy his requirement (well, almost)

<u>Platoon</u>	<u>Mission Cycle</u>	<u>Coverage</u>
D1 (1st Plt, D Trp)	0630-1300	6.5 Hours
D2	1230-1900	6.5 Hours
E1 (1st Plt, E Trp)	1830-2430	5.0 Hours*
E2	2400-0630	4.0 Hours**

* Aircrews were limited to six hours maximum flight time; two hours must be day flight time.

** Aircrews were limited to four hours maximum NVG flight time.

Note: A thirty minute overlap was factored in to allow platoon battle handover and egress times. During the 1830-0630 hour mission cycle, the air troop commanders need to know the critical time to operate to remain within the limits of their troop fighter management program.

Figure 3

Success Factors to Remember

1. Decide the size of the element you'll employ considering your higher commander's intent, critical air coverage time, and your operations area.
2. Based on your fighter management program, decide the air cavalry troop rotation cycles before starting any training exercise or battle drill.
3. Employ your Kiowa Warrior assets at night if possible. This capitalizes on the OH-58D's advanced night detection/targeting system.

we could provide a maximum of 21.5 hours of continuous coverage (Figure 3).

Day Versus Night Employment. Employing the OH-58D Kiowa Warrior during the day had a greater chance of being shot down by OPFOR versus employing this aircraft at night. Shooting this aircraft down at night was virtually impossible under blackout conditions. Under blackout conditions, our aircrews were finding the OPFOR before they were set in their defensive or offensive fighting positions. This really threw a "crimp" in the OPFOR plan.

Lessons to Build On. A Kiowa Warrior-equipped Divisional Cavalry Squadron faces many challenges on the digitized battlefield. One of the biggest challenges we faced was conducting continuous

reconnaissance and security operations.

Our Warsteed '95 brought out many important planning considerations for any cavalry organization to use. Most of these considerations are critical to the success of any operation. I'll leave you with one last question to think about: Have you really mapped out the planning considerations I've discussed in this article? If you haven't, don't wait until late one night when you find yourself in a similar situation faced with similar questions, as we were during our Warsteed '95 EXEVAL. "Out Front!"

★ ★

CPT Walach is the Operations Officer, 5-17th Cavalry, Republic of Korea.

ARMY AVIATION AND THE HELICOPTER V: THE H-21 SHAWNEE, PART II

Continued from the May 1995 issue of ARMY AVIATION

Prior to the production of turbine-engine helicopters, the H-21 was the aircraft most often used to set world helicopter records. In 1953, the Air Force used H-21s to set speed and altitude records — 146.7 miles per hour and 22,110 feet altitude.

Following the Army's acquisition of H-21s, the Army Aviation Board at Fort Rucker decided in 1956 to conduct a series of tests to determine the maximum practical helicopter range and non-stop time in the air. H-21s were used for these tests and set two new world records. In early August 1956, two Army aviators flying a Shawnee set a new range record of 1,199.7 miles for a helicopter in a closed course. Filled with fuel to 3,000 pounds over the normal maximum gross weight, the H-21 flew nonstop without refueling for 11.97 hours.

Another helicopter record established by the Army with an H-21 in 1956 was for total non-stop distance with refueling in flight. Tests were successfully conducted in July 1956 refueling helicopters from a U-1A Otter — not because the Otter was particularly appropriate, but because it

*How the
Piasecki
H-21 Shawnee
paved the way
for the
Boeing
CH-47 Chinook.*

was the largest fixed-wing aircraft in the Army inventory. The next logical step was to use the Shawnee in a cross country flight with refueling along the way to be accomplished by an Otter.

An H-21, named "Amblin' Annie" by its crew, made history in August 1956 as the first helicopter to fly coast-to-coast non-stop.

The helicopter, with a crew of two Army aviators and one Army civilian test pilot, left Miramar Naval Air Station near San Diego, CA, in the early morning and landed on the ground before the Pentagon 31 hours and almost 3,000 miles later.

The helicopter was refueled in flight from a U-1A Otter using a powered reel, a pump, and 207 feet of hose with nozzle attached. The aircraft normally cruised at 75 to 80 knots and slowed to 70 knots while refueling. Maintenance problems were practically nonexistent during the flight, and the test pilot declared that "Amblin' Annie was running better at the finish than at the start." Fuel consumption ranged from 60 to 95 gallons per hour, depending on the fuel load, and averaged

75 gallons per hour.

The flight of Amblin' Annie provided Army aviation and its helicopter program with a significant amount of publicity. Additionally, the flight demonstrated the feasibility of in-flight refueling of helicopters and the possibility of the self-deployment of entire helicopter battalions for considerable distances and in response to various contingencies.

Also during the summer of 1956, Army H-21s were used to fly more than 100 key government officials out of Washington, D.C., in a civil defense mass evacuation as part of Operation ALERT. Later that year, two H-21s, along with six H-19s and one H-34, were used at Fort Rucker in a demonstration of the ability of helicopters to replace Army trucks in moving men and materiel of an infantry battalion during training exercises.

The self-deployment capability of the H-21 demonstrated by Amblin' Annie was utilized in August 1958 by the 80th Transportation Company (Light Helicopter). The 80th, with 15 Shawnees, made the longest helicopter trip on record by deploying to Fort Richardson, AK, from Fort Riley, KS, a distance of 3,500 miles. The deployment required considerable planning to determine the best route and to ensure the availability of adequate high octane aviation gasoline and engine oil. Some 3,000 people met the H-21s as they arrived at their destination, resplendent in their red and white Alaska-service paint.

H-21s and Publicity for Army Aviation. In March 1958 an H-21 assigned to the 33rd Transportation Company, Fort Ord, CA, was outfitted with snowshoes made of plywood to conduct a rescue operation on the slope of Mount Lyell at approximately 12,000 feet altitude. Four skiers were stranded in an area where the snow was approximately 16 feet deep, and the snow-flotation device was deemed

to be necessary to prevent the Shawnee from sinking unevenly and tipping over. A couple of years later another H-21 conducted a rescue on the slope of Alaska's Mount McKinley. By this time, skis made of fiberglass and plastic and designed specifically for the H-21 had been produced and tested. The H-21 landed on Mount McKinley at over 10,000 feet, glided to a stop, effected the rescue and took off with no problems whatsoever.

Later in 1958, the Vertol Aircraft Corporation used H-21s to develop and demonstrate a helicopter multi-lift system, by which two or more helicopters could lift very heavy loads. The device consisted of an aluminum alloy spreader-frame with cables connecting the helicopters to the load. According to the president of Vertol, the spreader-frames would be much cheaper than the development and testing of a special purpose crane-type helicopter, which would have only limited mission capability.

During 1961, H-21s of the 65th Transportation Company (Light Helicopter), Fort Wainwright, Alaska, provided indispensable transportation services to the U.S. Army Engineer District, Alaska, in a feasibility study for the proposed Rampart Canyon hydroelectric project. Snow scooters and various other means of transportation had been tried between 1959, when the study began, and 1961, when the H-21s became available, but none had proven successful. According to the district engineer, the H-21 had good maneuverability and adequate capacity for carrying men and supplies.

During Exercise GREAT BEAR, a ten-day maneuver in Alaska in February 1962, three aviation companies using H-21s provided tactical troop transport and logistical support for two reinforced battle groups. This exercise clearly demonstrated the utility and effectiveness of

aerial logistics support of ground troops — especially in areas of impeded land transportation.

Armed H-21s. The H-21 was one of several helicopters used by the Directorate of Combat Developments at Fort Rucker in experiments with arming helicopters during the late 1950s. Shawnees, along with Choctaws, Chickasaws, and Sioux were included in the 26 helicopters assigned to the 8305th Aerial Combat Reconnaissance Company for these experiments.

According to COL Jay D. Vanderpool, his helicopter armament team at Fort Rucker searched the country looking for weapons to test on helicopters and tried whatever looked reasonably feasible. They rigged twelve 4.5 inch rocket tubes to the nose wheel strut of an H-21 and attached a B-29 gun turret under the forward fuselage of another. With the cooperation of the Vertol Corporation, the Aviation Center devised an experimental combined installation consisting of twin .50 caliber machine guns and four rockets that fitted on the nose gear of the H-21. Vanderpool's team also experimented with easily removable .30 caliber machine guns mounted in the cabin doors. The first successful firings of the H-21 armaments were conducted in February 1957. In 1961 the Army Aviation Board tested the 2.75 inch rocket using the H-21 helicopter.

H-21s in Algeria. During the first half of 1956, the Vertol Corporation delivered the first of 50 H-21s to the French government. Some of these aircraft were sent directly from the U.S. to Algeria. By 1 March 1957, 23 had arrived in Algeria and an additional ten in France. The French Air Force operated helicopters in western Algeria to transport army units, and the French army conducted its own organic helicopter operations in eastern

Algeria. The French Army used the H-21 as its principal helicopter in troop assault operations. The helicopter base was at Setif, and French Army troops were usually within ten minutes flying time from any potential trouble spot in eastern Algeria. Technical support of Army as well as Air Force helicopters was under the French air ministry.

The French army used helicopters principally against bands of guerrilla fighters in mountain areas. Helicopters were used for two major types of assault missions:

- immediate reprisal missions to engage guerrillas before they merged back into the population, and
- pre-planned missions — conducted in areas of extensive guerrilla activity.

The latter missions were carefully planned; helicopters delivered troops and supplies, aided in shifting troop concentrations, and evacuated wounded soldiers. Although the helicopter missions were thought by some French leaders to create more rebels than they captured or killed, the practice appeared effective to others, and it continued.

Shawnee helicopters usually landed in areas from 3,000' to 7,000' elevation and transported an average of 13 fully equipped combat troops per mission plus a crew of two or three. The crew chief usually stayed at the staging area to service helicopters between missions except when wounded were being evacuated or when a hoist or sling was being used.

The French discovered that suppressive fire from the helicopter was the most effective form of protection from ground fire and began installing weapons similar to those experimented with at Fort Rucker. By 1959 they had armed H-21s with both rockets and .30 caliber machine guns, but the major problem encountered by the French in arming H-21s was lack

of power — an inherent problem of reciprocating-engine helicopters. The armed H-21s could barely get off the ground — even without troops. The French then began arming the French-made turbine-powered Alouette helicopter to fly escort for the H-21s. The Alouette is purported to have been the first helicopter to be armed and used effectively against insurgents. The French in Algeria, using the H-21 and then the H-21 in conjunction with the Alouette as an armed escort, made significant progress in the development of air assault tactics and doctrine — lessons that were later applied by the Americans in Vietnam.

Several other nations in addition to Canada and France acquired H-21s for military uses. West Germany obtained 52 for troop transport and logistic resupply in 1957 and 1958; Burma acquired six from the U.S. Air Force in 1958; and Sweden acquired six from the U.S. Air Force in 1959. Also, in 1960, the Soviet Union received one of the two H-21s that it had ordered — ostensibly to be used as an executive transport.

Expanding Role of the Transportation Corps. The Army continued to rely on the Air Force to negotiate the procurement of Army aircraft and to provide technical support in major engineering problems throughout the 1950s. By 1957, however, the logistical support of Army aviation had become one of the major missions of the Army Transportation Corps. A memorandum of agreement of September 1954, transferred storage, issue, and depot maintenance of Army air items from the Air Force to the Army. This agreement was implemented gradually from 1955 to 1957.

By 1957, the Transportation Supply and Maintenance Command of the Transportation Corps processed most requisitions for aviation parts and was also responsible for

depot maintenance of Army aircraft. The Transportation Corps was additionally involved with aircraft improvement, for which purpose it established the Transportation Aircraft Test Support Activity at Fort Rucker. To paraphrase its chief, the Transportation Corps aimed at removing from the commander's mind the worry about maintenance and supply support of his aircraft.

During this same time period, however, the Transportation Corps' domination of Army aviation was being challenged by various developments. For one thing, the possibility of an aviation branch was being seriously considered by the Army. Secondly, a gradual shift was occurring in the Army doctrine and practice regarding the use of Army helicopters. While they had been used mostly for combat service support up to that time, the tactical use of Army aircraft was becoming a matter of increasing interest and concern to many Army leaders. In July 1954, for example, GEN James Gavin wrote the chief of Army Field Forces that the function of logistical support by helicopters should be relegated to secondary importance, and that the combat arms should develop the application of airlift by helicopter to meet their doctrine and techniques. Also, as described in the first part of this article in the May issue, the Army combat arms were becoming increasingly interested in the use of helicopters for sky cavalry and air assault operations. For what Army aviation was in the process of becoming, the almost total control of Army aircraft by an Army technical service did not seem to be any more appropriate than Air Force control.

Development of the Turbine Engine. During the late 1950s, the H-21 was used to help prepare the way for its own demise. The Vertol Corporation began experimenting with the substitution of two

turbine engines for the single reciprocating engine in the H-21 during the first half of 1956. The Army announced plans later in 1956 to replace its piston-powered cargo helicopters with turbine-powered aircraft. Bell Aircraft Corporation delivered a test batch of six turbine-powered YH-40s to the Army and Air Force in August 1958.

The YH-40 was the test version of the HU-1A Iroquois (Huey) helicopter, the first turbine-powered helicopter to be designed specifically for the Army. Early in 1959, following extensive testing by the U.S. Army Transportation Test and Support Activity at Fort Rucker, a \$23,000,000 contract was awarded to Bell Aircraft for 110 HU-1As. Also by 1959, the Army had begun negotiating with Vertol to develop a new two to three-ton-capacity, turbine-powered transport helicopter — to be known as the Chinook. These two new turbine-powered aircraft would eventually replace not only the H-21, but also the H-34 and H-37 piston-engine helicopters. These piston-engine aircraft would serve the Army for a full decade, however, before being totally phased out.

The Vietnamese Conflict. On 6 November 1961, the 57th Transportation Company (Light Helicopter) with its twenty H-21s departed Gray Army Airfield, Fort Lewis, WA, for Stockton, CA. The helicopters of the 57th, along with those of the 8th Transportation Company (Light Helicopter), from Fort Bragg, NC, were loaded on the flight deck of the USS *Core*, which departed on 21 November with "destination unknown". Three weeks later, the *Core* arrived in Saigon; the first U.S. Army cargo helicopters had arrived in Vietnam. A training exercise involving H-21s from both companies and several hundred Vietnamese paratroopers was conducted north of Saigon on 22 and 23

December. The first H-21 mission into the combat zone occurred on 2 January 1962, when 1,036 ARVN troops were delivered into an otherwise inaccessible landing zone in the jungle. America's "Helicopter War" had begun.

Initially, the principal mission of Army aviation in South Vietnam was to train ARVN units and to provide the ARVN with mobility, communications, and control superior to that of the Viet Cong. During the first year, thousands of Vietnamese soldiers were trained for heliborne operations; the 57th Transportation alone trained 26,000 men during a three-month period, while also conducting around 20 assault missions. Upon being trained, these soldiers could board the H-21 in 18 seconds and off-load in 12 seconds. In order to be able to transport more Vietnamese troops and to facilitate loading and unloading, seats, cabin heaters, doors, and other equipment were removed from the H-21s.

A U.S. Marine Corps H-34 helicopter squadron arrived in Vietnam in early 1962, and another Army transportation company equipped with H-21s, the 93rd, arrived shortly afterwards. In mid-April 1962, Army and Marine transportation units conducted a successful joint air assault mission involving 1,100 ARVN troops.

On 1 April 1963, the 57th Transportation Helicopter Company became the first H-21 company to complete 10,000 flying hours in Vietnam. The 8th and 57th were redesignated the 117th and the 120th Aviation Companies (Airmobile Light) in June 1963. Later, after the H-21s had been phased out of service in Vietnam, these companies were incorporated into the 1st Aviation Brigade at its formation in 1966 as its oldest active units.

It was soon realized that the transportation helicopters in Vietnam required

effective protection from small arms fire. While fixed wing aircraft could strike the landing zones in advance of the helicopters and provide a degree of escort protection, the slow-flying H-21 was still a vulnerable target for a guerilla who stayed in his hole until the escort plane had come and gone. Machine guns were mounted in the doors and on the nose of the Shawnee to counter this threat, but this was not generally satisfactory. The H-21 was not versatile, fast, or maneuverable enough to provide effective firepower, even when armed with rockets and machine guns.

Before the end of 1962 armed helicopter units were assigned the mission of escorting H-21s in Vietnam. The first of these units, the Utility Tactical Transport Helicopter Company, was provided with UH-1A (HU-1A until 1962) helicopters armed with XM-2 machine guns. Other cargo helicopter units were subsequently organized with one or more platoons of armed helicopters. In late 1962, UH-1Bs, armed with XM-6 quad machine guns and 2.75 inch aerial rockets, began replacing the UH-1As.

The largest helicopter airlift of the Vietnamese conflict up to that time was conducted in December 1963. The 145th Aviation Battalion airlifted 1,280 Vietnamese marines and a brigade forward command post into two landing zones in the jungle near the Cambodian border. The Vietnamese marines were transported by the 120th Aviation Company using 13 H-21 helicopters. Other aviation companies provided UH-1B escorts for the airlift. Using the H-21, U.S. Army Aviation was, for the first time, conducting air assault missions in combat, albeit with Vietnamese troops. This mission had been denied the Army during the Korean conflict, although the Marine Corps developed techniques and tactics and successfully conducted air assault missions with

H-19 helicopters on a limited scale. The French used H-21s in Algeria to conduct air assault missions on a wider scale and for a more extended period.

The success of the air assault missions of H-21s during the early years of the Vietnamese conflict was undoubtedly an important factor in promoting the acceptance of the air mobility concept in the highest ranks of the Army and in the decision to convene the Howze Board and then instigate the 11th Air Assault Division test program. During the latter part of 1963, for example, GEN Earle G. Wheeler, Chief of Staff of the Army, gave unqualified support to the air mobility concept, which he said had become necessary for the Army to perform its mission of prompt and sustained combat on land. Air mobility, he observed, consisted of the use of aircraft for command and control, observation, reconnaissance, target acquisition, battlefield logistic support, and "the use of organic helicopters as troop carriers on the battlefield ... accompanied by the kind of organic fire reconnaissance elements and support which are always an integral part of maneuver units in all armies."

The Final Years. By the end of 1963, the Army had three turbine-engine helicopters in its inventory — the UH-1, the CH-47 Chinook, and the OH-6 Cayuse. The H-21 and the other reciprocating-engine cargo helicopters were being kept on until UH-1s and CH-47s were acquired in sufficient quantities to replace them. The Shawnee, however, had shown signs of fatigue for several years.

During the early 60s, for example, it experienced a higher rate of engine failure than any other Army aircraft. For this reason, "chip detector" warning lights (activated by high concentration of metal chips in the engine oil) were installed in all H-21s during 1961. Even with these

fairly effective early warnings of impending engine failure, however, the H-21 had almost three times more engine failures per 100,000 flying hours than any other Army aircraft and an average blade life of only about 300 hours.

Late in 1964, approximately three years after arriving in Saigon, the last of the H-21s was retired from service in Vietnam and prepared for shipment home. The last H-21 pilot class graduated at Fort Rucker in July 1964, and the last H-21 maintenance class graduated in July 1967. While being replaced in its various missions by the UH-1 and the CH-47, the H-21 remained in the Army inventory and continued to perform well for five years after being retired from Vietnam.

During its last few years, the Shawnee's role was tempered by its age, and publicity about it declined notably. There nevertheless continued to be occasional accounts of heroic rescues and other feats. In August 1966, for example, H-21s assigned to the U.S. Army Alaska's 19th Aviation Battalion were used to provide transportation and support, under very difficult conditions, for a geological study conducted by visiting NASA personnel in Alaska. The following year an Army H-21 landed on a jagged coral reef near Okinawa to rescue ten survivors of a Japanese fishing boat crew.

The Shawnee was finally removed from the Army inventory in August 1969. In the words of one Army aviator: "So call her a two-headed monster if you will, or a gas guzzling Hog, but ne'er forget, ole CH-21 faced her moment of truth, tasted the sweet fruit of success, and paved the way for the future."

★ ★

Dr. Kitchens is the Aviation Branch Historian, U.S. Army Aviation Center, Ft. Rucker, AL.

GERMANY

(Continued from Page 28)

Interoperability aspects. Interoperability is a great issue with the European Army Aviation community. There is no doubt that the maximum efficiency of airmobile and/or air mechanized formations is obtained if operations are combined with other major mechanized formations to make full use of their inherent flexibility and agility.

This requires the cooperation of future multinational formations and unrestricted interoperability with all of our allied forces. It is essential that everything from the single helicopter to the major formation can work together without complications. This requires at least a compatibility of the communication equipment, mostly radios, and corresponding interfaces/links for the various command and control systems. Therefore, interoperability must be a consideration in the early stages of equipment development. This is important not only for C³I systems but for maintenance support, ammunition, and other supplies as well.

Step by step, the European helicopter family is growing up. The Tiger and NH-90 are the forerunners of this development. This industry cooperation is attainable, considering the success of the Airbus Industry; however, much can still be accomplished.

AAAA provides an excellent example of military and industry working a common goal. A similar association in Europe could provide the added benefit of strengthening the Alliance and enhancing interoperability.

★ ★

LTC Winter is the German Liaison Officer to the USAAVNC.

The 1995 Aviation Officer Directory*

Sample

LAST NAME, First Name, M.I., (Rank) (Initial Membership Year) (Nickname) Residence Address. Dy: Duty Phone. Res: Residence Phone. S: Spouse's Name. Dy: Duty Assignment. Rtg: Pilot Rating. Qual: Qualification. Time: Total Hours Flight Time. Cbt: Total Hours Combat Time. DFC: Distinguished Flying Cross. AM/00: Number of Air Medals.

Pilot Ratings

MAA: Master Army Aviator

SAA: Senior Army Aviator

AA: Army Aviator

IFE: Instrument Flight Examiner

IP: Instructor Pilot

TP: Test Pilot

* A list of all AAAA Company Grade Officers who returned their response forms to the National Office by 24 April 1995.

Adams, James E., (CPT) (M89) (Jim) CMR 454, Box 3460, APO AE 09250. S: Devany, Dy: Company Commander. A Co. 3-1 Avn, Katterbach, Germany. Rtg: AA. RW Qual. Time: 750 Hrs./Cbt 40 AM/2. Vp, Programs, Wings Of The Marine Chapter.

Adams, Jay R., (1LT) (M92) 2414 Graham Road, Fayetteville, NC 28304. Res: (919) 487-9735. S: Teresa. Dy: D Co, 1/159th Avn, Fort Bragg, NC. RW Qual. Time: 420 Hrs.

Adelman, Alex J., (1LT) (M94) 9205 Pembroke-Oakgrove Rd, Oak Grove, KY 42262. Dy: (502) 798-4738. Res: (502) 439-0307. Dy: B Co, 6-101st RW Qual. Time: 320 Hrs.

Agens, Bryan F., (CPT) (M90) 102 Blackhawk Drive, Daleville, AL 36322. Dy: (334) 255-3344. Res: (334) 503-5060. Dy: 18th Avn, 229th Avn Regt, Fort Bragg, NC. Rtg: AA. RW Qual. Time: 620 Hrs.

Aiken, Coren J., (2LT) (M95) 400 Victoria Drive, Enterprise, AL 36330. Dy: (334) 255-9090. Res: (334) 393-2912. Dy: D Co, 1/145th.

Aiken, Jeffrey C., (CPT) (M93) (Jeff) 110 Lindsey Street, Enterprise, AL 36330. Dy: (334) 255-3344. Res: (334) 447-7588. S: Catherine. Dy: Officer Advanced Course, A-1-145th Avn, Fort Rucker, AL. RW Qual. Time: 535 Hrs.

Alley, David W., (1LT) (M90) (Gadget) 1325 Buttenwood Circle, Fayetteville, NC 28314. Dy: (910) 396-7478. Res: (910) 868-8278. Dy: 18th Avn Bde. Rtg: AA. RW Qual. Time: 770 Hrs.

Allmandinger, Joel N., (2LT) (M94) 2260 Westchester Drive, Apt. 7, Manhattan, KS 66502. Dy: (913) 239-3462. Res: (913) 539-3170. S: Kate. Dy: Scout Platoon Leader, 1st Infantry Div, Fort Riley, KS. RW Qual. Time: 200 Hrs.

Almeida, Pedro G., (CPT) (M89) 1051 Wateria Avenue, Apt. 11, Barstow, CA 92311-4981. Dy: (619) 380-4420. Res: (619) 252-1832. Dy: Aviation Observer/Controller, A Co. Opns Group, NTC Fort Irwin, CA. Rtg: AA. RW Qual. Time: 900 Hrs. AM/1. 88 AAAA Rotc Cadet.

Alpete, Scott R., (CPT) (M89) 522 Glenna Street, Fayetteville, NC 28311. Dy: (334) 255-1687. Res: (910) 630-4278. S: Diane. Dy: Company Commander, 3-229th Attack Helicopter Battalion, Rtg: AA. RW Qual. Time: 750 Hrs./Cbt 50 AM/3.1V.

Allien, Jayson A., (CPT) (M90) (Smokely) 5655 Lee Lane, Fincastle, VA 24060. S: Shelle. Dy: Fort Kobbe, Panama, Rtg: AA. RW Qual. FW Qual. Time: 760 Hrs. Life Member.

Anderson, Mark W., (CPT) (M90) HHC, 11th

Avn Regt, CMR 416, Box 1075, APO AE 09140. S: Mira. Dy: Asst S-3 Opns, Illerthorn, Germany. Rtg: AA. RW Qual. FW Qual. Time: 950 Hrs.

Anderson, Randall G., (CPT) (M89) 203 Gentry Avenue, Alexandria, VA 22305-1816. Dy: (703) 782-1104. Dy: Aide-de-camp, Walter Reed Army Medical Center, Rtg: AA. RW Qual. FW Qual. Time: 1,004 Hrs./Cbt 48 AM/2.

Anderson, Richard C., (1LT) (M92) (Rich) 3720-BMcCormack Road, Wahiawa, HI 96796. Dy: (808) 656-3450. Res: (808) 624-4264. S: Faith. Dy: Avn Plt Ldr, B Co, 4-25th Avn Regt. RW Qual. Time: 500 Hrs.

Andre, Richard M., (1LT) (M92) (Mike) 103 Hancock Street, Hinesville, GA 31313-2957. Dy: (912) 767-4861. Res: (912) 369-7374. S: Amy. Dy: Flight Operations Officer, 2-4 Cav. Rtg: AA. RW Qual. Time: 600 Hrs.

Andrews, Cort W., (2LT) (M93) 436 Tartan Court, Fayetteville, NC 28311-1668. Dy: (910) 396-1704. Res: (910) 482-0581. S: Tosie. Dy: Aik Plt Ldr, B Co, 1/229th AARH, Fort Bragg, NC. RW Qual. Time: 240 Hrs.

Angulo, Wenceslao, (2LT) (M94) (Wency) HHC, 2-2 Avn Regt, Unit 15427, Box 64, APO AP 96257. Dy: HHC, 2-2 Avn Regt. RW Qual. Time: 300 Hrs.

Aoki, Joel R., (1LT) (M94) (Seirfle) A Co, 2/501st Avn, Unit 15210, APO AP 96271-0146. Dy: Pilot-in-Command, Camp Humphreys, Korea. Rtg: AA. RW Qual. Time: 250 Hrs. AM/1.

Arbanas, Kevin A., (CPT) (M87) 1102 Walnut Court, Hopkinsville, KY 42240-5154. Dy: (502) 798-2923. Res: (502) 885-7537. S: Kilee. Dy: 7-101 Avn Bn, Fort Campbell, KY. Rtg: AA. RW Qual. Time: 1,000 Hrs./Cbt 84 AM/1.

Arterburn, David R., (CPT) (M85) (Arty) 4142 Lancaster Avenue, New Windsor, NY 12553. Dy: (914) 938-2956. Res: (914) 567-0720. S: Katy. Dy: Student, Naval Test Pilot School, NAS Patuxent River, MD. Rtg: AA. TP. RW Qual. FW Qual. Time: 1,100 Hrs.

Artman, Spencer Q., (CPT) (M91) (Spence) 4065 Daisy Mine Court, No. A, Fort Irwin, CA 92310-2008. Dy: (619) 386-4415. Res: (619) 386-7816. S: Traci. Dy: Air Cavalry Troop Trainer, Eagle Team, NTC Training Ctr. Rtg: SAA. RW Qual. Time: 1,750 Hrs.

Ault, Robert T., (CPT) (M93) 306 N. Swidler Street, Orange, CA 92669-2827. Res: (714) 288-0300. S: Kristi. Dy: Airfield Commander, Camp Page, Korea. Rtg: AA. RW Qual. FW Qual. Time: 1,500 Hrs.

Avila, Michael A., (CPT) (M91) (Mike) 5179-B

Crackerjack Lane, Fort Irwin, CA 92310. Dy: (619) 380-4949. Res: (619) 386-7804. S: Ann. Dy: Ft Opns Officer, 247th Mod Det, Fort Irwin, CA. RW Qual. Time: 1,100 Hrs./Cbt 68 AM/2.

BBBBBBBBBB

Baer, Robert A., (CPT) (M87) (Bob) 739 Oak Knoll, Leesville, LA 71446-8811. Dy: (318) 531-0216. Res: (318) 531-4087. S: Jane. Dy: JRTC, Avn Div, Fort Polk, LA. Rtg: SAA. RW Qual. Time: 1,000 Hrs.

Bahoque, Benjamin S., (2LT) (M94) (Ben) B Co, 1-501st Avn, Unit 15211, APO AP 96271-0142. S: Teresa. Dy: Maintenance Platoon Leader, Rtg: MTP. RW Qual. Time: 350 Hrs.

Bailey, George D., (1LT(P)) (M91) (Daniel) P.O. Box 140, Fort Campbell, KY 42223. Dy: (502) 798-2744. Res: (615) 551-3332. Dy: Apache Plt Ldr, A Co, 1-101st Avn. RW Qual. Time: 600 Hrs.

Baka, Michael A., (CPT) (M92) 1996 Timberline Way, Clarksville, TN 37042. Dy: (502) 798-5717. Res: (615) 648-8902. S: Seung Min. Dy: Battalion Adjutant, 7th Battalion, 101st Avn Regt, Fort Campbell, KY. RW Qual. Time: 700 Hrs.

Baker, Christopher, (CPT) (M89) (Chris) B Co, 2-2 Avn Regt, Unit 15427, APO AP 96257-0462. S: Hyun. Dy: Co Cdr, Camp Starley, Korea. RW Qual. Time: 1,300 Hrs. Past Chapter Officer.

Baker, Gregory A., (CPT) (M93) (Greg) 117 Palisades Drive, Enterprise, AL 36330. Dy: (334) 558-3344. Res: (334) 393-1795. S: Joan. Dy: A Co, 1/145th Avn Bn.

Banks, Bernard B., (CPT) (M92) (Bernie) HQ, Office of the CG, USASAC, 5001 Eisenhower, Alexandria, VA 22333-0001. Dy: (703) 274-8380. Dy: Aide de Camp, CG US Army Security Assistance Cmd, Alexandria, VA. Rtg: AA. RW Qual. Time: 550 Hrs.

Banning, Keith K., (CPT) (M94) 327 Southland Drive, Fayetteville, NC 28311. Res: (910) 488-2788. S: Pam. Dy: Asst S3, 82nd Avn Bde. Rtg: IP. RW Qual. Time: 2,100 Hrs.

Barksdale, James A., (CPT) (M91) (Bo) 43 Stratton, Tupelo, MS 38801. Dy: (601) 680-8305. Res: (601) 566-2614. S: Renee. Dy: Admin. Officer, MS ARNG.

Bamby, Stuart L., (CPT) (M88) (Stu) C Co, 2-1 Avn Regt, CMR 454, Box 2133, APO AE 09250-5000. S: Beth. Dy: Cdr. Rtg: MTP. RW Qual. Time: 920 Hrs. Life Member.

Barnes, Daniel T., (CPT) (M95) 100 Davis, No. 45, Enterprise, AL 36330. Dy: (334) 393-9647. Res: (334) 393-9647. Dy: A Co, 1/145th Avn Regt. RW Qual. Time: 300 Hrs.

Barnes, James R., (CPT) (M89) (Bob) CMR 416, Box 525, B Troop, 6-6 Cav, APO AE 09140. S: Kris. Dy: Pilot, Troop Commander, Weisheim, Germany.

Barr, Glenn J., (CPT) (M86) 8634 Belloc Circle, Colorado Springs, CO 80920. Dy: (719) 525-3580. Res: (719) 262-1453. S: Janet. Dy: DMHC, DISCOM, 4 ID (M), Fort Carson, CO. Rtg: AA. RW Qual. Time: 730 Hrs.

Bartee, Shano E., (CPT) (M91) Talon Chap Treasurer, 2-6 Cav., CMR 410, Box 99, APO AE 09140. S: Susanna. Dy: Adjutant, RW Qual. Time: 500 Hrs. Treasurer, Talon Chapter.

Bartley, Jennifer A., (2LT) (M94) 380 Tar Hill Road, Apt. 7, Daleville, AL 36322. Dy: (334) 255-3311. Res: (334) 598-1358. S: Milton. Dy: Student. Rtg: AA. RW Qual. Time: 180 Hrs.

Bassett, Esther C., (2LT) (M94) (Cind) Route 3, Box 275B, Enterprise, AL 36330. Dy: (334) 255-3311. Res: (334) 393-1914. Dy: A Co, 2/158th Avn, Fort Sil, OK. RW Qual. Time: 200 Hrs.

Basham, Timothy A., (CPT) (M91) 3320 Johnson Street, Killeen, TX 76542. Dy: (817) 287-1250. Res: (817) 229-9871. S: Michelle. Dy: Commander, D Troop, 2-1 Cavalry (2AD), Fort Hood, TX. Rtg: AA. RW Qual. Time: 600 Hrs.

Bassett, David E., (CPT) (M89) A Co, 3D MI Bn(AE), Unit 15220, Box 714, APO AP 96271-0156. S: Robin Ann. Dy: Commander, Camp Humphreys, Korea. Rtg: SAA MTP. RW Qual. FW Qual. Time: 1,725 Hrs.

Bastian, Jerold D., (CPT) (M93) (Jerry) 140 S. Ethel Lane, Lansing, KS 66043. Dy: (913) 684-8422. Res: (913) 727-2840. S: Kelley. Dy: NSC, Fort Leavenworth, KS. RW Qual. FW Qual. Time: 1,400 Hrs.

Baumberger, Robert S., (CPT) (M89) (Rob) 3190 Pecan Cove Drive, Coppertown Cove, TX 70522-3708. Dy: (817) 287-4694. Res: (817) 547-6741. Dy: Brigade S1, Aviation Bde, 2nd Armored Division, Fort Hood, TX. Rtg: SAA. RW Qual. Time: 1,100 Hrs./Cbt 52 AM1/V.

Bay, Dennis J., (CPT) (M94) 5075 Victory Road, Colorado Springs, CO 80911. Dy: (719) 526-3325. Res: (719) 592-3477. S: Kristen. Dy: 44 Bn S-4. RW Qual. Time: 500 Hrs.

Beatty, John D., (CPT) (M89) 25 Parkside Drive, Richmond Hill, GA 31324. Dy: (912) 352-5821. Res: (912) 756-4133. S: Sharon. Dy: A Co, 224th MI Bn(AE), Hunter AAF, GA. Rtg: AA. RW Qual. FW Qual. Time: 1,300 Hrs.

Beaudoin, Christopher, (CPT) (M87) (Chris) 515-2 Rimrock Terrace, Fort Riley, KS 66442-1124. Dy: (913) 239-6906. Res: (913) 784-2738. S: Laurie. Dy: S-3 Air, 4th Bde, 11D (M). Rtg: AA. RW Qual. Time: 925 Hrs./Cbt 45 AM2.

Beckinger, Richard M., (CPT)(P) (M89) 40 Westwood Estates, Sattilo, MS 38966. Dy: (601) 680-8330. Res: (601) 809-1520. S: Suzanne. Dy: Resident Training Detachment Chief, 1/185th CMD Avn. Bn. RW Qual. Time: 1,750 Hrs. AM1.

Behm, Darren W., (CPT) (M94) Route 3, Box 279-B, Enterprise, AL 36330. Dy: (334) 255-5064. Res: (334) 393-1843. Dy: Commander, HHD, 1-14th Avn Regt. Rtg: IP. RW Qual. Time: 1,000 Hrs./Cbt 20 AM/3.

Belin, George S., (CPT) (M89) 39 Cutler Drive, Savannah, GA 31419. Dy: (912) 353-2668. Res: (912) 925-8290. S: Molly. Dy: Commander, B Co, 4-24th Avn Regt, 24th Combat Avn Bde. Rtg: AA. RW Qual. Time: 700 Hrs.

Belobrajdic, Paul G., (CPT) (M94) (B11) 37 Tara Trailer Park, Fort Rucker, AL 36362-2501.

Dy: (334) 255-3718. Res: (334) 598-9426. S: Barbara. Dy: Executive Officer, F/214 Avn Regt (AVM). Rtg: MTP. RW Qual. Time: 2,100 Hrs./Cbt 60.

Beltran, Salvador, (CPT) (M91) (Sal) 4317 Wofford Drive, No. 3, Fort Riley, KS 66422-1832. Dy: (913) 239-3143. Res: (913) 784-3591. S: Mabe. Dy: Platoon Leader, AH-64 Attack, B Co, 1-1 Aviation Rgt. AA. RW Qual.

Benson, Kelly A., (1LT) (M91) 233-3 Waterdown Drive, Fayetteville, NC 28314. Dy: (910) 390-9230. Res: (910) 864-2551. S: Ronald. Dy: Fwp Platoon Leader, 1-159th Avn.

Benter, George W., (CPT) (M89) 3706-B Collier Street, Wahiawa, HI 96786. Dy: (808) 655-2435. Res: (808) 624-8277. S: Kaoru. Dy: HHD 524th CSSB Schofield. Rtg: AA. RW Qual. Time: 800 Hrs.

Benzing, Andrew E., (2LT) (M95) (Andrew) CMR 2, Box 12695, Fort Rucker, AL 36362. Res: (334) 598-1647. Dy: D Co, 1-145th Avn Regt.

Bequette, Bryan W., (CPT)(P) (M88) (Bryan) HHC, 4th Bde, Unit 20194, Box 35, APO AE 09165. S: Kelly. Dy: 9-22th ASB, S-3, Hanau, Germany. Rtg: SAA. RW Qual. Time: 1,300 Hrs./Cbt 65 AM/1.

Bheodant, Balram J., (CPT) (M91) (B) P Co, Box 399, John, CA 93928. S: Satya. Dy: Test & Experimentation Command, Fort Hunter Liggett, CA. RW Qual. Time: 1,670 Hrs.

Bianchi, Joseph S., (CPT) (M90) (Joe) Mid-America Chap Treas., 424 B Lowe Court, HHC, KS 66442. Dy: (913) 239-6755. Res: (913) 784-3782. S: Neysa. Dy: Adjutant, 1-1 Avn. Rgt. RW Qual. Time: 600 Hrs. Treasurer, Mid-America Chapter.

Bingham, David D., (CPT) (M91) 3611 Levy, Killeen, TX 76547-1824. S: Crystal. Dy: Asst S4, Avn Bde, 1st Cav Div, Fort Hood, TX.

Bishop, Eric T., (CPT) (M89) 12 Gorman Avenue, Indiana, PA 15701. S: Lori. Rtg: SAA. RW Qual. FW Qual. Time: 1,350 Hrs.

Black, Ronald C., (2LT) (M94) (Chris) 507 Blairwood Drive, Apt. 12-D, Enterprise, AL 36330. Res: (334) 347-1000. Dy: Student Pilot. Time: 110 Hrs.

Blair, Patrick E., (CPT) (M94) 107 Rainbow Street, Clarksville, TN 37042-5527. Dy: (502) 798-4390. Res: (615) 645-7749. S: Lisa. Dy: HHT-2 17 Cav, Fort Campbell, KY. RW Qual. Time: 190 Hrs.

Blevins, Wayne A., (2LT) (M94) (Austin) 204 Knobloch Drive, Anderson, SC 29625. Dy: (803) 224-3392.

Blum, Gustavo E., (CPT) (M87) (Gus) P.O. Box 620358, Fort Rucker, AL 36362-0358. Dy: (334) 255-3100. Res: (334) 347-6483. Dy: Chief of Protocol, USAUSA/NC. Rtg: AA. RW Qual. Time: 760 Hrs. AM1. Life Member.

Bobek, Michael E., (CPT)(P) (M89) 111 PennStation, Savannah, GA 31410. Dy: (912) 352-6473. S: Kim. Dy: HHC, 3/160th SOAR (A), Hunter AAF, GA. Rtg: SAA MTP. Time: 1,600 Hrs.

Bodeison, Mario A., (1LT) (M93) 1001 Twin Creek Drive, No. 1210, Killeen, TX 76543. Dy: (817) 288-1471. Dy: UH60 Platoon Leader, B Co, 4-22th Avn, Fort Hood, TX.

Boeding, Michael, (CPT) (M92) 3604 Cadet Sheridan Road, No. B, Wahiawa, HI 96786-3658. Dy: (808) 656-1114. Res: (808) 624-6925. S: Laura. Dy: Asst Bde S3, Wheeler Army Airfield. Rtg: AA. RW Qual. Time: 980 Hrs.

Boehnik, Matthew A., (CPT) (M90) (Bink) 105 B Woodview Drive, Ozark, AL 36360-8210. Res: (334) 774-1475. S: Dawn. Dy: AOAC, A Co, 1/145th Avn, Fort Rucker, AL. Rtg: AA. RW Qual. FW Qual. Time: 650 Hrs.

Boham, Robert S., (CPT) (M92) (Bob) 103

Chickaw Road, Enterprise, AL 36330. S: April. Dy: 45th Medical Company (Air Amb), Ansbach, Germany. RW Qual. Time: 500 Hrs. Life Member.

Bonham, John W., (2LT) (M95) 185 West Main Street, Daleville, AL 36322. Dy: (334) 255-3311. Res: (334) 503-9954. Dy: Student Pilot, D Co, 1-145 Avn Regt. Time: 120 Hrs.

Bonnell, Brett L., (CPT) (M92) Route 1, Box 1753, Kempner, TX 76539. Dy: (817) 288-5560. Res: (817) 542-5991. S: Diana. Dy: F Troop, 1/7 Cav Regt, APO AE 09140. Rtg: AA. RW Qual. Time: 300 Hrs.

Book, Robert J., (CPT) (M89) (Jeff) D Troop, 2-6 Cavalry, CMR 416, Box 100, APO AE 09140. Dy: Avn Maint Co Cdr. RW Qual. Time: 650 Hrs. AM1.

Bora, Silviu F., (CPT) (M91) (Sal) 523 Hickorywood, Fayetteville, NC 28314. RW Qual. Time: 489 Hrs.

Borkowski, Lawrence J., (CPT) (M94) (Larry) 137 Brian Court, Daleville, AL 36322-9575. Dy: (334) 255-9960. Dy: IERW Phase Cdr, HHC, 1/145th Avn.

Bormann, James F., (CPT) (M90) (Jim) 32 Vernon River Drive, Savannah, GA 31419. Dy: (912) 352-5882. Res: (912) 927-6599. S: Cheri. Dy: HHC, 1-24th Avn, Hunter AAF.

Boyce, Lance P., (2LT) (M93) A Troop, 2-6 Cav, CMR 416, Box 29, APO AE 09140. Dy: A Troop, 2-6 Cav, 11th Avn Bde.

Boylan, Steven A., (CPT) (M89) (Steve) 70 Lexington Drive, Richmond Hill, GA 31324. Res: (912) 756-5776. S: Michelle. Dy: Chief, Plans & Strategy PAU, US Space Command, Peterson AFB, CO. Rtg: SAA. RW Qual. Time: 1,525 Hrs. Past Chapter Officer.

Bracewell, Brent E., (CPT) (M92) (Omar) HHC, 4th Bde, CMR 454, Box 2988, APO AE 09250. S: Ann. Dy: Company Commander, C Company, 7-1 Avn Bn, 4th Avn Bde, 3rd Inf Div. RW Qual. Time: 200 Hrs.

Braddom, Steven R., (2LT) (M93) 5186 Janine Street, Fort Bliss, TX 79906. Dy: (915) 568-5822. Res: (915) 564-4040. S: Jennifer. Dy: Plt Ldr, S Troop, 4/3 ACR. RW Qual. Time: 230 Hrs.

Brandon, James M., (CPT) (M89) (Jim) 40 K Smith Place, West Point, NY 10996-1923. Dy: (914) 938-4041. Res: (914) 446-7065. S: Marina. Dy: Admissions Officer, USMA, West Point, NY. Rtg: AA. RW Qual. Time: 700 Hrs.

Brannstrom, Kurt R., (1LT) (M92) 207th Avn Co, Unit 29231, Box 142, APO AE 09102. S: Diane. Dy: Fixed Wing Platoon Leader, Heidelberg, Germany. Rtg: AA. RW Qual. FW Qual. Time: 580 Hrs.

Brenneman, Jerome S., (2LT) (M94) P.O. Box 620741, Fort Rucker, AL 36362-0741. Dy: (334) 255-9414. Res: (334) 598-5708. Dy: D Co, 1/145th Avn Regt.

Bricker, Paul W., (CPT)(P) (M85) 2409 Ridge Road Drive, Alexandria, VA 22302. Dy: (703) 325-8675. Dy: Recorder, DA Secretariat, PER-SCOM. Rtg: SAA. RW Qual. Time: 1,200 Hrs.

Bridgers, Don E., (CPT) (M92) C Co, 7-22th Avn Regt, Unit 20197, APO AE 09165. S: Karla. Dy: Co Cdr, Fliegerhorst Kassel, Hanau, Germany. Rtg: MTP. RW Qual. Time: 600 Hrs.

Brocke, Jason M., (1LT) (M91) 6606 Hanley Court, Fayetteville, NC 28314. Dy: (910) 396-2570. Res: (910) 867-6319. S: Mall. Dy: Bn Asst S3, 1-159th Avn. RW Qual. Time: 500 Hrs.

Brockhard, Douglas L., (1LT) (M95) 1704 Caprock Drive, Killeen, TX 76542-3618. Dy: (817) 287-9828. Res: (817) 526-4610. S: Melaine. Dy: C Troop, 3-6 Cav Bde. RW Qual. Time: 575 Hrs.

Brosig, Max A., (2LT) (M95) 104 Weeks Drive, No. 10, Enterprise, AL 36330. Dy: (334) 255-9000. Res: (334) 347-2866. Dy: Student in Flight School. Fort Rucker, AL. Time: 33 Hrs.

Brosig, James M., (CPT) (M89) (Jim) Ragin' Cajun Chap VP Prog. 411 Eissman Road, Apt. 1, Leesville, LA 71446. Dy: (318) 531-0210. Res: (318) 239-0456. Dy: JRTC Opns Group/Avn Observer/Controller. Rig: AA. RW Qual. Time: 1,000 Hrs. Vp, Programs, Ragin' Cajun Chapter.

Brown, Carlos J., (2LT) (M94) P.O. Box 620945, Fort Rucker, AL 36362-0945. Dy: (334) 255-9090. Res: (334) 598-2182. S: Nicole. Dy: D Co, 1145th Avn.

Brown, Gregory S., (CPT) (M89) (Greg) 21276 Rosetta Place, Ashburn, VA 22011. Dy: (202) 373-6629. Res: (703) 724-0122. S: Dawn. Dy: DIA, Washington, DC. Rig: AA. RW Qual. Time: 600 Hrs./Cbt 30 AM/1.

Brown, Jeffrey D., (CPT)(PI) (M94) (Jeff) 109 Live Oak Drive, Enterprise, AL 36330. Dy: (334) 255-2600. S: Wanda. Dy: Aide-de-Camp. RW Qual. Time: 870 Hrs.

Brown, Robert S., (CPT) (M93) (Scott) 406 Larchmont Road, Fayetteville, NC 28311. Dy: (910) 396-1072. Res: (910) 822-6056. S: Monica. Dy: B Co, 3-229th Avn, Commander. RW Qual. Time: 650 Hrs./Cbt 75

Brown, Steven K., (CPT) (M90) (Steve) 7-227th Avn Bn, Unit 20197, Box 136, APO AE 09165. S: Carol. Dy: HHC, 4 Avn Bde, 1 AD, Hanau, Germany. Rig: AA. RW Qual. Time: 2,300 Hrs./Cbt 45

Brucker, Todd E., (1LT) (M91) 1001 Twin Creek Drive, Apt. 1808, Killeen, TX 78543. Dy: (817) 288-9629. Res: (817) 690-8916. Dy: S-1, 15th MI Bn(AE), Fort Hood, TX. RW Qual. FW Qual. Time: 1,100 Hrs.

Bruggemeyer, Kurt R., (CPT) (M88) 15 Jack Snipe Court East, Richmond Hill, GA 31324. S: Patti.

Brunson, Kerry P., (CPT) (M89) (KB) 801 End O Trail, Harrier Heights, TX 76543-6016. Dy: (817) 288-3465. Res: (817) 698-1360. S: Michelle. Dy: Cdr, D Troop, 3-4 Cav, Fort Meade, TX. Rig: AA. RW Qual. Time: 850 Hrs.

Bubnick, Wayne E., (CPT)(PI) (M94) 34 Willowcrest Court, St. Peters, MO 63376. Dy: (314) 263-5613. Res: (314) 928-8509. S: Rose Mary. Dy: Avn Log Off, ATCOM. Rig: MTP. RW Qual. Time: 850 Hrs.

Burgess, Alexander H., (2LT) (M91) (Alex) 6721 St Julian Way, Fayetteville, NC 28314. Res: (910) 867-5391. Dy: 3/27th F-A, (MLRS), Fort Bragg, NC. Past Chapter Officer.

Busch, Steven R., (CPT) (M90) 924 Danforth Place, Arlington, TX 76017. Dy: (800) 856-3801. Res: (817) 472-0576. S: Susan. Dy: Advanced Civil Schooling, Univ. of Texas. Rig: AA. RW Qual. Time: 900 Hrs./Cbt 15 AM/1. Past Chapter Officer.

Byrne, Alfred J.T., (CPT) (M89) (J.T.) 207th Avn Co, Unit 29231, Box 34, APO AE 09102. S: Vicki. Dy: Operations. RW Qual. FW Qual. Time: 802 Hrs./Cbt 104 AM/1.

CCCCCCCC

Cain, Jacqueline, (CPT) (M91) (Jackie) 208C Quarter Trail, Newport News, VA 23602. Dy: (804) 878-3065. Res: (804) 887-5477. Dy: Company Cdr, 3rd Staff & Faculty, 765th Trans Bn. Rig: AA. RW Qual. Time: 850 Hrs./Cbt 100 AM/2.

Campbell, Charles B., (CPT) (M91) (Brent) B Co, 4-501st Avn Regt, APO AP 96208. S: Ashley. Dy: Platoon Leader. B Co, 4/501st ASB, Camp Page, Korea. RW Qual. Time: 560 Hrs.

Camp, Andrew C., (CPT) (M88) (Drew) P.O. Box 348, Fort Drum, NY 13603. Dy: (315) 772-3266. Res: (315) 773-2410. S: Kelly. Dy: Assistant S-3, 10th Avn Bde, Fort Drum, NY. Rig: SAA. RW Qual. Time: 1,100 Hrs./Cbt 200 AM/2, 1V.

Canonic, Peter J., (2LT) (M93) 1503 Zaigon Place, Colorado Springs, CO 80925. Dy: (719) 526-2708. Res: (719) 574-2878. Dy: HHC, XO. RW Qual. Time: 165 Hrs.

Carlie, Christopher, (CPT) (M89) (Chris) Unit 467, Box 5332, APO AE 09066. S: Sandra. Dy: Company Commander, A Co, 5-158th Avn Regt. Rig: MTP. RW Qual. Time: 2,100 Hrs./Cbt 130 AM/1.

Carlisle, Leslie S., (1LT) (M92) 10017 Stony Creek Drive, Sanford, NC 27330. Res: (919) 499-0469. S: Vincent. Dy: 18th Avn Bde. RW Qual. FW Qual. Time: 300 Hrs.

Carpenter, Eric R., (2LT) (M94) 4132 Westmeadow, No. 207, Colorado Springs, CO 80906. Dy: (709) 526-5095. Res: (709) 527-1981. S: Leah. Dy: Asst S-1, HHC, 1-4th Avn, Fort Carson.

Carr, Leo V., (CPT) (M94) 2640 Leoli Drive, Colorado Springs, CO 80922. Dy: (719) 526-0220. Res: (719) 380-5484. S: Lisa. Dy: 571st Medical Company, Fort Carson, CO. Rig: MTP. RW Qual. Time: 900 Hrs./Cbt 45 AM/1.

Carroll, Clarence L., (1LT) (M93) 109 Graham Place, Fort Bragg, NC 28307. Dy: (910) 396-4343. Res: (910) 487-0015. S: Michelle. Dy: Special Mission Platoon Leader, C Co, 2/82 Avn, Fort Bragg, NC. RW Qual. Time: 500 Hrs.

Carroll, Robert J., (CPT) (M87) (Bob) 5185 Cracker Jack Lane, Apt. A, Fort Irwin, CA 92310. Res: (619) 386-2507. S: Diana. Dy: Assault Company Trainer, NTC, Fort Irwin, CA. Rig: AA. RW Qual. Time: 750 Hrs.

Carrow, Robin P., (CPT) (M94) (Rob) 2168 Commissary Circle, Odenton, MD 21113. Dy: (301) 677-2794. Res: (410) 674-1234. S: Did. Dy: RG Meade, Fort Meade, MD. RW Qual. Time: 1,200 Hrs. Past Chapter Officer.

Cassella, James P., (CPT)(M95) (Jim) 4049 Soda Mountain Drive, Apt. C, Fort Irwin, CA 92310. Dy: (619) 386-5796. Res: (619) 386-7723. S: Yersi. Dy: Chief, Visual/Info, NTC, and Sr. Public Affairs Trainer, Past Chapter Officer.

Catchings, Nicholas S., (1LT) (M93) (Senn) B Troop, 6th Cavalry, CMR 416, Box 390, APO AE 09140. S: Camille. Dy: B Troop, 6-4 Cavalry, 11th Avn Regt, Ilesheim, Germany. RW Qual. Time: 520 Hrs.

Cerney, Kenneth A., (CPT) (M85) 241 Metz Road, Seaside, CA 93955. S: Ellen. Dy: Presidio of Monterey. Rig: SAA. RW Qual. Time: 1,500 Hrs.

Chase, Margaret A., (1LT) (M93) HHC, 7-227 Avn. Regt., Unit 20197, Box 247, APO AE 09165. S: Jaime. Dy: Battalion Adjutant. RW Qual. Time: 350 Hrs.

Chapman, David P., (CPT) (M92) 12 Boyce Place, Fort Rucker, AL 36362. Dy: (334) 255-1266. Res: (334) 598-9214. S: Monica. Dy: Cdr, A Co, 1-13th Avn Regt. RW Qual. Time: 800 Hrs. AM/1.

Chase, Kenneth D., (1LT) (M93) 5210A Montague Loop, Fort Bliss, TX 79906-4018. Dy: (915) 568-8041. Res: (915) 566-8239. S: Ann Marie. Dy: Aide de Camp. JTF-6, Fort Bliss, TX.

Chasteen, Chad E., (2LT) (M94) 81 N. Harris, Fort Rucker, AL 36362. Res: (205) 307-3707. S: Jessica. Dy: AVOBC Student. RW Qual. Time: 148 Hrs.

Cherney, David R., (2LT) (M94) 71 A.M. Windham Drive, No. 300, Daleville, AL 36322. Res: (500) 445-7775. Dy: NTC, Fort Irwin, CA. RW Qual. Time: 180 Hrs.

Chism, Richard A., (CPT) (M89) (Rich) 19 Carvassack Drive, Bloomingdale, GA 31302. Res: (912) 748-8429. S: Rachael. RW Qual. Time: 675 Hrs. Past Chapter Officer.

Choquette, Sean M., (2LT) (M93) 230 General Grant Drive, Sackets Harbor, NY 13685-9509. Dy: (315) 772-8231. Res: (315) 646-8231. Dy: Platoon Leader (Avn), Fort Drum, NY. Rig: AA. RW Qual. Time: 250 Hrs.

Christensen, Kevin J., (CPT) (M91) A Co, 4-501st Avn, Box 66, APO AP 96208. S: Amber. Dy: Company Commander, Camp Page, Korea. RW Qual. Time: 1,055 Hrs.

Christensen, Teona M., (CPT) (M90) 110 Azalea Court, Clarksville, TN 37042. Dy: (502) 798-3272. Res: (615) 551-4020. Dy: S-4, 6-101st Avn, Fort Campbell, KY. RW Qual. Time: 300 Hrs. Life Member.

Chudy, Mark V., (1LT) (M93) 167 B Lower Brick Row, Fort Riley, KS 66442. Dy: (913) 239-2572. Res: (913) 784-4856. S: Michelle. Dy: 3/5, 1-1 Avn, Platoon Leader. RW Qual. Time: 500 Hrs.

Clark, Brett M., (1LT) (M93) 183 Whitehall Drive, Clarksville, TN 37042. Dy: (502) 798-2056. Res: (615) 552-8655. S: Susan. Dy: Platoon Leader, B Co, 9/101st Avn. Regt. Fort Campbell. Time: 400 Hrs.

Clegg, Joseph F., (CPT) (M87) (Joe) 10 Johnson Street, Fort Rucker, AL 36362-5000. Dy: (334) 255-0101. Res: (334) 598-8275. S: Julie. Dy: 1/145th Avn Regt, A Co. Rig: SAA. RW Qual. Time: 1,300 Hrs./Cbt 50 AM/1.

Clifford, Frederick E., (1LT) (M91) (Fred) 1951 Timberline Way, Clarksville, TN 37042. Dy: (502) 798-5203. Res: (615) 551-3781. Dy: HHC, 1-101 Avn, Fort Campbell, KY. RW Qual. Time: 700 Hrs.

Climer, Charles T., (CPT) (M87) (Tom) 144 Whitehall Drive, Clarksville, TN 37042. Dy: (502) 798-7949. Res: (615) 647-2058. Dy: HHC, Avn Bde, 101st Avn Div, Fort Campbell, KY. Rig: AA. RW Qual. Time: 900 Hrs.

Cochran, Bradley J., (CPT) (M93) (Brad) PSC 2, Box 1637, APO AA 34002-5000. S: Martha. Dy: S4, 128th Avn Bde. Rig: MTP. RW Qual. Time: 1,320 Hrs.

Code, Sean T., (1LT) (M94) CMR 454, Box 2464, APO AE 09250. Dy: Katterbach, Kasterne.

Colcord, Scott R., (1LT) (M94) A Co, 4-501st Avn Regt, Box 119, APO AP 96208. Dy: Aero-scout Platoon Leader. RW Qual. Time: 400 Hrs.

Cole, Kenneth C., (2LT) (M94) (Ken) 507 Brienwood, No. 16C, Enterprise, AL 36330. Res: (334) 347-2127. S: Daltah. Dy: Flight Student.

Collins, Jae D., (CPT) (M89) (Jae Bo) C Company, 3-58 Aviation, CMR 430, Box 736, APO AE 09066. S: Sara. Dy: Cdr, C Co, Westaband, Germany. RW Qual. Time: 1,250 Hrs. AM/1.

Conmstock, James M., (CPT) (M93) 57 Lopa-neg Avenue, Box 78, Guaynabo, PR 00969. Dy: (809) 273-3281. Res: (809) 790-3356. S: Deborah. Dy: Avn Section O/WHQ Co Cdr, Fort Buchanan, PR. RW Qual. Time: 675 Hrs.

Connors, Scott P., (CPT) (M91) 9842A Sandy Creek Road, Fort Drum, NY 13603. Dy: (315) 772-5295. Res: (315) 773-7278. S: Lee. Dy: Commander, HHC, 10th Avn. Brigade. Rig: AA. RW Qual. Time: 600 Hrs.

Consani, Quint A., (CPT) (M91) (Ponyboy) P.O. Box 8428, Woodland Park, CO 80966-8428. Dy: (719) 526-3478. Res: (719) 687-5603. Dy: Brigade Assistant S-1, 4th Bde. Rig: MTP. RW Qual. Time: 500 Hrs. Vp, Chapter Awards, Peaks Peak Chapter.

Conyers, Todd Z., (CPT) (M83) HHC 2/501st, Unit 15168, APO AP 96271-0146. S: Dottie. Dy:

Commander, HHC 2/501, Camp Humphreys, Korea. Rtg: AA. RW Qual. Time: 850 Hrs./Cbt 50 AM2.

Cook, James C., (2LT) (M94) (Cameron) 100 A.M. Windham Drive, No. 706, Daleville, AL 36322. Dy: (334) 255-9412. Res: (334) 598-6773. Dy: Ops Off., D Co., 1-145th Avn. Rtg: AA. RW Qual. Time: 160 Hrs.

Cooper, Curt S., (CPT) (M88) (Coop) 192 Lakeview Drive, Daleville, AL 36322-9334. Dy: (334) 255-4241. Res: (334) 598-8609. S: Loreta. Dy: E Co., 1-212th Avn Regt. Cdr. Rtg: IP. RW Qual. FW Qual. Time: 1,400 Hrs./Cbt 100 AM2.

Corcoran, James M., (CPT) (M89) (Jim) 14 Stratford Lane, Enterprise, AL 36330. Dy: (334) 255-3395. Res: (334) 393-5092. S: Nancy. Dy: Commander, HHD, 1/11th ATB, Fort Rucker, AL.

Corkey, Christopher, (CPT) (M86) 14 Little Big Horn Drive, Fort Irwin, CA 92310. Dy: (619) 360-4280. Life Member.

Comello, John R., (CPT) (M94) (Old Bill) Chapter VP Prog., 213 Argonaut, Apt. 52, El Paso, TX 79912. Dy: (915) 668-9314. Res: (915) 544-0456. Dy: Commander, Stetson Troop 4/3 ACR. RW Qual. Time: 600 Hrs. Vp, Programs, Old Bill Chapter.

Covert, Robert C., (CPT) (M90) 3729 Breckenridge Drive, El Paso, TX 79938. Dy: (915) 568-8441. Res: (915) 592-9874. S: Kimberley. Dy: 4th Squadron, 3rd ACR. Rtg: AA. RW Qual. Time: 600 Hrs.

Cristy, William R., (CPT) (M94) (Will) 203 East Emerald Drive, Enterprise, AL 36330. Dy: (334) 255-8433. Res: (334) 347-7194. S: Maureen. Dy: Airfield Ops Officer, Cairns Army Airfield. RW Qual. Time: 650 Hrs.

Crogan, R. Richard E., (CPT) (M93) 2004 Theresa Circle, Harker Heights, TX 76543. Dy: (817) 287-5735. Res: (817) 698-3002. Dy: Commander, D Troop, 3/8 Cav, Fort Hood, TX. Rtg: MTP. RW Qual. FW Qual. Time: 1,100 Hrs.

Crozier, William E., (CPT) (M88) (Bill) 38 Beaver Run Drive, Savannah, GA 31419. Res: (912) 921-0573. S: Tammy. Dy: Bn Adjutant, 224 MI Bn (AE). Rtg: SAA. RW Qual. FW Qual. Time: 1,300 Hrs./Cbt 50 AM1.

Culkin, David T., (1LT) (P) (M91) (Dave) 723 Allison Avenue, Apt. 2, Manhattan, KS 66502. Dy: (913) 239-6699. S: Michaela. Dy: Battalion S-2, 1-1 Avn Regt. RW Qual. Time: 435 Hrs.

Cumble, Robert M., (CPT) (M86) (Mike) 114 Chapelwood Drive, Enterprise, AL 36330. Dy: (334) 255-3808. Res: (334) 393-0728. S: Jane. Dy: Avn Battle Lab Supt Team, Fort Rucker, AL. Rtg: SAA. RW Qual. Time: 2,400 Hrs./Cbt 48 AM1/V.

Cunningham, Gary L., (2LT) (M93) 229 Weeks Drive, Enterprise, AL 36330. Res: (205) 347-5109. S: Mary. Dy: C Co., 2-55th Fort Drum, NY. RW Qual. Time: 1,300 Hrs./Cbt 75 AM2.

Cunningham, John R., (CPT) (M86) (Robert) HHC, CMTC, CMR 414, Box 68, APO AE 09173. S: Tracy. Dy: Attack Co Observer/Controller. Rtg: SAA. RW Qual. Time: 1,350 Hrs. AM1. Treasurer, Bavarian Chapter. Past Chapter Officer.

Curtis, Joseph S., (1LT) (M91) C Troop, 2-6 Cavalry, CMR 416, Box 108, APO AE 09140. S: Deborah. Dy: Platoon Leader, Ilesheim, Germany. Rtg: AA. RW Qual. Time: 550 Hrs.

Cutchin, Allan H., (1LT) (M93) CMR 454, Box 3191, APO AE 09250. S: Sandy. Dy: Assistant S-3. Rtg: AA. RW Qual. Time: 400 Hrs.

Cutler, Christopher, (2LT) (M95) 140 Woodfield Place, Enterprise, AL 36330. Dy: (334) 255-9290. Res: (334) 347-8996. Dy: Avn Student, AOBC.

Cutright, Douglas W., (1LT) (M94) 1406 Rose

Avenue, Kileen, TX 76543. Dy: (817) 288-9840. Res: (817) 699-3596. S: Sarah. Dy: 15th MI Bn, Fort Hood, TX. RW Qual. FW Qual. Time: 300 Hrs.

Cyr, Michael P., (CPT) (M88) (Mike) 7636 Tulington Road, Toano, VA 23168. Dy: (804) 878-3588. Res: (804) 566-0036. S: Linda. Dy: Ops Officer, Fort Eustis. RW Qual. Time: 1,000 Hrs.

Cyruulik, John M., (CPT) (M91) (Gabby) HHC, 4th Avn Bde, 3rd, CMR 454, Box 1959, APO AE 09250. Dy: HHC XO, 4th Bde, 3rd Rgt. AA. RW Qual. Time: 475 Hrs. Treasurer, Wings Of The Marine Chapter.

DDDDDDDDDD

Dabbs, Willis N., (CPT) (M90) (Will) 1015-2 Chestnut, Fort Wainwright, AK 99703. Dy: (907) 353-9752. Res: (907) 356-7890. S: Cassie. Dy: 4-123rd Avn. Asst Bn S-3/Inf LNO. Rtg: AA. RW Qual. Time: 600 Hrs.

Darrow, Keith R., (CPT) (M84) 2704 Brookhaven Drive, Atlanta, GA 30319. Dy: (404) 261-2047. Res: (404) 261-2047. S: Sheryl. Dy: Instructor-USMA, West Point, NY. Rtg: SAA/IF. RW Qual. FW Qual. Time: 1,820 Hrs. Life Member.

Daughtry, Marcus A., (1LT) (M93) (Barn-Barn) P.O. Box 5881, Fort Hood, TX 76544-0881. Dy: (817) 287-5979. Res: (817) 776-4203. S: Scherelle. Rtg: AA. RW Qual. Time: 450 Hrs. Life Member.

Daum, Richard S., (CPT) (M91) (Rich) 109 Fieldbrook Drive, Enterprise, AL 36330. Dy: (334) 255-2493. Res: (334) 393-0061. S: Michelle. Dy: ORSA, Aviation Battle Lab Support Team, USAFAV. RW Qual. Time: 800 Hrs./Cbt 35 AM1/V.

Davis, Timothy S., (CPT) (M90) (TD) 2601 Tyn Town Road, Clarksville, TN 37042-7020. Dy: (615) 798-2212. Res: (615) 553-0770. S: Debbie. Dy: Avn Maint Officer, B Co., 8/101st Avn Regt. Rtg: MTP. RW Qual. Time: 625 Hrs.

Day, Patrick A., (CPT) (M91) 3330 Trevelyan Drive, Manhattan, KS 66502-2132. Dy: (913) 239-3817. Res: (913) 537-1997. S: Sheila. Dy: 82nd Med Co. (AA), Fort Riley, KS. Rtg: SAA. RW Qual. FW Qual. Time: 1,600 Hrs./Cbt 150

Debany, Richard B., (1LT) (M92) (Rich) 2110 Westchester Drive, No. 1, Manhattan, KS 66502. Dy: (913) 239-6717. Res: (913) 539-6748. Dy: B Co., 4-1 Avn Regt, Assault Platoon Leader. RW Qual. Time: 375 Hrs.

Decker, Andrew B., (1LT) (M92) C Co., 7/158th Avn Regt, CMR 408, Box 1414, APO AE 09182. Dy: Pl Ldr, Giebelstadt, Germany. RW Qual. Time: 300 Hrs.

DeCrane, Sharon E., (1LT) (P) (M91) (Shar) 1671 Fort Campbell Blvd., No. X3, Clarksville, TN 37042-3570. Dy: (502) 798-3128. Res: (615) 565-7868. Dy: S1, 4-101st Avn, Fort Campbell, KY. RW Qual. Time: 500 Hrs.

DeLeon, Richard F., (CPT) (M91) (Rick) 95-017 Kuhalehale, Apt. 322, Milani, HI 96789-1604. Dy: (808) 656-2201. Res: (808) 292-1496. Dy: XO, H Co (AVIM), 25th Avn Regt. Rtg: SAA. RW Qual. Time: 1,233 Hrs. Secretary, Alpha Chapter.

Delgado, Asdrubal E., (1LT) (M95) (A.D.) 178 Village Heights, Enterprise, AL 36330. Dy: (334) 255-9030. Res: (334) 347-8842. S: Damaris. Dy: D Co., 1/145th Avn.

Deller, Sean T., (CPT) (M88) 431 Habersham Street, Savannah, GA 31401. Dy: (912) 353-2437. Dy: Aviation Brigade, 24th HHC, Hunter Army Airfield, GA. Rtg: AA. RW Qual. Time: 850 Hrs.

Dement, Ronald W., (CPT) (M89) (Ron) 609 Northampton Road, Fayetteville, NC 28303. Dy: (910) 396-8002. Res: (910) 860-0882. S: Jane.

Dy Operations Officer, A Co., 2-159th Avn Regt, Fort Bragg, NC. RW Qual. Time: 630 Hrs./Cbt 51 AM2.

Demirjian, Michael E., (2LT) (M91) 5641-1 Lockridge Loop, Fort Hood, TX 76544. Dy: (718) 269-3465. Res: (718) 539-7328. S: Courtney. Dy: Pl Ldr, 3-4 Cav, DTroop, Fort Hood, TX. RW Qual. Time: 900 Hrs.

DePriest, Francis J., (1LT) (M91) A Co., 5/158th Avn, CMR 467, Box 6888, APO AE 09296. S: Catherine. Dy: Pl Ldr, A Co., 5/158th Avn, 12th Avn Bde. RW Qual. Time: 500 Hrs.

Diaz, Brian J., (CPT) (M92) (B.J.) 3637 Porter Loop, No. B, Wahiawa, HI 96786-3681. Dy: (808) 477-7904. Res: (808) 624-3443. S: Heather. Dy: Aide-de-Camp to the LIS Commander in Chief of the Pacific Command. RW Qual. Time: 1,200 Hrs. Past Chapter Officer.

Diaz-Freytes, Wilfredo, (CPT) (M91) (Willie) B Co., 70th Trans Bn AVIM, Unit 23719, Box 333, APO AE 09028. S: Maria. Dy: AD Executive Officer, Rtg: MTP. RW Qual. Time: 390 Hrs.

Dick, Randy J., (1LT) (M91) 101 S. Twin Creek Drive, Apt. -3B12, Killeen, TX 76543-4727. Dy: (817) 288-1412. Dy: A Co., 1-227 Avn Regt, 1 Cav Div.

Dickson, Mark A., (CPT) (M94) 517-D Rm Rock Terrace, Fort Riley, KS 66442. Dy: (913) 784-6630. S: Josephine. Dy: 4th Combat Aviation Brigade, 1st ID (M).

Dillon, Brian E., (CPT) (M91) 7E Luy, Fort Bragg, NC 28307. Dy: (910) 396-9733. Res: (910) 436-9180. S: Amy. Dy: S-1, 3/29th, Fort Bragg, NC. RW Qual. Time: 500 Hrs.

Diotte, Gerald R., (CPT) (M88) (Butch) 875 Ridgeloop Loop, North Pole, AK 99705. Dy: (907) 353-9752. Res: (907) 488-4309. S: Amy. Dy: Ass. S-3 HHC 4/123rd Rgt. MTP. RW Qual. Time: 950 Hrs./Cbt 50 AM1.

Diwa, Manuel C., (CPT) (M95) (Manmy) 804 Hilton Drive, Fayetteville, NC 28311. Dy: (910) 396-6844. Res: (910) 468-6489. S: Monica. Dy: Commander, HHC, 2-159th Aviation Regiment, Fort Bragg, NC. Rtg: AA. RW Qual.

Doane, Barrett S., (CPT) (M91) (Shel) 4th Brigade, 7-1 Avn Regt, CMR 454, Box 1662, APO AE 09250. S: Cindy. Dy: OH-56D Pilot, Katterbach, Germany. RW Qual. Time: 650 Hrs.

Dobias, James A., (2LT) (M94) 41 Kirby Street, Fort Rucker, AL 36362-2237. S: Dawn. Dy: 224th MI Bn (AE), Hunter Army Airfield, Savannah, GA. RW Qual. FW Qual. Time: 700 Hrs.

Doshing, Andrew D., (CPT) (M89) 94-650 Kaupapa Loop, Milani, HI 96789. Dy: (808) 656-0996. Res: (808) 637-0942. Dy: G Co., 58th Avn Regt (Cdr), WAAF, HI. RW Qual. Time: 850 Hrs.

Donatucci, William S., (CPT) (M94) (Tooch) 610 Grandpine Avenue, Enterprise, AL 36330. Dy: (334) 255-5073. Res: (334) 393-2521. S: Sandy. Dy: 1/14th Avn, F Co. RW Qual. Time: 1,050 Hrs./Cbt 40

Donnangelo, Andrew T., (CPT) (M91) 55 Clonago Lane, Easton, NJ 07724. Dy: (908) 544-2526. Res: (908) 935-9382. S: Donna. Dy: Avnics Project Test Pilot, CECOM, Fort Monmouth, NJ. Rtg: SAA SIP. RW Qual. Time: 1,050 Hrs.

Donnelly, Robert C., (2LT) (M94) (Bob) 103 Woodley Drive, Enterprise, AL 36330. Dy: (334) 347-3212. Res: (334) 347-3212. Dy: D Co., 1/145th Avn Regt. RW Qual. Time: 160 Hrs.

Dorsett, Larry P., (CPT) (M91) (Larry) 1959 Leighton Court, Clarksville, TN 37043. Dy: (502) 798-2026. S: Suzanne. Dy: Asst S-4, 17th Avn Bde, Yongson, Korea. Rtg: SAA MTP. RW Qual. Time: 850 Hrs.

Dosier, David A., (1LT) (M82) 4308-1 Wolford, Fort Riley, KS 66442. Dy: (910) 239-3897. Res:

(913) 784-4970. S. Dawn. Dy: D Twp. 1-4 Cav. Fort Riley, KS. RW Qual. Time: 600 Hrs.

Douthett, Robert L., (CPT) (M88) (RD) AAAA Nal Member-at-Large. 2053 A Womer Park. Fort Campbell, KY 42223. Dy: (502) 798-7477. Res: (615) 431-4681. S. Paige. Dy: Abn Det. Cdr. 1/160th SOAR. Rtg: SAA. Time: 1,150 Hrs. NEB.

Draper, Michael B., (1LT)(P) (M91) 707 Trott Court. Fort Wainwright, AK 99703-1419. Dy: (907) 353-7283. Res: (907) 356-3316. S. Mary Jane. Dy: B Company, 4/123rd "Sugarbears", Fort Wainwright, AK. Rtg: AA MTP. RW Qual. Time: 400 Hrs.

Drennon, William S., (CPT) (M91) (Scott) 112 Ambleridge Road, Leesville, LA. Res: (504) 318-239-6687. S. Laurie. Dy: Sr. Medevac Observer/Controller, JRTC Ops Group, Fort Polk, LA. Rtg: MTP. RW Qual. Time: 700 Hrs.

Drew, Thomas R., (CPT) (M85) (Burl) 12300 Apache Avenue, Apt. 913, Savannah, GA 31419. Dy: (912) 352-6718. Res: (912) 921-1971. S. Kay. Dy: Company Commander, B Co, 1-24th Avn, Hunter Army Airfield, GA. Rtg: IP. RW Qual. Time: 1,800 Hrs./Cbt 50 AM/32V.

Driver, Mark M., (CPT) (M90) 81-165 Itohu Place, Haleiwa, HI 96712. Res: (808) 637-157. Dy: HHC Avn Bde, Schofield Barracks, HI. RW Qual. Time: 750 Hrs.

Drozieski, Graham R., (2LT) (M93) 71 A.M. Windham Drive, No. 604, Daleville, AL 36322. Dy: (334) 599-3311. Res: (334) 590-2682. Dy: Fort Drum, NY. RW Qual. Time: 150 Hrs.

Dudley, Bruce E., (2LT) (M94) P.O. Box 450, Fort Drum, NY 13603. Dy: (315) 772-4414. S. Tiffany. Dy: 3-25 AHB, Fort Drum, NY. RW Qual. Time: 185 Hrs.

Dunaway, Joe D., (CPT) (M85) 6836 St. Julian Way, Fayetteville, NC 28304. Res: (919) 864-7302. S. Anita. Dy: C Co, 1/801st, 17th Avn, Camp Page, Korea. Rtg: TP. RW Qual. Time: 1,500 Hrs.

Duncan, Joseph M., (CPT) (M91) 3431 Oak Lawn Drive, Clarksville, TN 37042-5899. Dy: (502) 798-3374. Res: (615) 431-4502. S. Trish. Dy: 2-101st Avn Regt, SA, Fort Campbell, KY. RW Qual. Time: 650 Hrs.

Duncan, Rodger T., (CPT) (M88) (Tom) 1939 Partridge Court, Fayetteville, NC 28304. Dy: (910) 396-9423. Res: (910) 864-8311. S. Betty. Dy: Commander, HHT, 4th Sqn, 2nd ACR, Fort Bragg, NC. Rtg: MTP. RW Qual. Time: 810 Hrs.

Dunford, Russell L., (CPT) (M83) 95-1038 Parkwood Street, Milani, HI 96789. Res: (808) 655-4978. S. Jennifer. Dy: Div Avn Maint Off, 25 ID (L), G4. Rtg: AA.

Dykes, David A., (CPT) (M90) 2812 Sweetbriar Drive, Tallahassee, FL 32312. Dy: (905) 678-3493. Res: (904) 386-7961. S. Patricia. Dy: Research Analyst, TRAC-VMSMR, Rtg: AA. RW Qual. Time: 800 Hrs./Cbt 65 AM/1. Past Chapter Officer.

Džubek, Christopher, (CPT) (M89) (Moose) 1807 Virginia Avenue, Copperas Cove, TX 76522. Res: (817) 547-6782. S. Susan. RW Qual. Time: 1,029 Hrs.

EEEEEEEEEE

Eberle, Mark A., (2LT) (M93) 2913 Cox Mill Road, Apt. K9, Hopkinsville, KY 42240. Res: (502) 886-1629. Dy: B Co, 9th/101st Avn.

Ebner, Gregory R., (CPT) (M88) (Greg) P.O. Box 33857, Fort Carson, CO 80913. Dy: (719) 526-2662. Res: (719) 540-057. Dy: Asst S-5/HHT, 1-10 Cav 4 ID (M), Fort Carson, CO. Rtg: AA. RW Qual. Time: 780 Hrs./Cbt 70 AM/1.

Eckerman, Lisa R., (2LT) (M94) 109 Cahaba Drive, Enterprise, AL 36330. Dy: (334) 255-3311. Res: (334) 347-1629. Dy: D Co, 1/145th Avn Regt.

Eckert, Joseph G., (CPT) (M91) (Savoey-8) 2504 Sherman Street, Killeen, TX 76543. Dy: (817) 288-9129. Res: (817) 634-0018. S. Cathy. Dy: Aviator, Medevac, 507th Med Co (AA), Rtg: MTP. RW Qual. Time: 700 Hrs.

Edmondson, Stephen C., (CPT) (M91) 910 Frontier Trail, Harker Heights, TX 76543. Dy: (817) 287-4213. S. Christy. Dy: HHC, 2-58th Avn, Fort Hood, TX.

Edwards, Jr., Donald W., (1LT) (M93) (Don) 1001 Twin Creek Drive, Apt. 1208, Killeen, TX 76543. Dy: (817) 288-7541. Res: (817) 690-7173. S. Yvette. Dy: F 502d Avn Regt, Fort Hood, TX. Rtg: MTP. RW Qual. Time: 370 Hrs.

Edwards, Jeffrey J., (2LT) (M91) 2111 Cheri Drive, Ozark, AL 36360. Res: (334) 445-0662. Dy: Student.

Edwards, Joseph A., (1LT) (M93) (Joe) C Co, 3-1 Avn, CMR 454, APO AE 09250. RW Qual. Time: 201 Hrs.

Edwards, Keith R., (CPT) (M90) 207 Turisula Road, Fort Ord, CA 93941-1623. Dy: (408) 865-2536. Res: (408) 899-9740. S. Mar. Dy: USASD w/Dutty at Naval Post Graduate School, Monterey, CA. RW Qual. Time: 1,200 Hrs. Past Chapter Officer.

Eichelberger, Scott, (CPT) (M89) 102 Smokehouse Lane, Cary, NC 27513. Dy: (919) 664-7619. S. Lois. Dy: Resident Training Detachment Chief, Raleigh, NC. Rtg: SAA. IP. RW Qual. Time: 2,000 Hrs.

Eichorst, Harold A., (1LT) (M92) (Andrew) 217 Apache Drive, No. 9D, Enterprise, AL 36330-2101. Dy: HHC, 1-2 Avn, Camp Mobile, Korea. RW Qual. FW Qual. Time: 585 Hrs./Cbt 35 AM/1.

Eldredge, Charles B., (CPT) (M89) (Chuck) 232 Candlebrook Court, Enterprise, AL 36330-2200. Dy: (334) 255-1351. Res: (334) 393-2232. S. Susan. Dy: AMOC, C Co, 1-139 Avn Regt. RW Qual. Time: 460 Hrs.

Ellis, Michael D., (1LT) (M93) (Mike) D Co, 2-2nd Avn Regt, Unit 15431, Box 581, APO AP 96257-0464. Dy: Maintenance Co XO, D Co, 2-2 Avn, 2D, Camp Stanley, Korea. RW Qual. Time: 225 Hrs.

Ells, Ronald L., (2LT) (M94) (Ron) 142 Traynor Avenue, Savannah, GA 31405. Dy: (912) 353-2682. Res: (912) 354-5131. S. Joelle. Dy: HSC, 924th Avn Spt Bn, Hunter Army Airfield. RW Qual. Time: 180 Hrs.

Enderle, Kimberly A., (CPT) (M88) 6466 Brookshire Street, Fayetteville, NC 28314. Dy: (910) 396-7422. Res: (910) 864-9520. Dy: Commander, D Co, 3-229th Aviation (Attack), Rtg: AA MTP. RW Qual. Time: 550 Hrs./Cbt 25 Hrs.

Engel, Craig A., (CPT) (M93) 5979C Harrell Place, Fort Polk, LA 71459. Dy: (318) 531-2028. Res: (318) 537-2762. S. Deborah. Dy: Observer/Controller, Avn Division, JRTC Operations Group. RW Qual. Time: 1,300 Hrs./Cbt 11

Erb, Edward E., (2LT) (M94) 112 Brian Court, Daleville, AL 36322. Dy: (334) 255-9090. Res: (334) 598-1833. S. Alexa. Dy: D Co, 1/145th Avn Regt, Rtg: AA. RW Qual. Time: 150 Hrs.

Erker, Erich, (CPT) (M84) 533 Pollard Road, Clarksville, TN 37042-3779. Dy: (502) 798-4080. S. Michele. Dy: 8/101st Avn Regt, Fort Campbell, KY. Rtg: MAA MTP. RW Qual. Time: 2,500 Hrs./Cbt 125 AM/1.

Esser, Donald R., (2LT) (M85) (Don) 2801 E. Andrews Avenue, Apt. M, Ozark, AL 36360-3558. Dy: (334) 255-9961. Res: (334) 445-1882. Dy: Student Pilot.

Evans, John R., (CPT) (M89) (Rattler) 1503

Pin Oak Court, Apt. 11, Radcliff, KY 40160-2464. Dy: (502) 272-1146. Dy: Student, Armor Advanced Course, Fort Knox, KY. Rtg: AA. RW Qual. Time: 700 Hrs./Cbt 30 AM/1, 1V.

Evans, Samuel S., (CPT)(P) (M85) (Sam) 19044 A Lexington Avenue, Great Lakes, IL 60068. Dy: (708) 926-6425. Res: (708) 473-3704. S. Reva. Dy: Group S4 Logistics Officer, 244th Avn Gp, Rtg: SAA TP. RW Qual. Time: 1,050 Hrs.

FFFFFFFFFF

Fabrizio, Robert P., (CPT) (M92) (Bob) 114 E. Sagebrush Lane, Savannah, GA 31419. Dy: (912) 767-2852. Res: (912) 927-7528. S. Stacy. Dy: C Co, 4-24 Avn Regt., Company Commander, Rtg: AA MTP. RW Qual. Time: 400 Hrs.

Falls, Donald G., (CPT) (M93) 3433 Little Stone Court, Fayetteville, NC 28311. Dy: (910) 396-1704. Res: (919) 488-1389. S. Megan. Dy: Company Commander, B1-229th (Attack), Fort Bragg, NC. RW Qual. Time: 385 Hrs.

Farnell, Christopher (CPT) (M91) (Chris) 708 Overton Drive, Clarksville, TN 37042. Dy: (502) 798-2038. Res: (615) 647-2978. S. Doris. Dy: HHC, 101st Avn Div (AASLT), Division G-3 Air, Fort Campbell, KY. RW Qual. Time: 415 Hrs.

Farris, Roger E., (1LT) (M92) (Roj) HHT, 6-6 Cav, 11th Avn Gr, CMR 416, Box 57, APO AE 09140. S. Michele. Dy: Squadron S-1, Rtg: AA. RW Qual. Time: 425 Hrs.

Fearing, Michael D., (CPT)(P) (M94) (Mike) HHC, CMTC, Unit 28208, Box 641, APO AE 09173. S. Kathryn. Dy: CMTC Observer Controller, Rtg: SAA. RW Qual. Time: 1,200 Hrs./Cbt 1 AM/1.

Feight, John S.D., (1LT) (M90) (Scott) 803 Mallard Court, Clarksville, TN 37042. Dy: (502) 798-5438. Res: (615) 431-5468. S. Tina. Dy: 6 Bn-101st Avn Bde, Fort Campbell, KY. RW Qual. Time: 500 Hrs.

Ferrell, John M., (2LT) (M94) 48 E Harris Drive, Fort Rucker, AL 36362-2351. Dy: (334) 255-9090. Res: (334) 598-1443. S. Jeanne. Dy: Flight Student, D Co, 1-145th Avn. RW Qual. Time: 180 Hrs.

Fessenden, Alan D., (CPT) (M85) (Al) P.O. Box 92, West Point, NY 10996. Dy: (914) 938-4041. Res: (914) 446-8322. Dy: Admissions Off., US Military Academy, Rtg: SAA. Time: 1,500 Hrs.

Feuerborn, Thomas A., (1LT) (M92) (Tom) 111 Lions Gate Road, Savannah, GA 31419. Dy: (912) 352-5790. Res: (912) 920-1084. S. Jamelle. Dy: Scout Platoon Leader, A1-24th Avn Regt, Hunter Army Airfield, GA. Rtg: AA. RW Qual. Time: 280 Hrs.

Feutz, John S., (CPT) (M94) 425 Larchmont Road, Fayetteville, NC 28311-0879. Dy: (910) 396-3884. Res: (910) 488-4374. Dy: Asst S3 (Plans), Rtg: AA. RW Qual. Time: 600 Hrs.

Fifer, Bruce E., (CPT) (M91) Savannah Chapter Treas., 601 Dyches Drive, Savannah, GA 31406-5715. Dy: (912) 352-6909. Res: (912) 925-6847. S. Sandee. Dy: S1, 924 Avn Spt Bn. RW Qual. Time: 370 Hrs. Treasurer, Savannah Chapter.

Fish, Charles A., (CPT) (M88) (Tony) 299th Sqdn (RNLA), PSC 112, Box 428, APO AE 09717. S. Judy. Dy: Exchange Officer, Deelen Airbase, The Netherlands. Rtg: SAA. IP. RW Qual. Time: 2,900 Hrs.

Fishburne, Elliott G., (2LT) (M94) (E. G.) 94 Harard Creek Drive, Enterprise, AL 36330. Res: (334) 393-4215. Dy: IERW Student, Fort Rucker, AL. Time: 85 Hrs. Life Member.

Fitzsimmons, Aaron P., (2LT) (M94) (Fit) P.O. Box 620325, Fort Rucker, AL 36362-5000.

Res: (334) 598-8749. Rtg: AA. RW/Qual. Time: 175 Hrs.

Fleckenstein, David S., (CPT) (M94) (Flock) A Co, 2501st Avn Regt, Unit 15210, APO AP 96271-0146.

Fleehar, Jeffrey J., (2LT) (M94) 128 Brian Court, Daleville, AL 36322. Res: (334) 598-1148. Dy: C Co, 1/145th Avn Regt, Apache/AH-64 AOC. RW/Qual. Time: 160 Hrs.

Fleisher, Scott T., (1LT) (M93) (Che) A Troop, 2-6 Cavalry, CMR 416, Box 29, APO AE 09140. S: Toni. Dy: Attack Platoon Leader. RW Qual. PW Qual. Time: 400 Hrs.

Fleetwood, Michael A., (CPT) (M88) (Mick) 956 Flintwood Drive, Fayetteville, NC 28314. Dy: (910) 436-1801. Res: (910) 664-8646. S: Sang Sun. Dy: 3d Bn, 1st Special Warfare Group (ABN), Masters Degree Student. Rtg: AA. RW/Qual. Time: 900 Hrs.

Flood, Albert L., (CPT) (M87) (Big Al) 106 W Miami Avenue, Cherry Hill, NJ 08002-3038. Dy: (800) 656-2557. Res: (809) 426-2867. S: Patti. Dy: Co Cdr, A Co, 4/25th Avn Regt, 25th ID (L). Rtg: AA. RW Qual. Time: 800 Hrs./Cbt 35 AM/1.

Foote, Anthony C., (1LT) (M92) (Foote) 825 Quail Lake Circle, Colorado Springs, CO 80906-4688. Dy: (719) 526-0297. Res: (719) 527-1005. RW Qual. Time: 360 Hrs.

Fortier, Norbert H., (CPT) (M87) (Bart) 6726 Doolittle Drive, Edwards, CA 93523. Dy: (805) 277-4717. S: Mindy. Dy: Experimental Test Pilot, Army Airworthiness Qual Test Dir. Rtg: AA. RW Qual. PW Qual. Time: 1,700 Hrs. Life Member.

Fox, Roy W., (CPT) (M94) 10 Donovan Lane, Fort Rucker, AL 36362. Dy: (334) 255-9518. Res: (334) 598-6509. S: Phyllis. Dy: HHC 1-10th Avn. Rtg: AA. Time: 750 Hrs.

Frawley, Parker L., (2LT) (M94) 108 Hargett Road, Daleville, AL 36322. Dy: (334) 255-9591. Res: (334) 598-8422. Dy: Avn Student, D Co, 1-145th Avn Regt. RW Qual. PW Qual. Time: 300 Hrs.

Friend, Daniel, (1LT) (M92) 906 Vernon Drive, Coppas Cove, TX 76522. Dy: (817) 287-8102. Res: (817) 542-6978. S: Kathy. Dy: 4/6 Cav, Fort Hood, TX. Rtg: AA. RW Qual. Time: 390 Hrs.

Fugate, Thomas M., (CPT) (M91) (Tom) 6 William Jay Court, Savannah, GA 31419. Dy: (912) 352-5790. Res: (912) 920-2704. S: Diana. RW Qual. Time: 500 Hrs.

Fullwood, Reginald Jr., (CPT) (M92) (Reggie) 7408 Hemlock Drive, No. 1003D, Lowville, NY 13367-1849. Dy: (315) 772-7890. Res: (315) 376-6413. S: Kathy. Dy: A Company, 3rd Bn, 25th Avn Regt Commander. RW Qual. Time: 800 Hrs.

Furlong, Matthew S., (1LT) (M94) 2419 Burtonwood Drive, Manhattan, KS 66502. Dy: (913) 239-3695. Res: (913) 537-1994. Dy: Adjutant, 4-1 Avn. RW Qual. Time: 600 Hrs.

Fuschak, Kim G., (CPT) (M92) Ragin' Cajun Chap. Treas., P.O. Box 852, Rosepine, LA 70659. Dy: Observer/Controller-JRTC, Fort Polk, LA. Rtg: AA. RW Qual. Time: 800 Hrs.

GGGGGGGGGG

Gallagher, Julie S., (2LT) (M94) 1078 Brookview, So. Ozark, AL 36360. Res: (334) 445-0024. S: John. Dy: D Co, 1/145th, Fort Rucker, AL. Time: 126 Hrs.

Garapota, Joseph, (CPT) (M91) 117 Saint Ives Drive, Savannah, GA 31419-8918. Dy: (912) 352-6867. Res: (912) 927-4240. S: Noel. Dy: A Co, 224th MI Bn (AE), Hunter Army Arsenal, GA. RW Qual. PW Qual. Time: 550 Hrs.

Garcia, Xavier O., (CPT) (M82) (Omar) U.S. Army PEP England, PSC 36, Box 397, APO AE 09456. S: Julia. Dy: Exchange Officer-United Kingdom Rtg: SAAIP. RW/Qual. Time: 2,000 Hrs.

Gardner, Jeffrey A., (1LT) (M95) B Co, 1-501st Avn Regt, Unit 15211, Box 68, APO AP 96271-0142. S: Tamara. Dy: Plt Ldr, Camp Humphreys, Korea. RW Qual. Time: 300 Hrs.

Garrett, James R., (CPT) (M92) (Jim) 207 Pinto Drive, Coppas Cove, TX 76522-1062. Dy: (817) 288-1015. Res: (817) 547-0722. Dy: S-2, 4-227th Avn. RW Qual. Time: 500 Hrs. Life Member.

Gass, Jonathan O., (CPT) (M92) HQS, 2-6 Cavalry, CMR 416, Box 80, APO AE 09140. S: Rachel. Dy: Squadron S-4, Illseheim, Germany. RW Qual. Time: 500 Hrs. Vp, Programs, Tators Chapter.

Gautreaux, Jay P., (CPT) (M91) 2306 Dickens Drive, Killeen, TX 76543-2757. Dy: (817) 287-0211. Res: (817) 699-1697. S: Susan. Dy: Adjutant, HHC, 2-58th Avn Regt (ATS), Fort Hood, TX. RW Qual. Time: 250 Hrs.

Gauval, Marc L., (CPT) (M92) P.O. Box 72923, Fort Bragg, NC 28307-2923. Dy: (910) 396-2582. Res: (910) 822-5763. S: Yang Hui. Dy: Assistant S-3, 3-229. Rtg: IP. RW Qual. Time: 1,525 Hrs.

Gawkins, Michael J., (CPT) (M88) (Mike) 804 Chancery Lane, Clarksville, TN 37042. Res: (615) 431-3182. S: Jo-Ann. RW Qual. Time: 1,600 Hrs./Cbt 160 AM/2.

Gaylor, William K., (CPT) (M91) (Bill) C Co, 2-227 Avn. Regt., Unit 20195, Box 1619, APO AE 09165. Res: (334) 598-3048. S: Michele. Dy: Company Commander, Hanau, Germany. RW Qual. Time: 1,450 Hrs./Cbt 25 AM/1.

Geis, John J., (CPT) (M90) 799 Donnell Boulevard, The Oaks, Apt. 29, Daleville, AL 36322. Dy: (334) 255-3344. Res: (334) 598-5226. Dy: AVOAC Student, Fort Rucker, AL.

Getztyl, Ray D., (CPT) (M87) P.O. Box 890, Rosepine, LA 70659-0890. Dy: (318) 531-9604. Res: (318) 463-8555. S: Linda. Dy: Observer/Controller, HQ JRTC. RW Qual. Time: 1,300 Hrs. Past Chapter Officer.

George, David A., (CPT) (M91) 92 Blackhawk Drive, Daleville, AL 36322. Dy: (334) 255-3344. Res: (334) 503-9251. Dy: Avn Officer, Adv Course Student, Fort Rucker, AL. Rtg: AA. RW Qual. Time: 349 Hrs.

George, Raymond E., (1LT) (M91) P.O. Box 414, Calcium, NY 13616. Dy: (315) 772-2186. Res: (315) 788-0824. Dy: Asst Bde S-4, 10th Avn Bde, Fort Drum, NY. RW Qual. Time: 310 Hrs.

Gibbs, Charles A., (1LT) (M94) (Chuck) 323 Sterling Creek Drive, Richmond Hill, GA 31324. Dy: (912) 767-7946. Res: (912) 756-2426. Dy: Platoon Leader, 2nd Squadron, 4th U.S. Cavalry. RW Qual. Time: 300 Hrs.

Gibson, Ann A., (1LT) (M92) C Co, 6/159 Aviation, CMR 408, Box 816, APO AE 09182. Dy: Battalion Asst S-3, Giebelstadt, Germany.

Giles, Carl L., (CPT) (M87) 3802 Rolling Pines Road, Enterprise, AL 36330. Dy: (334) 255-2618. Res: (334) 347-3813. S: Monica. Dy: 2-229th AHR. Rtg: AA. Time: 1,300 Hrs. AM/1.

Gill, Clair A., (2LT) (M94) 2840 Quail Cove, Enterprise, AL 36330. Res: (334) 347-4306. Dy: CBC & Flight School. Time: 110 Hrs.

Gist, Nicholas H., (2LT) (M94) (Nick) 104 Wildwood Drive, Enterprise, AL 36330. Res: (334) 347-6559. Dy: D Co, 1-145th Avn Regt. Time: 80 Hrs.

Glang, Frank O., (CPT) (M85) 218 Pine Mountain Road, Clarksville, TN 37042. Dy: (502) 798-5520. Res: (615) 551-3227. S: Heather. Dy: Company Commander, A Co, 8/101st Avn Regt, Fort Campbell, KY. Rtg: SAA MTP. RW

Qual. Time: 1,060 Hrs.

Glen, Lisa S., (CPT) (M86) 2805 Warbler Place, Williamsburg VA 23185. Dy: (804) 878-6804. Res: (804) 229-0065. S: Andy. Dy: Chief, Support Operations Div, USAUSA, Fort Eustis, VA. Rtg: MTP. RW Qual. Time: 670 Hrs. Past Chapter Officer.

Glover, Gregory W., (CPT) (M89) (Greg) 3009 Veterans Avenue, Coppas Cove, TX 76522. Res: (817) 542-7378. S: Molly. Dy: G3 Air, HQ, 2d Armored Division, Fort Hood, TX. Rtg: AA. RW Qual. PW Qual. Time: 650 Hrs. Life Member.

Godfrey, Daniel A., (CPT) (M86) (Dan) 2718 Etta Kay, Kempner, TX 76539. S: Janice. Dy: XO, 15th MI Bn, Fort Hood, TX. Rtg: AA. RW Qual. PW Qual. Time: 1,100 Hrs.

Goertemiller, John K., (1LT) (M93) (Kevin) 135 W. Concord Drive, Apt. F, Clarksville, TN 37042. Dy: (502) 798-6543. Res: (615) 645-2399. Dy: 2-101 Avn, Fort Campbell, KY. RW Qual. Time: 370 Hrs.

Goldenberg, Richard L., (CPT) (M89) 31 Nomis Avenue, Carthage, NY 13619. Dy: (315) 493-7207. S: Kelly. Dy: Flight Ops Officer, 3-17 Cavalry, Fort Drum, Rtg: AA. RW Qual. PW Qual. Time: 500 Hrs.

Goll, Daniel J., (CPT) (M91) 103 Arapaho Court, Enterprise, AL 36330. Dy: (334) 255-3344. Res: (334) 393-3493. S: Kim. Dy: A/1-145th Avn Regt AVOAC, Fort Rucker, AL. RW Qual. Time: 800 Hrs.

Gonzalez, Edward, (1LT) (M91) (Ed) 11137 Volare Drive, El Paso, TX 79936-1837. Dy: (915) 568-8278. Res: (915) 590-5754. S: Dianne. Dy: Asst S-4, HHT, 4/3 ACR. RW Qual. Time: 390 Hrs.

Gorak, Mark S., (1LT) (M91) 5008 Fisher Avenue, Fort Hood, TX 76544. Dy: (817) 539-3552. S: Kristin. Dy: Squadron Adjutant. RW Qual. PW Qual. Time: 850 Hrs.

Graham, Jeffery A., (CPT) (M83) (Jeff) HHC, 2-501st Avn Regt, Unit 15188, APO AP 96271-0124. S: Kimberly. Dy: Bn S-3, Camp Humphreys, Korea. Rtg: AA. RW Qual. Time: 1,000 Hrs. AM/1.

Gray, Michael G., (1LT) (M88) 1-82nd (AB) Avn Bn, Fort Bragg, NC 28307. Dy: (404) 938-2304. S: Christa. Dy: 1-82nd (AB) Avn Bn, Fort Bragg, NC. RW Qual. Time: 1,200 Hrs. Past Chapter Officer.

Griffin, Dennis E., (CPT) (M92) 6-6 Cavalry, CMR 416, Box 478, APO AE 09140. S: Michele. Dy: 6/6 Cav, Illseheim, Germany. RW Qual. Time: 405 Hrs.

Grigsby, Robert E., (CPT) (M89) (Rob) 1103 Rosebrook Drive, Clarksville, TN 37042. Dy: (502) 798-6318. Res: (615) 645-5927. S: Michele. Dy: Commander, A Troop, 2/17 Cavalry, Fort Campbell, KY. Rtg: AA. RW Qual. Time: 650 Hrs./Cbt 32 AM/1 V.

Grinsell, Christian B., (CPT) (M88) (Chris) 841 Smith Branch Road, Clarksville, TN 37042. Dy: (502) 798-7933. Res: (615) 326-5338. S: Laurie. Dy: Asst S-3, 101st Avn Bde, Rtg: AA. RW Qual. Time: 715 Hrs./Cbt 50 AM/2.

Gronbeck, Paul D., (CPT) (M90) CMR 3, Box 7452, Fort Rucker, AL 36362. Res: (334) 598-5216. Dy: AH-64 Qualification Course, Fort Rucker, AL. Rtg: AA. RW Qual. Time: 650 Hrs. Life Member. Past Chapter Officer.

Gusukuma, Danny T., (2LT) (M94) 380 Tar Hill Road, No. 8, Daleville, AL 36322. Dy: (334) 255-9961. Res: (334) 503-9838. Dy: D Co, 1/145th Avn.

HHHHHHHHHH

Hadot, Thomas J., (CPT) (M93) (Tom) C Co, 6/6 Cavalry, CMR 416, Box 460, APO AE

09140. S. Stacy. Dy: Troop Commander, Beshlem, Germany. RW Qual. Time: 1,000 Hrs.

Hadley, Michael R., (CPT) (M95) (Buzz) 100 Camelot Crescent, York County, VA 23604. Dy: (804) 878-5301. S. Mary. Dy: Cdr, 1st S & F.

Haidler, Michael K., (CPT) (M89) (Mike) 218 Elder Way, Daleville, AL 36322. Dy: (502) 795-8168. Res: (334) 503-9475. S. Paula. Dy: Experimental Test Pilot, ATTC, Fort Rucker, AL. Rtg: SAA MTP. RW Qual. FW Qual. Time: 2,300 Hrs./Cbt 8 AM/1.

Haines, Darwin L., (CPT) (M89) 3365 E Rhett Butler Rd., Clarksville, TN 37042. Dy: (502) 798-1867. Res: (615) 645-6517. S. Paula. Dy: A Company, 1/160th SOAR (A), Fort Campbell, KY. RW Qual. FW Qual. Time: 1,200 Hrs. Past Chapter Officer.

Hales, Michael A., (2LT) (M94) 10 Castle Lane, Fort Rucker, AL 36382. Res: (334) 598-4510. S. Marci. Dy: AVOBC Student.

Hall, Eric R., (1LT) (M94) 8360-A Dunham Court, Springfield, VA 22152. Dy: (703) 806-7234. Res: (703) 451-3483. Dy: OSAC S2 Davison Army Airfield. RW Qual. Time: 450 Hrs.

Halloran, Jason M., (1LT) (M92) (Gij Jay) A Co, 4228th Avn Regt, APO AA 34042. Dy: Soto Cano AB, Honduras. RW Qual. Time: 500 Hrs.

Hamilton, Warren D., (2LT) (M94) 3312 Shepard Avenue, No. 46, El Paso, TX 79904. Res: (915) 565-5494. RW Qual. Time: 200 Hrs.

Hamm, Michael W., (CPT) (M88) (Mike) 4105-B Quarters, Quantico, VA 22134. Res: (703) 441-6344. S. Army. Dy: Amphibious Warfare School, Quantico, VA. Rtg: AA. RW Qual. Time: 1,000 Hrs.

Hamontree, George S., (CPT) (M92) (Sam) 2101 Beretta Drive, Killeen, TX 76543-2691. Dy: (817) 288-3468. Res: (817) 690-0012. Dy: CATB, Fort Hood. Rtg: AA MTP. RW Qual. Time: 210 Hrs. Life Member.

Hannah, Mark W., (CPT) (M89) 1002 Yuma Street, Belle Fourche, SD 57717. S. Amber. RW Qual. Time: 838 Hrs./Cbt 70 AM/2.

Hansen, John T., (CPT) (M84) (JT) 941 K Cheyenne Curve, Leavenworth, KS 66048. Dy: (915) 651-3135. S. Jeannant. Rtg: SAA. RW Qual. Time: 2,000 Hrs.

Hansen, Michael P., (1LT) (M83) (Spanky) A Troop, 8-6 Cavalry, CMR 416, Box 39, APO AE 09140. S. Carolann. Dy: Platoon Leader. RW Qual. Time: 850 Hrs./Cbt 20

Hansen, Michael C., (CPT) (M89) (Mike) HHC, 2-2 Avn Regt, Unit 15427, APO AF 96257-0460. S. Daroy. Dy: Bn S-1, 2-2 Avn Regt. RW Qual. Time: 750 Hrs./Cbt 35 AM/3.

Hanson, Douglas D., (2LT) (M93) (Doug) 2532 Old Russellville Pk, No. 4, Clarksville, TN 37040. Res: (615) 572-0800. S. Heidi. Dy: Asst S-1, 2-101st Avn Regt, Fort Campbell, KY. RW Qual. Time: 250 Hrs.

Hardee, William C., (CPT) (M94) (Craig) 302 Janice Street, Enterprise, AL 36330-3418. Dy: (334) 255-8424. S. Beth. Dy: S1, 1-223rd Avn Rgt. IP. RW Qual. Time: 1,050 Hrs./Cbt 30 AM/1.

Harrison, Jon M., (CPT) (M89) 739 Gardenale Lane, Clarksville, TN 37040-5629. Res: (615) 647-5189. S. Linda. Dy: D Co, 5/101st Avn Bn. RW Qual. Time: 850 Hrs.

Hart, George J., (CPT) (M94) 3813 Rolling Pines Drive, Enterprise, AL 36330. Dy: (334) 255-5051. Res: (334) 393-0074. S. Sharon. Dy: Cdr, C Co, 1/14th Avn Regt. Rtg: SAA I.P. RW Qual. Time: 1,500 Hrs./Cbt 75 AM/2.

Hart, Wendy L., (1LT) (M93) 101 S. George Boulevard, Apt. 61, Savannah, GA 31419. Dy: (912) 767-5538. Res: (912) 925-5412. S. Dan-

iel. Dy: HHC, 24 ID Asst G3 AIR, Fort Stewart, GA. RW Qual. Time: 750 Hrs.

Hartzog, Byron K., (1LT) (M93) (BK) HHC, 2227th Aviation, Unit 20195, Box 1753, APO AE 09165. S. Katrina. Dy: XO. RW Qual. Time: 400 Hrs.

Hastings, Robert T., (CPT) (M91) (Bob) HQ, V Corps, PAO, CMR 420, Box 2017, APO AE 09063. S. Leigh. Dy: Deputy Public Affairs Officer, Heidelberg, Germany. Rtg: MAA. RW Qual. Time: 2,010 Hrs.

Hastings, Roy W., (2LT) (M93) (Rob) 402 Tower Street, Killeen, TX 76541. Dy: (817) 288-3511. Res: (817) 526-2835. S. Kimberley. Dy: IIIV Platoon Leader, 3/4 Cavalry, Fort Hood, TX. RW Qual. Time: 250 Hrs.

Hau, Roland C., (CPT) (M85) (Goidie) A Co, 5-159th Avn Regt, Unit 26444, APO AE 09182. S. Anji. Dy: Giebelstadt, Germany. Rtg: AA TP MTP. RW Qual. Time: 1,050 Hrs.

Haws, Randall L., (CPT) (M90) (Randy) A Co, 3-227th Avn Regt, Unit 20196, Box 35, APO AE 09165. S. Jana. Dy: Company Commander, Hanau, Germany. RW Qual. Time: 600 Hrs.

Hayman, Jeffrey W., (CPT) (M85) (Jeff) 5465 South Bucksian Pass, Colorado Springs, CO 80917. Dy: (719) 554-4540. RW Qual. FW Qual. Time: 1,500 Hrs.

Heffernan, Kelly A., (CPT) (M91) 3616 Hastings Drive, Fayetteville, NC 28311. Dy: (910) 422-7755. Res: (910) 630-1444. Dy: 82nd Avn Bde, Fort Bragg, NC. RW Qual. Time: 500 Hrs.

Hein, Robert F., (CPT) (M91) (Bob) PSC 1, Box 4340, APO AA 34001. S. Leah. Dy: Executive Officer, SOUTHCOMJ-1, Republic of Panama. RW Qual. Time: 701 Hrs./Cbt 49

Heikman, Dean D., (CPT) (M90) (Dean) 1963 Steford Drive, Clarksville, TN 37043. Dy: (502) 798-1858. Res: (615) 648-1767. Dy: D Co, 1/160th Special Operation Aviation Regt, Fort Campbell, KY. Rtg: SAA MTP. RW Qual. Time: 1,110 Hrs./Cbt 112 AM/1.

Heller, John J., (CPT) (M86) Black Knights Chap Sr, VP, 3042-B Meigs Place, West Point, NY 10996. Dy: (914) 938-3044. Res: (914) 446-7347. S. Tracy. Dy: Professor, USMA, West Point, Rtg: AA. Time: 700 Hrs. Senior Vice President, Black Knights Chapter.

Helsel, Bryan S., (2LT) (M94) 145 Woodfield Place, Enterprise, AL 36330. Dy: (334) 255-3311. Res: (334) 393-7905. Dy: Flight School, D Co, 1-145 Avn.

Henderson, Joseph P., (CPT) (M93) (Joe) 739 Peterson Lane, Maryville, TN 37801. Dy: (615) 983-2448. S. Kye Hwa. Dy: Graduate Student, Univ. of Tennessee. RW Qual. FW Qual. Time: 1,100 Hrs.

Hendrickson, Heather G., (CPT) (M88) 508 Cambridge Drive, Enterprise, AL 36330. Dy: (334) 255-2672. Res: (334) 347-9012. S. David. Dy: Operations Research Systems Analyst, DCD, Fort Rucker, AL. Rtg: AA. RW Qual. Time: 800 Hrs.

Heneghan, Jeremiah S., (CPT) (M91) (Jerry) C Co, 5-501st Avn Regt, Box 27, APO AF 96297. Dy: Co Cdr. RW Qual. Time: 425 Hrs.

Hennessey, Scott P., (2LT) (M95) 217 Apache Drive, Apt. 23-7, Enterprise, AL 36330. Dy: (334) 255-3311. Res: (334) 347-7979. Dy: D Co, 1/145th Avn. Time: 60 Hrs.

Henry, Todd M., (CPT) (M93) A Co, 7-1 Avn, CMR 454, Box 2504, APO AE 09250. S. Donna. Dy: Cdr, A Co, 7-1 Avn. RW Qual. Time: 650 Hrs.

Heppelman, Andrew, (CPT) (M95) (Andy) 508 Woodvale Drive, Hopkinsville, KY 42240. Dy: (502) 798-2772. Res: (502) 887-9216. Dy: C/1-58th Avn, Fort Campbell, KY. RW Qual. FW Qual. Time: 1,200 Hrs.

Hernandez, Jose D., (CPT) (M91) (Joe) A Co,

3rd MI Bn (AE), Unit 15220, Box 121, APO AF 96271-0156. S. Marissa. Dy: C and E Platoon Leader, A Co, 3rd MI Bn (AE), 501st MI Bde, Korea. RW Qual. FW Qual. Time: 700 Hrs.

Hershey, Neil S., (CPT) (M92) CMR 430, Box 927, APO AE 09096-4310. Dy: 1st MI Bn (AE), Wiesbaden, Germany. RW Qual. FW Qual. Time: 700 Hrs.

Hershman, David R., (CPT) (M93) 450 Belmont Road, Clarksville, TN 37040-7726. Dy: (502) 798-4384. Res: (615) 503-1656. S. Jennifer. Dy: Plt Ldr, Fort Campbell, KY. RW Qual. FW Qual. Time: 950 Hrs.

Hesse, Robert L., (CPT) (M91) 710 Delphi Drive, Duncanville, TX 75137-3617. Dy: (214) 263-8741. Res: (214) 709-6266. S. Kathy. Dy: Aviation Readiness Group, Fifth U.S. Army. Rtg: SAA. RW Qual. Time: 1,200 Hrs.

Hill, Eric T., (1LT) (M92) 45th Medical Company (AA), CMR 454, Box 2554, APO AE 09250. S. Lisa. Dy: Ad, 45th Medical Co, Ansbach Army Airfield, Katterbach, Germany. RW Qual. Time: 1,400 Hrs.

Hinck, John M., (CPT) (M91) P.O. Box 72230, Fort Bragg, NC 28307-4230. Dy: (919) 396-5541. Res: (919) 822-3591. Dy: HHC, 3-229th Avn (Atk), RW Qual. Time: 600 Hrs.

Hinkle, Burl S., (1LT) (M92) 1427-A Werner Park, Fort Campbell, KY 42223-1118. Dy: (502) 798-3272. Res: (615) 431-7748. S. Tara. Dy: A4, 6/101st Avn Bn Div (AA). RW Qual. Time: 425 Hrs.

Hoover, Bradley A., (CPT) (M93) (Brad) 4108 Vicki Drive, Killeen, TX 76542-7851. Dy: (817) 288-6147. Res: (817) 699-2238. S. Donna. Dy: HHC/1-502 Avn (Atk), RW Qual. Time: 320 Hrs.

Hodgman, Robert J., (CPT) (M92) (Rob) 2033A Werner Park, Fort Campbell, KY 42223-1164. Dy: (502) 798-7236. Res: (615) 431-6772. S. Diana. Dy: C Company, 7-101st Avn Regt, Fort Campbell, KY. RW Qual. Time: 600 Hrs.

Hoecherl, Joseph A., (1LT) (M93) (Joe) HHC, 1-2 Avn Regt, Unit 15420, Box 1089, APO AF 96224. S. Kelly. Dy: Asst S-3, Operations, Camp Mobbie, Korea. RW Qual. Time: 200 Hrs.

Hoelz, Nicholas J., (1LT) (M92) (Nick) A Troop, 6-6 Cav, CMR 416, Box 595, APO AE 09140. Dy: Plt Ldr. RW Qual. Time: 600 Hrs.

Hollister, Linda S., (1LT) (M92) 1206 Werner Park, Apt. 4, Fort Campbell, KY 42223-1123. Dy: (502) 798-4738. Res: (615) 431-7621. S. Carl. Dy: EH-60 Plt Ldr, B Co, 6-101st Avn. RW Qual. Time: 350 Hrs.

Holm, John D., (CPT) (M94) (Jaf) 45th Med Co (AA), CMR 454, Box 2551, APO AE 09250. S. Johnna. Dy: Medevac Plt, Katterbach, Germany (Ansbach). Rtg: AA MTP. RW Qual. FW Qual. Time: 750 Hrs.

Hoskyn, John M., (1LT) (M92) (Mark) A Co, 3-227th Avn, Unit 20196, Box 660, APO AE 09165. Dy: Attack Platoon Leader, Hanau, Germany. RW Qual. Time: 500 Hrs.

Hottel, Kevin D., (CPT) (M89) 65 Diamond Avenue, Fort Rucker, AL 36362. Dy: (334) 255-1020. Res: (334) 503-9064. S. Gayle. Dy: A Co, 1-145th Avn, Fort Rucker, AL. RW Qual. Time: 1,200 Hrs.

Howard, Paul D., (CPT) (M91) Box 198, Route 1, Registar, GA 30452. Res: (502) 351-0737. Dy: Armor Officer Advanced Course, Fort Knox, KY. RW Qual. Time: 570 Hrs.

Hubbard, Jerry D., (CPT) (M91) 2426 Chester Harris Road, Woodlawn, TN 37191. Res: (615) 326-9274. Dy: ATK LNO. RW Qual. Time: 520 Hrs.

Huff, William H., (1LT) (M95) (Bill) 11 Harris Drive, Fort Rucker, AL 36362. Dy: (334) 255-9961. Res: (334) 588-8301. S. Michelle. Dy: Student, Fort Rucker, AL. Time: 60 Hrs.

Huggins, Ronald V., (CPT) (M94) P.O. Box 1711, Kileen, TX 75541. RW Qual. Time: 500 Hrs.

Hunnicut, Jack C., (2LT) (M94) 109 Cahaba Drive, Enterprise, AL 36330. Res: (334) 347-1629. Dy: D Co, 1/145th Avn.

Hunt, Robert J., (CPT) (M95) (Rob) 1174 Rue La Chelle Lane, Creve Coeur, MO 63141. Dy: (314) 263-9705. Res: (314) 275-9910. S: Margaret. Dy: XO, PEO Comanche, St. Louis, MO. RW Qual. Time: 700 Hrs./Cbt 30 AM/1.

Hyder, Lee D., (1LT) (M91) 2823 Hinson Road, Woodawn, TN 37191. Res: (615) 648-9021. Dy: A Co, 7-101st Avn. RW Qual. Time: 475 Hrs.



loos, Steven P., (CPT) (M88) (Steve) 1783 Broadripple Drive, Clarksville, TN 37042. Dy: (615) 798-7514. Res: (615) 647-9772. S: Katherine. Dy: B Co, 7/101st Avn Regt, Fort Campbell, KY. Rtg AA. RW Qual. Time: 900 Hrs./Cbt 65 AM/1.

hwanski, Lawrence M., (CPT) (M88) (Larry) 162 Belle Grove Drive, Richmond Hill, GA 31324. Dy: (912) 352-6118. Res: (912) 756-2884. Dy: PC Officer, F Co, 924th SB (A). Rtg AA MTP. RW Qual. Time: 900 Hrs./Cbt 150 AM/1. Past Chapter Officer.



Jackson, Randy K., (CPT) (M87) 30 Full Sweep Drive, Savannah, GA 31419. Dy: (912) 352-6906. Res: (912) 920-2591. Dy: Platoon Leader, A Co, 3/160th SOAR (A). RW Qual. Time: 1,300 Hrs.

Jackson, Robin L., (CPT) (M87) P.O. Box 1317, Fort Belvoir, VA 22060. Dy: (703) 806-7234. Res: (703) 730-5832. Dy: OSAC, DAAF. Rtg AA. RW Qual. FW Qual. Time: 1,200 Hrs. Life Member.

James, Gregory K., (CPT) (M89) (Greg) B Co, 4-58th Avn Regt, Unit 15348, APO AP 96258-0197. Dy: Commander. RW Qual. Time: 650 Hrs./Cbt 2.

James, Jack A., (1LT) (M82) (J.A.) 721-A Vough Avenue, Wahiaua, HI 96786. Dy: (808) 656-5840. Res: (808) 624-5493. S: Annette. Dy: Aik Plt Ldr. Rtg AA. RW Qual. Time: 375 Hrs.

Janosik, Gregory J., (CPT) (M89) (Greg) 501 Mt Side, APO AP 96205. Dy: 3rd Mt Bn (AE), Korea. Rtg SAA. RW Qual. FW Qual. Time: 1,600 Hrs./Cbt 27 AM/1.

Jenkins, Harold A., (2LT) (M93) 342 Confer Drive, Fayetteville, NC 28314. S: Khadija. RW Qual. Time: 195 Hrs.

Jentoff, Heidi A., (1LT) (M91) Route 4, Box 3011-D, Ozark, AL 36380. Dy: (334) 255-4740. Res: (334) 445-0367. Dy: S-4, 1-212th Avn, Fort Rucker, AL. Rtg IP. RW Qual. Time: 1,000 Hrs.

Jepson, Jeffrey F., (CPT) (M91) 21 E. 50th Street, Savannah, GA 31405-2142. Dy: (912) 234-0078. Res: (912) 927-3018. Dy: HHC, 4-24 Avn Regt, HAAF, GA.

Jefer, William G., (1LT) (M95) (Gary) 42 Fabian Lane, Hinesville, GA 31313. Dy: (912) 353-2515. Res: (912) 876-6204. S: Kara. Dy: Plt Ldr, HHC, 1-24th Avn Regt, RW Qual. Time: 385 Hrs.

Johnson, Carter A., (CPT) (M91) (C.A.) 150 Lakeview Drive, Daleville, AL 36322. Dy: (334) 255-2056. Res: (334) 598-8349. S: Stacy. Dy: ASS, 2/229th ATGHR. RW Qual. Time: 450 Hrs.

Johnson, Dale N., (CPT) (M88) 1014 232nd Place S.W., Bothell, WA 98021. Res: (209) 486-1648. S: Valerie. Dy: University of Wash-

ington/Advance Civil Schooling, School of Law. Rtg AA. RW Qual. Time: 850 Hrs.

Johnson, Eric S., (CPT) (M89) 106 Harrant Creek Drive, Enterprise, AL 36330. Dy: (334) 255-2180. Res: (334) 393-9462. S: Sandra. Dy: Asst TSM, Comanche, Fort Rucker, AL. RW Qual. Time: 1,400 Hrs./Cbt 182 AM/1.

Johnson, Robert B., (CPT) (M93) (Byran) 3400 Salado Creek Drive, No. 708, San Antonio, TX 78217. S: Mona. RW Qual. Time: 500 Hrs.

Johnson, Robert J., (CPT) (M92) (Rob) 417 Tornahawk Drive, Harker Heights, TX 78543-2055. S: Janice. Rtg AA. IP. RW Qual. Time: 1,500 Hrs./Cbt 25 DFC/1.

Jones, Barry L., (CPT) (M94) 94-127 Puanane Loop, Millan, HI 96780. Dy: (808) 656-2551. Res: (808) 623-9460. S: Keanna. Dy: D Co, 4-25th Avn Regt, Wheeler Army Airfield, HI. RW Qual. Time: 870 Hrs./Cbt 28.

Jones, Monroe C., (CPT) (M91) (Marly) B Co, 7-1 Avn, CMR 454, Box 2019, APO AE 09250. S: Leslie. Dy: Company Commander, Rtg AA. RW Qual. Time: 550 Hrs.

Jones, Ryan S., (CPT) (M90) 603 Zinnia Drive, Clarksville, TN 37042. Dy: (502) 798-4020. Res: (615) 647-9392. Dy: HHC, 9/101st Avn, Asst SS. RW Qual. Time: 780 Hrs.

Juergens, Richard A., (CPT) (M92) (Rich) 3300 N. Henderson Way, Clarksville, TN 37042-5672. Dy: (502) 798-1704. Res: (615) 645-3357. S: Diana. Dy: B Co, 2-160th Special Operations Aviation Regt (A), Fort Campbell, KY. Past Chapter Officer.

Jurus, Michael H., (CPT) (M92) 707 Old Mill Road, Savannah, GA 31419. Dy: (912) 352-5114. Res: (912) 920-1533. S: Tammy. Dy: HHC, 24th Avn. Bde. RW Qual. Time: 1,300 Hrs.



Kaempfer, Eric W., (CPT) (M83) 7843 Horse-shoe Trail, Huntsville, AL 35802. Res: (205) 881-6496. S: Karyn. Dy: Student, University of Indiana. Rtg AA. RW Qual. Time: 800 Hrs./Cbt 35 AM/1.

Kall, Joseph J., (CPT) (M91) (Joe) 207th Aviation Company, Unit 29231, Box 08, APO AE 91012. Dy: 207th Avn Co., FH Ops, Heidelberg, Germany. RW Qual. FW Qual. Time: 2,100 Hrs.

Kanicki, James G., (CPT) (M94) (Nate) 409B Gordon Road, Wahiaua, HI 96786-3813. Dy: (808) 656-2556. Res: (808) 624-6072. S: Teri. Dy: Asst SS, HHC, 4/25th Avn Regt, RW Qual. Time: 620 Hrs.

Kankel, Karl D., (1LT) (M94) 1001 Twin Creek Drive, No. 1210, Kileen, TX 75543. Dy: (817) 287-9936. Res: (817) 699-4894. Dy: Asst S-3, HHT, 1-6 Cav, 6th Cav Bde (AC). RW Qual. FW Qual. Time: 850 Hrs.

Karkins, T.J., (CPT) (M91) (T.J.) Pikes Peak Chap. Treasurer, 2506 Parkview Boulevard, Colorado Springs, CO 80906-1162. Dy: (719) 526-2568. Res: (719) 578-5415. Dy: Avn. Commander, Officer, 4th Avn. Brigade, C Troop, 1-10 Cav Regt, RW Qual. Time: 750 Hrs. Treasurer, Pikes Peak Chapter.

Kaufmann, Andrew J., (CPT) (M91) (Turle) 71 A.M. Windham Drive, No. 502, Daleville, AL 36322. S: Robin. Dy: 4/24CR, Fort Bragg, NC. RW Qual. FW Qual. Time: 800 Hrs.

Keeter, Robert R., (2LT) (M93) (Robb) 5345 Pleasant Place, Fayetteville, NC 28311. Dy: (910) 396-4343. Res: (910) 630-6552. Dy: Quik Fix (EH00A) Platoon Leader, 82d Abn Div, Fort Bragg, NC. RW Qual. Time: 220 Hrs.

Kellar, Ronald L., (CPT) (M83) (Ron) RR 3, Box 280, Enterprise, AL 36330. S: Susan. Dy:

AP64 AQC. RW Qual. Time: 700 Hrs. Past Chapter Officer.

Keller, Paul F., (CPT) (M87) HHC, 4th Bde, 3rd ID, CMR 454, Box 2519, APO AE 09250. S: Miami. Dy: Company Commander, Rtg AA MTP. RW Qual. Time: 500 Hrs. AM/1.

Kelley, Jr, Danny M., (2LT) (M93) (Dann) 2250 Westchester Drive, Apt. 8, Manhattan, KS 66502. Res: (913) 537-1314. S: Jennifer. Dy: TARP Platoon Leader, A Co, 4-1 Avn, 4th Bde, 1st ID (M). RW Qual. Time: 245 Hrs.

Kellogg, Michael S., (2LT) (M90) (Mike) A Co, 2/227th Avn, Unit 20195, Box 1701, APO AE 09165. S: Kelly. Dy: Apache Plt Ldr. Rtg AA. RW Qual. Time: 775 Hrs.

Kennedy, Joshua S., (2LT) (M94) (Josh) 507 Briarwood Drive, Apt. 11D, Enterprise, AL 36330. Dy: (334) 255-9961. Res: (334) 393-2112. S: Kristen. Dy: D Co, 1/145th Avn. RW Qual. Time: 175 Hrs.

Kennedy, Matthew J., (CPT) (M94) (Matt) 190 Lakeview Drive, Daleville, AL 36322. Dy: (334) 255-3344. Res: (334) 503-9025. S: Kart. Dy: Student, Aviation Officer/Advanced Course, Fort Rucker, AL. Rtg AA. RW Qual. Time: 425 Hrs.

Kenney, Christopher, (CPT) (M88) 914 Erwin Court, Fort Winthrop, AK 99703. Dy: (907) 353-7260. Res: (907) 356-3456. S: Tillary. Dy: Flight/Platoon Leader, Fort Winthrop, AK. Rtg AA. IFE. RW Qual. Time: 732 Hrs.

Kimbrogh, Robert S., (CPT) (M89) (Shane) 114 Duncan Court, Southern Pines, NC 28387. Dy: (910) 396-8597. Res: (910) 692-0897. S: Robbie. Dy: Company Commander, A Co, 1-229th ATGHR. RW Qual. Time: 680 Hrs./Cbt 30.

Kinder, Mary B., (CPT) (M94) 132 Woodfield Place, Enterprise, AL 36330. Dy: (334) 255-9073. Res: (334) 347-1752. Dy: 1-145th Avn.

King, Michael E., (CPT) (M94) 4341 Decatur Drive, Woodbridge, VA 22193. Dy: (703) 706-1200. Res: (703) 876-6897. S: Linda. Dy: HQ INSCOM, Fort Belvoir, VA. RW Qual. FW Qual. Time: 1,500 Hrs.

King, Steven A., (CPT) (M93) (The Heat) HHC Avn Bde 210, Unit 15435, APO AP 96257. Dy: (205) 526-2691. Res: (719) 536-9289. Dy: Assistant S-3, Aviation Bde 210, Rtg SAA. RW Qual. Time: 1,150 Hrs./Cbt 20 AM/1.

Kirkland, David W., (CPT) (M89) Iron Mike Chap. Treas., 121 Sissler Street, Fort Bragg, NC 28307. Dy: (910) 396-1012. Res: (910) 868-8618. S: Robin. Dy: Company Commander, HHC 1-58th Avn (Airborne), Fort Bragg, NC. RW Qual. Time: 800 Hrs. Treasurer, Iron Mike Chapter.

Klaus, Jay F., (CPT) (M94) 207 Redan Drive, Savannah, GA 31410. Dy: (912) 352-6259. Res: (912) 898-8854. S: Rebecca. Dy: Asst S-3, Hunter Army Airfield, GA. RW Qual. Time: 975 Hrs./Cbt 263.

Klump, Joseph J., (CPT) (P) (M94) (Joe) 8150 Buck Drive, Cedar Hill, MO 63016. Dy: (314) 263-5514. Res: (314) 274-8833. S: Karen. Dy: AFM Communications. RW Qual. Time: 1,000 Hrs./Cbt 20 AM/2.

Knapp, James B., (CPT) (M88) (Jimmy) 78th Avn Bn, Unit 45007, Box 54, APO AP 96343-0084. Dy: Company Commander, U.S. Army, Japan. Rtg AA. RW Qual. Time: 1,100 Hrs./Cbt 50 AM/2.

Koellzow, Sheryl M., (CPT) (M91) 1946 NE Loop 410, No. 380, San Antonio, TX 78217. Res: (210) 930-2148. Dy: 377th Med Co, Korea. RW Qual. Time: 700 Hrs./Cbt 80.

Koenig, Steven T., (CPT) (M92) HSC 3rd Mt Bn, Unit 220, APO AP 96271. S: Cindy. Dy: S-4, 3d Military Intelligence Battalion, Camp

Humphreys, Korea, RW Qual. FW Qual. Time: 1,350 Hrs.

Kokosis, Gregory A., (CPT) (M85) (Koko) 7216 Old Lantern Way, Springfield, VA 22152. Dy: (703) 756-2162. S. Vicki. Dy: USA OFPTC, Alexandria, VA. Rtg: AA. Time: 700 Hrs.

Kools, Joseph M.J., (CPT) (M85) (Joe) 127 Waterford, Dothan, AL 36303. Dy: (334) 792-8475. Res: (334) 255-2342. S. Lori. Dy: SA. 24229th Ak Hel Regt. RW Qual. Time: 1,350 Hrs.

Kopra, Timothy L., (CPT) (M85) (Tim) 1308 Crestline Drive, Smyrna, GA 30080. Dy: (404) 432-5119. Res: (404) 432-5119. S. Dawn. Rtg: SAA. RW Qual. Time: 1,100 Hrs./Cbt 21 AM/1.

Korincsak, Donna K., (CPT) (M86) 2101 Hazeltine Lane, Austin, TX 78747. Res: (512) 282-8726. S. Richard. Dy: Graduate Student, Univ. Of Texas at Austin, USA Student Detachment. Rtg: SAA. RW Qual. Time: 1,000 Hrs.

Koucherav, Richard J., (CPT) (M90) (Rich) HHC DISCOM, 1st AD, CMR 438, Box 2398, APO AE 09111-2138. S. Angela. Dy: DMCC ASO EMMO, Rose Bks, Bad Kreuznach, Germany. Rtg: AA. RW Qual. Time: 900 Hrs.

Kraeling, William A., (1LT) (M93) (Bill) C Troop, 6-B Cavalry, CMR 416, Box 740, APO AE 09140. S. Kim. Dy: Platoon Leader, Illenheim, Germany. Rtg: AA. RW Qual. Time: 840 Hrs. Past Chapter Officer.

Kranhold, Keith J., (CPT) (M93) (Keith) 1309 Pickwick Place, Bloomington, IN 47401. Dy: (812) 855-3280. Res: (812) 339-6030. S. Rebecca. Dy: Student, Indiana University. 93 Avionics Award.

Kratz, George F., (CPT) (M92) (Fred) 728 Westoreck Drive, Clarksville, TN 37040. Dy: (502) 798-9514. Res: (615) 648-8335. S. Stephanie. Dy: 101st Airborne Division (AASLT), Fort Campbell, KY. Rtg: AA. RW Qual. Time: 499 Hrs.

Kreuscher, Richard F., (CPT) (M90) (Rich) 111 Hall Street, Daleville, AL 36322. Dy: (334) 255-3344. Res: (334) 503-9760. S. Gabi. Dy: Student - AVOAC. Rtg: IP. RW Qual.

Krump, Sandie J., (2LT) (M94) 200 Cheyenne Drive, No. 34, Enterprise, AL 36330. Res: (334) 347-4237. Dy: AD, D Co, 1/145th Avn.

Kubista, Todd A., (1LT) (M91) (Kubie) 1001 Twin Creek Drive, No. 406, Killeen, TX 76543. Dy: (817) 288-1223. Res: (817) 690-4110. S. Melissa. Dy: TARP, A Co, 4-227th Avn, Fort Hood, TX. RW Qual. FW Qual. T: 1,400 Hrs.

Kuch, Sharmar L., (CPT) (M85) (Sharm) 919 Shellie Drive, Clarksville, TN 37043-5565. Dy: (502) 798-5245. Res: (615) 647-4650. S. Kim. Dy: Co Cdr, D4-101 Avn Regt, Fort Campbell, KY. Rtg: SAA/MTP. RW Qual. Time: 1,700 Hrs.

Kucik, Paul D., (1LT) (M93) 137 N. Leeds Gate Road, Savannah, GA 31406. Dy: (912) 767-7911. Res: (912) 925-7402. S. Lisa. Dy: Assistant Secretary of General Staff, 24 ID. RW Qual. Time: 453 Hrs.

Kyriss, Marzen W., (CPT) (M93) (Mark) HHC, CMTC, CMR 414, Box 795, APO AE 09173. S. Julie. Dy: Aviation Observer Controller, Hohenfels, Germany. RW Qual. Time: 1,400 Hrs. Secretary, Bavarian Chapter.

LLLLLLLLL

Ladd, Keith D., (CPT) (M90) 7265 Guadalupe Circle, No. B, Fort Carson, CO 80913-2269. Dy: (719) 526-0445. Res: (719) 579-8681. S. Claudia. Dy: Aide de Camp to Commanding General, Fort Carson, CO. RW Qual. Time: 950 Hrs./Cbt 150 AM/1.

Laganelli, John F., (CPT) (M89) 5867 Wainwright Drive, Fort Hood, TX 76544-1336. Dy: (817) 287-2977. Res: (817) 539-5052. S. Dian.

Dy: Asst S3, 2-502 Avn Regt, Fort Hood, TX. Rtg: AA. RW Qual. Time: 950 Hrs./Cbt 67 AM/1, V. Past Chapter Officer.

Lane, John D., (2LT) (M94) 202 Wildwood Drive, Enterprise, AL 36330. Dy: (334) 255-3311. Res: (334) 347-8237. Dy: Flight School, Fort Rucker, AL.

Lankowicz, Andrew J., (CPT) (M89) (Spanky) 230th Medical Co (AA), Box 317, APO AE 09180-3460. S. Anita. Dy: AVUM Platoon Leader/Maintenance Officer, Rtg: AAMTP. RW Qual. Time: 1,000 Hrs.

Lanzl, John A., (CPT) (M92) 3417 Drake Road, Adams, TN 37010-9054. Dy: (502) 753-7093. Res: (615) 431-3571. S. Lori. Dy: P-C Officer, Rtg: MTP. RW Qual. Time: 850 Hrs./Cbt 35 AM/2.

Larsen, James E., (CPT) (M89) (Jay) 822 Briarwood Circle, Leesville, LA 71446. Dy: (318) 531-0208. Res: (318) 537-8440. S. Elizabeth. Dy: Sr Asst Observer/Controller, Avn Div, Ops Grp, JRTC. RW Qual. Time: 1,150 Hrs. Past Chapter Officer.

Larsen, Jon A., (CPT) (M84) 104 Rosford Avenue, White Sands Missal Rge, NM 88002. Dy: (505) 678-7033. Res: (505) 678-9931. S. Jennifer. Dy: Combat Operations Analyst, TRADOC Analysis Center. RW Qual. Time: 1,000 Hrs.

Larson, Ronik W., (CPT) (M88) B Co, 3/501st Avn Regt, Unit 15566, APO AF 96297-0625. Dy: Aviation Maintenance Officer, Korea. Rtg: AA. IP. RW Qual. Time: 1,700 Hrs.

Latham, William C., (CPT) (M89) (Bill) 115 Chalice Way, Savannah, GA 31419. Dy: (912) 767-1064. Res: (912) 920-3487. S. Cindy. Dy: ADAO, HHC, 24th Avn Bde. RW Qual. Time: 1,100 Hrs.

Latvala, Daniel W., (1LT) (M91) (Dan) Old Bill Chapter VP Memb. 5251 B McNeil South, Fort Bliss, TX 79906. Dy: (915) 568-8278. Res: (915) 562-9806. S. Jacki. Dy: Asst S-4, Fort Bliss, TX. RW Qual. Time: 500 Hrs. Vp, Membership Enrollment, Old Bill Chapter.

Lee, Donald J., (1LT) (M94) (Donnie) 13 Johnson Street, Fort Rucker, AL 36362. Dy: (334) 255-2529. Res: (334) 598-8077. S. Theresa. Dy: Platoon Leader, 2-229 AHR, Fort Rucker, AL. Rtg: IP. MTP. RW Qual. Time: 1,800 Hrs.

Lee, Jong-Hyuk, (CPT) (M91) 94-550 Lumiauw Street, No. J201, Waluaha, HI 96797. Dy: (808) 656-1344. Res: (808) 676-1531. S. So-Young. Dy: Troop Commander, C Troop, 5-9 Cav, WAAAF, HI. RW Qual. Time: 600 Hrs.

Lee, Stephen, (CPT) (M94) 46-163 Nahiku Place, Kaneohe, HI 96744. Dy: (808) 433-5758. Res: (808) 247-8529. Dy: Army Physician.

Lehman, William S., (CPT) (M93) (Scott) 109 Dakota Avenue, Johnston, PA 15904. S. Youngjoo. Rtg: AA. RW Qual. Time: 700 Hrs.

Lemons, Timothy R., (CPT) (M93) (Tim) 417 Oakgrove Drive, Fayetteville, NC 28314. Dy: (919) 396-5217. Res: (919) 868-7355. Dy: B Co, 1-58th Avn Regt, (Airborne) (Corps). RW Qual. Time: 750 Hrs.

Lenz, Hugo F., (1LT) (M91) North Country Chp VP Memb, P.O. Box 441, Great Bend, NY 13643. Dy: (315) 772-9696. Res: (315) 493-9643. Dy: 10th Avn Bde. Rtg: AA. RW Qual. Time: 700 Hrs. Vp, Membership Enrollment, North Country Chapter.

Lenzmeier, Scott M., (2LT) (M95) 35 Kirby Street, Fort Rucker, AL 36362-2237. Dy: (334) 255-3311. Res: (334) 598-1511. S. Becky. Dy: Flight Student, D Co, 1/145th.

Levins, Mark S., (CPT) (M94) 4250 East Foothills Drive, No. 12109, Sierra Vista, AZ 85635. Res: (520) 515-0164. RW Qual. Time: 565 Hrs.

Lewis, Jerry M., (2LT) (M94) P.O. Box 620122, Fort Rucker, AL 36362-0122. Dy: (334) 255-9090. Res: (334) 503-9464. Dy: D Co, 1/145th Avn, Flight School/ERW, Fort Rucker, AL. Time: 66 Hrs.

Lewis, Ronald F., (CPT) (M94) (Ron) 5850-2 Dupast Street, Fort Hood, TX 76544. Dy: (817) 287-2960. Res: (817) 539-2724. S. Denise. Dy: A Co Cdr, Rtg: AA TP. RW Qual. Time: 1,000 Hrs.

Lincoln, Robert W., (CPT) (M86) PSC 1, Box 5628, APO WA 34001. S. Diane. Dy: A Co, 1/228th Avn, Panama, Rtg: AA. RW Qual. Time: 1,006 Hrs./Cbt 110 AM/1.

Lindenmeyer, Victor C., (1LT) (M91) (Vic) 508 Deepth Drive, Fayetteville, NC 28311. Res: (910) 488-9751. S. Pam. Dy: D (AMC), 82d Avn Bde, Fort Bragg, NC. Rtg: MTP. RW Qual. Time: 330 Hrs.

Lindquist, Douglas J., (2LT) (M83) 1183 Schatten Street, Oak Grove, KY 42262. Dy: (502) 798-4738. Res: (502) 431-4452. Dy: Ft. Lud, B Co, 6-101st Avn Regt.

Lindsay, John J., (CPT) (M86) 5169 Paradise Mtn Loop, Fort Irwin, CA 92310. S. Ginger. Dy: Eagle Team Ops Group, Fort Irwin, CA. Rtg: AA. RW Qual. Time: 600 Hrs.

Lingle, Christopher, (CPT) (M90) (Chris) 799 Donnell Blvd., Apt. 9, Daleville, AL 36322. Dy: (334) 255-3344. Res: (334) 598-1280. Dy: Student, AVOAC, A/1-145th, Fort Rucker, AL. RW Qual. Time: 370 Hrs.

Lippert, Andrew J., (CPT) (M94) 2836 Cook Road, Bossville, NY 13308. S. Amy.

Lippert, Thomas E., (CPT) (M90) B Co, 3/501st Avn Regt, Unit 15566, Box 467, APO AF 96297-0625. S. Kathy. Rtg: MTP. RW Qual. FW Qual. Time: 1,000 Hrs.

Little, Eric D., (1LT) (M93) 4031 Cliff Point Circle W, Colorado Springs, CO 80919-8110. S. Sandra. Dy: Fort Campbell, KY. Rtg: AA. RW Qual. Time: 335 Hrs.

Logel, Jon Scott, (CPT) (M91) (Jon) 208 Brady Road, Sackets Harbor, NY 13685. Dy: (315) 772-3757. Res: (315) 646-1719. Dy: Bn S-4, HHC, 2-25th Avn, Fort Drum, NY. RW Qual. Time: 450 Hrs.

Loggins, Sidney A., (CPT) (M91) (Big Al) 3631-A Porter Loop, Wahaiua, HI 96786-3678. Dy: (808) 656-2656. Res: (808) 624-3009. S. Grace. Dy: Wheeler AAF Operations Officer, HHC, USAG-HI, Rtg: MTP. RW Qual. Time: 1,200 Hrs./Cbt 90 AM/2.

Long, David J., (CPT) (M90) 4280 E. Foothills Drive, Apt. G2088, Sierra Vista, AZ 85635. Dy: (520) 533-2020. Res: (520) 515-0601. Dy: MIOAC, Fort Huachuca, AZ. RW Qual. Time: 410 Hrs.

Lorenz, Matthew C., (2LT) (M94) CMR 2, Box 12485, Fort Rucker, AL 36362. Dy: (334) 255-3311. Res: (334) 598-8422. Dy: D Co, 1/145th.

Lovejoy, Jessica L., (2LT) (M95) 71 A.M. Windham Drive, No. 202, Daleville, AL 36322. Dy: (334) 255-9090. Res: (334) 503-9626. S. Timothy. Dy: Flight Student, Fort Rucker.

Lowder, Ned E., (1LT) (M91) (Chip) 205 Bradley Court, Clarksville, TN 37043. Res: (615) 553-5011. S. Kristen. Dy: SA, 2-17th Cav. Rtg: AA. RW Qual. Time: 320 Hrs.

Luebke, Eric C., (CPT) (M89) (Rick) 2506 Parkview Blvd., Colorado Springs, CO 80906. Dy: (719) 526-1407. Res: (719) 578-5415. Dy: S-4, 1-4 Avn, RW Qual. Time: 1,000 Hrs./Cbt 50 AM/2.

Luke, Kirby E., (CPT) (M87) (Kirbydog) c/o Richard Luke, Route 1, Maryville, MO 64468. S. Nam Hee. Dy: HQ EUSA, RW Qual. Time: 1,500 Hrs. Past Chapter Officer.

Lukow, Ronald G., (1LT) (M91) (Ron) 6720-6 Willowbrook Drive, Fayetteville, NC 28314. Dy: (919) 396-9660. Res: (910) 868-7819. S. Catherine. Dy: 150th Combat Aviation Group, Fort Bragg, NC. RW/Qual. Time: 550 Hrs.

Lunn, Robert H., (CPT) (M85) (Chip) 7374 The Cedars Drive, O'Fallon, MO 63366. Dy: (314) 263-1296. Res: (314) 980-1854. S. Angela. Dy. XO, PEO, Avn. St. Louis, MO. RW/Qual. Time: 1,010 Hrs./Cdt 110 AM/1.

MMMMMMMM

Mabel, Scott E., (CPT) (M91) 1030 Humboldt Street, Manhattan, KS 66502. Dy: (913) 239-3985. Res: (913) 776-6264. Dy: D Co, 2-58th Avn Commander, Fort Riley, KS. RW/Qual. Time: 375 Hrs.

Macchiarella, Nickolas, (CPT) (M85) (Dan) 311 Amy Avenue, Elizabethtown, KY 42701. Dy: (502) 624-3093. Res: (502) 785-3946. S. Sue. Dy. Mounted Battlespace Battle Lab, Fort Knox, KY. Rgt. SAA. Time: 1,800 Hrs. Past Chapter Officer.

MacFarland, Chris J., (CPT) (M85) (Mac) 4079A Owlhead Court, Fort Irwin, CA 92310-5000. Dy: (619) 380-4460. Res: (619) 380-7219. S. Elizabeth. Dy. A Company, Ops Group Team Observer/Controller, Rtg AA. RW/Qual. Time: 750 Hrs. AM/1 Life Member.

Madden, Michael A.G., (CPT) (M69) (Mad Man) 63-D Morris Street, Hartford, CT 06114. Dy: (203) 231-2058. Res: (203) 278-9762. Dy: Internal Review Officer, Hqt, 76th Div (Tng), W. Hartford, CT. Rgt. AA. RW/Qual. Time: 375 Hrs. Life Member.

Madkins III, Lawrence H., (CPT) (M87) (Poncho) 1717 Webster Avenue, Fayetteville, NC 28303. Dy: (910) 396-8008. Res: (910) 822-1145. S. Teresa. Dy. Asst 5J, 4-2nd ACR. RW/Qual. Time: 920 Hrs./Cdt 70 AM/2.

Magras, Krista M., (CPT) (M90) 714 West Circle Drive, Clarksville, TN 37049. Res: (615) 503-1917. S. Patrick. Dy. Maint Plt Ldr, B Co, 7-101st Avn, Fort Campbell, KY. Rtg. AA. RW/Qual. Time: 475 Hrs.

Magras, Patrick G., (CPT) (M90) (Pat) 714 West Creek Drive, Clarksville, TN 37049. Dy: (615) 738-9633. Res: (615) 503-1977. S. Krista. Dy. A1S-3, 3-101st Avn (A8), Fort Campbell, KY. Rtg. AA. RW/Qual. Time: 725 Hrs.

Maguire, William M., (CPT) (M94) (Mack) 3621 Toano Woods Road, Toano, VA 23168. Dy: (804) 878-2290. Res: (804) 568-0535. S. Elizabeth. Dy. Commander, B Co, 1-222 Avn. Rtg. AA. RW/Qual. Time: 1,100 Hrs.

Mahony, Michael F., (CPT) (M89) (Mike) A Co, 2127 Avn, Unit 20196, Box 1713, APO AE 09165. S. Norma. Dy. AH-64 Company Commander, Helme, Germany. RW/Qual. Time: 800 Hrs./Cdt 25.

Marchand, Dale P., (1LT) (M94) B Co, 1st MI Bn, CMR 450, Box 1761, APO AE 09506. Dy: SIEWPLR Ldr, Wiesbaden, Germany. RW/Qual. FW/Qual. Time: 410 Hrs.

Marcinkowski, Robert D., (CPT) (Pi) (M91) (Ski) 1 Birchwood Court, Savannah, GA 31419. Dy: (800) 522-0937. Res: (912) 927-8203. S. Janis. Dy. HHT, 5-17 Cavalry, 2nd Inf, Korea. Rgt. SAA. IP. RW/Qual. Time: 2,050 Hrs. Life Member.

Marion, Robber L., (CPT) (M93) (Bob) 3471 Powells Crossing Ct, Woodbridge, VA 22193. Res: (703) 660-2942. S. Deborah. Dy. Graduate Student, George Mason University, Fairfax, VA. Past Chapter Officer.

Martini, Joseph T., (CPT) (M89) 3303 North Henderson Way, Clarksville, TN 37042. Dy: (502) 798-2120. Res: (615) 648-0547. S. Kelly. Dy: Asst. S, 5th Bn, 101st Avn Regt., Fort Campbell, KY. Rtg. AA. RW/Qual. Time: 500.

Martuscelli, Jeffrey D., (1LT) (M92) 302 Kelly Drive, Clarksville, TN 37042-6166. Dy: (502) 798-6093. S. Lynne. Dy. HHC, 3-101 Avn Regt, Fort Campbell, KY. RW/Qual. Time: 600 Hrs.

Marye, James M., (CPT) (M94) (Jim) 182 Siler Street, Fort Bragg, NC 28307. Dy: (910) 432-8901. Res: (910) 482-0267. S. Lisa. Dy. U.S. Army Special Operations Command, Fort Bragg, NC. RW/Qual. Time: 1,500 Hrs.

Mason, Patrick H., (CPT) (M92) 3405 Clearwater Drive, Clarksville, TN 37042. Dy: (502) 798-2224. Res: (615) 645-7880. S. Lisa. Dy. Company A, 1st Battalion, 101st Avn Div (AASLT), Fort Campbell, KY. Rtg. SAA. RW/Qual. Time: 1,600 Hrs.

Masten, Randy G., (CPT) (M91) 304 Chickasaw, Longview, TX 75005. S. Kathleen. Dy. Operations Officer, 1-228th Avn Bn, Fort Kobbe, Panama, Rtg. AA. RW/Qual. Time: 600 Hrs. Life Member.

Mathews, Gregory S., (2LT) (M94) (Greg) 203 Gilbert Street, Enterprise, AL 36330-1822. Res: (334) 247-7534. Dy: D Co, 1/145th.

Mathias, Steven D., (CPT) (M89) (Steve) 5881 B Adams Street, Fort Knox, KY 41021. Dy: (502) 624-3008. Res: (502) 942-2955. S. Pam. Dy: Avn Ops Trainer, RTD Knox, Fort Knox, KY. RW/Qual. Time: 1,300 Hrs./Cdt 100 AM/2.

Matthews, Patrick L., (CPT) (M91) (Pat) 4108 Westmeadow Drive, Apt. 205, Colorado Springs, CO 80906-6053. Dy: (719) 526-2608. Res: (719) 527-0770. Dy: Ft Ops Officer, 1-10 Cav, 4 ID (M), Fort Carson, CO. Rtg. AA. RW/Qual. Time: 250 Hrs.

Mattner, Matthew E., (CPT) (M91) (Madman) 236H Med Co (AA), CMR 402, Box 1274, APO AE 09180. S. Chi Yeon. Dy: XO. RW/Qual. Time: 725 Hrs.

Mausser, David P., (CPT) (M95) 217 Apache Drive, Apt. 6C, Enterprise, AL 36330. Dy: (334) 255-3344. S. Christine. RW/Qual. Time: 350 Hrs.

Maxcy, William J., (CPT) (M89) 2943 Rocky Branch Road, Enterprise, AL 36330-5023. Dy: (334) 255-4243. Res: (334) 393-5307. S. Becky. Dy: C Co Cdr, 1-212th Avn Regt. Rgt. IP. RW/Qual. FW/Qual. Time: 1,000 Hrs./Cdt 89 AM/1.V.

McCarthy, Daniel J., (CPT) (M91) (Mac) 6329 Lake Trail Drive, Fayetteville, NC 28304. Dy: (910) 432-7771. Res: (910) 428-0965. S. Patty. Dy: Battalion Assistant S-3, 2/82nd Avn, Fort Bragg, NC. Rtg. AA. RW/Qual. Time: 575 Hrs.

McChesnie, Michael L., (1LT) (M92) A Company, 3/227th Avn, Unit 20196, APO AE 09165. Dy: Scout Plt Ldr. RW/Qual. Time: 350 Hrs.

McConnell, Frank R., (2LT) (M94) (T) 2431 Sequoia Drive E, Mobile, AL 36689. Dy: (334) 639-5050.

McGarrity, William D., (CPT) (M93) (Bill) 113 Holmes Place S.E., Winder, GA, 31884. Res: (813) 324-7802. S. Dawn. Dy: HHC, 82nd Avn Bde, Fort Bragg, NC. RW/Qual. Time: 1,026 Hrs.

McGill, Darrick L., (1LT) (M93) 1058 S Fort Hood Street, No. 120, Killeen, TX 76541-7437. Dy: (817) 287-3092. Res: (817) 554-5137. S. Lisa. Dy: XO, HHT, 6th Cav Bde, Fort Hood, TX. RW/Qual. Time: 350 Hrs.

McKay, Michael D., (1LT) (M92) 3009 Devil's Tower, El Paso, TX 79904. Dy: (915) 568-4908. Res: (915) 755-2707. Dy: Regiment Asst Adjutant. RW/Qual. Time: 450 Hrs. 92 USMA Cadet-year.

McKinley, Brian E., (CPT) (M88) 21715 Heather Acres Drive, Apt. 5A, Watertown, NY 13601. Dy: Cdr, D12-25th Avn (AVUM), Fort Drum, NY. Rtg. MAA IP MTP. RW/Qual. FW/Qual. Time: 4,100 Hrs. Past Chapter Officer.

McKisscock, John, (1LT) (M94) (John) 740 Creekwood, Box 5, Manhattan, KS 66502. Dy: (913) 239-3136. Res: (913) 776-1133. S. Jill. Dy: A Co, 1-1 Avn.

McLean, Daniel S., (CPT) (M92) (Dan) RRR 2, Box 596, Kemp, TX 75143-9612. Res: (803) 498-8756. S. Angela. Dy: HHC, EUSA G3 Tng, Korea. Rtg. AA. RW/Qual. Time: 800 Hrs.

McMahon, Michael J., (CPT) (M94) (Mike) 205 Oak Bluff Drive, Enterprise, AL 36330. Dy: (334) 255-2672. Res: (334) 347-2252. S. Jeanette. Dy: ORSA, Directorate of Combat Developments. RW/Qual. Time: 1,000 Hrs. AM/1.

McMeen, Gary R., (CPT) (M95) (Gral) 502 Mebourne Drive, Enterprise, AL 36330. Dy: (334) 355-3999. Res: (334) 393-9817. S. Lisa Ann. Dy: Avn Personnel Mgr, Avn Prop. Fort Rucker, AL. Rtg. AA. RW/Qual. Time: 600 Hrs.

McMickle, William D., (CPT) (M89) 2839 Rosemeade Drive, Fayetteville, NC 28306. Dy: (910) 396-6101. Res: (910) 423-7751. S. Anna. Dy: 18th Avn Bde, Fort Bragg, NC. Rtg. AA. RW/Qual. Time: 780 Hrs./Cdt 50 AM/1.

McNally, John B., (CPT) (M84) 1108 Murray Pt, Plumcouth, NE 68048. Dy: (334) 255-3311. Res: (402) 235-2122. Dy: 377th Air Amb, Korea. RW/Qual. Time: 200 Hrs.

McNaughton, Brian S., (CPT) (M88) (BrDog) 2137 Singtree Drive, Clarksville, TN 37040. Dy: (602) 798-1867. Res: (615) 647-3339. S. Shellye. Dy: Platoon Leader, A Co, 1/160th SOAR (A), Fort Campbell, KY. Rtg. AA IP. Time: 1,300 Hrs. Life Member.

McRill, Glenn M., (1LT) (M91) (Spunky) 408 Oakgrove, Fayetteville, NC 28314. Dy: (910) 396-2878. Res: (910) 664-4697. Dy: A Company, 2-159th Avn, Fort Bragg, NC. RW/Qual. Time: 500 Hrs.

Meacham, Jimmy L., (CPT) (M89) 212 Wesley Drive, Ozark, AL 36350-1156. Res: (334) 774-0718. S. Syndee. Dy: DCD, Fort Rucker, AL. Rtg. AA. RW/Qual. Time: 900 Hrs./Cdt 30 Hrs.

Mellahn, Kathleen M., (1LT) (M93) (Kat) High Desert Chapter Secy, P.O. Box 414, Daggett, CA 92327. Dy: (619) 254-3283. Dy: C Co, 3/150th Avn Bn (1), Fort Irwin, CA. RW/Qual. Time: 600 Hrs. Secretary, HighDesertChapter.

Mendenhall, Cory A., (CPT) (M91) 118 Woodbury Drive, Enterprise, AL 36330. S. Brooke. Rtg. AA. TP MTP. RW/Qual. Time: 1,100 Hrs.

Mensaack, Mark D., (CPT) (M87) (Gummy) 162 Krotzy Oak Drive, Mount Laurel, NJ 08054. Dy: (914) 938-3862. Res: (914) 446-7626. S. Lori. Dy: Philosophy Instructor, USMA. RW/Qual. Time: 600 Hrs.

Merkel, Kenneth O., (CPT) (M86) (Ken) PSC 41, Box 3105, APO AE 09464. S. Anastasia. Dy: Lynx Flight Cdr, British Exch, 669 Sqdn, 4th Regt, British Army Air. Rgt. SAA. RW/Qual. Time: 1,250 Hrs.

Merritt, Layne B., (CPT) (M85) 119 King Forest Lane, Newport News, VA 23602-4251. Dy: (804) 728-5130. Res: (804) 874-3499. S. Patty. Dy: TRADOC Avn Logistics Off, Fort Monroe, VA. Rtg. SAA MTP. RW/Qual. FW/Qual. Time: 1,600 Hrs./Cdt 100.

Messersmith, Martin J., (CPT) (M94) 126 Pine Drive, Black River, NY 13612-2012. Dy: (315) 772-3320. Res: (315) 773-6605. S. Karen. Dy: S-3, 3/17 Cav, Fort Drum, NY. RW/Qual. Time: 550 Hrs.

Messitt, Todd A., (CPT) (M91) D Troop, 1-1 Cavalry, CMR 401, Box 781, APO AE 09076. S. Kelly. Dy: Cdr. RW/Qual. Time: 1,100 Hrs. Past Chapter Officer.

Metting, Daniel S., (2LT) (M93) (Dan) 6-6 Cav, 11th Avn Bde, APO AE 09140. S. Karla Jean. Dy: 11th Avn Bde, 6-6 Cav, Ilesheim, Germany. Rtg. AA. RW/Qual. Time: 388 Hrs.

Meyer, David C., (CPT) (M91) (David) 314

Dale Terrace, Clarksville, TN 37042. Dy: (502) 798-2700. Res: (615) 551-8114. Dy. C Co Commander, 1-101st Rtg SAA. RW Qual. Time: 1,080 Hrs. Life Member.

Middleton, Glen P., (CPT) (M91) 1030 Humboldt Street, Manhattan, KS 66502. Dy: (913) 239-2313. Res: (913) 776-6264. Dy. Company Commander, C Co, 4-1 Avn Regt, Fort Riley. Rtg AA. RW Qual. Time: 400 Hrs.

Ridgiff, Barry A., (CPT) (M87) (Bear) 24785 Camino Del Norte, Apt. 2, Carmel, CA 93923. Dy: (408) 242-5501. Res: (408) 624-7623. S. Margaret. Dy: E Co, Defense Language Institute. Rtg AA. Time: 1,350 Hrs.

Milred, Frank H. II, (CPT) (M90) P.O. Box 91246, Tucson, AZ 85752. Dy: 5th Army RTD, Marana, AZ. RW Qual. Time: 1,150 Hrs./Cbt 150 AM2.

Miller, Jason L., (2LT) (M94) 2840 Quail Cove, Enterprise, AL 36330. Res: (334) 347-4306. Dy: D Co, 1/145th Avn.

Miller, Joe H. II, (1LT) (M93) (Jody) 2110 Burlington Place, Fayetteville, NC 28304. Dy: (910) 396-2315. Res: (910) 425-3325. S. April. Dy: Pt Ldr, A Co, 2/82nd Avn Bde, Fort Bragg, NC. RW Qual. Time: 320 Hrs.

Miller, John P., (CPT) (M90) 124 Foxhall Drive, Enterprise, AL 36330. Dy: (334) 255-3344. Res: (334) 393-6122. Dy: A/1-145 Avn, Fort Rucker, AL. Rtg AA. RW Qual. Time: 750 Hrs.

Mill, Mark A., (CPT) (M93) (Maddog) 3414 N 9th Street, Tacoma, WA 98406-5420. S. Martina. RW Qual. Time: 400 Hrs.

Miller, Ronnie M., (CPT) (M94) 303 Brookwood, Clarksville, TN 37042. Dy: (502) 798-2858. Dy: A Co, 4-101st Avn Cbt.

Millward, Steven G., (CPT) (M94) (Steve) 45th Med Co (AA), CMR 454, Box 2736, APO AE 09250. S. Anne. Dy: Operations Officer, RW Qual. Time: 2,000 Hrs./Cbt 50 AM2.

Mingear, Darren D., (1LT) (P) (M91) (Ming) 1530 A Werner Park, Ft. Campbell, KY 42223. Dy: (502) 798-5928. Res: (615) 431-3968. S. Jill. Dy: Battle Captain, 2-17th Cav. Rtg AA. RW Qual. Time: 650 Hrs.

Mitchell, Darren S., (1LT) (M92) (Mitch) 3309 Melba Drive, Fayetteville, NC 28301-3350. Dy: (910) 396-7128. Res: (910) 822-3218. Dy: Battalion S4, HHC 3/229 ATK Avn Bn, Fort Cav. FW Qual. Time: 600 Hrs.

Moffatt, James A., (CPT) (M89) (Tony) 300 Chickasaw Road, Enterprise, AL 36330. Dy: (334) 255-5051. Res: (334) 347-0394. S. Leasa. Dy: Commander, C Co, 1-14th Avn Regt, Avn Tmp Bde, Fort Rucker, AL. Rtg AA. RW Qual. Time: 1,100 Hrs.

Moloney, Michael C., (CPT) (M93) (Mike) 1904 Antelope Trail, Harker Heights, TX 76743. Dy: (817) 288-9258. Res: (817) 698-1728. S. Joy. Dy: Co Cdr, HHS 15th M Bn (AE), Fort Hood, TX. Rtg AA. RW Qual. Time: 1,300 Hrs.

Montana, Charles L., (2LT) (M94) (Chuck) 1101 W. Preston Way, Lillington, NC 27546. Dy: (910) 396-4117. Res: (910) 639-3149. S. Regina. RW Qual. Time: 200 Hrs.

Moon, Tony L., (CPT) (M91) 4043-A Soda Mountain Dr., Fort Irwin, CA 92310. Dy: (619) 380-5583. Res: (619) 386-7072. S. Lynn. Dy: G3 Installation Aviation Officer, BIAAF, NTC. Rtg AA. RW Qual. Time: 850 Hrs. Past Chapter Officer.

Mooney, William K., (CPT) (M87) (Bill) 324 Metz Road, Seaside, CA 93955. S. Terry. Dy: Student, Defense Language Institute, Rtg AA. Past Chapter Officer.

Moore, Brian J., (1LT) (M91) 1203 Virginia Avenue, Copperas Cove, TX 76522. Dy: (817) 287-4694. Res: (817) 542-7639. S. Jaclyn. Dy: Platoon Leader, 2-502d Avn Regt, 2nd Armor Div.

Moore, Chris E., (CPT) (M86) (P.O. Box 620196, Fort Rucker, AL 36362. Dy: S-1, 1st Avn Bde, Fort Rucker, AL. Rtg AA. RW Qual. Time: 850 Hrs.

Moore, David R., (CPT) (P) (M85) 7241 Stonehaven Drive, Columbia, SC 29209. Dy: (803) 776-0160. Res: (803) 783-7657. S. Laura A. Rtg AA. RW Qual. Time: 1,200 Hrs./Cbt 100 AM1.

Moore, W. Dallas, (CPT) (M94) 774 Leigh Ann Drive, Clarksville, TN 37042. Dy: (501) 798-6601. Res: (615) 551-8340. S. YoungHee. Dy: Cdr, HHC, 4-101st Avn, 101st Avn Div (AASLT). Rtg AA. RW Qual. Time: 600 Hrs.

Moquin, Marc D., (CPT) (M88) PSC 1, Box 4875, APO AA 34001. S. Mary. Dy: Aide-de-Camp for CG, USARSO. RW Qual. Time: 1,210 Hrs./Cbt 50 AM1.

Mora, Michael E., (2LT) (M94) 118 Blackhawk Drive, Daleville, AL 36322-9310. Dy: (334) 598-9261. Dy: AVOCB Student. RW Qual. Time: 155 Hrs.

Moreno, Kenneth G., (CPT) (M89) (Greg) 505-B Reed Avenue, Fort Riley, KS 66442-1173. Dy: (913) 239-3807. Res: (913) 764-2456. S. Peggy. Dy: Assistant S3, 4th Battalion, 1st Aviation Regiment, Fort Riley, KS. Rtg AA. RW Qual. Time: 950 Hrs./Cbt 40 AM1.

Morgan, John L., (2LT) (M95) 108 Hargett Road, Daleville, AL 36322. Dy: (334) 255-3311. Res: (334) 598-8422. Dy: Student.

Morgan, Scott L., (CPT) (M94) (Scott) 8533 Enoch Drive, Lorton, VA 22079. Dy: (703) 806-7623. Res: (703) 339-4115. S. Melissa. Dy: Commander, A Co, 12th Avn Bn, Fort Belvoir, VA. Rtg AA. RW Qual. Time: 1,400 Hrs.

Morris, Donald W., (CPT) (M94) 2149 Commissary Circle, Odenton, MD 21113. Dy: (301) 677-3914. Dy: (410) 674-5702.

Mount, David M., (CPT) (M87) (Dave) 2 Andrews Drive, Daleville, AL 36322-2203. Dy: (334) 255-2313. Res: (334) 598-4037. S. Susan. Dy: Aviation Training Brigade S-1. Rtg AA. RW Qual. Time: 910 Hrs./Cbt 110 AM2.

Mounitz, Richard L., (CPT) (M94) (Rich) 71 A.M. Windham Drive, Apt. 405, Daleville, AL 36322. Dy: (334) 255-3344. Res: (334) 598-0068. Dy: D Co, 1/145th Student.

Mullin, Patrick J., (CPT) (M91) (PJ) 215 Lantana Place, Colorado Springs, CO 80911. Dy: (719) 528-0398. Res: (719) 391-1838. Dy: Platoon Leader, C/1-10 Cav, Fort Carson, CO. Rtg AA. RW Qual. Time: 600 Hrs.

Murray, Dawn M., (CPT) (M91) 117 Blackhawk Drive, Daleville, AL 36322. Dy: (334) 255-3344. Res: (334) 598-3513. Dy: AVOAC, 1/145th, Fort Rucker, AL.

Murrell, Stanley D., (CPT) (M87) (Stan) 208 Longwood Drive, Vicksburg, MS 39180. Res: (601) 636-3375. S. Julia. Dy: Asst S-3, 1-82nd Avn, Fort Bragg, NC. Rtg AA. RW Qual. Time: 900 Hrs.

Musiol, Michael J., (CPT) (M90) (Mike) 408 Lands End Drive, Fayetteville, NC 28314. Dy: (910) 396-2411. Res: (910) 868-9021. S. Leigh Ann. Dy: C Company Commander, 1-229th Avn Regt (Abn), Fort Bragg, NC. RW Qual. Time: 500 Hrs.

NNNNNNNNNN

Nair, Richard S., (CPT) (M95) (Rich) 107 Westfield Road, Enterprise, AL 36330. Res: (334) 347-7148. S. Julie. Dy: A Co, 1/145th Avn. RW Qual. Time: 900 Hrs./Cbt 235

Naughton, Michael P., (CPT) (M90) HHC Avn Bde, Unit 15435, APO AF 96257-0481. RW Qual. Time: 500Hrs./Cbt 12 AM1.

Neal, David R., (CPT) (M90) P.O. Box 620064,

Fort Rucker, AL 36362. Res: (334) 393-4742. S. Rose. Dy: AOAC, Fort Rucker, AL. A Co, 1-145th Avn Regt. RW Qual. Time: 1,250 Hrs.

Nerstheimer, Michael E., (CPT) (M92) (Mike) P.O. Box 620364, Fort Rucker, AL 36362. Dy: (334) 255-9133. Res: (334) 598-5400. Dy: Cdr, A, 1-10th Avn Regt. RW Qual. Time: 600 Hrs.

Newby, Mark A., (1LT) (M93) (Skippy) 1646 S. Jordan Drive, Clarksville, TN 37042. Dy: (502) 798-6385. Res: (615) 502-0751. S. Mindy. Dy: Platoon Ldr, A/7-101st, Fort Campbell, KY. RW Qual. Time: 400 Hrs.

Newell, Michael W., (CPT) (M91) (Mike) 1713 Settler Lane, Clarksville, TN 37042. Dy: (502) 798-4020. Res: (615) 645-2016. S. Kathleen. Dy: Asst S-3, 9-101st Avn Regt. Rtg AA. RW Qual. Time: 500 Hrs. Life Member.

Newell, Peter L., (CPT) (M82) (Pete) 112 Oakland Drive, Enterprise, AL 36330. Dy: (334) 255-1235. Res: (334) 347-1414. S. Debra. Dy: System Safety Engineer, Rtg SAA. RW Qual. Time: 1,500 Hrs. Life Member.

Newton, Brian P., (CPT) (M90) PSC 54, Box 1972, APO AE 09601. S. Janet. Dy: Maintenance Officer, E Co, 502 Avn, Aviano AB, Italy. Rtg AA. MTP. RW Qual. Time: 750 Hrs./Cbt 24

Niederhauer, Chris D., (CPT) (M93) HHC, 11th Avn Regt, CMR 416, Box 1091, APO AE 09140. S. Deonne. Dy: HHC, 11th Avn Regt, Ilesheim, Germany. RW Qual. Time: 700 Hrs.

Norby, Kurt E., (CPT) (M89) F Troop, 3-4 Cav, CMR 464, Box 565, APO AE 09226. S. Robin. Dy: Commander, F Troop, 3-4 Cavalry, Conn Barracks, Germany. Rtg SAA. RW Qual. Time: 1,450 Hrs. AM1.

Notch, Robert M., (CPT) (M89) (Bob) 3421-B Kanell Loop, Wahaiwa, HI 96786. Dy: (808) 656-3450. Res: (808) 624-1380. S. Bonnie. RW Qual. FW Qual. Time: 700 Hrs./Cbt 32 AM1.

Nugent, James, (1LT) (M91) (Jim) 825 Quail Lake Circle, Colorado Springs, CO 80906. Dy: (719) 528-5633. Res: (719) 527-1005. Dy: Troop XO, E Co, 1-10th Cav. RW Qual. Time: 350 Hrs.

OOOOOOOO

O'Brien, Patrick C., (1LT) (M90) (OB) 1015 King George Blvd., No. 426, Savannah, GA 31419. Dy: (912) 352-8914. Res: (912) 927-8766. S. Sharon. Dy: Attack Helicopter Platoon Leader, Hunter Army Airfield, RW Qual. FW Qual. Time: 600 Hrs.

Odom, Michael S., (CPT) (M90) (Mike) 3406 Granite Drive, Killeen, TX 76542. Dy: (817) 287-5957. Res: (817) 634-0402. S. Terri. Dy: 1-227 Avn Regt, 1st Cav, S-1. RW Qual. Time: 600 Hrs.

O'Donnell, Vernon E., (CPT) (M90) (Vern) 117 Montclair Boulevard, Savannah, GA 31419. Dy: (912) 352-5793. Res: (912) 920-7653. S. Ellen. Dy: Asst Bde S-4, HHC, 24th Combat Avn Bde. Rtg AA. RW Qual. Time: 850 Hrs.

Oelberg, Gregory P., (CPT) (M85) (Greg) 15056 Beacon Ridge Drive, Seneca, SC 29678. Dy: (803) 656-4785. Res: (803) 654-4184. S. Cathy. Dy: USAID, Clemson University. Rtg SAA. RW Qual. Time: 1,600 Hrs.

Offenberger, Jay D., (1LT) (M91) U.S. Embassy NICOSIA, PSC 815, FPOAE 09836-0001. S. Adria. Dy: BABLNO. RW Qual. Time: 400 Hrs.

Ohmstead, Lee S., (1LT) (M91) 15 Farewell Avenue, No. 106, Fairbanks, AK 99701-3583. Dy: (907) 353-6462. Res: (907) 458-0944. S. Tammy. Dy: D Co, 4-123rd Avn, Pt Ldr, Fort Wainwright, AK. RW Qual. Time: 500 Hrs.

Olmstead, Michael G., (2LT) (M93) (Mike) 1505 Zaeger Place, Colorado Springs, CO 80915. Dy: (719) 526-0308. Res: (719) 574-

574-2878. Dy: C Troop, 1st Squadron, 10th U.S. Cavalry, Fort Carson, CO. RW Qual. Time: 193 Hrs.

Olofsson, James P., (CPT) (M94) 246 Edith Way, Daleville, AL 36322. Dy: (334) 255-8168. S: Sike. Rtg: MTP. RW Qual. FW Qual. Time: 800 Hrs.

Olson, Keith E., (CPT) (M88) (Keith) 216 Village Green, Apt. G-7, Hopkinsville, KY 42240. Dy: (502) 798-4161. Res: (502) 880-0322. S: Toni. Dy: Bn S-4, 1-101st Avn Regt, Fort Campbell, KY. Rtg: AA. RW Qual. Time: 680 Hrs./Cbt 30

O'Neil, Steven P., (2LT) (M94) (Steve) 118 Blackhawk Drive, Daleville, AL 36322-9310. Dy: (334) 255-3311. Dy: AVOBC Student.

O'Neil, Timothy J., (CPT) (M95) (T.J.) 33 Irwin Street, Fort Rucker, AL 36362-2229. Dy: (334) 255-1020. Res: (334) 598-1262. S: Jeannene. Dy: A Co, 1-145th Avn Regt, Fort Rucker, AL. Rtg: AA. RW Qual. Time: 660 Hrs. Life Member.

Openshaw, Shane T., (CPT) (M87) 230 Metz Road, Seaside, CA 90955. Dy: (408) 656-2536. Res: (408) 393-1830. S: Suzanne. Dy: Student. US Naval Post Grad School, Monterey, CA. Rtg: SAA. IP. RW Qual. Time: 2,000 Hrs./Cbt 80 AM/1. Life Member.

Osterman, Bradley D., (2LT) (M94) 71 A.M. Windham Drive, No. 204, Daleville, AL 36322. Dy: 2-82nd Avn Bn, 18th Abn, Fort Bragg, NC. Rtg: AA. RW Qual. FW Qual. Time: 500 Hrs.

PPPPPPPP

Palmer, Steven R., (CPT) (M89) (Steve) Washington DC Chap. Treas, 10309 Fomey Loop, Fort Belvoir, VA 22060. Dy: (703) 806-6122. Res: (703) 781-6747. S: Stephanie. Dy: Cdr. HHC, Oper. Support. Airland Command. Life Member. Treasurer, Washington DC Chapter.

Panton, James W., (CPT) (M94) (Jim) 5724-2 Friedman Street, Fort Hood, Killeen, TX 76544. Dy: (817) 287-8828. Res: (817) 539-5828. S: Rhonda. Dy: Apache Plt Cnd. C. Trip, 3-6 Cav, 6th Bde. RW Qual. Time: 800 Hrs.

Park, Michael H., (CPT) (M94) (Mike) 301 Silveroak Drive, Enterprise, AL 36330. Dy: (334) 255-3341. Res: (334) 393-7020. S: Sang-Hui. Dy: Student, A Co, 1-145th Avn, Fort Rucker, AL. RW Qual. Time: 200 Hrs.

Parker, David B., (CPT) (M92) 21 Hartell Way, Fort Rucker, AL 36362. Dy: (334) 255-8486. Res: (334) 598-0087. S: Sandra. Dy: Commander, A Co, 1-223rd Avn (MTPC), Rtg SAA MTP IP. RW Qual. Time: 1,800 Hrs./Cbt 10 AM/3.

Parkhurst, Jack, (CPT) (M88) HQ USAREUR, CMR 420, Box 1211, APO AE 09063. S: Brianna. Dy: DCSOPS, Aviation USAREUR, RW Qual. Time: 1,000 Hrs.

Parrish, Michael D., (CPT) (M85) 20649 Gardendale Circle, Cupertino, CA 95014. Res: (408) 366-0488. S: Judy. Dy: Graduate Student, Stanford University, Rtg SAA. RW Qual. Time: 1,300 Hrs. Past Chapter Officer.

Pasco, Michael H., (CPT) (M94) (Java) USDAO FAO, Box 50, US Embassy Bangkok, APO AF 96546. Dy: Student, Royal Thai Army Command & General Staff College, Bangkok. Rtg: SAA. RW Qual. Time: 1,200 Hrs. Past Chapter Officer.

Pate, Lynn A., (CPT) (M94) 22 Fowler Lane, Fort Rucker, AL 36362. Dy: (334) 255-1341. Res: (334) 503-9985. S: Gina. Dy: C/1-13 Avn Regt. Rtg: AA. RW Qual. FW Qual. Time: 630 Hrs.

Patterson, Mark C., (CPT) (M92) 1128 Tobacco Road, Clarksville, TN 37042. Dy: (502) 798-7260. Res: (515) 431-2468. S: Deanna.

Dy: 2nd Bn, 160th SOAR, Fort Campbell, KY. RW Qual. Time: 1,300 Hrs./Cbt 20 AM/1.

Paulino, Kenneth P., (CPT) (M91) (Ken) 14 Division Place, Fort Rucker, AL 36362. Dy: (334) 255-3973. Res: (334) 598-2437. S: Lucille. Dy: DCD, R & D Project Officer, Rtg SAA. RW Qual. Time: 1,200 Hrs./Cbt 10

Pearson, William E., (1LT) (M93) (Will) 609 Lufkin Circle, Fayetteville, NC 28311. Dy: (910) 396-2715. Res: (919) 822-9783. Dy: Asst S-3, 1-155th Avn Regt, Fort Bragg, NC. RW Qual. FW Qual. Time: 500 Hrs.

Peaster, William R., (CPT) (M90) (Ron) Ragin' Cajun Chapter Secy, 153 Old Oak Lane, Leesville, LA 71446. Dy: (318) 531-0861. Res: (318) 239-9801. S: Jennifer. Dy: Airfield Operations Officer, Ft Det, HHC, USAF, JRTC. Rtg: AA. RW Qual. Time: 500 Hrs./Cbt 25 AM/1. Secretary, Ragin' Cajun Chapter.

Pedersen, Phillip A., (CPT) (M94) (Phil) Mid-America Chap VP Memb., 3410 Woods Drive, Manhattan, KS 66502. Dy: (913) 239-6491. Res: (913) 587-8441. S: Sonja. Dy: 4th Avn Bde Adjutant, 1st Inf Div (M), Rtg: AA. RW Qual. Time: 420 Hrs. Vp, Membership Enrollment, Mid-America Chapter.

Pelletier, Robert M., (CPT) (M84) (Bob) HQ and HQ Troop, 6th Bn, 101st Avn Regt, Fort Campbell, KY 42223. Dy: (502) 798-4709. Res: (615) 648-1287. Rtg: AA. RW Qual. Time: 780 Hrs./Cbt 7 Life Member.

Pepin, Allan M., (CPT) (M89) (All) 129 Whitehall Drive, Clarksville, TN 37042-5254. Dy: (502) 798-5064. Res: (615) 553-3716. Dy: 1-101st Avn Regt, Fort Campbell, KY. Rtg: AA. RW Qual. Time: 900 Hrs.

Perkins, Jeffery A., (CPT) (M85) (Perky) P.O. Box 1147, Fort Meade, MD 20755. S: Jill. Rtg: SAA. RW Qual. FW Qual. Time: 1,500 Hrs. Past Chapter Officer.

Perkins, Scott M., (CPT) (M91) 6129 Garden Court, Fayetteville, NC 28311. Dy: (910) 399-3789. Res: (910) 822-9146. S: Melanie. Dy: Plt Ldr, C Troop, 1-17th Cav, Fort Bragg, NC. Rtg: AA. RW Qual. Time: 600 Hrs.

Perry, Christopher, (CPT) (M93) 1305 A Wernar Park, Fort Campbell, KY 42223-0797. Dy: (615) 798-3115. Res: (615) 431-9825. S: Montie. Dy: 159th Avn Regt, Production Control Officer. Rtg: AA. RW Qual. Time: 500 Hrs. Life Member.

Perry, James S., (CPT) (M91) (Free) 100 East Lundy Drive, Fort Bragg, NC 28307. Dy: (910) 399-8999. Res: (910) 497-5308. S: Lori. Dy: Secy of the General Staff, 159th Cbt Avn Group. RW Qual. Time: 400 Hrs. Life Member.

Perry, Keye E. Jr., (2LT) (M94) 326 Candle Brook Drive, Enterprise, AL 36330. Dy: (334) 255-9961. Res: (334) 347-4811. Dy: D Co, 1/145th.

Perry, Paul S., (2LT) (M93) 750 Orchard Avenue, Ft. Meade, PA 16666. Dy: (817) 628-5086. Res: (412) 547-2380. Dy: Platoon Ldr, 15th MI Bn, Fort Hood, TX. RW Qual. FW Qual. Time: 200 Hrs.

Petrenko, Ihor, (CPT) (M93) (Guc) B/3rd MI Bn (AE), APO AP 96271. Dy: 3rd MI Bn (AE), B Company, Camp Humphreys, Korea. Rtg: AA. RW Qual. FW Qual. Time: 325 Hrs.

Petri, Gregory D., (CPT) (M85) 3396 Allen Road, Clarksville, TN 37042. Dy: (502) 798-6533. Res: (615) 648-0596. S: Barbara. Dy: 1/160th SOAR, Fort Campbell, KY. Rtg: SAA. RW Qual. Time: 2,700 Hrs./Cbt 36 AM/1.

Pettit, Robert E., (1LT(P)) (M91) (Bob) 1013 McClardy Road, Clarksville, TN 37042-8705. Dy: (615) 798-4044. Res: (615) 647-3670. S: Stephanie. Dy: Asst S-3, HHC, 2/101st Avn Regt. RW Qual. Time: 475 Hrs.

Phillips, Richard T., (CPT) (M85) (Rich) Aviation Ctr Chp VP Award, 24 Galt Lane, Fort

Rucker, AL 36362. Dy: (334) 255-8426. Res: (334) 598-2866. S: Joyce. Dy: Medevac Pilot, USAAMC AAD, Rtg SAA. RW Qual. FW Qual. Time: 1,300 Hrs. Vp, Chapter Awards, Aviation Center Chapter.

Plantanida, Nicholas A., (CPT) (M94) (Nick) 121 General Hospital, P.O. Box 705, APO AP 96205. S: Elizabeth. Dy: Flight Surgeon, 1-501st Avn. Time: 50 Hrs.

Ploca, Bernardo A., (CPT) (M91) (Benny) 290-B Abelia Place, Honolulu, HI 96818. Dy: (808) 438-2254. Res: (808) 834-4051. S: Theresa. Dy: Operations Officer, USARPAC, DCS-OPS, Fort Shafter, HI. RW Qual. FW Qual. Time: 1,211 Hrs.

Picciotto, John A. Jr., (CPT) (M87) (Jack) 525 A Merritt Road, West Point, NY 10996. Dy: (914) 938-5610. Res: (914) 446-7968. S: Maryellen. Dy: Instructor, USMA, Rtg: AA. RW Qual. Time: 950 Hrs./Cbt 44 AM/1.

Piccone, Mark A., (2LT) (M94) 75 Red Cloud Road, Fort Rucker, AL 36362-2333. Res: (334) 363-6101. S: Yvonne. Dy: Flight School Student, D Co, 1/145th Avn Regt. RW Qual. Time: 190 Hrs.

Pietsch, James C., (CPT) (M89) (Jim) 1527 Redwood Circle, Slotted, LA 70458. Dy: (504) 245-9740. S: Lisa. Dy: Lakeshore Airforn, New Orleans, LA. Rtg: AA. RW Qual. Time: 600 Hrs./Cbt 5

Pilgrim, Allen M., (CPT) (M94) (Allen) 401 Faison Avenue, Fayetteville, NC 28304. Dy: (910) 396-4114. Res: (910) 484-4905. S: Cristy. Dy: 4/2 ACR, Fort Bragg, NC. Rtg: AA MTP. RW Qual. Time: 500 Hrs.

Pinter, David J., (CPT) (M95) (Bozeman) 9267 W. Lake Carmel Dr., Mapleton, IL 61547. S: Sheila. Dy: Student. Rtg: AA. RW Qual. Time: 3,000 Hrs./Cbt 60

Poisson, Jeffrey A., (CPT) (M91) 29 Voltumo Street, Fort Bragg, NC 28307. Dy: (910) 396-7767. Res: (910) 497-5547. S: Debra. Dy: HHC, 18 Avn Bde, Fort Bragg, NC. Rtg: AA. RW Qual. FW Qual. Time: 1,000 Hrs.

Ponce, Joseph A., (CPT) (M89) (Joe) 261 Ten Eyck, No. 5, Watertown, NY 13601. Dy: (315) 772-4117. Res: (315) 788-6891. S: Renee. Rtg: AA MTP. Time: 1,200 Hrs./Cbt 104 AM/2.1V.

Price, John D., (1LT) (M92) (Dave) 1440 Wuerker Park, Apt. A, Fort Campbell, KY 42223-1185. Dy: (502) 798-7742. Res: (615) 431-5619. S: Linaye. Dy: Aeroscout Platoon Leader, Rtg: IP. RW Qual. Time: 400 Hrs.

Probert, Dana M., (2LT) (M94) 94-1007 Akhloa Street, Waipahu, HI 96797-3752. Dy: (808) 656-1186. S: Allen. RW Qual. Time: 250 Hrs.

QQQQQQQQ

Quackenbush, Robert B., (CPT) (M93) (Bob) P.O. Box 70453, Fort Bragg, NC 28307. Dy: (910) 432-2604. Res: (919) 630-0349. S: Priscilla. Dy: Bde S-1, 82nd Avn Bde, Rtg: SAA. RW Qual. Time: 1,200 Hrs.

Quiros, Milton S., (2LT) (M89) 21329 Legend Avenue, Carson, CA 90745-1709. Res: (310) 834-1623. Dy: Korea, Platoon Leader. RW Qual. Time: 300 Hrs.

RRRRRRRR

Rae, Brian E., (CPT) (M92) 4401 Bluestem Lane, Killeen, TX 76542. Dy: (817) 287-8180. Res: (817) 690-5177. S: Teresa. Dy: 1/158 Avn, P.C. Officer, Fort Hood, TX. Rtg: AA MTP. RW Qual. Time: 400 Hrs.

Rasmussen, Shawn A., (CPT) (M91) 131 S. Ives Drive, Savannah, GA 31419. Dy: (912) 352-5192. Res: (912) 927-1005. S: Renee. Dy: Company Cdr, HQ Co, HQ Cnd. Rtg: SAA. IP.

RW Qual. Time: 2, 100 Hrs.

Ratiff, William Jr., (CPT) (M88) (Brother) 400 Teal Lake Drive, Richmond Hill, GA 31324-9615. Dy: (912) 769-1423. Res: (912) 756-4639. Sp: Kristen. Dy: Commander. E Troop, 2-4 Cavalry Squadron, 24th ID, Fort Stewart, GA. RW Qual. Time: 375 Hrs.

Rauer, Scott J., (CPT) (M88) (Brid) 5 Barton's Landing Pl, Fayetteville, NC 28314. Dy: (910) 396-2645. Res: (910) 864-8529. S: Tracey. Dy: Commander, D Co, 1-229 Avn (Aik), Rtg. MTP. RW Qual. Time: 540 Hrs.

Rawlings, Joseph F., (2LT) (M94) 412 Grand Pine Avenue, Enterprise, AL 36330. Dy: (334) 255-1355. Res: (334) 393-7073. S: Melissa. Dy: Avn Officer, C Co, 1-13th Avn (Aik), Rtg. AA. RW Qual. Time: 200 Hrs.

Read, Barry K., (CPT) (M93) 90 N. Harris, Fort Rucker, AL 36362-5000. S: Amy. Dy: HHC, ATB. Time: 700 Hrs.

Reed, Joseph O., (CPT) (M94) (Joe) 109 Pratt, Enterprise, AL 36330. Res: (334) 393-9257. S: Darla. Dy: Student, Fort Rucker, AL. RW Qual. Time: 163 Hrs.

Reese, Frances V., (CPT) (M88) (Fran) 803 Mueller Street, Copperas Cove, TX 76522. Dy: (817) 287-9996. Res: (817) 542-8223. S: Jim. Dy: 2/158th Avn Bn S-4, CH-47D Pilot, Fort Hood, TX. RW Qual. Time: 700 Hrs.

Regan, Timothy J., (1LT) (M94) A Co, 603 ASA, CMP 454, Box 3564, APOAE 09250. Dy: UH60 MTR Pl Ldr, Katterbach, Germany. Rtg: MTP. RW Qual. Time: 300 Hrs.

Reinebold, Jonathan T., (CPT) (M89) 459 Mail Boulevard, No. 27, Savannah, GA 31406. Dy: (912) 352-6906. Res: (912) 925-4536.

Reinwald, Bernard C., (CPT) (M87) (Ben) 1001 Cross Timbers Trail, Harker Heights, TX 76543. Dy: (817) 288-1173. Res: (817) 690-3299. S: Melissa. Dy: Company Commander, Fort Hood, TX. Rtg. AA. RW Qual. RW Qual. Time: 1,050 Hrs.

Reynolds, John M., (CPT) (M93) 35692 County Route 194, Antwerp, NY 13608-9033. Dy: (315) 772-9957. Res: (315) 659-8218. S: Carol. Dy: Company Commander, E Co, 1-58th Avn Regt. RW Qual. Time: 625 Hrs.

Reynolds, Judd E., (CPT) (M95) 23 Norwood Court, Savannah, GA 31406. Dy: (912) 352-6668. Res: (912) 352-7381. S: Diana. Dy: Cdr, D Co, 1-24th Avn. Rtg: MTP. RW Qual.

Rice, Frederick L., (CPT) (M88) (Fred) 1320-B Werner Park, Fort Campbell, KY 42223. Dy: (502) 798-5226. Res: (615) 431-5854. S: Cindy. Dy: Asst S-4 Avn Bde, 101st Avn Div. Rtg: AA. RW Qual. Time: 900 Hrs./Cbt 75 AM/1 V. Past Chapter Officer.

Rice, Lucas B., (2LT) (M95) 99 Blackhawk Drive, Daleville, AL 36322. Dy: (334) 255-3030. Res: (334) 598-4794. Dy: Pilot.

Ridnour, Alvin J., (CPT) (M87) (Al) 3132 Joyce Drive, Orlando, FL 32827. Dy: (407) 646-5491. Res: (407) 857-1643. S: JoAnn. Dy: HSC, Mi Bn (Li), Orlando, FL. Rtg: SAA. RW Qual. RW Qual. Time: 1,100 Hrs.

Rideout, Dane D., (CPT) (M90) 914 Princeton Drive, Clarksville, TN 37042. Dy: (502) 798-2137. Res: (615) 552-8815. S: Karen. Dy: HHC, 9/101st Avn, Fort Campbell, KY. RW Qual. Time: 560 Hrs.

Ridley, Jeffrey, (1LT) (M93) (Rid) HHC, 4-501st Avn Regt, Unit 15008, Box 98, APO AP 96208. S: Annette. Dy: Ill/IV Pl, Camp Page, Korea. RW Qual. Time: 180 Hrs.

Riedel, Kyle M., (CPT) (M91) 94-593 Mulhew Street, Millers, HI 96789. Dy: (808) 656-3110. Res: (808) 625-8225. Dy: D Troop, 5th Squadron, 9th Cavalry, 25th ID, Wheeler AAF, HI. Rtg: MTP. RW Qual. Time: 1,000 Hrs.

Riggins, George W., (CPT) (M85) (Riggo) Air

Assault Chap Spec Pro, 1719 Riverhaven Drive, Adams, TN 37010-8946. Dy: (502) 798-4450. Res: (615) 358-5056. S: Genie. Dy: Asst G3 Plans 101st Airborne Division, Fort Campbell, KY. RW Qual. Time: 500 Hrs. Life Member. Other: Air Assault Chapter.

Roach, Stephen J., (CPT) (M95) 71 A.M. Windham Drive, No. 707, Daleville, AL 36322. Dy: (334) 255-9414. Res: (334) 598-1403. S: Kimberly. Dy: Student. Time: 32 Hrs.

Robertson, Jeannie, (CPT) (M91) 710 Skyline Drive, Copperas Cove, TX 76522. S: Craig. RW Qual. Time: 770 Hrs.

Roberts, Joel E., (CPT) (M87) (Joe) 103 Chowring Drive, Savannah, GA 31419-9534. Dy: (912) 352-5101. Res: (912) 927-3639. S: Tith. Dy: 224th Mi Bn MAAF, Rtg. AA. RW Qual. RW Qual. Time: 1,000 Hrs./Cbt 50 AM/1. Past Chapter Officer.

Robinson, Anthony B., (CPT) (M93) (Tony) 9115 Kelly Court NE, Lacey, WA 98516-9260. Dy: (206) 967-6912. Res: (360) 923-4054. S: Cindy. Dy: Ops Off, WA OSAC Ft Det, Fort Lewis, WA. Rtg: SAA. RW Qual. RW Qual. Time: 1,700 Hrs.

Robinson, Keith W., (CPT) (M85) 1930 Westchester Drive, Silver Spring, MD 20902. Dy: (301) 405-1142. Res: (301) 649-3893. S: Mary Ann. Dy: Graduate Student, Univ. of Maryland, College Park, MD. Rtg: AA. RW Qual. Time: 850 Hrs. Past Chapter Officer.

Rodden, Jonathan D., (CPT) (M87) 3429 Chaney Lane, Clarksville, TN 37042. Dy: (502) 798-2951. S: Silvia. Dy: TDY CAS3 & ORSA MAC III enroute to Fort Rucker, AL. RW Qual. Time: 1,300 Hrs. Life Member.

Rodgers, David P., (CPT) (M84) 5 U.S. Army PEP, PSC 36, Box 307, APO AE 09456. S: Catherine. Dy: Ex. Exchange Off. with British Forces, 671 Sqn, Middle Wallop UK. Rtg: AA. RW Qual. Time: 1,700 Hrs.

Rodriguez, Milton O., (CPT) (M89) 21 Ames Lane, Fort Rucker, AL 36362. Dy: (334) 255-1354. Res: (334) 598-4534. S: Martina. Dy: Cdr, C Co, 1-13th Avn Regt. Rtg: AA. RW Qual. RW Qual. Time: 850 Hrs./Cbt 132 AM/1.

Rogers, Patrick C., (2LT) (M94) 11 Kyle Way, Fort Rucker, AL 36362-2310. Dy: (334) 255-9730. Res: (334) 503-9739. S: Kristy. Dy: D Co, 1/145th Avn Regt.

Rojas, Jose A., (2LT) (M94) (Jose) HHC, 3-227th Avn, Unit 20196, APO AE 09165. S: Lorraine. Dy: Pl Ldr (Scouts), RW Qual. Time: 200 Hrs.

Rombough, Douglas H., (CPT) (M87) (Doug) Naval Postgraduate School, 2 University Cir, SGC 10239, Monterey, CA 93943-1029. Dy: (408) 656-2491. Res: (408) 373-5768. Dy: Student, Naval Postgraduate School. Rtg: MTP. RW Qual. Time: 1,425 Hrs.

Romeike, Ryan W., (2LT) (M94) 309 RiverView Court, Daleville, AL 36322. Res: (334) 598-1440. Dy: AVOC/ICERW Student, Fort Rucker, AL. Time: 100 Hrs.

Rooney, John C., (CPT) (M86) C Co, 3-227th Avn Regt, Unit 20196, Box 2, APO AE 09165. S: Kathy. Dy: Company Commander, Hanau, Germany. RW Qual. Time: 960 Hrs.

Rotte, Randolph R., (CPT) (M85) (Randy) 3066A Lord Siding Place, West Point, NY 10996. Dy: (914) 938-4014. Res: (914) 448-8252. S: Lisa. Dy: USMA Faculty, Dept. of Math. Rtg: AA. Time: 400 Hrs./Cbt 40

Rountree, Derek R., (CPT) (M92) 4208-D Avenida Palermo, Sierra Vista, AZ 85635. Res: (520) 452-9091. S: Carola. Dy: OAC, 11th Mi Bde, RW Qual. RW Qual. Time: 600 Hrs./Cbt 135 AM/1. Past Chapter Officer.

Ruch, Jeffrey N., (CPT) (M93) 23 Donovan Lane, Fort Rucker, AL 36362. Dy: (334) 255-3311. Res: (334) 503-9112. S: Kandice.

Dy: Flight Student, D Co, 1/145th Avn Regt.

SSSSSSSSSS

Sabatino, Philip A., (CPT) (M93) (Phil) 32 Logan Street, Fort Rucker, AL 36362-2417. Dy: (334) 255-8413. Res: (334) 598-8689. S: Perette. Dy: Commander, C Co, 1-223d Avn Regt. Rtg: AA. RW Qual. Time: 800 Hrs.

Salazar, John M., (CPT) (M88) (Mark) 216 Toodle Avenue, White Sands, NM 88002. Res: (505) 678-2229. S: Cindy. Dy: Combat Operations Analyst, Rtg: SAA. RW Qual. Time: 1,200 Hrs.

Salter, David E., (CPT) (M88) 261 Bartlett Road, Sackets Harbor, NY 13685. Dy: (315) 772-7810. Res: (315) 646-1425. S: Charlene. Dy: D Co, 325 AHB, Commander, 10th Mtn Div (L), Fort Drum, NY. Rtg: AA MTP. RW Qual. Time: 775 Hrs.

Saukkonen, Rex E., (1LT) (M92) (Rex) 965 Square Dance Lane, Fountain, CO 80817. S: Kate. Dy: Fort Carson, CO.

Schaefer, Merideth A., (CPT) (M90) PSC 1, Box 4226, APO AA 34001. S: Richard. Dy: USARSO Public Affairs, Fort Clayton, Panama. RW Qual. Time: 1,000 Hrs./Cbt 25 AM/2.

Scherick, James R., (CPT) (M93) (Jim) 1 Soldiers Field Park, Apt. 220, Boston, MA 02163. Res: (617) 493-8520. S: Lisa. Dy: Student Detachment, Harvard Business School. Rtg: AA. Time: 1,175 Hrs.

Scherter, Patrick D., (1LT) (M91) (LT Hoss) 95-017 Kuahaleri Ave., No. 322, Milani, HI 96789. Dy: (808) 656-1204. Res: (808) 623-5176. Dy: Platoon Leader, H Co, 25th Avn Regt. Rtg: AA. RW Qual. Time: 650 Hrs.

Schmacker, Eric R., (1LT) (M92) 1063 Garraty Road, San Antonio, TX 78209. Dy: (210) 916-6414. Res: (210) 804-2228. Dy: Department of Surgery, Brooke Army Medical Center, Fort Sam Houston.

Schodowski, Michael L., (CPT) (M85) (Shad) US Consulate General/Rio, Unit 3501, Box 32, APO AA 34030. S: Silvia. Dy: Foreign Area Officer, Rio de Janeiro, Brazil. Rtg: AA. RW Qual.

Schoneboom, Brad L., (CPT) (M89) (Boomer) 5960 McCully Street, Apt. 2, Fort Hood, TX 76544. Dy: (817) 287-5987. Res: (817) 539-0933. S: Woon. Dy: CH47D Pilot, Commander, F Co, 2-58th Avn Regt (ATS), Rtg: AA. RW Qual. Time: 500 Hrs./Cbt 30 AM/1 V.

Schoolcraft, David E., (CPT) (M87) 1817 Rally Lane, Harker Heights, TX 76543. Dy: (817) 287-6856. Res: (817) 698-8643. S: Debi. Dy: Cdr, HHT, Avn Bde, 1CD, Fort Hood, TX. Rtg: AA. RW Qual. Time: 655 Hrs./Cbt 6

Schmitter, Lee W., (2LT) (M93) 3805 Shellock Drive, Kileen, TX 76542-7620. Dy: (817) 287-9922. Res: (817) 628-0382. S: Kerry Ann. Dy: C Trip, 1-6 Cav, Fort Hood, TX. Time: 800 Hrs.

Schroeder, James W., (2LT) (M93) (Jim) HHC, 7-227th Avn Regt, Unit 20187, Box 147, APO AE 09165. Dy: Platoon Leader, 7th Bn, 227th Avn Regt, Hanau, Germany. Rtg: AA. RW Qual. Time: 200 Hrs.

Schuman, Bruce E., (1LT) (M94) 304 Raven Street, Enterprise, AL 36330. Dy: (334) 255-3048. Res: (334) 347-3150. S: Christina. Dy: HHC, 3/5 Pl Ldr, 2/229th RW Qual. Time: 375 Hrs.

Schweitzer, Steven J., (CPT) (M91) (Steve) 1932 A Willford Street, Fort Eustis, VA 23064. Res: (804) 689-6462. S: Wendy. Dy: B Co, 1/222nd, Fort Eustis, VA. Rtg: AA. RW Qual.

Scott, John M., (CPT) (M94) 3420 E. Henderson Way, Clarksville, TN 37042. Dy: (502) 798-3771. Res: (615) 645-5920. S: Sonia. Dy:

A/2-101st Avn Regt, Company Commander, Fort Campbell, KY. RW Qual. Time: 650 Hrs.

Sarocca, Joseph E., (2LT) (M94) (Joe) 319 Candlebrook Drive, Heald, UT 84330. Dy: (334) 255-9961. Res: (334) 347-1632. Dy: D Co, 1/145th Avn Regt.

Seaworth, Stacy M., (2LT) (M95) 111 Villa Drive, No. 42, Enterprise, AL 36330. Dy: (334) 255-9090. Res: (334) 347-3879. Dy: Student. Selosse, Gilberto, (CPT) (M90) (Tito) 517 Old Newton Road, Daleville, AL 36322-9405. Dy: (334) 255-4605. Res: (334) 598-5360. S: Mary Beth Dy: Cdr, A Co, 1-212th Avn. Rig: IP. RW Qual. Time: 1,400 Hrs.

Shafer, Jon D., (2LT) (M93) 27 Arnold Avenue, Room 27, Fort Riley, KS 66442. Dy: (913) 239-3249. Res: (913) 784-4520. Dy: 3rd Flight Platoon Leader, B Co, 4-1 Avn, Fort Riley, KS. RW Qual. Time: 268 Hrs.

Sharp, Salem L., (2LT) (M94) 1318 East Kean, Wynnewood, OK 73098. Res: (334) 503-9084. S: Lon.

Shenk, Michael L., (CPT) (M88) (Mike) 307 Brook Mead Drive, Clarksville, TN 37042. Dy: (602) 798-3355. Res: (615) 552-2062. S: Juliana. Dy: Company Commander, A Co, 1-101st Avn Regt, 101st Avn Div (Air Assault), Rig: AA, RW Qual. Time: 800 Hrs./Cbt 62 AM/1. Past Chapter Officer.

Sherrill, Chandler C., (CPT) (M86) (Skip) 5711 B Brown Avenue, Fort Knox, KY 40121. Dy: (502) 624-2745. Res: (502) 943-7023. S: Lauri. Dy: Avn Corps Trainer, Resident Tng Det, 8-229th ATKHB, Rig: SAA, RW Qual. Time: 1,015 Hrs./Cbt 75AM/2, IV. Past Chapter Officer.

Shoemaker, Brian D., (CPT) (M91) (Shoe) 220 Applewood Drive, Copperas Cove, TX 76525. Dy: (817) 288-1012. Dy: S-4, 4-227 Avn, ICD.

Shoop, Brian P., (CPT) (M87) 3806 Collier Street, No. D, Wahiawa, HI 96786-4404. Dy: (808) 565-1080. Res: (808) 624-4701. S: Bobbi. Dy: Asst S3, Avn Bde, 25th ID (L), Rig: AA, RW Qual. Time: 950 Hrs. 67 AAAA Dist Grad.

Short, Steven M., (CPT) (M94) 226 Robert Court, Winchester, KY 40391. S: P.J., RW Qual. Time: 500 Hrs.

Shotts, Christopher, (CPT) (M87) (Chris) 5880 Nutbush Place, Fayetteville, NC 28314. Dy: (910) 396-8654. Res: (919) 898-6080. S: Tamara. Dy: B Co, 1st Bn, 159th Avn Regt, Fort Bragg, NC. Rig: AA, RW Qual. Time: 750 Hrs./Cbt 6.

Shufflebarger, Newman D., (CPT) (P) (M94) 1604 Ridge Road, Leavenworth, KS 66608. Dy: (913) 758-1184. Res: (913) 758-1184. S: Christine. Dy: CGSC, Rig: SAA, RW Qual. Time: 1,100 Hrs./Cbt 60 AM/3.

Shultz, Thomas A., (2LT) (M94) (Tom) 211 Chem Drive, Ozark, AL 36360. Res: (334) 445-0662. S: Patti. Dy: Flight School, Fort Rucker, AL. Time: 70 Hrs.

Silvernail, David L., (CPT) (M88) (Nails) 1208 Windchase Drive, Clarksville, TN 37042. S: Linda. Dy: C Trp, 2-17 Cav, Fort Campbell, KY. RW Qual. Time: 800 Hrs./Cbt 70 AM/2, V.

Sinroth, Paul A., (CPT) (M89) P.O. Box 6122, Fort Hood, TX 76544. Dy: (817) 288-6148. Res: (817) 699-0821. Dy: Assistant Division Aviation Officer (ADAO), Fort Hood, Avn Bde 2AD, RW Qual. Time: 700 Hrs./Cbt 2 Past Chapter Officer.

Sinatra, Michael J., (CPT) (M86) (Mike) 115 Liveoak Drive, Enterprise, AL 36330. Dy: (334) 255-9460. Res: (334) 393-2749. S: Jacquelyn. Dy: Aviation Planning Group, Fort Rucker, AL. Rig: SAA, RW Qual. Bronze St. Michael.

Sisco, Mark A., (1LT) (M92) 5473 Bliger Court, Apt. G, Fort Polk, LA 71459. Dy: (318) 531-1864. Res: (318) 537-5826. S: Tammy. Dy:

USAG-JRTC, Ft Detach, Fort Polk, LA. RW Qual. Time: 600 Hrs.

Slagle, Joel J., (CPT) (M88) 8214 Monday Road, Coryton, TN 37721. Res: (615) 687-4957. S: Kimberly. Dy: 1-502d Avn, 2AD, Fort Hood, TX. Rig: AA, RW Qual. Time: 800 Hrs./Cbt 25 AM/1.

Stocum, Michael J., (CPT) (M92) (Mike) 2-6 Cav, CMR 416, Box 265, APO AE 09140. S: Kim. Dy: 2-6 Cav, Ilesheim, Germany. Rig: AA, RW Qual. Time: 750 Hrs.

Smart, Peter H., (CPT) (M94) 94-1008 Pula Street, Waipahu, HI 96797. Dy: (808) 856-1324. Res: (808) 688-0030. S: Alexandra. Dy: 68th Medical Detachment (Medevac), WAAF, HI. Rig: SAA, RW Qual. FW Qual. Time: 3,800 Hrs. AM/1.

Smedley, Kenneth B., (2LT) (M94) (Ken) 101 Hamard Creek Road, Enterprise, AL 36330. Dy: (334) 255-9090. Res: (334) 393-9151. Dy: C Co, 1-13th Avn Regt, Fort Rucker, AL. RW Qual. Time: 165 Hrs.

Smiley, Richard T., (CPT) (M92) 907 Sable Drive, Clarksville, TN 37042. Dy: (502) 798-6037. Res: (615) 645-5798. S: Carolyn. Dy: Cdr, HHC, 4-101st Avn Regt, Fort Campbell, KY. RW Qual. FW Qual. Time: 1,062 Hrs.

Smith, Camille D., (2LT) (M94) (Carm) 507 Briarwood Drive, Apt. 16B, Enterprise, AL 36330. Dy: (334) 255-9961. Res: (334) 347-6574. Dy: D Co, 1/145th Avn.

Smith, Chad H., (1LT) (M92) (Chad) 2425 McKinley Avenue, Apt. 30, El Paso, TX 79930. Dy: (915) 568-8916. Res: (915) 565-4741. Dy: T Troop, 43 ACR, Fort Bliss, TX. RW Qual. Time: 450 Hrs.

Smith, Don E., (1LT) (M91) (IceMan) 1411 A Werner Park, Fort Campbell, KY 42223. Dy: (502) 798-5215. Res: (615) 431-2084. S: Kristi. Dy: 2-17 Cavalry Regiment, Fort Campbell, KY. RW Qual. FW Qual. Time: 700 Hrs.

Smith, Michael W., (2LT) (M94) 27 Johnson Street, Fort Rucker, AL 36362. Dy: (334) 255-3311. Res: (334) 598-8657. S: Tiffany. Dy: Student, Aviation.

Smith, Stanley O., (CPT) (M92) (Stan) 5948 Dalton Road, Fayetteville, NC 28314. Dy: (919) 399-5543. Res: (919) 867-9193. S: Lisa. Dy: Cdr, A Co, 1-58th Avn, Fort Bragg, NC. Rig: MTP. RW Qual. Time: 700 Hrs.

Smith, Stephen T., (CPT) (M88) (Troy) 1201 B Werner Park, #B, Fort Campbell, KY 42223. Dy: (502) 798-4444. Res: (615) 431-5540. S: Tania. Dy: Cdr Co B, 5th Bn, 101st Avn Regt. Time: 1,050 Hrs.

Snyder, Deborah L., (CPT) (M89) (Debbie) Colonial Virginia VP Memb, 404 Willard's Way, Yorktown, VA 23093. Dy: (804) 878-3462. Res: (804) 766-0911. S: Donald. Dy: Bn S-3. RW Qual. Time: 800 Hrs./Cbt 70 AM/1. AA Member, Past Chapter Officer.

Solms, Timothy B., (CPT) (M91) (Tim) 535 N. May Street, Southern Pines, NC 28387. Dy: (910) 396-5254. Res: (919) 892-8182. S: Karen. Dy: Asst S3, 229th ATKHB, Fort Bragg, NC. RW Qual. Time: 600 Hrs.

Sones, Bruce V., (CPT) (M89) (Sonze) 6521 Hampton Way, Apt. V20, Columbus, GA 31907. Dy: (706) 545-5325. Dy: Instructor/Writer, Infantry School, Fort Benning, GA. Past Chapter Officer.

Soracco, Jeff D., (CPT) (M88) 5 Countywalk Court, Savannah, GA 31419-3155. Dy: (912) 352-6007. Res: (912) 925-7935. S: Lori. Dy: B Co, 2-159.

Southard, William C., (CPT) (M93) (Clark) P.O. Box 3336, Fort Leavenworth, KS 66027. Dy: (913) 684-9661. Res: (913) 651-3227. S: Rose. Dy: Operations Officer, Battle Cmt Tng Program, Rig: AA, RW Qual. Time: 900 Hrs./Cbt 100 AM/1. Life Member.

Sparkman, Kurt H., (2LT) (M93) (Sparky) 505 Briarwood Drive, No. F8, Enterprise, AL 36330. Dy: (334) 255-3311. Res: (334) 393-7220. S: Heidi. Dy: Flight Student, D Co, 1-145th Avn. RW Qual. Time: 200 Hrs.

Speer, Chris, (CPT) (M94) 3484 Nesbit Road, Fayetteville, NC 28311. Dy: (910) 822-3482. S: Melissa. Dy: Bde Asst, S3, 82nd Avn Bde, Fort Bragg, NC. Rig: AA, RW Qual. Time: 275 Hrs.

Spencer, Richard C., (2LT) (M95) (Spence) 145 Lakeview Drive, Daleville, AL 36322. Dy: (334) 503-9669. Res: (334) 503-9669. S: Annamaria. Dy: D Co, 1/145th Avn Regt. Time: 110 Hrs.

Spencer, Thomas F., (CPT) (M91) (Tom) HHC, 1 AD, CMR 438, Box 2474, APO AE 09111. S: Wendy. Dy: HHC, 1st AD Bad Kreuznach, Germany. RW Qual. FW Qual. Time: 500 Hrs.

Spuhl, Robert A., (CPT) (M94) (Bob) 3703 Lake Oak Ridge Drive, Enterprise, AL 36330-6439. Dy: (334) 255-1225. Res: (334) 393-6424. S: Cheryl. Dy: Instructor, Aviation Officer, Basic Course (AVCBC), Fort Rucker, AL. RW Qual. Time: 680 Hrs.

Staus, Thomas H., (CPT) (M91) 2004 Theresa Circle, Harker Heights, TX 76543. Dy: (817) 267-8069. Res: (817) 898-3002. Dy: 6th Cav Bde, Fort Hood, TX, Adjutant. RW Qual. Time: 650 Hrs.

St. Clair, Michael W., (CPT) (M91) (Mike) 1624 Mankato Court, Claremont, CA 91711. Res: (909) 821-2252. S: Katherine. Dy: 2nd Squadron, 1st Cav Regiment, Rig: AA, RW Qual. FW Qual. Time: 582 Hrs. Past Chapter Officer.

Steckel, Timothy M., (2LT) (M93) (Steeck) 905 Pierre Street, Manhattan, KS 66502. Dy: (913) 239-3984. Res: (913) 537-1307. Dy: F Co, 1st Avn, Fort Riley, KS. RW Qual. Time: 180 Hrs.

Steele, Paul M., (CPT) (M88) 10391 Fomey Loop, Fort Belvoir, VA 22060. Dy: (703) 704-1392. Res: (703) 781-6154. S: Estela. Dy: Night Vision Directorate, Fort Belvoir, VA. Rig: SAA, RW Qual. Time: 1,000 Hrs. Life Member. Past Chapter Officer.

Steinke, Cory, (CPT) (M88) 9808-A Bearly Loop, Fort Drum, NY 13603. Dy: (315) 772-3274. Res: (315) 773-5413. S: Carrie. Dy: Commander, B Troop, 3-17 Cavalry Squadron, 10th Avn Bde, 10th Mtn Div, Fort: SAA, IP. RW Qual. Time: 2,280 Hrs. Life Member.

Stencavage, Darla L., (2LT) (M94) 206 W Southfield Drive, Savannah, GA 31419-9707. Dy: (912) 353-2764. Res: (912) 920-2692. S: Peter. M. Dy: OH-58 Pilot, Hunter Army Airfield, GA. RW Qual. Time: 183 Hrs.

Stephens, Gary D., (CPT) (M94) 2303 Simone Drive, Killeen, TX 76543. S: Jodi. Dy: Commander, Rig: MTP. RW Qual. Time: 750 Hrs./Cbt 29 AM/2.

Stiems, Eric J., (CPT) (M91) 116 Oliver Drive, Enterprise, AL 36330. Dy: (334) 255-5060. Res: (334) 393-7440. S: Stowe. Dy: HHD, 1-14th Avn Regt, Fort Rucker, AL. RW Qual. Time: 500 Hrs.

Stiller, Albert H., (CPT) (M91) (Al) 4402 Catalina Court, Concord, CA 94521. S: Melissa. Dy: 5-158th Avn Regt, Giebelstadt, Germany. RW Qual. Time: 900 Hrs.

Stokes, Brian J., (CPT) (M91) 42 Bradford Avenue, Pittsburgh, PA 15205. Dy: HHC, 1-501st Avn, Korea. RW Qual. Time: 400 Hrs.

Stokes, David L., (CPT) (M85) (Dave) 95 Dilkes Drive, Newport News, VA 23602. Dy: (804) 878-2353. Res: (804) 988-0603. Dy: Commander, D Company, 1/222nd Avn Regt, Fort Eustis, VA. Rig: AA, IP. RW Qual. FW Qual. Time: 2,000 Hrs. Life Member.

Stokes, John P., (CPT) (M85) 108 Crandal Street, Fort Huachuca, AZ 85613. Dy: (602) 333-3982. S: Sandy. Dy: Commander, HSC 304th MI Bn, Fort Huachuca, AZ. Rig: SAA. RW Qual. FW Qual. Time: 1,450 Hrs.

Stote, Paul E., (CPT) (M94) 3417 Clearwater Drive, Clarksville, TN 37042. Dy: (502) 798-6673. Res: (615) 647-9849. S: Kim. Dy: Asst. Operations Officer, HHC, 9-101st Avn. RW Qual. Time: 350 Hrs.

Stringer, David B., (1LT) (M94) 2190 Memorial Drive, Apt. 448, Clarksville, TN 37043. Dy: (502) 798-4565. Res: (615) 647-9494. Dy: Ft. Lud. A Co, 3/16th Avn. RW Qual. Time: 217 Hrs.

Stringer, Elisabeth P., (2LT) (M85) 140 Woodfield Place, Enterprise, AL 36330. Dy: (334) 255-9090. Res: (334) 347-8996. Dy: D Co, 1/145th Avn.

Sullivan, Stephen K., (2LT) (M94) 507 Briarwood Drive, Apt. 12D, Enterprise, AL 36330. Dy: (334) 255-3311. Res: (334) 347-1000. Dy: Student, Fort Rucker, AL. Time: 105 Hrs.

Sweeney, Erin M., (CPT) (M88) 2845 Scenic Drive, Clarksville, TN 37043. Dy: (615) 798-5512. Res: (615) 358-5559. S: Raymon. Dy: AVUM Ft. Lud. B Co, 7-101st Avn. Fort Campbell, KY. Rig: MTP. RW Qual. Time: 700 Hrs.

Swift, Jennifer K., (1LT) (M93) 4 Co, 603rd ASB, CMR 454, Box 3557, APO AE 09250. Dy: Maintenance Platoon Leader, Katterbach Army Airfield. Rig: MTP. RW Qual. Time: 250 Hrs.

Switzer, Michael R., (CPT) (M83) (Switz) 805 Pemberton Place, Clarksville, TN 37042-5858. Dy: (502) 798-1452. Res: (615) 431-7913. Dy: Light Attack Helicopter Plt Ldr, B Co, 1-160th SOAR (A). Rig: SAA. RW Qual. Time: 2,000 Hrs. Life Member. Past Chapter Officer.

Symonds, Brian C., (2LT) (M93) (B) 22 Sugar Cane Drive, Savannah, GA 31419. Dy: (912) 353-2439. Res: (912) 925-8885. S: Erin. Dy: XO HHC, 4-24th Avn. Regt, Hunter Army Airfield, GAR. RW Qual. Time: 250 Hrs.

TTTTTTTT

Tarantino, Michael S., (2LT) (M94) (Mike) P.O. Box 620143, Fort Rucker, AL 36362-0143. Dy: (334) 255-3311. Res: (334) 503-9742. Dy: D Co, 1/145th Avn, Fort Rucker, AL. Time: 80 Hrs.

Taylor, Brian H., (1LT) (M92) 207th Avn Co, Unit 29231, Box 88, APO AE 09102. RW Qual. Time: 450 Hrs.

Taylor, Fredericks, (2LT) (M95) CMR 2, Box 12133, Fort Rucker, AL 36362. Dy: (334) 255-3311. Res: (334) 503-9561. Dy: D Co, 1/145, 1st Avn. Bde.

Taylor, Mark C., (CPT) (M87) Savannah Chapter VP Prog., 144 Bordeaux Lane, Savannah, GA 31419. Dy: (912) 352-6719. Res: (912) 921-0019. S: Jill. Dy: Commander, C Company, 1-24, Hunter Army Airfield. Rig: AA. RW Qual. Time: 800 Hrs. Vp, Programs, Savannah Chapter.

Taylor, Roshawna M., (1LT) (M92) (Shawna) Route 2, Box 271-4, Cameron, NC 28326. Dy: (910) 396-3850. Res: (919) 499-2934. Dy: Asst Group S-4, A Co, 1/158th Avn. Regt, Fort Bragg. RW Qual. Time: 400 Hrs.

Templin, Roy D., (CPT) (M86) 4737 Chester Harris Rd., Woodlawn, TN 37191. Dy: (502) 798-4301. Res: (615) 326-9355. S: Leslie. Dy: HHC DISCOM, 101st Avn Div (AASLT), Fort Campbell, KY. Rig: MTP. RW Qual. Time: 1,100 Hrs./Cdt 17

Theiler, Hugh A., (CPT) (M91) 650 Ashley Lane, Enterprise, AL 36330. Dy: (334) 255-3344. Res: (334) 393-6601. S: Kelle. Dy:

A/1-145th Avn, AVQC Student, Fort Rucker, AL. Rig: AA. RW Qual. Time: 650 Hrs.

Thomas, Larry W., (CPT) (M93) 223 Bentley Drive, Newport News, VA 23602. Dy: (804) 878-3958. Res: (804) 874-3973. S: Karen. Dy: Commander, 1098th Transportation Company, Fort Eustis, VA.

Thomas, Mimi H., (CPT) (M91) 201 Lookout Ridge Blvd., Apt. 636, Harker Heights, TX 76543. Dy: (817) 287-4718. Dy: HHC, 2/158th Avn. Fort Hood, TX. RW Qual. Time: 650 Hrs.

Thomas, Trent R., (2LT) (M95) 142 Brian Court, Daleville, AL 36322. Dy: (334) 598-9090. Res: (334) 598-6024. S: Kristin. Dy: D Co, 1/145, Fort Rucker, AL. Time: 100 Hrs.

Thompson, Brian L., (CPT) (M89) 3402 Chaney Lane, Clarksville, TN 37042-5617. Dy: (502) 798-1847. Res: (615) 431-7046. S: Annette. Dy: 150th SOAR (A), Fort Campbell, KY. Rig: AA MTP. RW Qual. Time: 800 Hrs.

Thompson, Wiley C., (CPT) (M92) Old Elk Chapter Treas., 5261A McNeil N. Drive, Fort Bliss, TX 79906-6104. Dy: (915) 568-8853. Res: (915) 565-7359. S: Kristina. Dy: Commander, S Troop, 4/3 ACR, Treasurer, Old Bill Chapter.

Thomson, Mark H., (CPT) (M95) 105 Oakview Circle, Enterprise, AL 36330. Dy: (334) 255-3344. Res: (334) 393-4635. S: Michele. Dy: AVQC Student, A Co, 1/145th Avn. RW Qual. Time: 450 Hrs.

Terney, Patrick E., (CPT) (M92) (Pat) P.O. Box 90, Fort Campbell, KY 42223. Dy: (502) 798-1860. Res: (615) 358-9625. S: Sandy. Dy: C Co, 1-160th, Fort Campbell, KY. Rig: AA. RW Qual. Time: 1,350 Hrs.

Tillman, Anthony L., (CPT) (M94) (Andy) 107 Pratt Drive, Enterprise, AL 36330. Dy: (334) 255-5084. Res: (334) 393-3687. S: Kati. Dy: Platoon Leader.

Tinnesand, Scott B., (1LT) (M91) A Troop, 2/6 Cav, CMR 416, Box 257, APO AE 09140. Dy: Flight Ops Officer. RW Qual. Time: 800 Hrs.

Tisdale, Valen S., (CPT) (M87) (Val) 109 Country Walk Circle, Savannah, GA 31419. Dy: (912) 352-6773. Res: (912) 920-1536. S: Lisa A. Dy: HHC Commander, 4th Bn, 24th Avn. Regt, Hunter Army Airfield, GA. Rig: AA. RW Qual. Time: 800 Hrs.

Tobin, Vincent M., (CPT) (M88) (Vince) 387-C Bergin Drive, Monterey, CA 93940. Dy: (408) 656-2491. Res: (408) 657-0939. S: Karla. Dy: Naval Postgraduate School, Monterey, CA. Rig: AA. RW Qual. Time: 829 Hrs. AM1.

Torres, Mark F., (CPT) (M94) (Torch) 2 Calle Zanate, Santa Fe, NM 87505. S: Jeneuse. Dy: Flight Surgeon. RW Qual. Time: 300 Hrs./Cdt 10

Toumjan, Juliana L., (CPT) (M88) (Julie) 910 Gary Lane, Hopkinsville, KY 42240. Dy: (502) 798-7363. Res: (502) 886-5131. S: Stephen A. Dy: Cdr, B/4-101st Avn. Regt, Fort Campbell, KY. Rig: AA. RW Qual. Time: 600 Hrs. AM1.

Toumjan, Steven A., (CPT) (M89) (Steve) 910 Gary Lane, Hopkinsville, KY 42240-9369. S: Juliana. Dy: D-1-160th SOAR (A), Fort Campbell, KY. Rig: AA. RW Qual. Time: 1,300 Hrs./Cdt 50 AM1.

Traylor, John M., (CPT) (M86) (Mark) HHC, Avn Bde, Unit 15435, APO AP 96257. S: Karole. Dy: Deputy Installation Commander, Camp Stanley, Korea. Rig: AA. RW Qual. Time: 750 Hrs.

Truett, Terry L., (CPT) (M94) HHC 7-227 Avn, CMR 416, Box 558, APO AE 09140. S: Stephanie. RW Qual. Time: 800 Hrs. AM1.

Trujillo, Howard L., (CPT) (M93) 6/6 Cavalry, CMR 416, Box 558, APO AE 09140. S: Sherry. Dy: HHT Commander, Ilesheim, Germany. RW Qual. Time: 260 Hrs./Cdt 13

Tuftie, Bruce J., (CPT) (M91) 3413 East Henderson Way, Clarksville, TN 37042. Res: (615) 647-2082. S: Lana. Dy: A-2/160th SOAR (A), Fort Campbell, KY. RW Qual. Time: 900 Hrs.

Turbak, Lori L., (2LT) (M94) 805 11th Avenue, Paterson, NJ 07514. Res: (201) 977-8682. S: Michael. Dy: Flight School, Fort Rucker, AL.

Turner, Joel Todd, (2LT) (M94) (Todd) 99 Candlebrook Drive, Enterprise, AL 36330. Dy: (334) 255-9090. Res: (334) 347-8034. Dy: D Co, 1/145th Avn. Regt.

Turner, Richard J., (CPT) (M87) (Rich) 706-A Wright Avenue, Wahiawa, HI 96786. Dy: (808) 856-2551. Res: (808) 624-5574. S: Arnye. Dy: Cdr, D Co, 4-25th Avn. Regt, Rig: AA MTP. RW Qual. Time: 600 Hrs./Cdt 50 AM1.

Tussing, Jon M., (1LT) (M94) C Co, 2-227th Avn, Unit 20195, Box 1596, APO AE 09185. S: Karen. Dy: AH-64 Attack Platoon Leader, Hanau, Germany. Rig: AA. RW Qual. Time: 425 Hrs.

UUUUUUUU

Ullrich, Chris R., (CPT) (M93) (Dr. Uly) 2309 Raspberry Drive, Manhattan, KS 66502. Dy: (913) 239-8273. Res: (913) 776-7668. S: Mary Claire. Dy: 4th Bde Surgeon. Time: 40 Hrs.

Unrath, Craig S., (CPT) (M91) 71 A.M. Windham Drive, No. 102, Daleville, AL 36322. Dy: (334) 255-3344. Res: (334) 598-1836. S: Melissa. Dy: AVQC, Fort Rucker, AL. Rig: AA. RW Qual. FW Qual. Time: 940 Hrs.

VVVVVVVV

Vanasse, Meg, (CPT) (M89) (Meg) Route 3, Box 32, Cameron, NC 28328. Dy: (910) 432-0805. Res: (919) 499-1238. S: Emmitt. Dy: HHC Cdr. Rig: AA. RW Qual. Time: 1,100 Hrs.

Vannoy, John M., (1LT) (M91) 110 Woodfield Place, Enterprise, AL 36330. Res: (334) 393-7025. S: Army. Dy: Advance Course, A Co, 1/145th Avn. Regt, MTP. RW Qual. Time: 650 Hrs. AM1. Past Chapter Officer.

Van Prooyen, Peter R., (CPT) (M94) 40 Olsen Drive, Fort Rucker, AL 36362. Res: (334) 598-1237. S: Lisa. Dy: A Co, 1/145th Avn, OAC Student. RW Qual. Time: 160 Hrs.

Van Riper, Steven G., (1LT) (M92) 1509 Werner Park, No. 4, Fort Campbell, KY 42223-1131. Dy: (502) 798-3698. Res: (615) 551-9734. S: Army. Dy: Executive Officer, D Co, 2-101 Avn (AVUM), Fort Campbell, KY. RW Qual. Time: 500 Hrs.

Vedder, Edward M., (2LT) (M95) 34 Somerset Parkway, Daleville, AL 36322. Dy: (334) 255-9090. Res: (334) 503-9443. S: Jennifer. Dy: IERW Student, D Co, 1/145th Avn.

Vergez, Norbert E., (CPT) (M91) (Bert) Colonial Virginia VP Prog., 1953-A Hagood Street, Fort Eustis, VA 23604. Dy: (804) 878-6841. Res: (804) 889-6779. S: Marlon. Dy: U.S. Army Aviation Logistics School, Fort Eustis, VA. Rig: MTP. RW Qual. Time: 600 Hrs. Vp, Programs, Colonial Virginia Chapter.

Viola, James A., (CPT) (M85) (Toby) 158 Bordeaux Lane, Savannah, GA 31419-2864. Dy: (912) 352-6224. Res: (912) 927-6059. S: Sophia. Dy: Ft. Lud. B Co, 3/160th SOAR (A), Hunter Army Airfield, Savannah, GA. Rig: SAA. RW Qual. FW Qual. Time: 1,900 Hrs./Cdt 25 Life Member.

Vizzari, Kevin A., (CPT) (M93) (V) 11702 Brandon Road, Philadelphia, PA 19154. Dy: S3 Plans Officer, 6th Cav, Fort Hood, TX. RW Qual. Time: 600 Hrs./Cdt 100 AM1.

Vogelman, Lee A., (CPT) (M95) PSC 31B, Box 276, APO AP 96297. Dy: AD Flight Surgeon.

Volkin, Ron S., (1LT) (M91) (Ron) 4450 Hennings Drive, Colorado Springs, CO 80911-3228. Dy: (719) 526-0298. Res: (719) 391-8689. S. Chert. Dy: Troop Executive Officer, C Troop, 1-10th Cav. Rtg. AA. RW Qual. Time: 800 Hrs.

Vollmuth, Robert J., (CPT) (M82) 824 Iris Lane, Clarksville, TN 37042. Dy: (502) 798-5658. Res: (615) 431-3040. Dy: Aviation Maintenance Officer, 50th Medical Company (Air Ambulance) Rtg. MTP. RW Qual. FW Qual. Time: 1,100 Hrs. 93 Airsea Rescue.

vonEschenbach, Thomas, (CPT) (M91) 724 Athens Avenue, No. 1, Fayetteville, NC 28301-4601. Dy: (910) 432-8058. Res: (910) 483-6847. S. Melissa. Dy: 1-82nd A&B Bn, Fort Bragg, NC. Rtg. AA. RW Qual. Time: 500 Hrs.



Waggoner, Scott T., (CPT) (M94) HHC, 4th Bde., Unit 20196, Box 103, APO AE 09165. Dy: (910) 396-9105. S. Linda. Dy: Regional Training Detachment, Fort Bragg, NC. Rtg. MTP. RW Qual. Time: 1,000 Hrs. Past Chapter Officer.

Wagner, Charlene P., (1LT) (M92) 764 Princeton Circle, Clarksville, TN 37042. Dy: (502) 798-0975. Dy: Attack Platoon Leader, 3-101st Avn Regt. RW Qual. Time: 300 Hrs.

Walach, Christopher, (CPT) (M93) HHT 5-17th Air Cav., Unit 1514, APO AP 96251. Dy: Operations Officer, Camp Stanton. RW Qual. Time: 850 Hrs.

Wallace, Kevin P., (CPT) (M86) HHD/7-159 Avn Regt. CMR, 416, Box 1792, APO AE 09140. Dy: Battalion S-3, Stork Barracks, Germany. Rtg. SAA TP. RW Qual. Time: 1,050 Hrs. Life Member.

Walraven, Kenneth E., (CPT) (M88) 1602 Man O' War, Harker Heights, TX 76543. Dy: (817) 267-9344. Res: (817) 690-8045. S. Jerry. Dy: Company Commander, HHC, 2-158th Avn Regt, 6th Cav Bde, Fort Hood, TX. RW Qual. Time: 1,100 Hrs./Cbt 70 AM/2.

Walsh, Steven P., (1LT) (M94) HHC, 3/227th Avn Regt, Unit 20196, APO AE 09165. S. Lori. Dy: Battalion S-1, Hanau, Germany.

Walters, Christian J., (1LT) (M92) 39/Bosca Court, Clarksville, TN 37040. Dy: (502) 798-9353. Res: (615) 648-3496. Dy: Ft. Lud. C Co, 3/101st Avn Regt. RW Qual. FW Qual. Time: 400 Hrs.

Ward, Chad E., (2LT) (M94) 47 Logan Street, Fort Rucker, AL 36362. Res: (334) 598-1308. S. Stephanie.

Wargacki, Darrin W., (CPT) (M89) (Maveric) 6320 S. Calle de la Mango, Heredero, AZ 86615. Dy: (520) 533-6742. Res: (520) 378-2800. S. Felicidad. Dy: MIOAC, Rtg. AA. RW Qual. FW Qual. Time: 1,300 Hrs. Life Member.

Warner, Kurtis L., (CPT) (M90) 89 N. Harris, Fort Rucker, AL 36362. Dy: (334) 255-1354. Res: (334) 598-6627. S. Barbara. Dy: C Co, 1/13th Avn.

Warren, Michael C., (CPT) (M91) (Mike) 631 End Avenue, Fort Rucker, AL 36362. Dy: (334) 255-2442. Res: (334) 598-1886. S. Angie. Dy: Chief, Utility Branch, DES, Rtg. MAA. IFE SIP. RW Qual. Time: 3,700 Hrs./Cbt 52 AM/1.

Warren, Vanessa L., (2LT) (M94) 109 Blackhawk Drive, Daleville, AL 36322. Res: (334) 598-1363. S. Greg. Dy: D Co, 1/145 Avn Regt, Fort Rucker, AL. RW Qual. Time: 190 Hrs.

Watkins, Timothy L., (CPT) (M89) 812 196th Street E, Spanaway, WA 98387-8019. Dy: (206) 967-6162. Dy: Cdr, 2/B214 Avn. Rtg. AA. RW Qual. Time: 1,000 Hrs./Cbt 2

Watson, Richard G., (CPT) (M90) (G) 935 London Green Way, Colorado Springs, CO

80906. Dy: (719) 526-8940. Res: (719) 579-0991. S. Nancy. Dy: Executive Officer, F Co, 4th Avn Regt. RW Qual. Time: 600 Hrs.

Webb, Peter A., (CPT) (M87) 85 Mahloa Place, Kailua, HI 96734. Dy: (808) 655-5202. S. Carol. Dy: Operations Officer, HHC-5D, Medical Operations Center, Rtg. SAA MTP. RW Qual. Time: 1,835 Hrs./Cbt 1 AM/1.

Weber, Patrick A., (CPT) (M89) (Pat) B Co, 3rd Mi Bn (AE), Unit 15219, Box 1222, APO AP 96271-0155. S. Angie. Dy: Operations Platoon Leader, B Co, 3rd Mi Bn (AE), Camp Humphreys, Rtg. AA. RW Qual. FW Qual. Time: 600 Hrs.

Wehmyer, Marc A., (2LT) (M93) 7176 Dayton Drive, Fayetteville, NC 28314. Dy: (910) 396-1412. Res: (910) 867-9628. S. Ashleigh. Dy: Attack Platoon Leader, C Co, 3-229th AHR, Fort Bragg, NC. RW Qual. Time: 225 Hrs. 93 AAAA USMA Cadet.

Weilman, Frederick P., (CPT) (M91) (Fred) 92-916 Panama Street, Kapolei, HI 96707. Dy: (808) 856-5520. Dy: B Company Commander, 1-25th Avn, 25th ID (L), Rtg. AA. RW Qual. Time: 953 Hrs./Cbt 46 AM/1. Past Chapter Officer.

Wiedeman, James G., (2LT) (M94) (JG) 71 A.M. Windham Drive, Apt. 400, Daleville, AL 36322. Dy: (334) 255-3311. Res: (334) 598-9584. Dy: D Co, 1/145th Avn. T: 150 Hrs.

Wilburn, James R., (2LT) (M95) 33 Gall Lane, Fort Rucker, AL 36362. Res: (334) 347-7432. S. Deanna. Dy: Student, IERW. Time: 60 Hrs.

Wild, Douglas A., (CPT) (M91) (Doug) 724 S St Asaph Street, Apt. B112, Alexandria, VA 22314-4360. Dy: (703) 325-9366. Res: (703) 836-7231. Dy: Assignment Officer, Aviation Branch PERSCOM, Alexandria, VA. Rtg: IP. RW Qual. Time: 2,000 Hrs. Past Chapter Officer.

Wiley, Kent R., (CPT) (M91) HHC, 2-227th Avn, Unit 20195, Box 1594, APO AE 09165-5000. S. Roxanne. Dy: Assistant S3, Hanau, Germany, Fleigerhorst Kaserne, RW Qual. Time: 810 Hrs. Life Member.

Wilkinson, Kenneth M., (CPT) (M93) (Kenny) 6737 St Julian Way, Fayetteville, NC 28134-5818. Dy: (910) 432-8990. Res: (910) 868-8167. S. Tonya. Dy: S-1, 2-82nd Avn, 82nd Airborne Div, Fort Bragg, NC. RW Qual. Time: 570 Hrs. Past Chapter Officer.

Williams, David E., (CPT) (M94) (Remo) 3367 Quamy Road, Fayetteville, NC 28303-4675. S. Brenda. Rtg: SAA. RW Qual. Time: 1,200 Hrs./Cbt 23

Williamson, Jack W., (1LT) (M92) 1068 N. Hermosa Drive, Anaheim, CA 92801. Res: (714) 774-5299. S. Elizabeth. Rtg: AA. RW Qual. Time: 210 Hrs.

Williams, John D., (CPT) (M86) 34 Kirby Street, Fort Rucker, AL 36362. Dy: (334) 255-2452. Res: (334) 598-6018. S. Michele. Dy: Chief, Helicopter/Gunners Branch, DOTDS, Fort Rucker, AL. RW Qual. Time: 1,500 Hrs./Cbt 25 AM/1.

Williams, Richard L., (CPT) (M94) 3632 Rolling Pine Drive, Enterprise, AL 36330. Dy: (334) 255-5041. Res: (334) 347-5153. S. Donna. Dy: Cdr, D Co, 1-14th Avn Regt. Rtg: IP. RW Qual. Time: 870 Hrs./Cbt 36 AM/1.V.

Williams, Robert L., (2LT) (M93) (Bo) 1905 Moonlight Drive, Killeen, TX 76543. Dy: (817) 288-3464. Res: (817) 699-3890. Dy: 3-4 Cav.

Wilson, Daniel A., (CPT) (M93) (Dan) 227 Valley Drive, Lansing, KS 66043-1419. S. Karen. RW Qual. Time: 1,000 Hrs.

Wilson, Robert E., (CPT) (M90) (Rob) CMR 416, Box 302, APO AE 09140. S. Julie. Dy: HHT, 2-6 Cav Commander, Ilesheim, Germany. Rtg: AA. RW Qual. Time: 700 Hrs./Cbt 17 AM/2.

Wood, David E., (CPT) (M87) (Woody) A Co, 2/501st Avn Regt, Unit 15210, APO AP 96271-0146. S. Lisa. Dy: Ops Officer, 213th "Black Cats", Camp Humphreys, Korea. Rtg: SAA. RW Qual. Time: 1,350 Hrs./Cbt 50 AM/1. Past Chapter Officer.

Wood, Marc D., (2LT) (M94) (Woody) 40 Victoria Lane, Enterprise, AL 36330. Dy: Flight School.

Woods, Kevin M., (CPT) (P) (M90) 3103 Woods Cove, Woodbridge, VA 22192-1010. Dy: (703) 697-8103. Res: (703) 491-2681. S. Michele. Dy: Operations Briefing, J33, Joint Staff, Pentagon. Rtg: SAA. RW Qual. Time: 1,350 Hrs./Cbt 30 AM/1. Past Chapter Officer.

Wright, Christopher, (CPT) (M85) 5562 Hiers, Apt. A, Fort Knox, KY 40121. Dy: (502) 624-1240. Res: (502) 942-3249. S. Cathy. Dy: Cavalry Instructor, 3-16 Cav, Fort Knox. Rtg: SAA. RW Qual.

Wuolik, Joseph A., (CPT) (M87) (Joe) 1211 Fauchey Drive, No. 4, Waterloo, NY 13601-1880. Dy: (315) 727-3744. Res: (315) 788-9218. Dy: Company Commander, HHC, 2nd Bn (Abk), 25th Avn Regt, Fort Drum, NY. Rtg: AA. RW Qual. Time: 680 Hrs./Cbt 3 AM/1.

Wyatt, Desi L., (1LT) (M94) 1805 Eisenhower Drive, Killeen, TX 76543-3132. Dy: (817) 287-6096. Res: (817) 634-5373. S. Veleska. Dy: Platoon Leader, 2-158th Avn Regt, 6th Cav. Bde., Rtg: AA. RW Qual. Time: 300 Hrs.

Wyatt, William M., (CPT) (M93) (Chris) P.O. Box 1944, Ames, IA 50010. S. Vera. Dy: Army ROTC, Iowa State University.

Yerger, Christopher, (CPT) (M93) (Chris) P.O. Box 1152, Copperas Cove, TX 76522. Dy: (817) 518-2770. Res: (817) 518-2580. S. Army. Dy: F-227th Avn (AVIM), Fort Hood, TX. Rtg: MTP. RW Qual. Time: 570 Hrs.

Yost, Steven E., (1LT) (M91) 52538 McNeil South, Fort Bliss, TX 79004. Dy: (915) 568-9825. Res: (915) 568-4135. S. Teresa. Dy: Asst S3, HHT, 4/3 ACR.

Young, Lissa V., (CPT) (M96) (Elvira) 2046 Kentucky Street, Lawrence, KS 66046. Dy: (913) 782-4545. Res: (913) 843-0105. Dy: Regional Training Team, Aviation Chief, Readiness Group, Ft. Riley. RW Qual. Time: 900 Hrs.



Zaharis, William J., (CPT) (M92) (Bill) 39 Sand Pebble Drive, The Woodlands, TX 77381. Dy: (409) 525-3402. Res: (713) 298-8617. S. Lori. Dy: RTD, 7-6 Cav Regt, Conroe, TX. RW Qual. Time: 1,070 Hrs./Cbt 10

Zygadlo, Richard M., (2LT) (M94) P.O. Box 62091, Fort Rucker, AL 36362-0291. Dy: (334) 255-3937. Res: (334) 347-0407.

HIGH TIMERS

CPT Brian E. McKinley	4,100 Hrs.
CPT Peter H. Smart	3,800 Hrs.
CPT Michael C. Warren	3,700 Hrs.
CPT David J. Pinter	3,000 Hrs.
CPT Charles A. Fish	2,900 Hrs.
CPT Gregory D. Petrik	2,700 Hrs.
CPT Erich Erker	2,500 Hrs.
CPT Robert M. Cumble	2,400 Hrs.
CPT Steven K. Brown	2,300 Hrs.
CPT Michael K. Haider	2,300 Hrs.

1995 Aviation Mission Assessment

RED -- No capability exists, or is insufficient to defeat the threat or provide the required support
AMBER -- A limited capability or quantity exists to perform the mission
GREEN -- Adequate capability and quantity exists to perform the mission

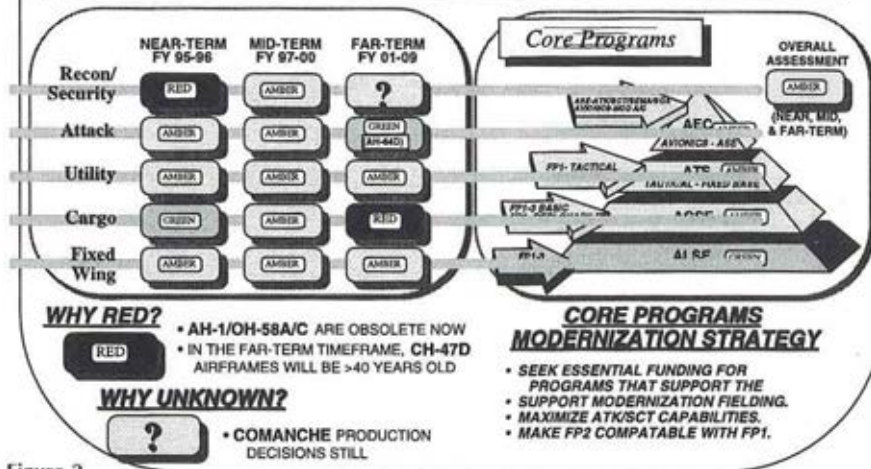

Figure 2

MOD PLAN

(Continued from Page 11)

to be part of a joint program as the other services are also seeking a replacement aircraft for their heavy lift requirements. This aircraft, anticipated in the FY2020-25 timeframe, will meet the Army's needs for a CH-47 replacement. In the interim, a CH-47D Follow-on (FO) must be established to extend the life of the Army's CH-47 fleet until the replacement aircraft is fielded. Studies are currently being conducted to determine exactly what enhancements the CH-47D(FO) will require, to include service life extension actions and enhanced sustainability objectives. This program, coupled with the capabilities of the current CH-47 fleet, will propel us well into the 21st Century until the replacement is procured.

Core programs are vital and cannot be disregarded; that's why the Aviation Branch Chief has made them his number two priority. Modernization of core programs will provide mission essential equipment, support equipment, and the new technologies required to digitize the force. Digitization of all objective aircraft, whether through design (RAH-66 and AH-64D) or appliques (UH-60 and CH-47), will bring man and machine closer together, increasing efficiency, improving situational awareness, and leveraging technology to win the information war. Core programs/modernization efforts will also enhance mission survivability, Army Airspace Command and Control (A2C2), and aircraft maintainability and supportability.

Funding constraints limit core program modernization to only those programs that directly impact on warfight capability.



Some decisions are safe. Some decisions save lives.

If America was suddenly faced with several regional conflicts, our reserves would be the cornerstone to our success. Which raises a critical question: shouldn't the helicopters they fly be the best available?

The UH-60 BLACK HAWK is a helicopter designed to provide our reserves with the speed, the navigational accuracy, the protection and the technology they need to be able to handle the increasing demands of modern warfare. It can lift 9,000 pounds. It can carry 11 combat-equipped troops. It can safely take these troops 250 nautical miles at 150 knots.

It is an aircraft built without compromise. Every rotor and gear, every seam and rivet, every drop of paint, is subject to the closest scrutiny. The design is of the highest quality. The materials are the finest on earth. The process by which they are assembled is the most efficient possible. This constant attention to detail is inspired by an unwavering focus on a clear duty: to provide the army with the most capable helicopter available.

When it comes to our reserves, the UH-60 BLACK HAWK is not just the safe decision. It is the only decision.



DEGREASE WITHOUT SOLVENTS

**FREE
DEMONSTRATION
1-800-229-3380**

Better Engineering's Jet Washers have successfully replaced PD-680 and solvent sinks at Military Bases across the country and around the world. These automatic detergent and water systems have been approved for cleaning **GUN SYSTEMS, TURBINE ENGINES & COMPONENTS, WHEELS, GSE PARTS, ETC.** Please call for details!



**BETTER
ENGINEERING** MFG.
INC.

8361 Town Center Court, Baltimore, MD 21236
(410) 931-0000 FAX 931-0053 800-229-3380

NSN's Available



GSA Contract #GS07F-5778A

While all modernized aircraft will receive NOE COMM, Have Quick II, embedded GPS and mission planning systems, only the attack, scout, and command and control aircraft will be equipped with digital maps, data modems, and mission planning data transfer systems. Likewise, advanced aircraft survivability programs, advanced threat radar jammer, and IR countermeasures (ATRJ, ATIRCM) will be fielded first to Special Operations Aircraft (SOA) and the AH-64D. This resourcing provides capability levels that match mission requirements in a fiscally constrained environment. Priorities for Ground Support Equipment, Aviation Life Support Equipment, and Air Traffic Control is consistent with those units who are first to fight as well as supporting the Aviation Modernization Plan.

The modernization plan is a prudent,

proactive course of continuous improvement. The strategy emphasizes the necessity of fully fielding both Comanche and Longbow Apache because they give the Army the highest payoff in warfighting capabilities. On the other hand, it is a balanced strategy that doesn't neglect the needs in utility, cargo, and core programs. Given adequate resourcing by Congress and the Office of the Secretary of Defense, the aviation modernization plan ensures aviation will continue to provide support across the range of military operations while significantly contributing to the Army's modernization goals and the attainment of its Force XXI objectives.

★ ★

COL Callen is Chief, Aviation Division, DDCSOPS Force Development Directorate, the Pentagon (DAMO-FDV), and LTC Kelton is the Executive Officer, DAMO-FDV, Washington, D.C.

STRATEGY

(Continued from Page 20)

craft Testbed, Advanced Helicopter Pilotage, and Logistics Rearm for Aviation.

Horizontal Technology Integration (HTI). Army aviation is developing advanced capabilities which can provide required battlefield capabilities to other members of the combined arms team, such as: Comanche computer processors, Enhanced Communication Interface Terminal, A²C²S, AMPS, Comanche 2nd Generation FLIR, RPA's Cognitive Decision Aiding System, ANVIS HUD, turbine engine technologies, and maintenance prognostics/diagnostics. Additionally, the joint Integrated Communications, Navigation, and Identification Avionics program has tremendous HTI potential.

Battle Laboratory Initiatives. Aviation participation focuses on the Force XXI objectives and improving our ability to conduct C², acquire targets, collect and disseminate battlefield information, and plan missions with increased flexibility. Near-term battle laboratory participation centers on digitization of the battlefield, early entry force design, and Theater Missile Defense. In 1995, participation will include AWE Strong Safety and AWE Theater Missile Defense sponsored by the Depth and Simultaneous Battle Lab, AWE Focused Dispatch monitored by the Mounted Battle Lab, and AWE Warrior Focus sponsored by the Dismounted Battle Lab. Aviation will also participate in Joint Precision Strike Demonstrations, Mobile Strike Force, Anti-Armor ATD, and Prairie Warrior exercises. Mid- and far-term experiments emphasize organizational redesign and integration of information age technology into Brigade through Corps. Aviation will integrate near-term and follow-on concepts such as AVTOC, A²C²S, Longbow,

Comanche, RPA, Bird Dog, and JTAGG, into these AWEs/ATDs to create a more agile, versatile, and lethal aviation force.

Conclusion. The void in production lines is disconcerting. The difference between requirement and procurement objectives for the RAH-66 will be absorbed in the float resourcing requirement, after attaining a Comanche procurement design. For the UH-60, the shortfall between the requirement and the procurement objective results in the indefinite retention of about 900 UH-1s. The resourcing of aviation at the current POM levels stretches modernization well beyond 2015 and delays retirement of the last OH-58D until at least 2023.

★ ★

Mr. Martinez is the Acting Director for Business Management, PEO, Aviation, and Mr. Miller is an Aerospace Engineer and Team Leader, Aviation Modernization Planning Group, AVRDEC, Directorate for Advanced Systems, U.S. Army ATCOM, St. Louis, MO.



"MarketPlace" offers ARMY AVIATION readers easy access to products and services that may be of interest.

RATES: Classified: First Three Lines: \$60; Additional Lines: \$20 per line. Display: \$150 per columnar inch; inclusion of artwork is subject to approval and may involve additional charges.

For further information, contact:

ARMY AVIATION, 49 Richmondville Avenue, Westport, CT 06880; Telephone: (203) 226-8184; FAX: (203) 222-9863.

AADCO Advertising makes the finest quality custom emblematic items such as patches, decals, coins, pins, caps, glassware, plasticware, t-shirts, and laser plaques. We are new AAAA members. Call us at (619) 222-2221 and see.

Lt. Colonels

Ferrier, Don V.
786 River Birch Drive
Vass, SC 28394
Mague, Michael
10971 E. Fourwing Place
Tucson, AZ 85748
Stafford, Keith R.
OGIA-E, PSC 5, Box 476
APO AE 09050

Majors

Comodeca, Thomas J.
Unit 21409, Box 1101
APO AE 09705
Ferderber, Scott M.
102 Franklin Street
Enterprise, AL 36330
Gates, Robert E.
OPC Greece
PSC 108, Box 42
APO AE 09842
Hackle, D. Lee
55 Kirby Street
Fort Rucker, AL 36362
King, Gregory L.
9901 Whitewater Drive
Burke, VA 22015
Matthews, H. Ray, Jr.
3810 South 7th St.
Arlington, VA 22204
Michael, Robert L. Jr
123 Cambridge Drive
Savannah, GA 31419
Moore, Bruce
USAE, CMR 450, Box 768
APO AE 09705
Nicholas, Freddie W.
3872 Murray Hill Road
La Mesa, CA 91941
Pacheco, Michael M.
HHC, CMTC, Unit 28208
Box 439
APO AE 09173
Schwallie, Randal A.
2427 Easy Street
Savannah, GA 31406
Stuckey, Barry L.
7516 W. Jackson Street
Pensacola, FL 32506
Weeks, Robert A.
54 Walnut Street
Fort Devens, MA 01433

Captains

Allen, Jeffrey C.
110 Lindsey Street
Enterprise, AL 36330
Banks, Bernard B.
HQ, Office of the CG
USASAC, 5001 Eisenhower
Alexandria, VA 22333
Benter, George W.
3706-B Collier Street
Wahiawa, HI 96786
Bingham, David D.
3611 Levy
Killeen, TX 76547
Boehnke, Matthew A.
105 B Woodview Drive
Ozark, AL 36360
Evans, John R.
1503 Pin Oak Court
Apt. 11
Radcliff, KY 40160
Fisher, Stephen J.
HHC, 5-158th Avn Regt
CMR 408, Box 1227
APO AE 09182
Gilliam, Anthony A.
114 Peacock Road
Daleville, AL 36322
Gillis, John W.
Corpus Christi Army Depot
Corpus Christi, TX 78419
Hau, Roland C.
A Co, 5-159th Avn Regt
Unit 26444
APO AE 09182
Henderson, Joseph P.
739 Peterson Lane
Maryville, TN 37801
Higgins, Tommy R.
1039 Angela Drive
Clarksville, TN 37042
Howard, Paul D.
Box 198, Route 1
Register, GA 30452
Janas, Joann S.
HHC, 2-501st Avn.
Unit 15188
APO AP 96271
Joyce, Stephen E.
425 Underwood Road
Jefferson, GA 30549
Kenney, Christopher
914 Erwin Court
Fort Wainwright, AK 99703
Koenig, Steven T.
HSC 3rd Mi Bn, Box 220
APO AP 96271
Krankhold, Keith J.
1309 Pickwick Place
Bloomington, IN 47401
Kraus, Karl M.
2502 Bacon Ranch Rd, #1806
Killeen, TX 76542

ARRIVALS DEPARTURES



Lehman, William S.
109 Dakota Avenue
Johnstown, PA 15904
McCarthy, Daniel J.
6329 Lake Trail Drive
Fayetteville, NC 28304
McNally, John B.
1108 Murray Pl
Plattsmouth, NE 68048
Mensack, Mark D.
162 Knotty Oak Drive
Mount Laurel, NJ 08054
Niederhauser, Chris D.
HHC, 11th Avn Regt
CMR 416, Box 1091
APO AE 09140
Polizzi, Gregory
HHC, 4-501st Avn Regt
Unit 15008
APO AP 96208
Ponce, Joseph A.
261 Ten Eyck, No. 5
Watertown, NY 13601
Rasmussen, Matthew F.
209-A Sorrell Street
Copperas Cove, TX 76522
Rice, Frederick L.
1320-B Werner Park
Fort Campbell, KY 42223
Robertson, Jeannie
710 Skyline Drive
Copperas Cove, TX 76522
Short, David M.
1606 Leland Avenue
Springfield, IL 62704
Truett, Terry L.
HHC 7-227 Avn Bn
Unit 201971, Box 223
APO AE 09165
Wellman, Frederick P.
92-916 Panama Street
Kapolei, HI 96707
Wilson, Robert E.
CMR 416, Box 302
APO AE 09140
Woods, Kevin M.
3103 Woods Cove
Woodbridge, VA 22192

Zaben, Lawrence T.
7308 Mobile Highway
Pensacola, FL 32526

1st Lieutenants

Cutchin, Allan H.
CMR 454, Box 3191
APO AE 09250
Huff, Tom T.
A Co, 6030 ASM
CMR 454, Box 3268
APO AE 09250
Sinkus, James A.
71 A.M. Windham Drive
Apt. 107
Daleville, AL 36322
Verhulst, Kenneth J.
HHC, 3/58th Avn
CMR 430, Box 983
APO AE 09096

2nd Lieutenants

Boyce, Lance P.
A Trp, 2-6 Cav
CMR 416, Box 29
APO AE 09140
Demirjian, Michael E.
5641-1 Lockridge Loop
Fort Hood, TX 76544
Dudley, Bruce E.
P.O. Box 450
Fort Drum, NY 13603
Jenkins, Harold A.
342 Conifer Drive
Fayetteville, NC 28314
McFarland, Laurel I.
16443 State Street
Granada Hills, CA 91343
Metting, Daniel S.
C Troop, 6-6 Cav
CMR 416, Box 358 09140
Noh, John S.
3600 Rainforest Lane
Killeen, TX 76542
Ott, Carl R.
505 Mall Boulevard
Apt. 707
Savannah, GA 31406
Sandoval, David W.
1520 Waterford Place
No. 5
Manhattan, KS 66502
Speth, Phillip P.
A Co, 1-2 Avn
Unit 15432
APO AP 96224
Williams, Robert L.
1905 Moonlight Drive
Killeen, TX 76543
CW4s
Hopkins, Sidney F.
3461 Gables Drive
Fayetteville, NC 28311
Williamson, Nathaniel W.
213 Sigerfos Road
Fort Benning, GA 31905

Zimmerman, John M.
68 Sandra Drive
Newport News, VA 23602

CW3s

Poirot, Gerald R.
127th Postal Co.
Unit 25016, Box R-2
APO AE 09178

CW2s

Dessinger, Michael D.
3510 Darling Drive NW
Alexandria, MN 56308
Freeman, Tyrion J.
502 End O Trail
Harker Heights, TX 76543

Hodac, Louis J.
3382 John Taylor Road
Woodlawn, TN 37191
Holland, Chris W.
153-B Brick Row
Fort Riley, KS 66442

Hutzy, Janice A.
P.O. Box 46841
Washington, DC 20050

Kennedy, James P.
104 Mammie Street
Enterprise, AL 36330

Wortner, David
C Co, 1/13th Avn
CMR 3, Box 7803
Fort Rucker, AL 36362

WO1s

Brockett, Melinda C.
503 Atalanta Street
Webster Groves, MO 63119

English, Thomas E.
2155 Deringer Circle E.
Jacksonville, FL 32225

Jones, Kevin J.
976 Lincoln Street
Apt. 104
Fort Benning, GA 31905

Kendall, Christopher
P.O. Box 457
Fort Drum, NY 13603

Marler, Jeffrey S.
A Co, 7/1st Avn
CMR 454, Box 2384
APO AE 09250

Rapp, Matthew L.
2501 Bacon Ranch Road
No. 110
Killeen, TX 76542

Smith, Robert J.
5929-B Bennet Court
Fort Polk, LA 71459

CSMs

Thomas, Richard F. CSM
615 Granger Lane
Clarksville, TN 37042

First Sergeants

Deck, Timothy W. 1SG
Hqs, 2-6 Cavalry
CMR 416, Box 231
APO AE 09140

Sittler, James R. 1SG
1-227th Attack Hel. Regt.
Fort Hood, TX 76544

Sergeants First Class

Sass, Charles H. SFC
P.O. Box 620704
Fort Rucker, AL 36362

Wells, Kenneth J. SFC
2543B Vanhooris Street
Fort Eustis, VA 23604

Sergeants

Laird, Jeffery A. SGT
P.O. Box 620773
Fort Rucker, AL 36362

Specialists

Overmyer, Edward D. SPC
C Co, 1/228th Avn Bn
APO AA 34001

Privates

Hippensteel, Michael J. PFC
K Co, 159th Avn
Hunter AAF, GA 31409

Blaschke, Gregory N. PVT
A Co., 7/159th Avn. Regt.
CMR 416, Box 1883
APO AE 09140

DACs

Means, Joseph D. Mr.
Serv-Air, Inc.
CMR 408, Box 918
APO AE 09182

Civilian

Anderson, Brian R.
8805 Mendocino Court
Albuquerque, NM 87122

Kralich, Joseph
4319 Medical Drive
No. 131-342
San Antonio, TX 78229

Retired/Other

Johnson, James E LTC
550 S. Camino Saco
Apt. 2301
Tucson, AZ 85710

Mooneyham, Joseph S. LTC
B Co, 3/501st Avn. Regt.
Unit 15568, Box 526
APO AP 96297

Nobles, John C. CW4
3835 E. Cresta Loma Cir.
Colorado Springs, CO 80911

Snitch, W. Leonard LTC
3 Troy Avenue
Wilmington, DE 19804

Stacy, John F. LTC
P.O. Box 5247BWB
Niceville, FL 32578

Swift, William D. COL
17793 Front Beach Road
Panama City Beach, FL 32413

Wilson, Walter C. Jr LTC
8534 Mathonia Avenue
Jacksonville, FL 32211

AUSTRALIA

(Continued from Page 36)

helicopter.

A Project Definition Study is due for completion by December 1995. Budgetary approval is sought for FY 1997/98 with delivery between 2000 and 2004.

The Future. Australian Army Aviation is looking aggressively towards the future where it will be capable of being employed by commanders at the operational and tactical levels of war. The key development activities which have been identified are:

- The development of an effective component of combined arms firepower and its doctrinal support base.
- Enhancement of the surveillance and reconnaissance capability, both in the interim and the long term, through technology integration within Army Aviation and its supported force elements. Particular emphasis must be given to the flow and processing of information.
- Further development of Aviation's tactical mobility capability to permit simultaneous operations in widely separated AOs. An enhanced command & control capability and an adaptable logistic support base are essential.
- All capabilities developed must enhance Army Aviation's ability to integrate into a joint or coalition force.

It has been an exciting decade to be an Australian Army Aviator. We are, however, not focussed on past success, but on the future and the imaginative employment of Army Aviation on the manoeuvre battlefield.

★ ★

LTCOL Patch is the Australian Liaison Officer to the USAAVNC.

**AIR ASSAULT
FORT CAMPBELL, KY**

CPT David J. Bouton
CW2 John A. Bruns
CW2 Archie J. Chapman, Sr.
CPT Shawn M. Chester
MAJ Reginald B. Crosson
CW2 Jesus F. Fontes
CW4 Nick J. Garcia
CPT Joseph B. Jellison
CPT John K. Johnson
MSG James M. Kearney
CPT Thomas W. Lewis
Mr. James W. Lowe
WO1 James D. McDaniel
2LT David C. Menser
CW3 Stanley L. Reed
COL Thomas M. Reeves
1LT Darin T. Richter
CW2 Benjamin D. Savage
BG Samuel S. Thompson, III
SPC Eric J. Whitehead

**ALOHA
HONOLULU, HI**

CW3 James R. Burhans

**ARIZONA
MESA, AZ**

2LT Scott E. Kahidon

**ARMADILLO
CONROE, TX**

2LT Matthew D. Dossey
Mr. John M. Taylor

**AVIATION CENTER
FORT RUCKER, AL**

CW4 Jeffrey S. Adair
2LT Christopher S. Adams
WO1 Bryon K. Anderson
WO1 David A. Angulo
Mr. Paul T. Antoniak
WO1 Nicholas J. Arganbright
WO1 Shawn A. Bainbridge
CW4 Avery R. Baker, Jr.
WO1 Gregory W. Baker
2LT David G.R. Balch
2LT Christopher S. Baril
WO1 Karen S. Barmette
CPT Robert L. Barrie, Jr.
2LT Braun P. Barton
2LT Scott P. Barton
2LT Thomas M. Bauer
2LT Christopher L. Beerbower
Mr. William Benton
CPT George R. Berry
MAJ John E. Bianchi
2LT Charles E. Bickley
CPT Michael C. Bird
Mr. Charles H. Blivins
Mr. Billy J. Blackmon
COT William W. Blackwell
Mr. William E. Blackwell
2LT Noelle M. Blanc
WO1 Shannon L. Blitchington
WO1 Kenneth D. Bogart
WO1 Patrick M. Bohlken
2LT Todd M. Bookless
WO1 James G. Boyers



**NEW
MEMBERS**



Ms. Debra L. Bozeman
Ms. Frances Bradshaw
WO1 Chad M. Breidenstein
2LT David M. Bresser
2LT Robert E. Brooks
CW2 Ute B. Brown
Mr. Kenneth Campbell
WO1 Clarence K. Carlmoro
Mr. William L. Carter
2LT Neil T. Chaffee
1LT Michael A. Charlebois
CPT Daniel L. Clark
2LT Dean T. Clark
WO1 Stephen L. Clower
2LT Kevin S. Cochie
WO1 Lee S. Conley
WO1 Carlos R. Corcino
2LT Michael P. Corcoran
SFC Ken E. Coro
2LT Donna E. Coyle
Mr. Trent Crawford
WO1 Daniel P. Cullem
CW2 Laird B. Culver
Mr. David N. Davis
2LT Neil A. Davis
CW3 Timmy M. Davis
2LT Monte E. Denehie
1LT William B. Dennis
1LT Stephen A. Devereux III
2LT Daniel S. Donahue
WO1 Johnell C. Dotson
WO1 Richard C. DuFour
CW2 Gregory A. Eastburn
2LT Joseph W. Edstrom
1LT Dustin K. Elder
CPT Mark A. Englade
CPT Gerald D. Ernst
WO1 Stephen D. Eshbaugh
WO1 Daniel T. Etter
2LT Diahann M. Evans
WO1 Brian K. Ezell
Mr. Kenneth L. Farris
WO1 Scott M. Feld
2LT Richard D. Ferguson
2LT George G. Ferido
CPT Michael T. Fisher
2LT Kevin L. Fittz
2LT William Fitzgerald
2LT Matthew J. Fox

1LT Michael D. Frazzini
WO1 Jason Y. Freeze
CW2 Ronald R. Galuppo
Mr. Frank C. Garrett
Mr. Elliott N. Garrison
Mr. Jule E. Garrison
CPT Mark R. Gasta
2LT Kevin L. Gaver
CW3 Stephen D. Gilbreth
2LT Mark C. Gillespie
2LT Kenneth R. Giraldi
2LT William T. Godfrey, Jr.
Mr. Don L. Godwin
2LT Elliott Q. Gomez
2LT Kenneth S. Goodpaster
1LT Richard H. Gordon
WO1 Joseph E. Gould
2LT Carlos R. Goveo
CW3 Steven M. Greenberg
CPT Jason V. Griffin
2LT Jeffrey C. Groskopf
2LT Christina N. Grove
2LT Fernando Guadalupe
CPT Robert E. Guidry
Mr. Bob Guillotte
Mr. Jerry L. Gwaltney
MAJ D. Lee Hackle
WO1 Jeffrey P. Hanshew
2LT Leslie E. Hanson
CPT Matt F. Hanson
WO1 Herbert C. Harris, Jr.
1LT Bryan K. Heartsfield
WO1 Jeffrey J. Hebert
2LT Jennifer S. Hebert
CW4 Gary W. Helmer, Ret.
WO1 Jose L. Hernandez
WO1 Duane S. Heitrick
Mr. Monette Hicks
2LT Christopher J. Higgins
Mr. John C. Hilboldt
CPT William R. Hogans, IV
Ms. Karen S. Holley
2LT Ronald L. Hornback
WO1 J. Kevin Howard
Mr. William Hudgens
2LT Christine M. Hunton
1LT Kier D. Jackson
Mr. Barney Jarnau
2LT Loren B. Jerlow

2LT Cheri L. Johnson
CW4 Leonard J. Johnson
Mr. Robert L. Keller
1LT Jason E. Kelley
WO1 Morris M. Kemple
WO1 Arthur J. Kenney III
2LT Kimberly J. Kessel
WO1 Darren J. King
2LT Andrew C. Kirkpatrick
1LT Robert A. Kneeland
WO1 Dean S. Kozel
2LT Karl A. Krievins
WO1 Matthew P. Kulesza
Mr. Carl Kuykendall
2LT Theodore J. Landgraf
WO1 Timothy E. Larsen
2LT Joseph Laszacs
2LT Morgan R. LaVake
2LT James R. Lee, Jr.
WO1 Michael W. Lee
WO1 James E. Lemons, Jr.
WO1 Jeff D. Linder
WO1 Miguel A. Lira
2LT Derrick M. Llewellyn
WO1 Alexander Lutz
2LT Scott M. MacIver
WO1 Charles F. Magness
WO1 Josue Maldonado
WO1 Eric W. Manchon
2LT Brett J. Manger
WO1 Scott H. Markgraf
SPC Craig A. Martin
2LT John P. Martin
CW2 Simeon I. Mason
WO1 Anthony M. Mastropietro
WO1 Wylie A. Mathis
WO1 David M. Maxson
CW4 Willard G. Maxwell
CPT David W. McDonald
WO1 Brenton T. McKinney
Mr. James R. McClin
Mr. Richard D. McLin
WO1 Brent A. Melland
WO1 Carlos A. Merino
LTC Roy L. Miller, Ret.
PFC Chad Moore
CW2 Daniel J. Mordarski
WO1 Gary T. Murphy
CW2 Dennis L. Niles
WO1 James A. Nix
2LT John A. Ochwall
1LT Jennifer J. Odum
2LT Brian K. Orwig
WOC David M. Paoiucci
WO1 Paul K. Paradis
WO1 Daniel J. Paulson
2LT James F. Peterson
2LT Todd K. Pettingill
WO1 Larry E. Philmalee
Mr. Michael E. Phillips
WO1 Keith A. Pieper
2LT Steven M. Pierce
2LT Gretchen B. Platt
1LT Kevin S. Poates
WO1 Bradley S. Podner
Mr. James Ponce De Leon
WO1 John E. Pool
WO1 Charles Edward Powell

2LT Edward Pregana
2LT John W. Priddy
WO1 Kenneth J. Quinlan
WO1 Juan C. Quintana
2LT Charles R. Rambo
WO1 Brad E. Ramspott
2LT John W. Reardon
2LT Paul M. Reeb
Ms. Melissa Reese
CW3 John F. Reid
WO1 David B. Richardson
CW3 James N. Richman, Jr.
CW4 Aaron D. Rick
WO1 Steven B. Riddle
2LT John D. Ring
2LT Alvaro F. Roa
2LT Terry J. Rodesky
LTC Lenear Royer III
Mr. Alfred Saliba
CW4 Edwin L. Sapp
WO1 Terri Terrell Savala
2LT Kristen A. Schindler
2LT Dominic M. Scola
WO1 Joseph E. Scott
2LT Kevin D. Settle
WO1 Erik W. Severino
WO1 Michael W. Sheffield
CPT Steven R. Shields
WO1 Jason P. Spangler
2LT Jason M. Squitieri
WO1 Scott R. Stever
2LT Brian C. Stehle
WO1 Steven R. Stein
WO1 Paul D. Straka
1LT Laurie A. Styloski
MAJ Christopher C. Sullivan
WO1 William J. Sutherland
1LT Carlos Tamez
2LT Chad B. Taylor
2LT Corey M. Tejohma
Mr. William C. Thomas
WO1 Silyn A. Thompson
WO1 Kerry J. Tillman
2LT Peter B. Tingstrom
2LT Marcea A. Tobolt
WO1 Otis Travers
WO1 Troy C. Trenholm
WO1 Stephanie K. Truxan
WO1 Brendan M. Tucker
2LT Todd J. Tuttle
2LT Kevin C. Tyler
Ms. Anice C. Vleck
2LT Christopher J. Walker
SGT George S. Walker
CPT William E. Walker
2LT Daniel R. Waters
CW2 Charles P. Watson
2LT Keith D. Wheeler
SGT Ronald S. Whetstone
WO1 Shay R. Williams
2LT Michael J. Wilson
2LT Kevin P. Wimberly
2LT David E. Wojczynski
WO1 Adam S. Worthington
1SG Harold K. Wurick
Mr. Frank A. Wynne
CW2 Brian M. Yoder
WO1 Mark J. Zerangue

**BAVARIAN
HOHENFELS, GERMANY**
SPC John F. Broom

**BLACK KNIGHTS
WEST POINT, NY**
Cadet Todd E. Buhr
Cadet Spencer J. Clouatre
Cadet Todd J. David
Cadet Joseph A. Dunlop
Cadet Eric A. Guttomson
Cadet Jon D. Kerr
Cadet Paul J. Maggiano
Cadet Andrew J. Norton
Cadet P. Peter Orabona
Cadet Andrew D. Rieger
Cadet Deirdre Spence
Cadet James R. Wynkoop

**CEDAR RAPIDS
CEDAR RAPIDS, IOWA**
SSG Allen D. Irwin
Mr. Harold G. Tiedeman

**CENTRAL AMERICAN
FT. CLAYTON, PANAMA**
CPT Richard A. Bucher
CW4 Michael D. Spradling

**CENTRAL FLORIDA
ORLANDO, FL**
CPT Cecil N. Bassham, Ret.
Ms. Bea Brashhear
Mr. Roger S. Busch
Mr. John F. Donahue, Ret.
CPT John D. Gottfried
LTC James B. Leahy, Jr.
Mr. David A. Miller
Mr. Gary G. Palmer
Ms. Joyce A. Pullin
Mr. James M. Skurka
LTC William R. Szymanski, Ret.
Ms. Donna L. Tucker

**COLONIAL VIRGINIA
FORT EUSTIS, VA**
PV2 Jeremy D. Beejman
PV2 Tracy L. Benjamin
PV2 Michael L. Brown
PV2 Lawrence M. Bryant, Jr.
PV1 Lisa K. Davis
PV2 Chad D. Earhart
PVT James P. Everhart
PVT Alisha L. Ferguson
SSG Gaspar Garrido
PV1 Luis Gonсалves
PV2 William C. Heine
PV2 Claudia Hernandez
PV2 William P. Hutto
PVT Louis Damon Knight
SPC Richard Donald Martin, Jr.
PV2 Jason J. Novak
SFC Michael G. Postell
PVT Patrick D. Robertson
PV2 Douglas M. Scalzo, Jr.
CW5 Karl H. Schmidt
PV2 Elizabeth A. Smith
PVT Michelle A. Tucker
Mr. Martin F. Walsh
PV2 Glen A. Waters
PV2 Mitchell C. Watson
PVT Michael J. Wiktorowicz
PV2 George M. Zeinert

**CONNECTICUT
STRATFORD, CT**
Mr. Peter A. Fleury
Mr. William H. Harper

Mr. Rufus A. James
MAJ Allen D. Sakriska
Ms. Kimberley L. Schmidt

**CORPUS CHRISTI
CORPUS CHRISTI, TX**
SFC William F. Brothers
SPC Michael L. Donner
SPC Richard E. Edwards
Mr. John Epperson
Mr. Donnie R. Evans
SGT Carl L. Fuss
Ms. Holly E. Gifford
SGT Brett W. Hayes
LTC Norman M. Hoover
Ms. Rita P. Lozano
Mr. Harry D. McAllister
Ms. Karen M. McEntire
SPC Brian A. McFarland
SGT Roberto Rodriguez
Mr. Jose Sanchez
Mr. Julian Zamudio, Sr.

**DELAWARE VALLEY
PHILADELPHIA, PA**
Mr. Joseph H. Schmid

**EDWIN A. LINK MEMORIAL
BINGHAMTON NY AREA**
Mr. Ralph P. Hampp
Mr. Charles J. Harris, Jr.
Mr. William E. Kahn
Mr. Larry Singleton

**FROZEN CHOKEN
GRAND FORKS, ND**
Cadet Brent J. Gomez

**GREATER ATLANTA
ATLANTA, GA**
LTC Morris D. Anderson, Ret.
CPT Jonathan F. Angeles
Mr. Fred W. Bowen
Mr. Martin B. Hammell
CW3 Steven E. Johnson
COL Donald M. Kollarik
Mr. Brian K. Overy
Mr. Lou A. Roberts
CW3 Ross Steadman
Mr. William W. Vaughan

**GREATER CHICAGO AREA
CHICAGO, IL**
LTC Michael A. Bendas
SGT Eric J. Blakely
SSG Michael J. Frantz
SGT Keith E. Hermann
SGT Ronald C. Jacobs
SFC Scott L. Lawrence
SSG Robert Negrete, Sr.

**HIGH DESERT
FORT IRWIN, CA**
CW3 Michael A. Lococo
MSG Paul B. Madrazo
CPT John M. McHugh
CW3 Lawrence Mercillott
CPT Jerald L. Phifer
2LT Dean D. Wegner

**HUDSON-MOHAWK
ALBANY, NY**
1LT Patrick T. Bacher
CPT Timothy W. Kelly
SFC Donald E. Roy

**INDIANTOWN GAP
INDIANTOWN GAP, PA**
Mr. Scott A. Harbarger
CW4 William Johns
COL Charles E. Martin
CW5 Reed M. Zellers

**IRON EAGLE
HANAU, GERMANY**
CPT Brendan P. Doran
SPC James E. Ford
CPT Robert E. Sanders, Jr.
Mr. Harvey L. Stolp

**IRON MIKE
FORT BRAGG, NC**
CW3 Dwight A. Bresemann
SGT Michael R. Conniff
2LT Andrew M. Patterson
1LT Chad Pruitt
SPC Bobby W. Reece

**JACK H. DIBRELL (ALAMO)
FORT SAM HOUSTON, TX**
LTC Ronald V. Racinevski

**LEAVENWORTH
FORT LEAVENWORTH, KS**
CPT Kevin L. Bricker

**LINDBERGH
ST. LOUIS, MO**
Mr. James E. Branca
MAJ Larry A. Carpenter
LTC Tzu-Shan Chang
CPT Anne R. Daugherty
Ms. Clarence Davis
2LT Edwin P. Grimsmer
CW2 Bradley G. Hurst
Ms. Florence Murphy
2LT Richard J. Velloff
Cadet Pete A. Zavitz

**MacARTHUR
NEW YORK/LL AREA, NY**
2LT Kurt J. Krummenacker
SGT Curt J. Napanaro

**MID-AMERICA
FORT RILEY, KS**
1LT Jon R. Gerold
CW3 Douglas C. Hettler
CW2 Chris W. Holland

**MONMOUTH
FORT MONMOUTH, NJ**
Mr. John F. Candage
Mr. Wayne R. Rickard
Ms. Nancy M. Toth
Mr. John Waters

**MORNING CALM
SEOUL, KOREA**
CW5 Randy L. Nielson
COL William J. Teltu

**NARRAGANSETT BAY
N. KINGSTOWN, RI**
SPC James Casala
Sergeant Joseph S. Hyde
1LT Sean P. McLerman
1SG James A. Mello
SPC Louis A. Netto, Jr.
SSG Ronald Edward Roscoe

**NORTH COUNTRY
FORT DRUM, NY**

CPT Mark E. Black
CSM Gabriel Villasenor

**NORTH TEXAS
DALLAS/FORT WORTH**
COL Thomas L. Beak, Ret.
COL Linwood E. Blackburn, Ret.
Mr. Robert E. Dodds

**NORTHERN LIGHTS
FORT WAINWRIGHT/
FAIRBANKS, AK**
2LT James M. Wenner

**OLD TUCSON
MARANA, AZ**
CW2 Richard R. Casper
Mr. William T. Craven
Ms. Kirsten L. Obedahl

**OREGON TRAIL
SALEM, OREGON**
SPC Mary L. Anderson
CW4 James M. Coleman
COL John M. Currie
CPT Ben W. Davidson
SFC Timothy J. Delgrosso
Mr. Bernhard Donner
Mr. Joachim J. Lehner
CPT Jeffrey R. Linscott
Mr. John Wells

**PHANTOM CORPS
FORT HOOD, TX**
CPT David Bogges
CW2 Joseph A. Carpenter, Jr.
MAJ Barry L. Cole
1LT Charles J. Dalcourt, Jr.
CW3 Patricia A. Deckard
CW2 Scott W. Dibble
CW2 Richard C. Diekmeyer
CPT Samuel E. Lamb
CW2 Jeffrey M. Lee
WO1 Jason M. Lonergan
CPT Colleen M. McAleer
CW3 Willard Monserrate
CW2 Jaye Rathbun
CPT Ryan B. Rydalc
CW2 Blaine Standford
CW2 Jose E. Tejada
SPC Lawrence H. Washington
CW4 Ken Wuest, Ret.

**PIKES PEAK
FORT CARSON, CO**
CW2 Victoria A. Welch

**POTOMAC
ARLINGTON HALL STN, VA**
CW5 Gary J. Eisenbraun
LTC William P. Gillette, Ret.
COL John D. Hathcock, Ret.
Mr. John F. Kutcher, Sr.
MAJ James F. Mulvehill
SSG Pamela L. Shughart

**RAGIN' CAJUN
FORT POLK, LA**
SFC James D. Shelton
WO1 Robert J. Smith

**RAZORBACK
NORTH LITTLE ROCK, AR**

Mr. John A. Pearson

**RHINE VALLEY
MANNHEIM, GERMANY**
SFC Edward D. Davis
SGT Fred Grimes
SPC Anthony W. Johns
CPT Doreen Y. Morris
CW5 James M. Pranger
CPT Zachary A. Randall
SSG Charles C. Salas
CPT Kevin R. Smith
SPC Ronald G. Taylor
SGT David K. Waters
1SG Anthony W. Wells

**SAVANNAH
FT STEWART/HAAF, GA**
SPC Larry B. Adams
CPT Ross Barner
2LT Ronald R. Harness
CW4 John C. Robb, Ret.
CW2 Richard H. Tanner
1LT James A. Walsh

**SOUTHERN CALIFORNIA
LOS ANGELES, CA**
MAJ Steve J. Countouriotis
LTC Larry W. Moss
Mr. John Peebles
Mr. Richard A. Rittenhouse

**TALON
ILLESHEIM, GERMANY**
SSG Stephen L. Bush
SGT Joe Carroll
Mr. Brian C. Dahlin
1SG Ricky L. Dinsud
SPC Richard S. Dix
SGT Richard W. Fee
CW3 Michael G. Hafkemeyer
PFC Theodore J. Hanna
CW3 James F. Jones
PFC Raymond L. Kachemeyer
CPL Sean L. Kator
SPC Kendra C. Leirer
CW2 Robert G. May, Jr.
PFC Paul Alvin Mertens
CW3 John S. Murphy
SSG Timothy L. O'Neal
SPC Robert J. Parker
SPC Lucce E. Piro
CSM David B. Rabon
PFC Daniel W. Rakjaski
SFC Miles M. Sewash
SFC Ronnie A. Souder
1SG Jephtha I. Tuten
SPC David E. Vasquez
SFC Steven R. Vogt
SPC James D. Wells

**TAUNUS
WIESBADEN, GERMANY**
CPT Charles S. Cason
SFC Edgar H. Cherry
SSG Paul M. Flores
SFC Robert S. Long
CPT Joni K. Matthews
SFC Daniel J. Nason

SFC Kayla J. Nason
SSG Mark E. Sewell
1LT Kenneth J. Verhulst

**TENNESSEE VALLEY
HUNTSVILLE, AL**
Mr. Robert I. Brock
MAJ Willie D. Brunetti, Ret.
Mr. William L. Copeland
Mr. George E. Vinson

**WASHINGTON DC
WASHINGTON, DC**
Mr. Alfed F. Barrett
Mr. Paul T. Blue
SFC Karen A. Carter
Mr. Robert F. deGrandcourt
LTC Buryl E. Dooley
2LT Matthew R. Edmond
CW3 Clifton D. Fleming
CPT Kenneth E. Heller, Jr.
SSG Melinda L. Hender
CW5 James A. Hildreth
Mr. Ben F. Hord, III
Mr. Robert W. Iler
COL Johan G.C. Klemeny
Mr. Seth Leyman
Ms. Kimberly J. Lyons
Mr. John McMunigal
MAJ Roberta Mustico
SFC William Phipps
CW4 Gil H. Robertson
Mr. Edward Rodemsky
Mr. Robert G. Ross
SPC Michelle J. Salvador
Mr. John David Schimmel
SGT Paul J. Schreiffels
Mr. F. William Smullen
2LT Ivette Solo
CW4 Major E. Weber

**WESTERN NEW YORK
ROCHESTER, NY**
Mr. Ken P. Leighton

**WINGS OF THE MARNE
ANSBACH, GERMANY**
1LT(P) Mikael R. Ash
CPT Michael J. Bradley
CW2 Andrew C. Cranford
SFC Richard L. Davis
1LT Cindy M. Doane
CPT Carl S. Ey
CW3 Michael W. Garret
CW2 William P. Gordon, Jr.
CW3(P) Thomas J. Hitchcock
CW2 Stephen E. Hunnycutt
SFC Eugene Jeffers
CW3 John E. Kinsaul
2LT Steven C. Payne
CW3 Steven W. Shockney
CPT Miracle D. Solley
CPT Michael S. Sturgeon
CW2 Brian K. Twigg
1SG Brian D. Van Wagner
1LT Scott T. Williams
CPT Bruce Zartman
**MEMBERS WITHOUT
CHAPTER AFFILIATION**
Mr. Harry R. Allen, Jr.

1LT Anthony Barber
MAJ Danny P. Bolinott
2LT Reid S. Brewer
PFC Olivia J. Bryuere
MAJ James R. Burns
Ms. Barbara J. Cameron
Cadet Andrew T. Carter
CW4 Paul Q. Carter
CW3 Billy J. Clark
CW4 John A. Clark
Mr. Wade E. Cuthbertson
CW2 Christopher M. Delao
Cadet Ron T. DeMott
Mr. Jean P. Etchevery
COL George B. Faulhaber
2LT Craig W. Fellman
Mr. Henry Geraeds
Mr. Jan Gillin
Mr. Bruce Goldetsky
COL Bill J. Gollieb, Ret.
Cadet Eugene J. Gregory
CW4 John R. Hagan
Cadet David L. Hall
LTC Jerry W. Hall
CW3 Stephen F. Hammons
CW2 Dana J. Heimdahl
CPT Dale R. Hiller, Ret.
CW3 Timothy R. Houck
CW4 Richard Terry Hulstey
Mr. George A. Humphrey
SSG Aldric M. Hunter
Cadet Christopher Kessal, Jr.
CPT Paul M. Kelly
SGT Robert H. Kline, Ret.
Mr. William A. Knapp
2LT Cornelius W. Kugler
BG O. Armagan Kuloglu
Ms. Susan J. MacMahon
S-A Thor Marlinsen
Ms. Janet L. Mason
Ms. Michelle McDermott
Mr. Randal Gordon McGillis
LTC Richard Bryan Melchior
Mr. Ray Millaway
CPT Christopher L. Miller
2LT Byron R. Mobley
Mr. Joseph R. Moore
CW4 Dale L. Morris
PFC Jon C. Morvant
SGT Scott D. Nelson
Mr. Ronald W. Oates
WO1 Chad R. Owens
Mr. Anthony Peters
CW4 James B. Robinson
SGT Carole A. Rowland
Dr. James Scudder, Ret.
MAJ Robert M. Spillers
MG Ching-Sheng Sun
2LT Robert J. Thompson, Jr.
Mr. Scott Thomsen
COL Gordon D. Toney
COL Chien-Cheng Tung
WO1 Marquel T. Underwood
CPT John W. Villacres
CPT Dennis C. Walburn
Mr. Bill Walters
Cadet G.G. Waltz
MAJ I-Yao Wang
Mr. Ken Woolnough
BG Frederick A. Zehrer III Ret.

AAAA President's Message

By

MG Richard E. Stephenson, Ret.

This constitutes my first opportunity to address you as the President of your association. I hope to make this a regular feature throughout my term to keep you informed on events, issues, and initiatives we are pursuing to meet the vision, goals and objectives that have been established to better serve the needs of all our members.

First of all, I'd like to thank Ben and Carolyn Harrison for two outstanding years of leadership of the AAAA. Dianne and I look forward to building on their successes.

The recently completed convention was a resounding success by almost every measure. Although exhibit revenue was down significantly, I feel we held our own in the face of a pretty tough fiscal environment, and would like to thank all our AAAA Corporate members for their support.

Force structure reductions, the BRAC, and industry consolidations are all part of the Army Aviation picture right now. But amazingly enough, so is a stable and slightly growing AAAA over the last eight years, a fact that no other military association I am familiar with can claim.

Whether it's dumb luck, hard work, or just being in the right branch at the right time, Army Aviation by virtue of its flexibility, versatility, and ability to develop devastating combat power over thousands of miles in hours not weeks, stands on the verge of what I believe is a golden age.

With the situational awareness capability of Comanche which we have just seen rolled out and the lethality of the Longbow Apache, the potential for more efficiencies in mission planning, automated maintenance, simulation and logistics, I see us at a threshold not a plateau.

Your association has never been more important to the future of Army Aviation nor in a stronger position financially and in membership to influence the results.

In future articles I will be sharing the findings of the Strategic Planning Committee of the National Executive Board and asking for your comments.

I encourage you to continue to share your thoughts at any time on how we can continue to improve through our various ongoing surveys as well as just dropping me a line in care of the National Office or E-Mailing us at 74023.3400@compuserve.com.

Awards and Honors

The AAAAA provides awards to the Distinguished Graduates of the Initial Entry Rotary Wing Aviator Course and certain enlisted, warrant officer, and officer courses at Ft. Rucker, AL and Ft. Eustis, VA that have been determined by the AAAAA Aviation Center Chapter's Executive Council to merit a Distinguished Graduate Award. The information below is provided and the awards are coordinated by the respective local AAAAA Chapter's VP of Awards.

Aviation Warrant Officer Basic Course, Class 95-912 (7 FEB 95): Steven S. Black, Kurt M. Gruner, Jessie P. Scruggs, Larry A. Staley, Dist. Grads, WOBC; Silas E. Bland, Jr., Michael D. Kelley, Shawn A. Bainbridge, Christopher S. Burns, Dist. Grads, IERW.

Aviation Officer Basic Course, Class 95-902 (16 FEB 95): Clinton J. Conzemius, Dist. Grad, AOBC; Brett J. Rota, David B. Ladzick, Mitchell G. Johnson, Dist. Grads, IERW.

Aviation Officer Advanced Course, Class 95-1 (23 MAR 95): CPT Terrell C. Boyd, Dist. Grad.

Aviation Officer Basic Course, Class 95-903 (30 MAR 95): Michael A. Keegan, Dist. Grad, AOBC; David G. Rader, II, Dist. Grad, IERW.

Aviation Warrant Officer Basic Course, Class 95-2 (5 APR 95): John A. Weisbeck, Dist. Grad, WOBC & IERW; John A. Erickson, David A. Januzelli, Kenneth M. Lazorchak, Robert A. Pelkey, Michael L. Wesolek, Dist. Grads, WOBC; Kevin M. Drew, Richard T. Nameniuk, Larry E. Philamalee, Jr., Dist. Grads, IERW.

Aviation Warrant Officer Basic Course, Class 95-3 (3 MAY 95): Kimberly A. Gandee, Dist. Grad, WOBC; John S. Ault, Bradley R. Elefson, Dist. Grads, IERW.

Aviation Officer Basic Course, Class 95-904 (11 MAY 95): 2LT Peter B. Tingstrom, Dist. Grad, AOBC; 2LT William B. Bradley, Dist. Grad, IERW.

Aviation Officer Advanced Course, Class 95-2 (26 MAY 95): CPT John P. Miller, Dist. Grad.

AAAA AEC Symposium Set

The 13th Annual Aviation Electronic Combat (AEC) Symposium will be held at the Galt House Hotel, Louisville, KY, Oct 30-Nov 1, 1995. This year's theme is "Joint Aviation Electronic Combat". The 1995 Symposium is open to all interested AAAAA members and will NOT be classified this year. Contact the AAAAA National Office at (203) 226-8184 for Registration and Housing Forms.

Sponsored by Cubic Defense Systems, Inc., the AAAAA Avionics Award will be presented at the 1995 AEC Symposium to "the person who has made an outstanding contribution to Army Aviation in the area of Avionics during the awards period encompassing 1 August 1994 through 31 July 1995."

Sponsored by Loral Electronic Systems, the AAAAA Aircraft Survivability Equipment Award will also be presented at the 1995 AEC Symposium. It will be presented "to the person who has made an outstanding individual contribution to Army Aviation in the area of ASE during the awards period encompassing 1 August 1994 through 31 July 1995."

Contact the AAAAA National Office at (203) 226-8184 for official nomination forms. The suspense date is 1 September 1995.

Nominations Open

Nominations are now open for the AAAAA Army Aviation Fixed Wing Unit Award, sponsored by FlightSafety International, the AAAAA Army Aviation Medicine Award, sponsored by Gentex, the AAAAA Army Aviation Trainer of the Year Award, sponsored by Hughes Link Training, and the AAAAA Army Aviation Air/Sea Rescue Award, sponsored by Lucas Aerospace. These awards will be presented at the 10 January 1996 AAAAA Aviation Center Chapter Annual Award Banquet at Ft. Rucker, AL.

The awards period covers 1 September 1994 to 31 August 1995. Contact the AAAAA National Office at (203) 226-8184 for the official nomination forms and requirements. The suspense date for all nominations to be received at the AAAAA National Office is 30 September 1995.

WHEN WILL CW5 PAY BE AUTOMATED?

By CW4 Joseph L. Pisano, Ret.

*Former Chairman of the Aviation Warrant Officer Committee of the
AAAA National Executive Board*

Four years ago, Congress created the Chief Warrant Officer Five (CW5) rank for the U.S. Army.

As of this writing, all Defense Department agencies have adjusted their programs to include this rank, with the notable exception of the finance community.

I was finally able to track down the decision-making office at the Defense Finance Administrative System (DFAS) concerning that agency's delay in fully implementing CW5 into the automated pay and benefits structure.

The problem is in reprogramming an already extremely complicated protocol to accept the new rank pay structure with all the appropriate benefits under all situations. I spoke with Mr. Roger Koons, the branch chief at DFAS Systems Support Group in Denver, CO. His branch is responsible for implementing and debugging the programming changes. Mr. Koons' office has been working this problem since the inception of the new rank. They have gone as far as they can within his department's current budgetary constraints.

Because of the comparatively small number of personnel affected by this problem, Mr. Koons has been forced to allocate limited resources to other problems that have been impacting on a larger number of the population. As such, CW5 pay issues are being handled for the time being in a similar manner to general officer issues; that is, manually.

Armed with this information, I contacted Mr. Steve Williams, President of the DFAS Configuration Control Board in Cleveland, OH, which is the agency that sets the priorities and allocates the funding for Mr. Koons' department. Mr. Williams advises that the Board presently has the CW5 resolution project fully funded for fiscal year 1996.

So, if all goes as planned, the field should see CW5 fully up and running on DFAS sometime in the first half of the new year.

This article marks the beginning of a new regular feature for ARMY AVIATION. Periodically, articles will appear that address specific issues pertinent to the Aviation Warrant Officer. Members are encouraged to send issues and/or questions for this new feature to the Aviation Warrant Officer Affairs Committee, c/o Army Aviation Association of America; 49 Richmondville Avenue, Westport, CT 06880.

Coming next — the results of the AAAA Aviation Warrant Officer Survey.

New AAAA

Chapter Officers

Bavarian:

CPT Marxen W. Kyriss
(Secretary).

Central Florida:

LTC Arthur A. Marubbio,
Ret. (Pres); MSG Samuel
Richard, Ret. (VP,
Programming).

Edwin A. Link:

Rudolph T. Woolridge (VP,
Renewals).

High Desert:

MAJ Howard R. Ferguson
(SrVP); CW2 Jeffrey M.
Korentur (VP, Prog); CPT
James P. Cassella (VP,
Pub); MAJ Elizabeth J.
Higgins (VP, Mil. Aff).

Northern Lights:

CW4 Mike L. Johnson
(President).

Oregon Trail:

MG Raymond F. Rees
(Pres); MAJ Robert Payne
(SrVP); SFC Tim Del
Grosso (Treas); CW3
James O. Jackson (VP,
Memb); COL John Pierce
(VP, Associate Memb);
CPT Jeff Linscott (VP,
Publicity).

Tanus:

LTC Robert L. Berkstreser
(Treasurer).

AAAA Aviation Soldiers of the Month

A Chapter Program to
Recognize Outstanding
Aviation Soldiers on a
Monthly Basis.

PFC Matthew Giorgio
March 1995

Air Assault Chapter



Above: MG Richard E. Stephenson, Ret. (left), AAAA President, joins MG Ronald E. Adams (right), Aviation Branch Chief and CG, USAAVNC and Ft. Rucker, AL in presenting COL Stephen K. Cook (center), AAAA USAREUR Region President, with an Order of St. Michael Silver Award at the AAAA USAREUR Professional Day, 21 April 1995.

Below, left to right: Graduates of the 13 April 1995 OCS class pose for a photo. Bottom row: 2LTs Raymond Williams, Charles Forman, Paul White, Brent McDonald, and LTC William Bowers, Chief, Aviation Proponency, USAAVNC, Ft. Rucker, AL. Top Row: 2LTs Kerry McCauley, Richard Sweet III, Charles Byrd, Jr., and Michael Premo. Not pictured: 2LT Bratmiller and 2LT Frank Holmes. AAAA provided the newly commissioned officers with their first set of Aviation Branch insignia.





Above, left to right: Graduates of the 18 May 1995 OCS class gather for a photo. Bottom row: 2LT Darren King, 2LT Phillip Wadsworth, 2LT Robert Todd, and 2LT Christopher Swanson. Top row: 2LT Dudley Capps, 2LT Bryan Martyn, 2LT Leon Dodroe, and 2LT Rodel Pasibe. AAAA provided the newly-commissioned officers with their first Aviation Branch insignias.

Below: LTG Jerry R. Rutherford (fourth from left) was presented with an Order of St. Michael Silver Award on 24 March 1995 for his 32 years of military service and significant contributions to Army Aviation. Present for the ceremony were (left to right): COL Stephen K. Cook, AAAA USAREUR Region President, LTC Jerel Pawley, V Corps Deputy Aviation Officer, COL Roger Anglin, Commander, 12th Aviation Brigade, MG Walter H. Yates, DCG, V Corps, and COL Jack Bryant, Cdr, 11th Aviation Regiment.



SPC Robert J. Parker
March 1995
Talon Chapter

SPC Douglas J. Swails
April 1995
Talon Chapter

**New AAAA
Industry Members**
Navtrak, Inc.
Eugene, OR

**New AAAA
Sustaining Industry
Members**

B. Jon Vleck
Clockmaker, Inc.

Ozark, AL
City of Dothan, AL
Dothan, AL
City of Ozark
Ozark, AL

**Community Bank &
Trust S.E. Alabama**
Enterprise/Ft. Rucker, AL
Conagra Poultry Co.

Enterprise, AL
Econo Lodge
Daleville, AL
**McLin's Family
Restaurant**
Daleville, AL

Montgomery Aviation
Montgomery, AL
Pike Aviation
Troy, AL
**Sunshine Aero
Industries, Inc.**
Floral, AL

Thomas Technology, Inc.
Daleville, AL

In Memoriam
Mrs. Chrissie
Bunker Bullock
LTC Alvin F.
Burch, Ret.
COL William S.
Bayer, Ret.

AAAA CALENDAR

A list of upcoming AAAA Chapter and National events.

July 1995

- ✓ **Jul. 14.** AAAA Scholarship Board of Governors Executive Committee Meeting, National Guard Readiness Center, Arlington, VA.
- ✓ **Jul. 15.** AAAA National Scholarship Selection Committee Meeting to select 1995 scholarship recipients, National Guard Readiness Center, Arlington, VA.

October 1995

- ✓ **Oct. 16.** AAAA National Executive Board Meeting, Sheraton Washington Hotel, Washington, D.C.
- ✓ **Oct. 16.** AAAA Scholarship Board of Governors Executive Committee Meeting, Sheraton Washington Hotel, Wash., D.C.

December 1995

- ✓ **Dec. 9.** AAAA Morning Calm Chapter Christmas Ball, Seoul, Korea.

January 1996

- ✓ **Jan. 26.** AAAA Scholarship Board of Governors Executive Committee Meeting, National Guard Readiness Center, Arlington, VA.
- ✓ **Jan. 27.** AAAA National Award Selection Committee Meeting to select 1995 National Award recipients, National Guard Readiness Center, Arlington, VA.
- ✓ **Jan 31-Feb. 2.** Joseph P. Cribbins Product Support Symposium sponsored by AAAA Lindbergh Chapter & AAAA Logistics Support Unit Awards & AAAA Industry Award Presentations, Stouffer Concourse Hotel, St. Louis, MO.

March 1996

- ✓ **Mar. 27 - 30.** AAAA Annual Convention, Tarrant County Convention Center, Fort Worth, TX.
- ✓ **Mar. 27.** AAAA National Executive Board Meeting, Tarrant County Convention Center, Fort Worth, TX.
- ✓ **Mar. 28.** AAAA Scholarship Board of Governors Meeting, Tarrant County Convention Center, Fort Worth, TX.

CAREERTRACK • CAREERTRACK

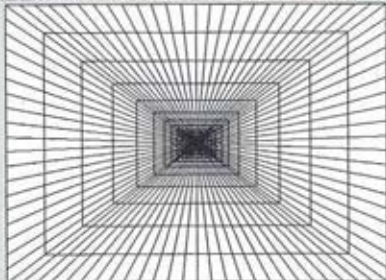

CAREERTRACK • CAREERTRACK

Active AAAA members may have a 30-word classified employment ad published in two consecutive issues of **ARMY AVIATION** free of charge.

If you'd like to take advantage of the AAAA CareerTrack employment referral service, but you're not yet a member of AAAA, the solution is simple. Request an AAAA membership application with your CareerTrack application.

For further information, contact:

AAAA, 49 Richmondville Avenue, Westport, CT 06880; Telephone: (203) 226-8184; FAX: (203) 222-9863.

Five years experience in manufacturing operations and marketing. Inventory control, safety, training, and personnel management. Airport commission member and municipal experience. B.S., MBA Marketing. Will relocate.

95-05-01

AAAA GOES ON-LINE!

The AAAA National Office now has E-Mail capability via CompuServe. Our address is:
74023.3400@compuserve.com



The digital battlefield

now includes HF
Nap-of-the-Earth
communication.

The U.S. Army specified the performance levels. Make it eyes-out, easy to learn and simple to use. It had to include high connectivity, with embedded automatic link establishment (ALE), data modem and electronic counter countermeasures (ECCM).

Rockwell's Collins Avionics & Communications Division delivered it all, including full digital signal processing, field programmable ADA software and a spare card slot. The AN/ARC-220 Nap-of-the-Earth (NOE) high frequency communications system is the result of a true partnership with the Army. We're proud to be able to place this technology in our soldier's hands.

In the U.S., call (800) 321-CACD (2223), outside the U.S., call (319) 395-5100, or fax (319) 395-4777.

Collins Avionics & Communications Division
Department 120-131 • Rockwell International
350 Collins Road NE • Cedar Rapids, Iowa 52498

 **Rockwell** Defense Electronics
Collins

NAVIGATION • COMMUNICATION • DATA LINKS • FLIGHT MANAGEMENT • SYSTEMS INTEGRATION

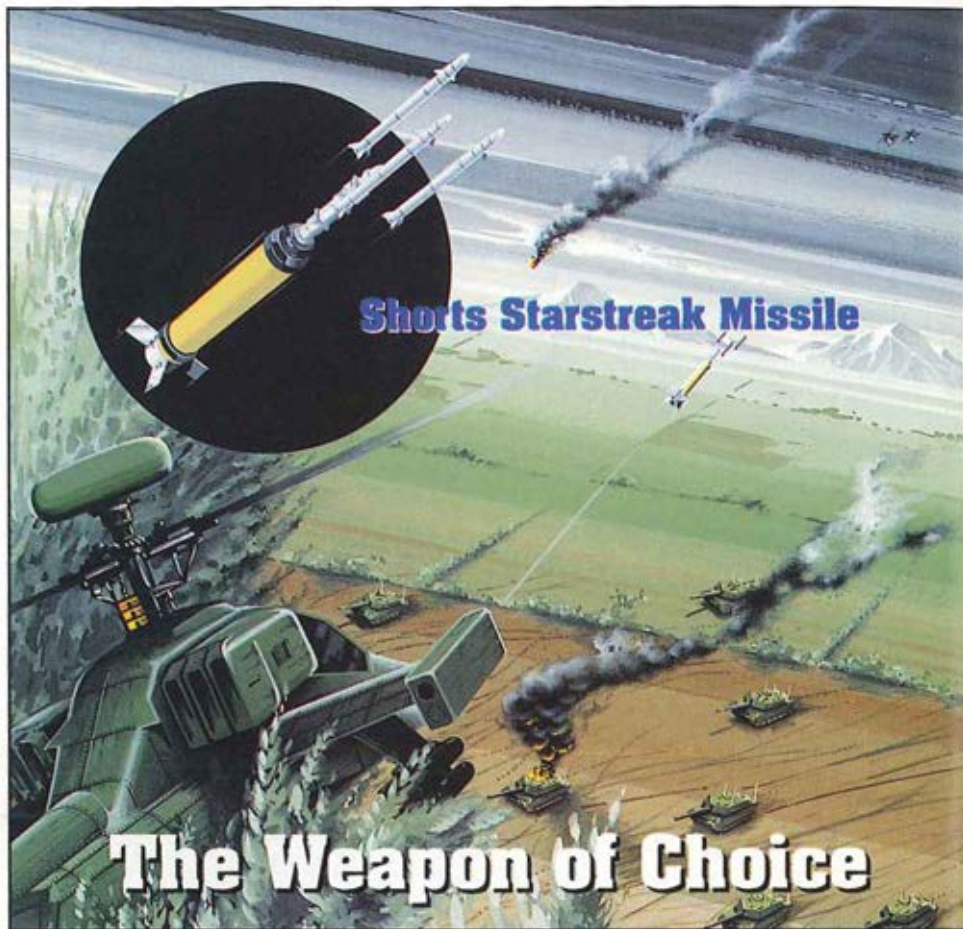

Shorts Starstreak Missile

The Weapon of Choice

Starstreak selected by U.K. as air-to-air weapon for attack helicopter program.

- Effective** ★ 3 warhead punch assures target destruction.
- Protective** ★ Quick prelaunch and missile velocity assure survivability.
- Collaborative** ★ Shorts teams with McDonnell Douglas, Martin Marietta and Westland.
- Economical** ★ Off-the-shelf and ready to go!

For more information, contact Short Brothers (USA), Inc.,
2011 Crystal Drive, Suite 713, Arlington, VA 22202-3719.
Or call us at (703) 769-8700.



SHORTS