

SPECIAL FOCUS: Command Control Communications and Intelligence (C³I)

FIELD REPORTS • Aviation agencies and units provide updates 10

AAAA • 1988 SPOOF Roster 19

AVIATION BRANCH • Update by MG Ellis D. Parker, Branch Chief 3

ARMY AVIATION

ENDORSED PUBLICATION OF THE ARMY AVIATION ASSOCIATION OF AMERICA • DECEMBER 31, 1988

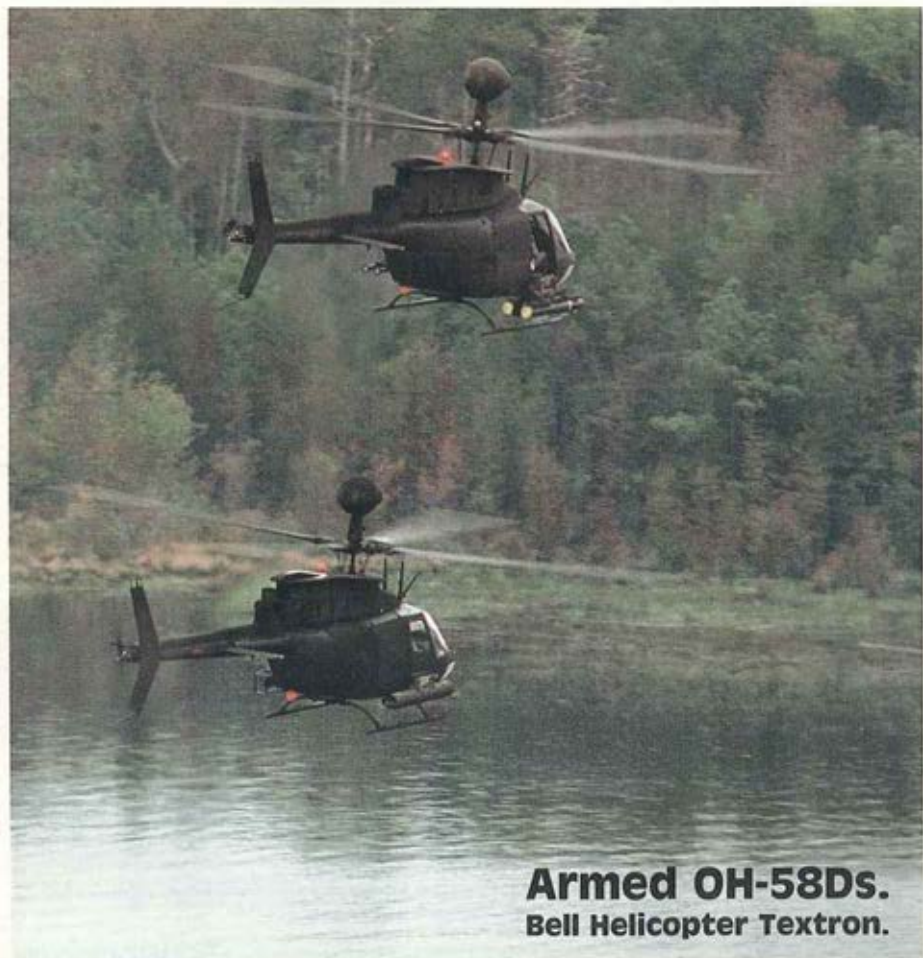

**Armed OH-58Ds.
Bell Helicopter Textron.**

PUBLISHER

Lynn Coakley

**ASSOCIATE PUBLISHER
& ADVERTISING DIRECTOR**

Terrence M. Coakley

EDITOR

William R. Harris, Jr.

PRODUCTION MANAGER

Joanne M. Corncheck

EDITORIAL/PRODUCTION ASSISTANTS

Debbie Melsinger, Joan Zinsky

CIRCULATION MANAGER

Jill Thomas

CIRCULATION ASSISTANTS

Mary Ann Stirling, Debbie Coley, Nancy Childs

Army Aviation Magazine is a professional journal endorsed by the Army Aviation Association of America (AAAA).

ADVERTISING

Display and classified advertising rates are listed in SHDS Business Publications, Classification 90. For advertising information, call (203) 226-8184.

SUBSCRIPTION DATA

ARMY AVIATION (ISSN 0004-248X) is published monthly, except April and September by Army Aviation Publications, 49 Richmondville Avenue, Westport, CT 06880-2000. Phone: (203) 226-8184 and (203) 226-8185. Subscription rates for non-AAAA members: \$25, one year; \$48, two years; add \$10.00 per year for foreign addresses other than military APO's. Single copy price: \$3.00.

ADDRESS CHANGES

The receipt of change of addresses is verified by the publication of the residence or business change in the "Arrivals & Departures" or PCS columns of the magazine. Senior AAAA members (O-6's and above) are asked to provide their new duty assignment for publication in the magazine's "Aviation Command Changes" column.

POSTAL

Second class postage paid at Westport, CT.

POSTMASTER

Send address changes to Army Aviation Publications, 49 Richmondville Ave., Westport, CT 06880-2000

FORTHCOMING ISSUES

January 1989 — Special Report: U.S. Army Avionics Research and Development Activity (AVRADA)

February 1989 — Special Focus: Rotary and Fixed Wing Hardware Update by PMAs.

FRONT COVER

Paid advertisement:
Bell Helicopter Textron's Armed OH-58Ds on maneuvers at Fort Bragg, NC

ARMY AVIATION

VOLUME 37

NUMBER 12

AVIATION BRANCH UPDATE**C²I in Army Aviation**

by Major General Ellis D. Parker.....3

AAAA NEWS

AAAA — 1988 SPOOF Roster.....19

AAAA — ASE Symposium Report.....62

SPECIAL FOCUS: C²I**C²I Combat Developments and Training**

by Major Peter M. Bartosch.....6

C²I Integrated Avionics

by James M. Burwell.....7

FIELD REPORTS**Congressional Authorization Support**

by Major General Charles E. Dominy.....10

Record Set in Aviation Safety

by Colonel (P) Marvin E. Mitchiner, Jr.11

Update: Department of Combined Arms Tactics

by Colonel Malvin L. Handy.....12

U.S. Army School of Aviation Medicine

by Lieutenant Colonel David J. Wehry, MS, SFS.....14

What is NET?

by Sergeant Major Joseph W. Jordan.....15

ARNG Safety Update

by Colonel John J. Stanko, Ret.....16

Armed OH-58D: Status Report

by Colonel James R. Cox.....18

U.S. Precision Helicopter Team Wants You

by CW4 E. Daniel Kingsley.....48

OTHER DEPARTMENTS

Awards and Honors.....56

Briefings.....56

Career Track.....55

New Members.....59

PCS.....57

EDITORIAL MATERIAL

The views expressed in the magazine are those of the individual author and may not necessarily be those of the department of the Army or the staff of this publication. Manuscripts, drawings, photos, and other material cannot be returned unless accompanied by a stamped envelope bearing the submitter's return address.



C³I in Army Aviation

by Major General Ellis D. Parker, Chief,
Aviation Branch and Commanding General,
U.S. Army Aviation Center and Ft. Rucker, AL

To paraphrase Air Chief Marshal Sir Peter Harding of the Royal Air Force, the basic requirement of a Command, Control, Communications and Intelligence (C³I) system is that it must enable the commander to do the following: (1) gain early warning of attack, (2) analyze from that warning the nature of the threat or threats in priority order, (3) marshal and order forces to ensure that they are in the right place at the right time and in the right numbers, and (4) evaluate the success or failure of his plan, of his commanders, and of his men continuously until the engagement is over. Also highly desirable is a fifth element, which consists of the commander's being able to bring an informed and immediate influence to bear on all areas of a military operation.

Historical Perspective

While recognizing that improvements in C³I tend to be closely followed by increasingly effective countermeasures, we must continue striving to consistently achieve all of these C³I elements.

Although the term C³I is of recent vintage, the functioning or malfunctioning of its various elements is as old as organized human societies. While the summary executions of hapless bearers of unwelcome intelligence in some ancient societies were probably far less frequent in fact than in legend, these messengers nevertheless constitute good early historical examples of C³I in operation. So also does the equally unfortunate first marathon runner, Pheidippides, who dropped dead of natural causes after delivering to the Athenian leaders the (in this case *welcome*) news of the Athenian victory over the Persians at the village of Marathon in 490 B.C.

A later occasion which exemplifies the malfunctioning of the C³I process was the Battle of Balaclava during the Crimean War. During that battle, a hastily written order to Lord Cardigan occasioned the C³I imbroglio and the consequent catastrophe for the British Cavalry brigade which Alfred Lord Tennyson memorialized in the "Charge of the Light Brigade." The Iranian hostage rescue mission, the Grenada operation, and the two unfortunate incidents involving the U.S. Navy in the Persian Gulf might be cited as more recent examples of problems with the C³I process.

Modern C³I

Within the U.S. Department of Defense, command, control, and communication (C²) have been combined with intelligence since 1977 to ensure the development of systems that met the operational needs of forces in the field.

Then in 1984, Congress established the position of Assistant Secretary of Defense for C³I (ASD[C³I]). This office has promoted improvements in hardware and system acquisition and also increased C³I interoperability among the branches of the U.S. military and between the U.S. and its allies. A Joint Chiefs of Staff study of July 1987 and an Office of the Secretary of Defense report of October 1987, however, caused Congress to consider legislation to separate intelligence from C².

As finally passed in Congress in 1988, this legislation revokes the specific statutory requirement for an assistant secretary with the combined functions of C² and intelligence and also requires the Office of the ASD to review the question of separation of these functions and report
(C³I — continued on page 54)

| Team Member | LHX Role(s) | Applicable Experience |
|---------------------------|--|--|
| Boeing Helicopters | Team co-leader; avionics system integrator; Integrated Logistics Support management. | Design, development, production and management of large-scale weapon systems including CH-47, V-22; R&D programs including Model 360, Advanced Digital Optical Control System (ADOCS). |
| Sikorsky Aircraft | Team co-leader; air vehicle integrator; simulation management. | Design, development, production and management of large-scale weapon systems including UH-60, SH-60, H-53; R&D programs such as Advanced Composite Airframe Program (ACAP). |
| Boeing Military Airplanes | Mission Equipment Package (MEP)/avionics system integrator. | B-1B, B-52 and Advanced Tactical Fighter (ATF) avionics integration. |
| Boeing Electronics | Flight control computer. | Sea Lance, SRAM II, ADOCS, V-22, 737, 747, 757, 767 flight control computers. |
| Collins Avionics | Integrated Comm/Nav/Ident., Avionics (ICNIA); multifunction displays and controls. | ICNIA developer for A-12 Advanced Tactical Aircraft P ³ and ATF. |
| GE Armament | Lightweight turreted gun system. | High-rate-of-fire weapon and ammunition handling systems; AH-1 Cobra turret system; helicopter air-to-air effectiveness studies. |

THE FIRST TEAM. THE

Unequaled skills, systems management experience

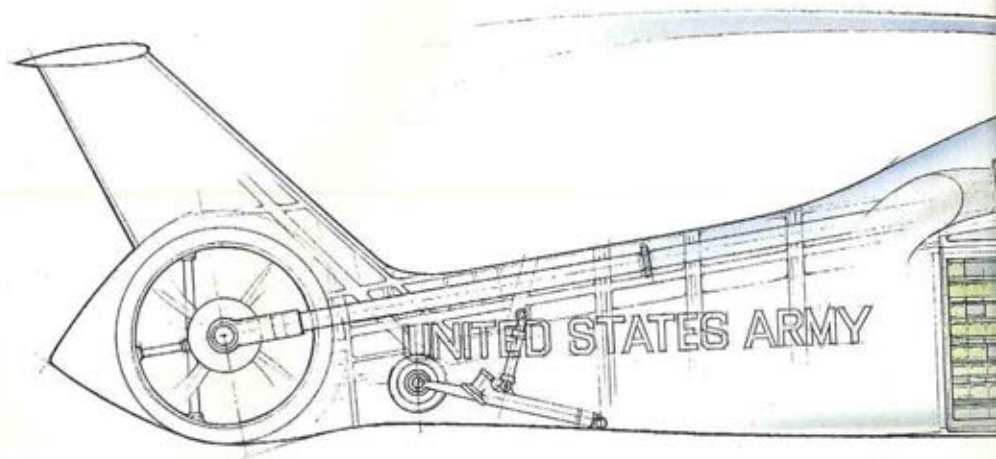

| Team Member | LHX Role(s) | Applicable Experience |
|------------------------|--|---|
| Hamilton Standard | Flight control computer; Wide-Field-of-View Helmet Mounted Display system (HMD). | UH-60, SH-60, H-53, X-Wing and ATF flight controls development; Army infantry helmet display. |
| Harris | 3-D digital map display; super high-speed data bus; sensor data distribution network. | Digital map displays for F-16, Fiber Optic Guided Missile (FOG-M), A-12 and ATF; common modules for A-12 and ATF. |
| Kaiser Electronics | Wide-Field-of-View Helmet Mounted Display system (HMD). | "Agile Eye" HMD; AH-1W full-function symbol processor; helmet tracking system integration for SHADOW research helicopter. |
| Link Flight Simulation | Operator training systems. | AH-64 Combat Mission Simulator (CMS); AH-1, UH-60 simulators; C-130 turnkey Aircrew Training System (ATS). |
| Martin Marietta | Electro-Optic Target Acquisition/Designation System (EOTADS); radar. | TADS/PNVS for AH-64; Airborne Adverse Weather Weapons System (AAWWS) co-developer; LANTRN; Standardized Infrared Sensor (SAIRS). |
| TRW | VHSIC-based signal and data processors; ICNIA; Aircraft Survivability Equipment (ASE). | ICNIA developer for A-12 P ¹ and ATF; ATF common signal processor; Integrated Electronic Warfare System (IEWS) co-developer. |
| Westinghouse | VHSIC-based computers; EOTADS; radar; ASE. | AAWWS co-developer for AH-64; F-16 VHSIC programmable signal processor; F-16 and B-1B radar; IIEWS co-developer. |

BEST TEAM FOR LHX.

and technologies for the U.S. Army's LHX program.

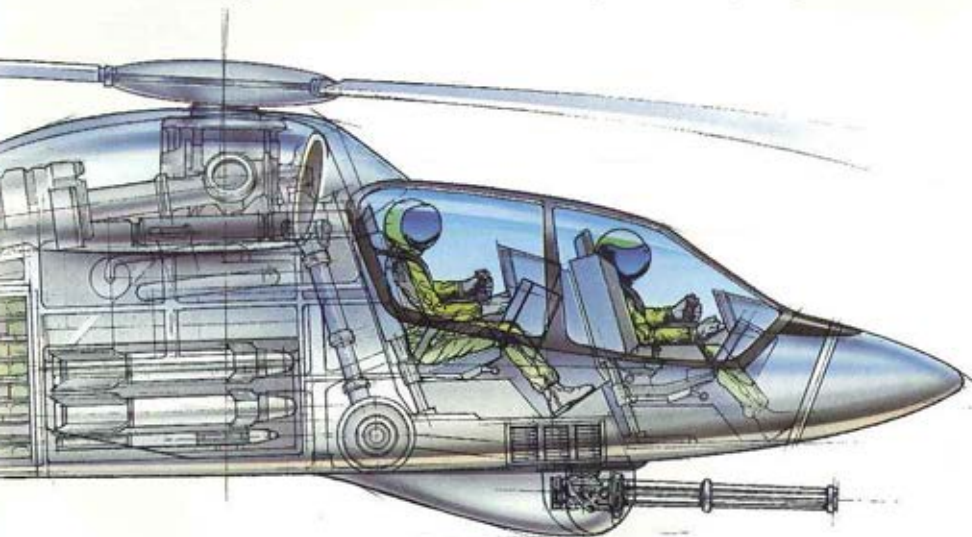

BOEING SIKORSKY
THE FIRST TEAM FOR LHX

Boeing Helicopters • Sikorsky Aircraft • Boeing Electronics • Boeing Military Airplanes • Collins Avionics • GE Armament • Hamilton Standard • Harris • Kaiser Electronics • Link Flight Simulation • Martin Marietta • TRW • Westinghouse



C³I Combat Developments and Training

by Major Peter M. Bartosch

This is the age of the largest, most prolific fielding of new communications equipment ever seen in the free world. The numbers indicate there will be one communications device for every square kilometer in Europe upon completion of this fielding.

What has prompted DoD to make such a staggering investment in communications? Why is there such a demand for frequency hopping, spread spectrum, undetectable, securable communications equipment? The answers are as old as war itself, the insatiable need for instantaneous acquisition, classification, engagement and assessment systems impervious to enemy interference that give the commander the decisive edge on the battlefield.

A Review of the Systems

Let's review some of these systems so we can get a better understanding of their capabilities.

Single Channel Ground and Airborne Radio (SINCGARS) is nearing completion of fielding in Korea. Ft. Hood (III Corps) is next. SINCGARS is the new VHF-FM combat net radio which hops rapidly through a selected frequency list (hopset) using VINSON for secure voice operation. It will be replacing the AN/VRC-12 family of combat net radios. The airborne version is the AN/ARC-201 which replaces the AN/ARC-54/131, AN/ARC-186, and AN/ARC-114. Future SINCGARS radios will have imbedded secure features eliminating the need for an external VINSON device. HAVE QUICK is a frequency hopping UHF radio used by the Air Force, Navy, and Army for air-to-air and air-to-ground communications. Present models use analog techniques. HAVE QUICK IIA (1992) will be all digital with very fast hop rates and

imbedded secure voice features.

Mobile Subscriber Equipment (MSE) is being fielded at Ft. Hood. It is the new divisional telephone system which replaces the VHF multichannel system. A characteristic of MSE is that it has a number of mobile subscriber radio terminals which allow users access to the system while mobile, just like a cellular phone system. Other features include call forwarding, SINCGARS radio wire integration, and facsimile access.

Enhanced Position Location and Reporting System (EPLRS) performs two functions: provides position of users on the battlefield, and is a message handling device. This system is a means to pass air picture data for the Forward Area Air Defense (FAAD) system.

Joint Version

Joint Tactical Information Distribution System (JTIDS) is the joint version of EPLRS. It also provides position location of users and passes large volumes of data, much faster than EPLRS. The Air Force and Navy use it for air picture transmission to and from fighter aircraft, ground/airborne surveillance systems, and ships. The Air Defense Artillery is pursuing acquisition of JTIDS radios to assimilate this larger air picture into their EPLRS network. Army Aviation has identified missions, such as deep attack, which require the volumes of data which JTIDS can deliver.

The Airborne Target Hand-over system (ATHS) is a communications modem that interfaces with any type of radio on the aircraft to provide a means to pass target data. It also receives target data from the above mentioned systems. It uses the same protocol (X.25) as EPLRS.

Upon fielding HAVE QUICK IIA in 1992,
(Combat — continued on page 50)

MAJ Bartosch is Chief of Avionics, Visionics, Electronic Warfare Branch, Dir. of Combat Developments, Fort Rucker, AL.



C³I: Integrated Avionics

by Mr. James M. Burwell

The Aviation Center Combat Developments article on Command Control Communications and Intelligence (C³I) discussed the communications systems now being fielded, describing how the new family of radios for Army aviation will be digitized, jam-resistant and secured.

Obviously, we have come a long way in improving our tactical communication systems. But these improvements described relate to the external transmission characteristics. What about the progress we are making inside the aircraft and inside the boxes? What are we doing to make them smarter, more flexible, and more reliable, especially in case of combat damage? In other words, how are we building and integrating the systems to make them better?

Old Black Box Philosophy

Ever since the first radio was installed in an aircraft, the Army has been doing things the same way. We build a green aircraft, get it flying pretty well, and then, almost as an afterthought, we start installing black boxes: UHF radio; FM radio; navigation system. In other words, a black box for each function we need. Pretty soon we've stuffed the aircraft so full of black boxes we can hardly reach inside to work on it. And the pilots have so many control heads crowding the cockpit they can hardly move, much less reach them all easily. We ran out of room in the COBRA a long time ago (I remember one export model with two control heads under the gunner's seat), and now we are running out of room in the center console of the BLACK HAWK.

The concept of one box for each function is very wasteful. You not only need a separate control head for each function, but separate,

Mr. Burwell is an Electronics Engineer in the Aviation Electronics Management Office, (AEMO), AVSCOM, St. Louis, MO.

dedicated wiring, and a separate mount for each remote system (that's where the black box isn't attached to the control head). The mount wastes space. The wiring accumulates until we have wrist-sized bundles. When something sent your way by some unpleasant and inhospitable people goes through the aircraft, it sometimes goes right through one of these bundles.

According to the sergeants in my General Support Avionics Company in Vietnam, such damage is far more difficult to repair and the repairs are far less reliable than you'd ever imagine. And finally, the aircraft is full of places for single point failures. That's where a single failure causes the loss of a system (say the transmitter portion of your UHF radio fails) and you can't get that system back until you fix the failure or damage.

So what do we do about it?

Integrated Avionics Philosophy

As a first step, instead of having a whole bunch of black boxes, each with a separate control, why not have one smart control for the pilot (and one for the copilot) that runs all of them on a data bus like the standard 1553 data bus?

This would get rid of a lot of those big, vulnerable wire bundles, replacing them with a bus (say a coax cable, or eventually an optical fiber) which could be dual or more redundant. This would also clear most of those control heads out of the cockpit. Such a step is one of the options currently being considered for the overcrowded BLACK HAWK console, and will be part of the APACHE Automatic Target Handover System (ATHS) installation beginning in late 1991.

We now have the beginnings of an avionics system in the aircraft. The black boxes can still be controlled if some of the redundant bus wiring is damaged, or if one of the controls fails. But

(Integrated — continued on page 52)

SUPERTEAM: THE SCOUT/

THEIR SCOUT/ATTACK HELICOPTERS.

LHX. THE ARMY'S NEW FIGHTER.

It's the first weapon system of its kind. A war-fighter designed from the ground up to take on the multirole mission the 21st century airland battlefield will demand. The first one ever built to knock ground and aerial opponents of any class right out of the ring.

The team to build it: SuperTeam.

Together we've built 100% of the U.S. Army's scout and attack helicopters. We've integrated man with advanced mission equipment in three of the country's current front-line fighters. And we've built supportability into our products that has earned them outstanding records for reliability, maintainability and operational readiness.

ATTACK WORLD CHAMP.

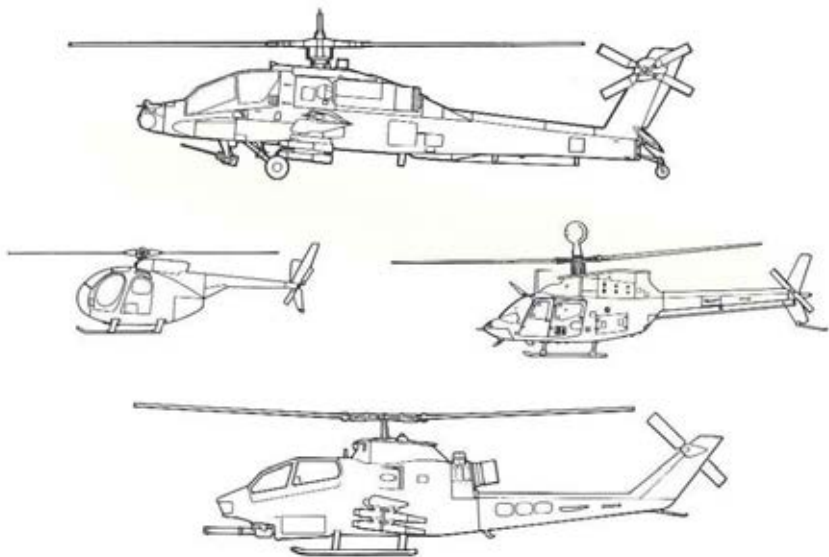

OUR SCOUT/ATTACK HELICOPTERS.

We will extend the limits of our ingenuity even further building the LHX. Because this new aircraft must be a scout with more stealth than the world has ever known. A lethal attack weapon. A fighter whose fancy footwork and powerful punch will outclass any challenger. It must also be affordable. And more support-

able than any aircraft now flying.

One team has the training to build a war-fighter like the LHX. One team has a 4-0 record, with every win a knockout. The SuperTeam.



LHX MCDONNELL DOUGLAS
SUPERTEAM
BELL HELICOPTER TEXTRON

WE PUT THE FIGHT INTO LHX.

Liaison:

Congressional Authorization Support

by Major General Charles E. Dominy



WASHINGTON, DC — The Armed Services Committees have completed work on the National Defense Authorization Act for FY89, and we have managed to come through a very tough year of intense scrutiny in good shape. Our amended budget request for FY89 asked for authorization to expend \$2,791.5 million for our Army Aviation programs.

Hearing the Army leadership's justification for this and much needed additional modernization support, the House Armed Services Committee (HASC) authorized \$2,959 million and the Senate Armed Services Committee (SASC) authorized \$2,794.9 million. Joint conference action between HASC and SASC has resulted in an agreed authorization of \$2,883.7 million for Army Aviation programs, a resultant increase of \$92.2 million above our request.

Fully Authorized

Most significant for next year is that Congress has authorized funds for procurement of the full request of 72 AH-64 APACHES, the full request of 72 UH-60 BLACK HAWKS, the full request of six EH-60 QUICKFIX, and the full request of six RC-12 GUARDRAIL/COMMON SENSOR aircraft (although no more than three can be procured until Congressional SIGINT reporting

MG Dominy is Chief of Legislative Liaison, HQDA, Washington, D.C.

requirements are met) and has increased our request of 24 AHIPs to 36, fully funded our aviation classified programs, and authorized a total of \$139 million for SOF aircraft.

Other Programs

Congressional support for other aviation programs is also

“Joint conference action . . . has resulted in an agreed authorization of \$2,883.7 million for Army Aviation programs, a resultant increase of \$92.2 million above our request.”

evident in that adequate funds were authorized to continue the OV-10 MOHAWK improvement program and to purchase ground support equipment and avionics, flight simulators, aircraft survivability equipment, and spares and repair parts.

Additionally, \$39.3 million was authorized to buy COBRAS with the important C-NITE capability along with authorization to fully fund our urgent AN/AVS-6 aviation night vision goggles request.

In large measure, the Appropriations Committees fol-

lowed suit and fully funded all of the above authorized programs, decrementing only our SOF aviation request to \$120.5 million for fiscal year 1989.

The Future

The requirements for aviation modernization competed very well this year in an environment with little flexibility in funding levels. Congress has recognized the value and validity of our programs and acted accordingly. I can also report that this is the first year in memory that we have had both authorization and appropriation acts passed before the end of the legislative year.

Looking into the crystal ball, it is clear that the new administration will have some tough choices to make in coming to grips with the budget deficit. I expect there will remain strong support for conventional forces; but, it is incumbent on all of us to demonstrate daily that we are first-rate stewards of the resources provided.

In closing, I extend special seasons greetings and best wishes for a happy and prosperous New Year — Above the Best.

IIII

Safety:

Record Set in Aviation Safety

by Colonel (P) Marvin E. Mitchiner, Jr.



FORT RUCKER, AL — Fiscal year 1988 was the safest year in the history of Army Aviation. The record-setting rate of 1.84 Class A accidents per 100,000 flying hours is the lowest rate recorded since Armywide aircraft accident data collection began in 1958. That year the Army's major — now called Class A — accident rate was 54.3 accidents per 100,000 flying hours.

FY88's Class A-C rate of 4.82 is also a record.

The Army achieved these records while flying increasingly more demanding missions and high-risk night tactical operations. Credit must go to leaders who managed the increased risks that go along with these more demanding missions, to aviation crews who performed to standard, and to aviation safety officers who supported their commanders with strong safety programs.

Safety Strategy

Today's Army Safety Strategy is built on the premise that training to standard is the key to preventing accidents. Emphasized from the top down, this strategy is producing results that show we're training safer than ever before in the face of tougher mission demands.

The major target of today's Army Aviation safety efforts is

COL(P) Mitchiner is Director of Army Safety and Commander, U.S. Army Safety Center, Ft. Rucker, AL.

human error, which is a factor in three out of four Class A accidents.

We address the problem through prevention products developed to make commanders, aviation safety officers, and aircrews aware of performance errors that cause accidents so they can integrate the lessons learned into their unit training programs. What we have done in night vision goggle safety awareness is one example.

“We have found videos to be a cost-effective way of getting the safety message to the field.”

NVG Safety

In one nine-month period last year, we had eight Class A aircraft accidents involving night vision goggles (NVGs). As a joint effort, the Safety Center and the Aviation Center sent an NVG team Armywide to focus attention on reducing human error in NVG operations.

In the nine months that followed, NVG Class A accidents were reduced by half. Then, during the first five months of this calendar year, we had five Class A night vision goggle accidents.

As a result, we again worked with the Aviation Center to produce two NVG videotapes. One

is targeted at operational pilots and focuses on NVG capabilities and limitations; the other is targeted at aviation unit commanders and focuses on developing an SOP for NVG operations.

These tapes were distributed Armywide, and commanders required all aviators to see the operational pilot film during unit training. In addition, the Aviation Center used the films in NVG training at Fort Rucker.

From the time the films hit the field in June through the end of the fiscal year in September, we had only one NVG-related Class A accident.

We have found videos to be a cost-effective way of getting the safety message to the field. Production and distribution costs of

the two NVG films totaled less than \$5,000, while the cost of Class A NVG accidents during FY88 averaged \$4 million each.

“Crashfax”

As a result of the success of our NVG videos, we are producing a series of “Crashfax Videos,” 3- to 4-minute recreations of Class A human-error aircraft accidents. These videos, which focus on the actions that set the stage for the accident, are available Armywide through installation Training Aids Service Centers for use by commanders and aviation safety officers in unit training programs. ■■■■

Combined Arms:

Update: Department of Combined Arms Tactics

by Colonel Malvin L. Handy



FORT RUCKER, AL — If you really want a challenging and varied job, get assigned to the Department of Combined Arms Tactics (DCAT) at Fort Rucker, AL.

Most of you know that DCAT provides tactical instruction to all officer and warrant officer professional development courses as well as to all aircraft qualification and instructor pilot courses taught at the Aviation Center. Many of you may not know that platform instruction is only a part of the mission of DCAT.

Whether you are interested in platform instruction, writing doctrine, briefing dignitaries from around the world on aviation employment, or hosting conferences, DCAT has a place for you. Listed below is an update of the major activities going on in DCAT.

Officer Training

We are putting the finishing touches on the new Reserve Component Aviation Officer Advanced Course (RC-AOAC). This restructured course consists of three phases. Phase I is a two-week resident Company Commander Module. The emphasis in Phase I is training on the administration of a company as well as the company-level tactical employment.

Phase II is a non-resident cor-

respondence module consisting of common core and aviation specific tasks. After the officer completes Phase II, we bring him back to the schoolhouse for Phase III. This phase is also a two-week resident module on aviation specific subjects. Successful completion of all three phases of instruction is required in order to graduate from the RC-AOAC.

“DCAT is . . . one of the few places that a captain can become branch qualified by being a tactics instructor.”

Warrant Officer Training

The first ever Master Warrant Officer Training Course (MWOTC) began on September 26, 1988. This course is designed to prepare master warrant officers to function as staff officers and monitors of command and worldwide programs within the scope of their military occupation specialties (MOS). Thirty warrant officers with a combined experience level of over 900 years Army service are attending this first class.

FM 1-100, Army Aviation in Combat Operations, the CAPSTONE manual for Army Aviation, was approved for production and worldwide distribution in August 1988. Expected distribution date of this manual is December '88.

FM 1-111, Aviation Brigades, is currently under revision. The first Coordinating Draft is scheduled for worldwide distribution in November 1988.

Conference Hosts

DCAT is hosting the 1988 Aviation Brigade Commanders' Conference (AVCOM) December 5-9, 1988. The theme of this year's conference is "Training: The Cornerstone of Combat Readiness".

We are expecting approximately 130 conference attendees.

As stated earlier, the Department of Combined Arms Tactics is an organization with varied missions. This update is only a small portion of the many challenges we face every day. DCAT is also one of the few places a captain can become branch qualified by being a tactics instructor. So, the next time you are looking for a challenging assignment, look to Fort Rucker and the Department of Combined Arms Tactics. ■■■■

Colonel Handy is Director, Department of Combined Arms Tactics, USAAWNC, Fort Rucker, AL.



**Complete
Communications
Control
...with the ICCS**

Canadian Marconi's Integrated Communications Control System (ICCS) provides audio distribution, voice warnings, data transmission, and control of government-furnished crypto equipment and radios in a single package. The ICCS provides high-quality audio distribution of up to 24 channels. Crew-to-crew, crew-to-radio, and aircraft-to-crew communications are handled with complete flexibility via either a MIL-STD 1553B interface or discrete input lines.

Contact us to find out how you can get complete comms control.



eme

Canadian Marconi Company
Avionics Division

Avionics Products Group, P.O. Box 13330, Kanata, Ontario, Canada K2K 2B2, Tel. (613) 592-6500

Aviation Medicine:

U.S. Army School of Aviation Medicine

by LTC David J. Wehrly, MC, SFS



FT RUCKER, AL — The United States Army School of Aviation Medicine (USASAM), located at Fort Rucker, Alabama, was established on October 1, 1984 when it became a branch school of the Academy of Health Sciences, Fort Sam Houston, Texas.

Previously, the Department of Education and Training, U.S. Army Aeromedical Activity conducted the aeromedical training mission.

The Mission

USASAM's mission is to provide standardized worldwide aeromedical education and training to the U.S. Army, and upon request to other U.S. military services and friendly foreign nations. Our training programs fall into two major categories; those for medical personnel and those for aviation personnel.

Training for medical personnel is provided by the Aeromedical Education Division via four Programs of Instruction (POIs); the US Army Flight Surgeon Primary Course (61N9D), the Aviation Medicine Orientation Course (AMOC), Flight Medical Aidman Course (300-F6), and Essential Medical Training for Army Medical Department (AMEDD) Aviators Course (2C-F7).

The Flight Surgeon's Course, seven weeks in length, is taught three times per year training 126 students annually. The course

LTC Wehrly is Dean, U.S. Army School of Aviation Medicine, Fort Rucker, AL.

prepares flight surgeons to deal with special needs of the aviation community and to function effectively in the staff officer role.

The AMOC, two weeks in length, prepares physicians for the Army aviation medicine program who have received their aviation medicine training from another military service. Most AMOC students come to us from the reserve components.

The Flight Medical Aidman Course is a four week POI designed to teach medics to function in the aeromedical evacuation environment. The course is taught four times per year with 25 students per class.

The Essential Medical Training for AMEDD Aviators Course, a two week POI, is taught four times per year with 25 students per class. This course provides pilots assigned to aeromedical evacuation units with a general knowledge of medical problems, emergency care techniques, and procedures for the combat zone evacuation mission.

Aeromedical Factors Division

USASAM's Aeromedical Factors Division provides aeromedical training annexes to over thirty US Army Aviation Center (TRADOC) POIs. Academic subjects taught to initial entry, refresher, transition, instructor pilot and precommand aviators include introduction to the aviation medicine program, altitude physiology, stress and fatigue,

G-forces, aviation toxicology, effects of temperature extremes, noise hazards, principles and problems of vision in aviation, oxygen equipment systems use, and spatial disorientation. Practical applications are demonstrated to the students in the Barany chair (spatial disorientation), altitude physiology and hypoxia (altitude chamber), and night vision limitations (night vision classroom/laboratory).

Staff Assistance

USASAM's cadre of nine MSC aviator, physiological training officers is assisted by four flight surgeons and fifteen NCO instructors. USASAM provides approximately 12,000 classroom instruction hours to over 8,000 students in addition to 340 altitude chamber "flights" per year.

About 200 hours flight time per year are devoted to UH-1V rescue hoist training in addition to aeromedical evacuation field training exercises. Flight surgeon and flight medical aidman students receive initial training in the Navy's 9D5 multiplace underwater egress trainer.

New to our mission is participation in the FORSCOM/TRADOC Aviation Resource Management Surveys (ARMS). MSC aviators from USASAM instructor cadre perform the aviation medicine portion of the ARMS reviews. This provides USASAM with a direct assessment capability to review the appropriateness of our training and performance of our graduates.

We at USASAM eagerly anticipate future challenges and opportunities to improve our support to medicine and aviation. Near term plans call for an additional POI to provide (USASAM — cont. on p. 53)

Training:

What is NET?

by Sergeant Major Joseph W. Jordan



ST. LOUIS, MO — What is it? A net for basketball, tennis, or hockey? No, it is New Equipment Training (NET). It is a vital part of developing and fielding a new system to units in the Army. I will discuss some of the elements, responsibilities and problems in deploying a New Equipment Training Team (NETT) as the equipment is received by a unit.

Once a Required Operational Capability (ROC) has been written for a new system, NET personnel start their initial reviews of like systems to determine who will operate and maintain the equipment.

During the Demonstration and Validation (DVAL), NET prepares the Qualitative and Quantitative Personnel Requirements Information (QQPRI) documents on personnel qualities and quantities for staffing throughout the Army. Also during DVAL, NET looks at test equipment, tools, support equipment and training that may be required.

Prime Monitor

After the system makes it through DVAL to Full Scale Development (FSD), NET becomes very busy writing and coordinating Statements of Work for training. The contractor begins his full Logistics Analysis of system and starts developing

SGM Jordan is NCOIC, responsible for NET for CH-47D and Aviation Ground Power Unit, U.S. Army Aviation Systems Command, St. Louis, MO.

his training plan. NET becomes the prime monitor along with the respective service schools, ensuring that what the contractor is developing meets the needs of the school and can be used for a NETT to train First Units Equipped (FUE) with the new system.

NETP

To get all this in motion, funds are programmed for the development and training of Army instructors, as well as funds to deploy the NETT. New Equipment Training Plans (NETP) are developed and are the basis for the funds and are updated with many items of information to track such things as personnel requirements, basis of issue plans, technical manuals, factory training, first unit equipped, and the planned deployment of NETT.

NET reviews the Logistics Analysis Records as they are completed by the contractor. As the contractor develops the training plan and lesson materials, NET continually monitors and provides feedback to the contractor from reviews by NET and the service schools.

While the courses are prepared and the equipment is readied for training, NET is coordinating who will attend the contractor presented training courses. Generally the service school has most of the class seats, but personnel from safety, test personnel, and the

first unit to be equipped also attend. NET has programmed funds for this training and pays for some of the personnel attending the course, generally those personnel that will make up the NETT. NET is the course monitor for courses presented and has the responsibility for what corrections must be made to courses as they are being presented.

NETT is used when the service school has or cannot produce trained personnel for first unit to receive the new equipment. Sometimes when only an improvement is made to an existing system a NETT will deploy as the improvement is being implemented, to train new operator or maintenance procedures. We have discussed NET development, I will now explain deployment of the NETT to receiving units.

Deployment

NET is responsible for all coordination with the receiving unit. The first meeting is generally set up by a telephone call for a New Material Introductory Briefing (NMIB).

The NMIB always occurs on major systems but may be used on smaller systems too. The difference on a large system is there may be several briefers, where on a small system only the NET manager will brief the training.

NET is responsible for funding and coordinating with project managers and receiving unit for these briefings. After the initial NMIB there will be many telephone calls and other visits prior to the NETT arriving on site to train the unit.

Areas of concern and coordination with units receiving NET (NET — cont. on page 52)

Reserve Components:

ARNG Safety Update

by Colonel John J. Stanko, Jr., Ret.



ABERDEEN PG, MD — When we reviewed our Safety Report Card for last year there was a sense of accomplishment and satisfaction at the National Guard Bureau. The Class A, Aircraft accident rate was at 1.0 per 100,000 flying hours. That is the best rate the Army National Guard has ever achieved.

Zero Objective

Our objective, of course, is zero. People were skeptical when we established that objective 22 years ago and with reason — the ARNG aircraft accident rate in

challenge to aviation commanders and managers whenever that happens is to do three things. (1) Maintain your faith in your program (2) Insure that "by the book" operations are being conducted, and (3) Control hazards that cannot be eliminated.

Our report cards indicate that we have been able to do this.

We do it through an analysis and countermeasure concept of safety enhancement. Our program is being copied by other Department of Defense and Non Department of Defense agencies.

"Insure that 'by the book' operations are being conducted, and . . . control hazards that cannot be eliminated."

the early 1960s was still in the high 30s. With persistence, enthusiasm, dedication and patience the glide slope has inexorably been tracing down.

It has not always been easy. Through the years the curve would inexplicably reverse itself and turn upward. The immediate

The next issue of Army Aviation will contain an article by Major Richard Sherman, a member of the Aviation Safety Team from the Safety Branch, Aviation Division, National Guard Bureau. It is appropriate and timely as we begin the new fiscal year. FY88, the year of training, was highly successful for the ARNG and especially rewarding because of the excellent safety effort. IIIII

COL Stanko is Chief, Army Aviation Division, National Guard Bureau, Aberdeen Proving Ground, MD.

Statement of Ownership, Management, And Circulation (Required by 39, U.S.C. 3685)

Title of publication: Army Aviation (ISSN 0004-248X). Date of filing: September 3, 1988. Frequency of issue: monthly, except April and September (10). Annual subscription price: \$25.00. Location of known office of publication: 49 Richmondville Avenue, Westport, CT 06880-2000. Location of headquarters or general business office of the publisher: Same. Publisher: Lynn Coakley, 49 Richmondville Avenue, Westport, CT 06880. Editor: William R. Harris, Jr. Managing Editor: None. Owner: Army Aviation Publications, Inc., 49 Richmondville Avenue, Westport, CT 06880-2000; Lynn Coakley, 28 Fairfield Avenue, Westport CT 06880. Known bondholders, mortgagees, and other security holders owning or holding 1% or more of the total amount of bonds, mortgages or other securities: none.

The average no. of copies each issue during the preceeding 12 months, and the actual number of copies of the issue published nearest to the filing date (later appears in parenthesis) were:

a. Total No. Copies (Net Press Run): 16,910 (16,900); b. Paid Circulation: (1) Sales through dealers, carriers, counter sales: NA (NA); (2) Mail subscriptions: 15,536 (15,279); c. Total Paid and/or Requested Circulation: 15,536 (15,279); d. Free distribution by mail, carrier or other means: Samples, complimentary, and other free copies: 401 (344); e. Total distribution (Sum of c and d): 15,967 (15,623); f. Copies not distributed: (1) Office use, left over, unaccounted, spoiled after printing: 973 (1277); (2) Returns from news agents: NA (NA); g. Total (Sum of e, f1 and f2 — should equal net press run in a: 16,910 (16,900).

I certify that the statements made by me in this statement and dated September 3, 1988 are correct and complete.

Lynn Coakley
Publisher

TEXAS THUNDER



Hookmaster □ Chinook Ds · Taming the Texas Skies.

The Texas National Guard Hookmaster and advanced Chinook 47Ds team up to tame the skies over the Lone Star state.

The new 47Ds, the first ever received by a Guard unit, greatly strengthen the Guard's capabilities and technology for a

swift, sure, day-or-night response to crisis wherever and whenever it occurs.

This is the twelfth consecutive on-time delivery of modernized CH-47Ds to the U.S. Army.

BOEING

Hardware:

Armed OH-58D: Status Report

by Colonel James R. Cox



FT RUCKER, AL — It is hard to believe that it has been a year since I last reported on the status of the OH-58D program. It is even harder to believe the milestones and events the program has experienced during that period. The purpose of this report is to update the status of the fleet in the field, announce the emergence of the Armed OH-58D, and discuss briefly changes in authorized missions and near term fieldings.

In previous reports, I indicated that the OH-58D had successfully completed a retest of the aircraft in the air recon role. As it turns out, the Army Aerial Scout Test (AAST I) was a key element in the reinstatement of the OH-58D program. DA staff and OSD spent months reviewing and analyzing the Test Report and Independent Evaluation Report. There is no question that the OH-58D emerged as the dominant scout aircraft.

The Honorable William H. Taft, IV, Deputy Secretary of Defense, certified to the Congress, on 30 August 1988, that based on the AAST, "...the AHIP is the most cost-effective aerial scout aircraft available to the Army at this time." That certification, coupled with a renewed confidence in the OH-58D, has broken the log jam and clears the path for future production. I'll return to this sub-

COL Cox is TRADOC System Manager for Scout Helicopters, USAAVNC, Fort Rucker, AL.

ject in just a moment, but there are other circumstances that boosted AHIP's future.

Armed Recon

In August of 1987, the Army accepted a mission from the

18th Aviation Brigade, Fort Bragg, could fill another full article but will not be addressed here, other than to say they have done a super job.

The aircraft armed for TF 118 served to prove the principle of armed recon with the OH-58D and has been instrumental in supporting the overall concept of an armed scout.

Armament Package

The armament package allows maximum flexibility to provide close-in self-protection and

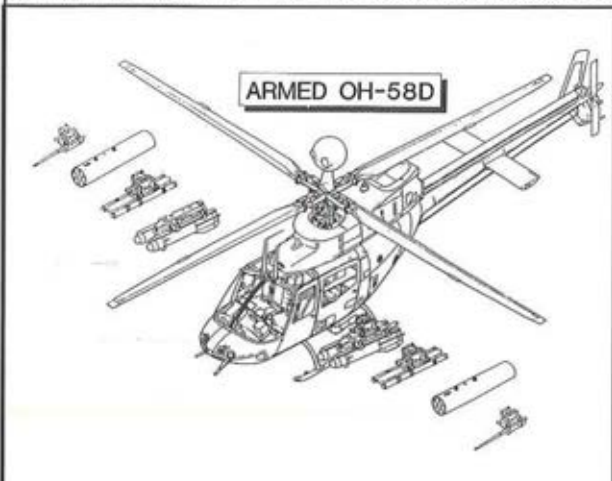

JCS to provide armed reconnaissance helicopters to operate with the U.S. Navy in the Persian Gulf. Because of its small size and modern mission equipment package, the OH-58D was selected. Bell Helicopter, AVSCOM, FORSCOM, and TRADOC completed a Herculean effort to develop and test the armament packages, organize and train the unit, and deploy the first increment in about six months. The accomplishments and success of Task Force 118,

area suppressive fires against personnel, soft material, and air-to-air targets as well as point target/anti-armor capability. Bell Helicopter had previously completed substantial development of similar armament for the Bell 406 Combat Scout Program, which has an airframe, power plant, and rotor system common with the OH-58D.

The Armed OH-58D is configured with a universal mounting system that allows rapid (five OH-58D — cont. on page 49)

The 1988 SPOOF Roster

Published by Army Aviation Publications, 49 Richmondville Ave., Westport, CT 06880

1988 Roster Code

Last Name, First Name, MI
(Retired Rank)
(First AAAA Membership Year)
(Nickname)
Residence Address
Business (Duty) Phone
Residence Phone

Spouses Name
Job Title
Company Name
Previous Military Service
Year of Retirement
Years of Active Military Service
AAAA Offices Held

ACHEE, Sidney W., (COL) (M57) (E) Sid 724 Oakwood Trail, Ft Worth, TX 76112. Res: (817) 457-5321. S: Ruth. Svc: USA. Ret: 73. 30 yrs. Past Pres, Army Avn Center Chapter.

ADAMS, Rodney A., (MAJ) (M72) (Rod) 2613 Walnut Lane, Plano, TX 75075. Dy: (214) 457-7712. Res: (214) 964-0248. S: Kay. Job: Program Mgr, E-Systems. Svc: USA. Ret: 86. 20 yrs. Sec, North Texas Chapter.

ADAMSON, George W., (COL) (M59) (Wally) 1806 Brooktrail Ct, 008, Vienna, VA 22180. Dy: (703) 938-6070. Res: (703) 281-5538. S: Jane. Job: Asst Vp/Sales Mgr, Shannon & Luchs, Realtors, Vienna/Dakota Office. Svc: USA. Ret: 76. 23 yrs. Past NEB, Past Vp, Washington DC Chapter.

ADDY, B. Walter, (LTC) (M62) (Walt) 6600 Sugar Creek Dr N., Mobile, AL 36695. Dy: (205) 479-0511. Res: (205) 633-8750. S: Margaret. Job: Instructor JROTC, Mobile. Svc: USA. Ret: 81. 24 yrs.

ADEIMY, Thomas E., (CW3) (M77) (Tom) 900 Hylan Avenue, Hamlet, NC 28345. Res: (919) 582-3226. S: Eleanor. Svc: USA. Ret: 81. 36 yrs. Past SRVP.

ADESSA, Anthony J., (COL) (M61) (Tony) 26 Evergreen Drive, North Caldwell, NJ 07006. Dy: (201) 228-0988. Res: (201) 228-3488. S: Susie. Job: Industrial Mktg. Svc: USA. Ret: 79. 26 yrs.

ADIE, John R., (COL) (M60) (John) 118 Mard Marion Place, Williamsburg, VA 23185. Res: (804) 229-0515. S: Julia. Svc: USA. Ret: 73. 30 yrs. Past Pres, Stuttgart Chapter.

ADUÉ, Eugene L., (LTC) (M58) (Gene) 902 Verna Lane, Harker Heights TX 76543. Res: (817) 698-3812. S: Robbie. Ret: 76. 36 yrs.

AGUANNO, Edwin M., (MG) (M58) (Ed) 3714 Ivanhoe Lane, Alexandria, VA 22310. Dy: (703) 848-5172. Res: (703) 960-7060. S: Winifred. Job: Vp, Tactical Warfare Systems, BDM Corp. Svc: USA. Ret: 88. 33 yrs. Past Pres, Washington DC Chapter.

AKIN, Robert F., (MAJ) (M58) (Bob) 601 Cedar Drive, Enterprise, AL 36330. Dy: (205) 255-5600. Res: (205) 347-5336. S: Angie. Job:

Educ Spec, USAAVNC. Svc: USA. Ret: 73. 25 yrs. AAAA Life Member.

AKRIDGE, Jimmie H., (COL) (M86) (Jim) 482 St Johns Drive, Satellite Beach, FL 32937. Dy: (407) 729-2740. Res: (407) 777-5705. S: Carol. Job: Program Mgr, Harris Corp. Svc: USA. Ret: 85. 31 yrs.

ALDRIDGE, George W., (COL) (M57) Highland West No. 1613, 4450 South Park Ave., Chevy Chase, MD 20815. Dy: (301) 657-7770. Res: (301) 951-6090. S: Joan. Job: Assoc, Mass Mutual-Wash Agency. Svc: USA. Ret: 73. 30 yrs. Past VP, Rhine Valley Chapter.

ALLARI, Ronald L., (MAJ) (M76) 3508 Misty Creek, Erlanger, KY 41018-2627. Dy: (606) 525-3409. Res: (606) 331-4371. S: Ann. Job: Asst Chief Pilot SA227, COMAIR Airlines. Svc: USA. Ret: 86. 21 yrs.

ALLEN, Kenneth W., (MAJ) (M64) 434 Jeffrey Lane, Copperas Cove, TX 76522. Res: (817) 547-7395. S: Wilma. Job: Staff Member, Computer Programmer, BDM Corp. Svc: USA. Ret: 84. 21 yrs.

ALLGOOD, Charles N., (COL) (M57) (Chuck) 5 N. Royal Links Circle, Antioch, CA 94509. Dy: (415) 894-3051. Res: (415) 778-2766. S: Anne Marie. Job: Opns Rep, Chevron USA, San Francisco. Svc: USA. Ret: 75. 28 yrs.

ALT, Albert C. Jr., (LTC) (M72) (Bert) 521 Ranch Drive, Manchester, MO 63011. Res: (314) 227-5229. S: Gerry. Svc: USA, USAF. Ret: 66. 24 yrs.

ALVERSON, Frank L. Jr., (LTC) (M73) 2739 Floresta Dr. NE, Palm Bay, FL 32905. Res: (407) 727-7123. S: Mary. Svc: USA. Ret: 85. 22 yrs.

AMICK, Carl L. Jr., (CW4) (M70) 1811 McHardy Street, P.O. Box 237, Newberry, SC 29108. Res: (803) 276-4051. Svc: USA. Ret: 87. 23 yrs.

ANCELIN, Donald R., (LTC) (M83) (Don) 528 Gold Street, Toms River, NJ 08753. Dy: (201) 323-2114. Res: (201) 286-4629. S: Carole. Job: Flt Opns Ofcr GM-13 Airborne Electronics Research Activity. Svc: USA. Ret: 86. 20 yrs.

ANDERSON, James R., (CW4) (M72) (Jim) P.O.

Box 2473, Corrales, NM 87048. Dy: (817) 265-4239. Res: (505) 898-2384. S: Michele. Job: Pilot, American Airlines, DC-10. Svc: USA. Ret: 84. 20 yrs. Past Treas, Stuttgart Chapter.

ANDERSON, John H., (LTC) (M57) 102 White Oak Circle, Ozark, AL 36360. Dy: (205) 598-8514. Res: (205) 774-6936. S: Mary. Job: Sr Army Instr, Daleville HI Sch. Svc: USA. Ret: 71. 20 yrs.

ANDERSON, Marris D., (LTC) (M87) 216 Lakewood Drive, Enterprise, AL 36330. Dy: (205) 347-4238. Res: (205) 393-4376. S: Wanda. Job: District Mgr, USPAIRA. Svc: USA. Ret: 81. 22 yrs.

ANDRUS, Rulon, (CPT) (M57) (Andy) 2450 Roycroft Avenue, Long Beach, CA 90815. Res: (213) 597-2655. Ret: 72. 25 yrs.

ANGLIN, Richard C., (COL) (M63) 600 Tallahassee Drive, NE, St. Petersburg, FL 33702. Dy: (813) 577-9024. S: Margaret. Job: Consultant, Self Employed. Svc: USA. Ret: 85. 28 yrs. Past Sec, Hanau Chapter.

ANTHONY, James G., (COL) (M85) (Tony) 429 Sunnybrook Court, Bedford, TX 76021. Dy: (817) 282-2557. Res: (817) 282-2062. S: Shirley. Job: Flight Safety Intl, Dir of Trng. Svc: USA. Ret: 80. 32 yrs.

ANTROSS, Richard C., (COL) (M59) (Dick) 2208 Cherokee Trail, Valrico, FL 33594. Dy: (813) 885-4302. S: Kathryn. Job: U of So FL. Svc: USA. Ret: 87. 30 yrs. Past VP, Suncoast Chapter.

ANZALOTTA, Orlando, (CW4) (M64) Espana C-13 Oasis Gardens, Guaynabo PR 00657. Dy: (809) 791-2408. Res: (809) 789-2416. S: Genevieve. Job: Supt, Texaco Intl Airport, San Juan, PR. Svc: USA. Ret: 71. 23 yrs.

APEL, Albert L., (MAJ) (M72) 104 Beverly Drive, Enterprise, AL 36330. Dy: (205) 255-3275. Res: (205) 347-1028. S: Mary. Job: Tng Spec, USAAVNC. Svc: USA. Ret: 77. 22 yrs.

ARANYOSI, Alexander J., (MAJ) (M59) (Al) 638 Harvester Drive, Foster City, CA 94404. Res: (415) 574-1687. S: Mary Ann. Svc: USA. Ret: 66. 20 yrs.

ARCHAMBAULT, Robert M., (MAJ) (M76) (Arch) 640 Cumberland, Hoffman Estates, IL 60194. Svc: (312) 882-8367. Svc: USA, USAF. Ret: 82. 40 yrs.

AREND, Leland R., (SGM) (M79) 26621 SW 124th Avenue, Homestead, FL 33032. Res: (305) 258-2896. S: Diana. Job: A&P Mech. Eastern Airlines, Miami. Svc: USA. Ret: 80. 24 yrs.

ARMSTRONG, Donald, (LTC) (M57) (Don) 27915 Ridgebrook Court, Rancho Palos Verdes, CA 90274. Dy: (213) 988-5360. Res: (213) 377-8963. S: Elna. Job: Mgr. Ft Test Br Office. Svc: USA. Ret: 78. 31 yrs.

ARNET, Robert A., (COL) (M58) (Bob) 5318 Valburn Circle, Austin, TX 78731. Dy: (512) 346-9162. Res: (512) 345-0071. S: Nadine. Job: Real Est Broker/Owner, Nadine Arnet Realtors. Svc: USA. Ret: 78. 27 yrs.

ARNOLD, Reginald, (MSG) (M85) (Pete) 10815 Keese, Houston, TX 77089. Dy: (713) 528-9912. Res: (713) 947-2343. S: Victoria. Job: Gen. Mgr. Grif's Inn. Svc: USA. Ret: 82. 20 yrs.

ASBURY, Harold D., (LTC) (M57) (Harry) Route 1, Box FA 43, Eufaula, OK 74432. Res: (918) 452-3410. S: Eloise. Job: Tax Counselor, Volunteer, Tax Counseling for the Elderly. Svc: USA. Ret: 68. 26 yrs.

ASCHOFF, John F., Jr., (LTC) (M58) (Jack) 310 Faircross Circle, San City Center, FL 33570. Res: (613) 634-1915. S: Anne. Svc: USA. Ret: 67. 27 yrs. Past Treas. Washington DC Chapter.

ASHTON, Ardis T., (CW4) (M84) (Art) 15201 Se 5th Street, Vancouver, WA 98664. Dy: (503) 281-3300. Res: (206) 256-9580. Job: Chief Pilot, Flight Craft Inc, Portland, OR. Svc: USA. Ret: 84. 20 yrs.

ATKINSON, Donald E., (LTC) (M58) (Don) Route 1, Box 449, Fortson, GA 31808. Res: (404) 324-6076. S: Edith. Svc: USA. Ret: 66. 24 yrs.

ATWOOD, Walter W., (MAJ) (M73) 5521 E. Gelding Drive, Scottsdale, AZ 85254-2948. Dy: (602) 731-5283. S: Lisa. Ret: 82. 21 yrs.

AUFILL, John S., (COL) (M62) 5501 Allin Road, Prince George, VA 23875. Res: (804) 733-3383. S: Rosemary. Svc: USA. Ret: 71. 24 yrs.

AUVIL, Huey C., (SGM) (M84) Route 1, Box 43-20, Leavenworth, KS 66048. Dy: (913) 682-2000. Res: (913) 682-2767. S: Gladys. Job: Medical Supply UAC. Svc: USA. Ret: 85. 30 yrs.

AVRETT, Marion E., (LTC) (M75) (Ted) P.O. Box 1158, Enterprise AL 36330. Dy: (205) 347-3461. Res: (205) 347-9567. S: Jimmie. Job: Pres. Ted Avrett Motors, Inc. Svc: USA. Ret: 64. 23 yrs.

BBBBBBBBBBBB

BAEB, David E., (COL) (M59) E 2307 Woodridge Drive, Waupaca, WI 54981. Dy: (715) 258-5577. Res: (715) 258-7808. S: Pat. Job: VP Ops, Moore-o-Matic, Inc. Svc: USA. Ret: 86. Past Pres.

BAILEY, Alonza T., (CW4) (M62) 3354 Mayflower Street, Sarasota, FL 34231. Dy: (813) 922-9217. Res: (813) 922-9217. S: Pat. Job: Pres. Carol Brook, Inc. Svc: USA. Ret: 74. 26 yrs. Past VP, Follow Me Chapter.

B The SPOOF Roster

BAILEY, Lawrence R., (COL) (M57) (Bob) 3035 Paces Lake Court NW, Atlanta, GA 30339. Res: (404) 436-3350. S: Mary-Jean. Svc: USA. Ret: 70. 28 yrs. Past VP, Greater-Atlanta Chapter.

BALBERDE, Alexander, (LTC) (M63) (Al) 5415 Gove Yearley Drive, Fairfax, VA 22032. Dy: (703) 549-6555. Res: (703) 278-8465. S: Diane. Job: VP, Contraves Corp. Svc: USA. Ret: 79. 20 yrs.

BALDASARE, Michael L., (LTC) (M57) (Mike) 21215 Chocktaw Drive, Diamond Bar, CA 91765. Dy: (714) 597-1881. Res: (714) 595-4165. S: Eunice. Job: Corp Hcpr Pilot, So. California Edison Co. Svc: USA. Ret: 71. 20 yrs. Charter Member-AAAA.

BANEY, Robert A., (CW4) (M62) 1462 Cardinal Lane, S.W., Austell, GA 30001. Res: (404) 941-0473. S: Carol. Svc: USA, USN. Ret: 75. 30 yrs.

BANKS, Douglas T., (LTC) (M58) 325 Miami Avenue, Indianalatic, FL 32903. Dy: (305) 723-0934. Res: (305) 724-2918. S: Lynn. Job: Pres, Banks Realty. Ret: 77. 24 yrs.

BANKS, Richard T., (LTC) (M87) Tracor Inc., Westmark, 6500 Tracor Lane, Austin, TX 78725-2070. Dy: (512) 929-2803. Res: (512) 540-4969. S: Janice. Job: Pgm Mgr, Tracor Aerospace. Svc: USA. Ret: 67. 21 yrs.

BANKS, Sam A., (LTC) (M58) (Sammy) 6980 Camino Degrazia, San Diego, CA 92111. Dy: (619) 560-9312. Res: (619) 546-2460. S: Carole. Job: Resident VP, Insurance Co of the West/Explorer Ins Co. Svc: USA. Ret: 73. 20 yrs.

BARKLEY, James R., (LTC) (M58) (Jim) 1909 Cleburn Drive, Arlington TX 76012. Dy: (817) 280-3047. Res: (817) 461-2039. S: Margaret. Job: Mgr Cust Training Academy, Bell Hcpr Textron. Svc: USA. Ret: 73. 29 yrs. Past VP, Rhine Valley Chapter.

BARKSDALE, Lewis B., (LTC) (M63) (Lew) 218 Aspen Boulevard, Yorktown, VA 23692. Dy: (804) 874-7114. Res: (804) 898-8496. S: Joann. Job: Principal Analyst, Cobre Corp. Svc: USA. Ret: 82. 24 yrs. Past Treas, Arizona Chapter.

BARRECA, Nicholas E., (COL) (M69) (Nick) Wiregrass Total Eye Care, 207 E Brunson St, Ste 300, Enterprise, AL 36330. Dy: (205) 347-7822. Res: (205) 983-4117. S: Eileen. Job: Avn Ophthalmologist, Owner Wiregrass Total Eye Care Clinic. Svc: USA. Ret: 83. 20 yrs.

BARRIOS, Willie W.J., (LTC) (M57) (Bill) 6551 Iron Liege Trail, Tallahassee, FL 32308. Dy: (904) 668-0757. S: Frances. Svc: USA. Ret: 65. 25 yrs.

BARRY, John W., (MAJ) (M59) P.O. Box 130, Marysville, MI 48040. Res: (313) 364-4802. Ret: 72. 20 yrs.

BASOM, Darrel W., (LTC) (M58) 1718 Wetherly Court, Las Vegas, NV 89115. Res: (702) 453-6398. S: Sandi. Job: Home Business. Ret: 81. 28 yrs.

BASS, Paul W., (MAJ) (M58) (Sam) 341 Todd Lane, Belleville IL 62221. Dy: (314) 263-1961. S: Carolyn. Job: Test Progs Coordinator, Apache PMO. Svc: USA, USN. Ret: 67. 23 yrs.

BASS, Ralph L., (CSM) (M71) 1305 Kingston Way, Apt. 101, Chesapeake, VA 23320-4621. Dy: (804) 855-0155. Res: (804) 547-8325. S: Arnetus. Job: Gen. Mgr, VA Materials Corp. Svc: USA. Ret: 76. 30 yrs. Past VP, Coastal Empire Chapter.

BAUER, Richard E., (CW4) (M85) (Dick) HC 31 400 JA-E, Alliance, NE 69301. Res: (308) 762-4000. Job: Self Employed. Svc: USA. Ret: 86. 20 yrs.

BAUGH, Russell E., (COL) (M58) (Russ) 1041 Overton Lea Road, Nashville, TN 37220. Res: (615) 373-1190. S: Elisabetha. Job: Retired - Service Mde Co. Svc: USA, USAF. Ret: 78. 31 yrs. Past VP, Morning Calm Chapter.

BAUGH, Willard A., (MAJ) (M57) (Willie) 105 Andrews Avenue, Enterprise, AL 36330. Res: (205) 347-9032. S: Barbara. Ret: 65. 20 yrs.

BEARDEN, William A., (COL) (M57) (Bill) 6225 Trail Lake Drive, Fort Worth, TX 76133. Res: (817) 292-1759. S: Stefanie. Svc: USA. Ret: 74. 32 yrs.

BEATTY, George S.Jr., (MG) (M59) (George) 297 Pickwick Road, Savannah, GA 31410. Res: (912) 897-4935. S: Jake. Job: Consultant. Svc: USA. Ret: 75. 35 yrs. NEB.

BECKEL, Charles E., (LTC) (M59) (Chuck) 8416 Ne 72nd Circle, Vancouver, WA 98662. Dy: (206) 896-7270. Res: (206) 892-7626. S: Jo. Job: Assistant Principal, Hudson's Bay Hs, Vancouver Schl District. Svc: USA. Ret: 76. 20 yrs.

BECKER, William A., (MG) (M63) (Bill) Oakhill route 1, Box 1095, Kaufman, TX 75142. Dy: (214) 932-6100. Res: (214) 498-5521. S: Fran. Job: Pres, W.A. Becker Realty, Inc. Svc: USA. Ret: 71. 30 yrs. Past NEB.

BEDSOLE, William K., (LTC) (M59) (Ken) 305 Oakwood Drive, Enterprise, AL 36330. Dy: (205) 347-6824. Res: (205) 347-7949. S: Dorothy. Job: Lead Instructional Developer, Seville Training Systems. Svc: USA. Ret: 85. 28 yrs.

BELCHER, L. Fred, (COL) (M59) 3406 John Glenn, San Antonio, TX 78217. Res: (512) 657-1623. S: Jenny. Svc: USA, USAF. Ret: 87. 37 yrs.

BELL, Lawrence A., (COL) (M59) 150 Heron Drive, Melbourne Beach, FL 32951. Res: (407) 729-4398. S: Mary Ann. Ret: 86. 30 yrs. Past Pres, Follow Me Chapter.

BENNETT, Willard M., (COL) (M59) (Will) 739 Tallahassee Dr., N.E., St. Petersburg, FL 33702. Dy: (813) 327-6776. Res: (813) 576-4198. S: Vonnie. Job: Broker/VP, Fortune Corp, Tampa. Svc: USA. Ret: 80. 27 yrs. Past VP, Suncoast Chapter.

BERDUX, Sylvester C., (COL) (M58) (Syl) 4201 Pickering Place, Alexandria, VA 22309. Dy: (703) 558-9621. Res: (703) 360-3368. S: Sandy. Job: Senior District Rep, Boeing Hcpr. Svc: USA. Ret: 81. 28 yrs. NEB. Past Sec, Washington DC Chapter.

BERGERON, Andrew L., (LTC) (M62) (Andy) 1877 Las Gallinas Avenue, San Rafael, CA 94903. Dy: (415) 834-2390. Res: (415) 472-1891. S: Carol. Job: Financial Consultant, Thomson McKinnon Securities, Inc. Svc: USA. Ret: 83. 22 yrs.

BERGERON, Leo E., (COL) (M57) (Bergie) 7400 Crestway, Apt. 201, San Antonio, TX 78239. Res: (512) 590-1446. S: Mary. Svc: USA. Ret: 70. 28 yrs. Past Treas, Greater-Atlanta Chapter.

BERNER, John J., (COL) (M71) (Jack) 1072 Carriage Hill Pkwy., Annapolis, MD 21401. Dy: (301) 459-4343. Res: (301) 798-5735. S: Claire. Job: Mgr. Army Systems, American Electronics, Inc. Svc: USA. Ret: 86. 30 yrs.

BERRY, Sidney B., (LTG) (M71) (Sid) 2407 North Kenmore Street, Arlington, VA 22207. Res: (703) 524-4766. S: Anne. Job: Consultant. Svc: USA. Ret: 80. 32 yrs.

BERRY, Thomas P., (LTG) (M77) (Tom) 738 Benfield Road, Severna Park, MD 21146. Dy: (202) 646-2138. Res: (301) 987-5331. S: Donna. Job: Mgr. System Implementation Pgm, Arinc Resear Corp, Annapolis. Svc: USA. Ret: 74. 20 yrs.

BERTHOY, Hugh V., (CW4) (M62) (Bert) Route 4, Box 274, Seguin, TX 78155. Dy: (512) 379-5740. Res: (512) 379-0120. S: Willa. Job: Safety Supvr, Durham Trans Co. Svc: USA. Ret: 78. 30 yrs.

BESSON, Frank S. III, (LTC) (M86) 4512 32nd Road, North, Arlington, VA 22207. Dy: (703) 556-7740. Res: (703) 533-8408. S: Elaine. Job: VP & Gen Mgr, N.E.T. Federal, Inc. Svc: USA, USMC. Ret: 78. 26 yrs.

BIGGS, Richard D., (CW3) (M59) (Skoshi) 6608 Falling Star Drive, Valley Station, KY 40272. Res: (502) 937-3455. S: Regina. Svc: USA. Ret: 69. 23 yrs.

BISCH, Frederick R., (COL) (M59) (Tim) 8604 Esslinger Court, Huntsville, AL 35802. Dy: (205) 721-6485. Res: (205) 881-3043. S: Marilyn. Job: Subcontract Administrator, Science Applications Int'l Corp. (SAIC). Svc: USA. Ret: 86. 29 yrs.

BISHOP, Gary L., (MAJ) (M82) HHB 69th Ada Bde, Box 57, APO NY 09801. Dy: FRG 931-94228. Res: FRG 9306-2536. S: Licia. Job: Dir, Central TX College, Europe Campus. Svc: USA. Ret: 86. 24 yrs.

BISHOP, Herman H., (COL) (M61) (Bish) 2082 Garden Springs Drive, Lexington, KY 40504. Res: (606) 277-4897. S: Geneva. Svc: USA, USN. Ret: 84. 31 yrs. Past VP.

BISSELL, Norman M., (COL) (M74) (Mike) 160 Peace Acre Lane, Stratford, CT 06497. Dy: (203) 386-7943. Res: (203) 378-4058. S: Jan. Job: Dir Government Integrated Logistics Support, Sikorsky Aft. Svc: USA. Ret: 87. 26 yrs. VP, Contract Chapter. Past Pres, Morning Calm Chapter.

BLACK, William G., (COL) (M58) (Bill) 725 Meadow Lake Drive, Ozark, AL 36390. Res: (205) 774-9488. S: Betty. Svc: USA. Ret: 69. 29 yrs.

BLAKER, Michael F., (MAJ) (M83) (Mike) 39905 Dyott Way, Palmdale, CA 93550. Dy: (805) 277-3904. Res: (805) 272-0503. S: Sharon. Job: Chf Flt Ops/Chase Pilot (DAC), Edwards AFB. Svc: USA. 20 yrs.

BLAKELY, Robert W., (MAJ) (M73) (Bob) 8900 Pebble Lane, Oklahoma City, OK 73132. Res: (405) 721-8848. S: Violet. Svc: USA. Ret: 65. 23 yrs.

BLANCHARD, George S., (GEN) (M89) 7713 Lear Road, McLean, VA 22102. Res: (703) 734-1335. S: Beth. Job: Pres, Gen Analysis, Inc. Svc: USA. Ret: 79. 41 yrs.

BLANCHARD, Howard B., Jr, (COL) (M58) (Bud) 308A Forbes Street, Annapolis, MD 21401. Res: (301) 268-3161. Job: Self-employed. Svc: USA. Ret: 79. 31 yrs.

B The SPOOF Roster

BLATT, Donald C., (LTC) (M57) (Don) 3892 50th Avenue South, St. Petersburg, FL 33711. Res: (813) 867-8445. S: Elarie. Svc: USA. Ret: 67. 26 yrs. VP, Suncoast Chapter.

BLEVINS, Wanna W., (MRS.) (M74) 1301 Sandstone Street, Corpus Christi, TX 78412. Res: (512) 992-4226. S: Don. Svc: USA. Ret: 74.

BLOOM, Frank H., (MAJ) (M58) 8475 Pennsylvania Blvd, Fort Myers, FL 33912. Dy: (813) 694-2174. Res: (813) 267-7348. S: Marilyn. Job: Purchasing Mgr, Lee County Mosquito Control Dist.. Ret: 67. 21 yrs. Past VP, Morning Calm Chapter.

BLURBAUGH, Thomas C., (LTC) (M59) 330 Ridge Meadow Drive, Chesterfield, MO 63017. Dy: (314) 553-1211. Res: (314) 576-6560. S: Anita. Job: Mgr, Logistics PM Lab, E&S Div, Emerson Elec. Svc: USA. Ret: 77. 20 yrs.

BOBO, Carl E., Jr, (LTC) (M57) 1402 Fullen Road, Columbus, OH 43229-5149. Dy: (614) 888-5488. Res: (614) 885-5675. S: Mary. Job: Pres, Military/Veterans Educational Foundation, (MILVETS). Svc: USA. Ret: 62. 22 yrs.

BOEHM, William C., (COL) (M60) (Bill) 8605 Highgate Road, Alexandria, VA 22308. Res: (703) 760-1465. S: Reva. Job: Consultant. Svc: USA. Ret: 74. 32 yrs. Past VP, Washington DC Chapter.

BOLAM, Paul F., (LTC) (M63) 6975 South Oswego, Tulsa, OK 74136. Dy: (918) 831-2329. Res: (918) 492-5819. S: Liz. Job: Mgr, Strategic Mktg Burtex/Thomson-CSF. Svc: USA. Ret: 79. 23 yrs.

BOLIN, Darald H., (CSM) (M57) PO Box 931, Apache Junction, AZ 85217-0931. Res: (602) 982-1445. S: Anna. Svc: USA. Ret: 71. 27 yrs. Past VP.

BONASSO, Russell P., (COL) (M58) 6044 Silk Oak Drive, Orlando, FL 32819. Res: (407) 352-1766. S: Eleanor. Job: Pres, Interval Consulting Svc, Inc. Svc: USA. Ret: 69. 27 yrs. 68 McClellan Award.

BONIFACIO, Robert A., (COL) (M57) (Bob) 3941 Tanglewood Circle, Titusville, FL 32780. Res: (407) 268-3288. S: Ellen. Svc: USA. Ret: 82. 37 yrs. Past Pres, Army Avn Center Chapter, 1979 Special Award.

BONNETT, William B., (COL) (M60) (Bill) 6207 51st St Ct W, Tacoma, WA 98467. Dy: (206) 235-2591. Res: (206) 565-8622. S: Nancy. Job: Airport Director, Renton Municipal. Svc: USA. Ret: 86. 29 yrs. Past SR VP, Mount Rainier Chapter.

BOOKMAN, Edmund B. Jr, (LTC) (M54) (Ed) 117 Trombay Drive, Wilmington, NC 28403. Dy: (919) 799-8424. Res: (919) 392-6569. S: Jane. Job: Rep, A.L. Williams & Assoc.. Svc: USA. Ret: 80. 28 yrs.

BORGSTEDE, Charles A., (CW4) (M64) 7857 Zephyr Hills Way, No. Highlands, CA 95660. Res: (916) 723-4471. S: Sara. Job: Lead Saxophonist, Bill Lessman Dance Orchestra. Svc: USA. Ret: 84. 26 yrs.

BOSAN, George S., (COL) (M58) 205 Allendale Way, Camp Hill, PA 17011. Dy: (717) 763-7053. Res: (717) 763-1953. S: Louise.

Job: Dir, Corp. Admn, Hospital Assoc. of PA. Svc: USA. Ret: 76. 30 yrs.

BOURGEIS, Randolph C., (LTC) (M60) (Randy) 110 Beverly Drive, Bay St. Louis, MS 39520. Dy: (504) 257-4186. Res: (601) 467-7792. S: Theresa. Job: Mgr, Video & Publ Svs, Marlin Marietta Manned Space Systems. Svc: USA, USMC. Ret: 75. 30 yrs.

BOURNE, Eldred G., (CWO) (M57) (Pierre) 13501 Chaney Thompson Rd., Huntsville, AL 35803. Dy: (205) 876-2186. Res: (205) 883-9949. S: Rose. Job: Standardization Ofl, USAMICOM, Redstone Arsenal. Svc: USA. Ret: 66. 20 yrs. Past Treas, Greater-Atlanta Chapter.

BOURNE, Harold O., (LTC) (M57) (Hal/Hob) 6415 Carol Ann Drive, Brown Center, WI 53223. Dy: (414) 447-8200. Res: (414) 355-7829. S: Anne. Job: Mgr Of Mktg, Astronautics Corp Of America. Svc: USA. Ret: 80. 30 yrs. Past Sr VP, Rhine Valley Chapter.

BOWDOIN, Arthur C., (LTC) (M61) 1651 E. 8th Street, Stuart, FL 34996. Res: (407) 287-6139. S: Cynthia. Svc: USA. Ret: 77. 24 yrs.

BOWEN, James D., (COL) (M58) 620 So. Independence Ave., Cushing, OK 74023. Dy: (918) 225-7365. Res: (918) 225-0124. S: Louise. Job: Corp Secy, Bray Corp. Svc: USA. Ret: 72. 30 yrs. Past Sr VP, Chesapeake Bay Chapter.

BOYLE, Garrison J. III, (COL) (M57) (Gary) P. O. Box 306, Bowling Green, VA 22427. Dy: (604) 224-9878. Res: (604) 533-6968. S: Julia. Job: Pres, Boyle Service Inc.. Svc: USA. Ret: 75. 34 yrs.

BRADLEY, William C., (COL) (M57) (Bill) 5303 Rich Court, Burke, VA 22015. Dy: (703) 573-9304. Res: (703) 978-5428. S: Nina. Job: Realtor, Town & Country Properties. Svc: USA. Ret: 84. 31 yrs. Life Member.

BRADNER, William L., (COL) (M88) (Bill) 861 Leopard Trail, Winter Springs, FL 32708. Res: (305) 699-0085. S: Marilyn. Svc: USA. Ret: 78. 27 yrs.

BRAMEIER, Charles L., (CW3) (M58) Box 241-Rural Route 2, Rising Sun, IN 47040. Res: (812) 594-2490. S: Dorothy. Job: Farmer. Svc: USA. Ret: 66. 20 yrs.

BRANDENBURG, John N., (LTG) (M59) (John) Route 6, Ivey Drive, Canton, GA 30114. Res: (404) 479-8491. S: Beverly. Svc: USA. Ret: 84. 33 yrs. Past NEB. Past Pres, Air Assault Chapter.

BRANNAN, Robert E. Jr, (LTC) (M58) P.O. Box 693, Stockbridge, GA 30281. Res: (404) 474-8969. S: Esther. Svc: USA. Ret: 66. 26 yrs. Past Sec, Greater-Atlanta Chapter.

BRANSFORD, Thomas, (COL) (M57) (Tom) 1174 Woodland Terrace Trl, Altamonte Springs, FL 32714. Dy: (407) 644-2220. Res: (407) 298-5226. S: Ida. Job: Instruc Vocational School, Orange County School Systems. Svc: USA. Ret: 73. 21 yrs. Past VP.

BRANSTUDER, Phillip V., (MAJ) (M64) (Phil) 11736 Elen Drive, Baton Rouge, LA 70811. Dy: (504) 655-4411. Res: (504) 775-3899. S: Jane. Job: Staff Trainer, LA Dept. Of Corrections, Training Academy. Ret: 77. 25 yrs.

BRANTLEY, Danon L., (LTC) (M58) (Dann) Dynacorp, 2000 Edmund Hally Drive, Reston, VA 22091. Dy: (703) 264-9306. Res: (703) 476-9711. S: Pat. Job: VP Mktg, Support Services Div. Svc: USA, USN, USMC. Ret: 78. 27 yrs.

BRAUN, Julius H., (BG) (M59) (Brownie) 13010 Country Pass, San Antonio, TX 78216. Dy: (512) 829-1800. Res: (512) 494-5907.

BRAZEALE, Charles R., (LTC) (M58) (Chuck) Rr 2, Box 32, Paris, MO 65275. Dy: (816) 327-4181. Res: (816) 327-4818. S: Ina Res. Job: Pres/CEO, Paris Nat'l Bank. Svc: USA. Ret: 77. 20 yrs.

BREM, Homer L., Jr., (LTC) (M63) 2130 Canyon Lakes Drive, San Ramon, CA 94583. Dy: (408) 742-1688. Res: (415) 275-9525. S: Diane. Job: Mgr, Sys Sfty Engrg, Lockheed Missiles & Space Co.. Svc: USA. Ret: 79. 21 yrs.

BRESETE, Allen A., (LTC) (M61) (Al) 7513 Old Oakland Blvd., Indianapolis, IN 46236. Res: (317) 823-4503. S: Fran. Svc: USA. Ret: 80. 30 yrs. Past Tra, Mid-America Chapter.

BRIER, James R., (COL) (M58) (Jim) 2622 East Fountain Street, Mesa, AZ 85213. Dy: (602) 891-8600. Res: (602) 844-7998. S: Nacale. Job: ILS Mgr, APACHE PMO, Douglas Hqtr. Svc: USA. Ret: 86. 31 yrs. Past Pres. Ilesheim Chapter.

BRIGGS, John L., (LTC) (M57) (Johnny) 8 Fairaks, Mineral Wells, TX 76067. Res: (817) 325-6689. S: Mary. Job: Vol, American Red Cross. Svc: USA. Ret: 66. 28 yrs.

BRISTER, Delano R., (LTC) (M62) (Dee) 225 Timberlake Drive, Woodworth, LA 71485. Dy: (318) 448-9673. Res: (318) 473-1013. S: Bennie Sue. Job: Pres, D&B Assoc, Inc. Svc: USA. Ret: 80. 24 yrs.

BRITTON, James H., (MAJ) (M58) 8707 Oak Lodge, San Antonio, TX 78217. Dy: (512) 340-4104. Res: (512) 824-1356. S: Barbara. Job: Owner, Classic Tan Inc. Svc: USA. Ret: 77. 20 yrs.

BRITTON, Weldon C., (LTC) (M57) (Brit) 3511 Mill Creek Road, Haymarket, VA 22069. Dy: (703) 557-5360. Res: (703) 754-9838. S: Martha Su. Job: Operation Chief, FAA, Washington FSDO. Svc: USA. Ret: 70. 28 yrs.

BROCK, Eldridge W., (LTC) (M57) 11110 Surry Place, Chester, VA 23631. Dy: (804) 225-2411. Res: (804) 748-0557. S: Beckie. Job: State Mgmt Consulting Director. Svc: USA. Ret: 75. 22 yrs.

BROCKWAY, George B., (LTC) (M58) (Brock) 7102 No. 17th Drive, Phoenix, AZ 85021. Dy: (602) 995-4120. Res: (602) 995-7327. S: Cathy. Svc: USA. Ret: 64. 22 yrs.

BROFER, Duane R., (COL) (M58) (Brof) 5410 Apache Drive, Sierra Vista, AZ 85535. Dy: (602) 458-3324. Res: (602) 378-2732. S: Joanne. Job: Realtor, Sun Haven Realty. Svc: USA. Ret: 80. 31 yrs. Past VP, Old Tucson.

BROOKS, Daniel H., (LTC) (M81) P.O. Box 11161, Marina Del Rey, CA 90295. VP, Membership Renewal, Southern California Chapter.

BROOKS, Frank B., (MAJ) (M57) 8373 Wilseil St-Northwood, Charleston SC 29418. Dy: (803) 553-6323. Res: (803) 553-6323. S: Julia. Job: Owner, Fleet Mgmt Consultants. Svc: USA. Ret: 64. 20 yrs.

BROPHY, Edward R., Jr., (LTC) (M60) (Ed) 71 Pine Street, Danvers, MA 01923. Dy: (617) 594-1793. Res: (617) 774-8740. S: Ann. Job: Mgr, Logistics MBE, GE. Ret: 73. 20 yrs. Past VP, New York Metro Chapter.

BROWN, Aaron P., (MAJ) (M80) Lear

B The SPOOF Roster

Astronics Corp, 3400 Airport Ave, Santa Monica, CA 90406. Dy: (213) 452-6888. Res: (805) 493-4610. S: Lou. Job: Dir, New Product Development, Lear Astronics Corp. Svc: USA. Ret: 85. 21 yrs. Past Sec, Aloha Chapter.

BROWN, Charles E. Jr., (CW4) (M58) 6815 Spoon Lake, San Antonio, TX 78244. Dy: (512) 652-2598. Res: (512) 661-7351. S: Margaret. Job: Construction Inspector, Dept Of Airforce SARPMA, San Antonio, TX. Svc: USA. Ret: 76. 30 yrs.

BROWN, Charles M., (MAJ) (M80) 1220 Blair Mill Rd, Apt. 1005, Silver Springs, MD 20910. Res: (301) 585-3552. S: Constanita. Svc: USA. Ret: 85. 24 yrs.

BROWN, Chas. L. Jr., (COL) (M59) (Charlie) 1225 Nicole Street, Box 1308, Fort Worth, TX 76112. Dy: (817) 280-8661. Res: (817) 274-8020. Job: Facilities Mgr, Bell Helicopter Textron. Svc: USA. Ret: 88. 30 yrs. Past VP, Lindbergh Chapter.

BROWN, Chas. T., Jr., (LTC) (M58) 18 Beaver Lane, Easton, PA 18042. Dy: (201) 859-6400. Res: (215) 258-7305. S: Lorraine. Job: VP Manufacturing, McGinley Mills. Svc: USA. Ret: 75. 22 yrs. Past VP.

BROWN, Edward C., (LTC) (M64) (Ed) 2128 Hickory Hills Road, Florence, AL 35630. Res: (205) 767-3697. S: Donna. Svc: USA. Ret: 68. 21 yrs.

BROWN, George A., (COL) (M57) 4737 Playfield Street, Annandale, VA 22003. Res: (703) 425-8189. S: Marilyn. Svc: USA. Ret: 84. 30 yrs.

BROWN, Glenn A., (LTC) (M88) 1301 Briarcliff Place, Bel Air, MD 21014. Dy: (301) 678-1449. Res: (301) 836-9133. S: Catharine. Job: Pgm Mgr, Army Programs Rail Co. Svc: USA. Ret: 79. 22 yrs.

BROWN, Howard E., (COL) (M65) (Ed) 100 Beam Road, Enterprise, AL 36330. Res: (205) 347-7348. Ret: 80. 31 yrs. Past Sr VP, Army Avn Center Chapter.

BROWN, John P., (COL) (M58) (Buddy) 4502 Sonata Court, Fairfax, VA 22032. Dy: (703) 652-8000. Res: (703) 978-2711. S: Jeanne. Job: PM, Analytical Sys Engrg Corp. Svc: USA. Ret: 81. 31 yrs.

BROWN, Patty E., (COL) (M63) (Pat) 27 Dunbar Road, Palm Beach Gardens, FL 33418. Dy: (407) 796-7280. Res: (407) 627-7292. S: Becky. Job: Pratt Whitney, Sr. Product Sup Engr. Svc: USA. Ret: 86. 27 yrs. Past Pres, Colonial Virginia Chapter.

BROWN, Richard W., (LTC) (M59) (Dick) 2043 West Coolbrook, Phoenix, AZ 85023. Res: (602) 942-7596. S: Arlene. Svc: USA. Ret: 62. 21 yrs.

BROWNE, Edward M., (MG) (M67) (Ed) 50 O'Connor St, Ste 1500, Ottawa, Ontario, Canada Kip 6I2. Dy: (613) 232-6430. S: Mary Lynne. Job: President, Martin Marietta Canada Ltd. Svc: USA. Ret: 82. 32 yrs. Past Pres, Lindbergh Chapter.

BRUCE, Bobby G., (CW4) (M58) 12376 SW 266 Lane, Homestead, FL 33032. Res: (305) 258-4684. S: Sallie. Svc: USA. Ret: 80. 28 yrs.

BRUNELLE, Pierre V., (COL) (M60) (Pete) 509

Hummingbird Drive, Indialantic, FL 32903. Dy: (407) 773-7200. Res: (407) 777-0282. S: Karen. Job: Realtor Assoc, ERA Pruitt Real Estate. Svc: USA. Ret: 86. 28 yrs.

BRYANS, Wallace A., (LTC) (M79) (Wally) 447 Hillral, Ballwin, MD 63011. Dy: (314) 391-4743. Res: (314) 394-1458. S: Nina. Job: H.S. Teacher & Coach, Parkway School Dist., St. Louis. Svc: USA. Ret: 84. 24 yrs.

BRYANT, Carl E. Jr., (MAJ) (M63) 108 Harwood Place, Enterprise AL 36330. Dy: (205) 598-4974. Res: (205) 347-7878. S: Grace. Job: Asst Dir of Flt, Ft Sity Int'l. Svc: USA. Ret: 72. 21 yrs. Past VP.

BUCHANAN, Annie M., (Ms.) (M87) 10344-H Forest Brook Lane, Creve Coeur, MO 63146. Res: (314) 997-0208. Ret: 87. 34 yrs.

BUCHANAN, Crawford, (COL) (M61) (Buck) 1811 Mill Lane, Dothan, AL 36303. Dy: (205) 792-8783, x248. Res: (205) 793-2872. S: Jean. Job: Dean, School of Bus., Troy St. U at Dothan. Svc: USA. Ret: 78. 32 yrs. Past Pres, Rhine Valley Chapter, AAAA Life Member.

BUCKLEY, Thomas P., (LTC) (M74) (Tom) c/o The Stephens Co., P.O. Box 14516, Houston, TX 77221. Dy: (713) 747-5200. Res: (713) 499-7374. S: Louise. Job: Pres., The Stephens Co. Ret: 83. 21 yrs.

BUCKNER, Boyce B., (LTC) (M58) (Buck) 2809 Cavan Drive, Tallahassee FL 32308. Dy: (904) 893-3262. Res: (904) 893-3262. S: Bonnie. Svc: USA. Ret: 70. 25 yrs.

BUELOW, Wallace R., (COL) (M62) 1061 N. 47th Drive, Show Low, AZ 85901. Res: (602) 537-4938. S: Betty. Svc: USA. Ret: 72. 30 yrs.

BUESSELER, John A., (COL) (M87) 3313 23rd Street, Lubbock, TX 79410-2126. Dy: (806) 743-3201. Res: (806) 792-2974. S: Cathryn. Job: Professor, Texas Tech U Health Sciences Center. Svc: USA, USAF. Ret: 83. 29 yrs.

BULLOCK, Charles A., (COL) (M58) (Chuck) 419 Quail Run Road, Grove, OK 74344. Dy: (918) 786-4434. Res: (918) 786-4853. S: Carolyn. Job: Satellite Coordinator/Psychologist, Grand Lake Mntl Hlth Care Ctr. Ret: 80. 27 yrs. Past Pres, Lindbergh Chapter.

BURBIDGE, John M., (LTC) (M78) (John) 1661 Bob Murphy, El Paso, TX 79936. Dy: (915) 592-7047. Res: (915) 915-6055. S: Sandra. Job: Research Analyst, Research Analyst and Maint, Inc. Svc: USA. Ret: 86. 21 yrs. Past Pres, Stuttgart Chapter.

BURCH, Alvin F., (LTC) (M58) (Floyd) 2721 N.W. Denver, Lawton, OK 73505-3942. S: Nadine. Svc: USA. Ret: 63. 20 yrs. Past VP.

BURDEN, John R., (LTC) (M62) (Jack) 5236 Herzel Woods Court, Fairfax, VA 22032. Dy: (703) 323-5633. Res: (703) 323-6076. S: Jean. Job: President, The Emerald Corp. Svc: USA. Ret: 80. 20 yrs.

BURDESHAW, William B., (BG) (M81) (Bill) 4701 Sangamore Road, Bethesda, MD 20816. Dy: (301) 229-5800. Res: (301) 299-9735. S: Monica. Job: Pres, Burdeshaw Assoc., Ltd.. Ret: 79. 26 yrs.

BURK, Friedrich, (CW4) (M60) (Fred) 6110 Kilhamet Drive, Corpus Christi, TX 78413. Dy: (512) 939-2521. Res: (512) 655-1258. S: Helga. Job: Qual Assur Spc, Metrology, Tmde Spd Coord, Army Depot. Svc: USA. Ret: 74. 20 yrs.

BURNETT, Clark A., (COL) (M58) 206 Laurel

Breeze Drive, Enterprise, AL 36330. Dy: (205) 347-4348. S: Barbara. Svc: USA. Ret: 85. 33 yrs.

BURNS, Joseph C., (COL) (M58) (Joe) 617 Dalby Drive, Brandon, FL 33511. S: (813) 689-2604. S: Sue. Job: Mktg Consultant, UniGlobe Travel Inc. Svc: USA. Ret: 85. 30 yrs.

BURNS, Paul S., (LTC) (M87) 60 Lakeview Drive, Terre Haute, IN 47803. Dy: (812) 237-2665. Res: (812) 877-2485. S: Joan. Job: Assoc Professor, Dept Of Aero Space Tech, Indiana State Univ. Svc: USA. Ret: 89. 21 yrs.

BUTLER, Douthard R., (COL) (M68) (D.R.) 6909 Lamp Post Lane, Alexandria, VA 22306. Res: (703) 768-2093. S: Jo. Svc: USA. Ret: 85. 30 yrs.

BUTLER, James C., (MR.) (M64) (Jim) 7709 St Albans Avenue, St. Louis, MO 63117. Res: (314) 781-9842. S: Geneva. Job: Aerosp Engr, USA AVSCOM. Svc: USA. 4 yrs.

BUTLER, Olva B., (COL) (M58) 1331 Wellington Drive, Baton Rouge LA 70815. Res: (504) 272-0543. S: Janey. Svc: USA. Ret: 74. 32 yrs.

BYARS, Harold W., (LTC) (M88) 108 Rowe Drive, Popponow, VA 23662. Dy: (804) 838-4400. Res: (804) 868-8718. S: Barbara. Job: Organization Analyst, Allen Corp of America. Svc: USA. Ret: 86. 28 yrs.

BYRD, Roger D., (LTC) (M62) 376 Lampighter Lane, Marietta, GA 30067. Res: (404) 953-2708. S: Joyce. Ret: 75. 30 yrs.

CCCCCCCCCCC

CAIN, James D., (CW3) (M86) 1208 N. Crossing Way, Decatur, GA 30033. Dy: (404) 331-4100. Res: (404) 833-1709. S: Louella. Job: Supervisory Auditor, Defense Contract Audit Agency. Svc: USA. Ret: 79. 21 yrs.

CAIN, James F., (CW4) (M59) 636 Overbrook Drive, Fort Walton Beach, FL 32548. Res: (904) 862-1034. S: Iva. Ret: 73. 22 yrs. Past VP, Army Avn Center Chapter.

CALCATERA, Kenneth J., (COL) (M57) 1002 Wheeler Place, Oviedo, FL 32765. Dy: (305) 356-2324. Res: (305) 365-4922. Job: Mgr, Subcontractors, Martin Marietta. Svc: USA. Ret: 78. 26 yrs. Past Sr VP.

CALFOUS, Dennis A. Jr., (CW3) (M65) 39 Woodvale Drive, Branford, CT 06405. Dy: (203) 856-5492. Res: (203) 488-2873. Job: BLACK HAWK ILS Pgm Mgr, Sikorsky Acft, Stratford. Svc: USA. Ret: 79. 28 yrs. Past VP, Connecticut Chapter.

CALHOUN, George B., (COL) (M59) (George) 5160 Hearthstone Lane, Colorado Springs, CO 80919. Dy: (719) 473-7063. Res: (719) 528-1750. S: Jane. Job: Military Planner, High-Altitude & Asso., P.C. Svc: USA. Ret: 84. 32 yrs. Past Pres, Fort Bragg Chapter. AAAA Life Member.

CALKIN, Elroy F., (LTC) (M72) (Red) 9832 Wolcott Drive, Burke, VA 22015. Dy: (703) 644-6018. Res: (703) 250-5248. S: Mikell. Job: Logistics Engr, TRW. Svc: USA. Ret: 84. 24 yrs.

CALLAWAY, Charles P., (LTC) (M58) (Cai) 6294 Larkwood Drive, N.E., Cedar Rapids, IA 52402. Dy: (319) 395-2162. Res: (319) 377-6755. S: Shirley. Job: Mktg Mgr, Rockwell Collins Int'l, Cedar Rapids, IA. Svc: USA. Ret: 76. 24 yrs. Past Treas, Cedar Rapids Chapter.

C

The SPOOF Roster

Past Pres, Rhine Valley Chapter.

CALVERT, Charles L., (COL) (M57) (Charlie) 601 Harbour Master, Shipyard, P.O. 7822, Hilton Head, SC 29938. Dy: (803) 681-4249. Res: (803) 785-3965. S: Vivian. Job: VP, Plantation Housecare Inc. Ret: 81. 31 yrs. Past VP, North Texas Chapter.

CAMP, Julius W., (COL) (M81) (Bruce) 525 Westbury Drive, Grapevine, TX 76051. Dy: (817) 280-8739. Res: (817) 488-1517. S: Donna. Job: Mgr, ILS LHX Pro, Bell Helicopter Textron. Svc: USA. Ret: 86. 27 yrs.

CAMPBELL, James E. Jr., (COL) (M58) (Jim) 1313 Foxfire Drive, Apopka, FL 32712. Dy: (407) 293-1361. Res: (407) 886-7814. S: Virginia. Job: Accountant, Woodlawn Memorial. Svc: USA. Ret: 79. 27 yrs.

CAMPBELL, James T., (MAJ) (M57) (Jim) 906 Harmony Drive, Statesville, NC 28677. Dy: (704) 872-0507. Res: (704) 873-3714. S: Ann. Job: Real Estate Appraiser, Campbell Appraisal Service. Svc: USA. Ret: 73. 20 yrs.

CAMPBELL, John W., (COL) (M58) (Jack) P.O. Box 794, APO NY 09168. Job: Augusta Int'l, Vicenza, Italy. Pgm Mgr. Svc: USA, USN. Ret: 77. 33 yrs. Past Pres, Corpus Christi Chapter.

CAMPBELL, R. Potter., (COL) (M63) (P) Box 402, Melvin Village, NH 03850. Res: (603) 544-9351. S: Betty. Svc: USA. Ret: 68. 27 yrs. Past VP.

CANEY, Charles E., (B6) (M59) (Charlie) 1919 Oakwell Farms Pk200, San Antonio, TX 78218. Dy: (512) 824-9783. Res: (512) 655-7709. S: Fredrica. Job: Registered Rep, USPA/IRA. Svc: USA. Ret: 81. 28 yrs. Past NEB. Past Pres.

CANFIELD, William J., (MAJ) (M84) 519 Albermarle Road, Bricktown, NJ 08724-1152. Job: Elect Engr, AVRADA. Svc: USA. Ret: 80. 22 yrs.

CANTLEBARY, Lee R., (LTC) (M57) (Lee) 4918 Framons Court, Dunwoody, GA 30338. Res: (404) 394-8089. S: Doris. Svc: USA. Ret: 72. 30 yrs.

CANTRELL, William D., (LTC) (M50) (Dale) 2625 Edge-O-Lake Drive, Nashville, TN 37217. Res: (615) 366-6086. S: Wanda. Svc: USA. Ret: 80. 25 yrs.

CARABALLO, Julian T., (LTC) (M84) (Tom) 9616 Ridge Ave, Fairfax, VA 22030-1506. Dy: (703) 683-8783. S: Beverly. Job: DCS Corp, Sr Systems Engr. Svc: USA. Ret: 80. 21 yrs.

CARGEN, Alfred J., (CW3) (M60) (Al) 3946 Starhill Drive, San Antonio, TX 78218. Dy: (512) 829-7233. Res: (512) 599-1712. S: Katie. Job: Avn Safety Mgr, Avn Safety Org. Svc: USA. Ret: 66. 20 yrs. Past VP, Chesapeake Bay Chapter. 76 McClellan Award.

CARLIN, Dennis. (LTC) (M84) 9513 Duffer Way, Gaithersburg, MD 20879. Dy: (301) 946-2664. Res: (301) 926-7782. S: Cindy. Job: Asst VP, Branch Mgr, Guild Mfg Co. Svc: USA. Ret: 87. 21 yrs. Past Sr VP, Schwaebisch Hall Chapter.

CARLISLE, John C., (LTC) (M59) (Jack) 8453 Quail Hollow Road, Indianapolis, IN 46260. Res: (317) 251-7013. S: Sigrid. Svc: USA. Ret: 75. 20 yrs. Past Sec, Greater-Atlanta Chapter.

CARPENTER, Ronald B., (LTC) (M87) (Ron) 3329 E. Fox, Mesa, AZ 85213. Dy: (602) 891-8342. S: Ginny. Job: Mgr, Advanced Concepts. Svc: USA. Ret: 86. 20 yrs.

CARRELL, Alfred C., (MR.) (M63) Route 1, Box 554, Rogersville, MO 65742. Dy: (417) 753-3481. S: Nancy. Svc: USA. Ret: 82. 35 yrs.

CARRILLO, Arnold R., (LTC) (M57) 2705 S. Lands End, Tucson, AZ 85713. Dy: (602) 628-5890. Res: (602) 623-0720. Job: Unit Supv, Vocational Rehabilitation, State Of AZ. Svc: USA. Ret: 75. 29 yrs.

CARROLL, Danford S., (COL) (M83) (Dan) 7404 Starfish Drive, Sarasota, FL 34231-5432. Res: (813) 924-2061. Svc: USA. Ret: 73. 27 yrs.

CARROLL, John E., (MAJ) (M62) 9001 S. Normandale, Apt. 1085, Fort Worth, TX 76116. Dy: (817) 882-5110. Res: (817) 560-0919. Job: Logistics Contr Rep, General Dynamics. Svc: USA. Ret: 73. 20 yrs.

CARSON, Ray M., (COL) (M59) 1380 N. 903 Terrace, Plantation, FL 33322. Dy: (305) 357-6410. Res: (305) 472-1764. S: Mary. Job: Dir., Public Works Dept, Broward County, FL. Svc: USA. Ret: 78. 27 yrs.

CARTER, William C., (LTC) (M57) 910 Catalina Drive, Newport News, VA 23602. Dy: (804) 877-2585. Res: (804) 877-1831. S: Carol. Job: CLU, Carter Associates. Svc: USA. Ret: 70. 20 yrs.

CARVER, Richard W., (1SG) (M63) (Pops) 620 Ridge Circle, Chesapeake, VA 23320. Dy: (804) 468-2245. Res: (804) 436-0670. S: Peggy. Job: Co-owner, Canterbury Day School, Inc.. Svc: USA. Ret: 88. 24 yrs.

CARY, Bruce B., (MAJ) (M75) 33811 9th Avenue South, C/o Rhodes & Fullaway, Federal Way, WA 98003. Dy: (206) 838-8000. Res: (206) 663-2636. S: Kaye. Job: Consultant, Rhodes & Fullaway. Svc: USA. Ret: 88. 21 yrs. Past VP, Morning Call Chapter.

CASHMAN, John N., (CPT) (M86) (Big John) 1637 Beechwood Drive, Martinez, CA 94553. Res: (415) 228-9346. S: Lois. Svc: USA. Ret: 72. 20 yrs.

CASS, Stanley D., (COL) (M58) (Stan) 634 Ash Avenue, Ault, CO 80610. Dy: (303) 834-1231. Res: (303) 834-1231. S: Cecily. Job: President, Cass Farms Co. Svc: USA. Ret: 86. 29 yrs. Past Pres, Tennessee Valley Chapter.

CASSIDY, Robert F., (COL) (M57) (Bob) 10780 Wheatland Avenue, Sunland, CA 91040. Res: (818) 353-4464. S: Diann. Svc: USA. Ret: 65. 26 yrs. Past NEB. Life Member AAAA.

CATRON, Robert L. Sr., (LTC) (M63) (Bob) 4045 Jason Street, New Smyrna Beach, FL 32069. Dy: (904) 239-2331. Res: (904) 428-4142. S: Li-hung. Job: Mgr, Int'l Mktg, GE. Ret: 79. 20 yrs.

CHAIRIS, William R., (MAJ) (M57) 11 Shirley Ann Drive, Ocean Wayside, NJ 07712. Res: (201) 922-9432. S: Patricia. Job: Consultant, Xetron Corp. Svc: USA. Ret: 80. 21 yrs. Past VP, Monmouth Chapter.

CHAMBERLAIN, Donald E., (LTC) (M57) (Don) 3315 Riverview Blvd. W., Bradenton FL 34205. Dy: (813) 792-0077. S: Carol. Svc: USA. Ret: 70. 27 yrs.

CHAMBERS, Harry W., (LTC) (M57) 2145 Heather Glen Drive, Chesterfield, MO 63017. Dy: (314) 469-3590. Res: (314) 532-7753.

S: Lotte. Job: Pres, Systems Test Evaluation Inc. Svc: USA. Ret: 71. 21 yrs. Past Pres.

CHAMBERS, Stanley L., (MAJ) (M57) (Stan) 165 Willow Avenue, Lake Havasu City, AZ 86403. Res: (602) 855-6230. S: Virginia. Job: Asst. State Dir. AZ AARP. Svc: USA. Ret: 61. 23 yrs.

CHAPLIN, Robt. D. III, (LTC) (M65) (Bob) 2720 Whispering Trail C, Arlington, TX 76013. Dy: (817) 280-4137. Res: (817) 274-1239. S: Judy. Job: Engng Specialist, Bell Hqtr Textron. Svc: USA. Ret: 84. 21 yrs.

CHASE, Jean L., (LTC) (M88) 11625 Ne San Rafael, Portland, OR 97220. Dy: (503) 253-5963. S: Mildred. Ret: 61. 21 yrs.

CHESSER, Davis E., (CW3) (M68) Route 1, Box 125-1, Trinity, TX 75882. Dy: (409) 636-7646. Res: (409) 594-5145. S: Sieglind. Job: Ind Supvr V, Texas Dept of Corrections, Lovelady. Svc: USA. Ret: 79. 22 yrs.

CHIN, Bak Y., (LTC) (M60) 733 Gellert Blvd, Daly City, CA 94015. Dy: (415) 995-5055. Res: (415) 878-8977. S: Doris. Job: Mgr, Federal Affirmative Action Program, Western Region, EEOC. Svc: USA. Ret: 72. 20 yrs.

CHRITTON, Wm. R., Jr., (COL) (M58) Route 1, Box 816, West Plains, MO 65775. Dy: (417) 256-0010. Res: (417) 256-3882. S: Wanda. Job: Pres, Air Evac EMS Inc., Svc: USA. Ret: 80. 27 yrs. Past VP.

CHRYSLER, Edward J., (COL) (M81) 12800 Elsinore Drive, Bridgeton, MO 63044. Res: (314) 291-2797. S: Collie. Svc: USA. Ret: 72. 31 yrs.

CHUNN, Don C., Jr., (COL) (M60) 4427 Harbinger, Mesquite, TX 75150. Dy: (817) 280-6596. Res: (214) 270-3275. S: Barbara. Job: Mgr, LHX Trng, Bell Hqtr Textron. Svc: USA. Ret: 84. 26 yrs.

CILEY, Colin D., Jr., (COL) (M59) (Doug) 805 Northside Drive, Enterprise, AL 36330. Res: (205) 347-0235. S: Thinh. Svc: USA. Ret: 77. 32 yrs. Past Sr VP, Army Avn Center Chapter.

CLARK, Carl G., (LTC) (M60) 522 Fenwick Drive, San Antonio, TX 78239. Dy: (512) 735-1500. Res: (512) 656-7981. S: Vangie. Job: Sr VP Investments, Henry S. Miller Co., Svc: USA. Ret: 73. 20 yrs. Past Sr VP.

CLARK, Dan C., (LTC) (M58) 1029 Trailwood Drive, Hurst, TX 76053. Dy: (214) 855-0110. Res: (817) 282-7740. S: Beth. Job: Fort Worth Area Mgr, Countdown Couriers, Inc. Ret: 81. 29 yrs.

CLARK, Davis, (COL) (M59) (Dave) 6100 Rangeline Road, Theodore, AL 36582. Dy: (205) 653-8057. Res: (205) 866-1580. S: Linda. Job: Consultant, Clark Enterprises. Svc: USA. Ret: 84. 37 yrs.

CLARK, Denzel L., (LTC) (M58) Rt 6, Box 91, Killen, AL 35645. Res: (205) 757-4922. S: Vivian. Svc: USA. Ret: 76. 22 yrs.

CLARK, John J., (LTC) (M80) 431 Foudre Lane, Prescott, AZ 86301. Dy: (602) 772-9750. Res: (602) 778-0673. S: Marilyn. Job: Real Est Broker, C21 Prescott Valley. Svc: USA. Ret: 68. 26 yrs.

CLARKE, John P., (MR) (M78) 117 18th Street SE, Long Beach, NC 28465. Res: (919) 278-4860. S: Deanna. Job: President, Clarke Consulting. 3 yrs.

CLARKE, Marshall, (MAJ) (M82) 817 E Gate Dr, Mt Laurel, NJ 08054. Dy: (609) 778-1717.

C The SPOOF Roster

Res: (609) 273-1263. S: Judith. Job: RAYTHEON, Integrated Logistic Support. Svc: USA. Ret: 85. 20 yrs.

CLAY, James E., (LTC) (M73) (Jim) NATO AGARD, APO NY 09777. Dy: (Paris) 011-33-1-47-38-57-65. Res: (Paris) 011-33-1-48-25-54-37. Job: Exec, Avionics Panel Advisory Grp, For Aerospace Research/Dev (AGARD). Svc: USA. 22 yrs.

CLAYBOURN, Guy R. Jr., (LTC) (M57) 1511 Bayshore Drive, P.O. Box 940, Palacios, TX 77465. Res: (512) 972-2270. S: Colleen. Svc: USA. Ret: 68. 25 yrs.

CLUBB, Edwin R., (MAJ) (M65) (Dick) 3220 Orange Avenue, La Crescenta, CA 91214. Dy: (818) 246-3690. Res: (818) 248-3202. S: Donna. Job: Owner/Mgr, Red Carpet Real Estate. Svc: USA. Ret: 78. 20 yrs.

COCKERHAM, Samuel G., (BG) (M58) 512 N. Washington Street, Alexandria, VA 22003. Dy: (703) 549-4370. Res: (703) 451-5977. S: Alice. Job: Pres, Cockerham & Assoc., Svc: USA. Ret: 78. 30 yrs.

COLEMAN, James M., (BG) (M71) (Jim) Box 352, Clinton, MS 39056. Dy: (601) 925-3358. Res: (601) 924-6499. Job: Dean Of Men, Mississippi College. Svc: USA, USN. Ret: 86. 42 yrs.

COLES, Gordon L., (CW4) (M57) 529 South Veach Avenue, Manteca, CA 95336. Res: (209) 823-3936. S: Marian. Svc: USA, USN, USMC. Ret: 68. 29 yrs. Past VP.

COLLINS, Benjamin L., (LTC) (M57) 1377 Glacier Drive, San Jose, CA 95118. Dy: (408) 269-1711. Res: (408) 266-9609. S: Lois. Job: Administrator, Automotive Apprenticeship, Santa Clara City. Svc: USA, USN. Ret: 72. 28 yrs.

COLLINS, Richard C., (LTC) (M79) 11650 Bass Road, Middleville, MI 49333. Res: (616) 795-9447. S: Marilyn. Svc: USA. Ret: 74. 20 yrs.

COZZOLI, Carl A., (LTC) (M57) 5 Short Hills Lane, Pinehurst, NC 28374. Dy: (919) 295-5700. Res: (919) 295-2387. S: Louise. Job: Dir, Harold Stewart Invest. Co., Svc: USA. Ret: 67. 21 yrs. Past Sr VP, North TX Chapter.

COMER, John F., (LTC) (M59) (Jack) 185 Timberlane Drive, Fayetteville, GA 30214. Res: (404) 461-9900. S: Marlene. Svc: USA. Ret: 73. 20 yrs.

CONKLIN, Willard D., (LTC) (M62) (Will) 319 Venetian Way, Hattiesburg, MS 39401. Res: (601) 544-2077. S: Polly. Svc: USA. Ret: 82. 26 yrs.

CONNELL, Thomas E., (COL) (M59) 138 Sandpiper Street, Newport News, VA 23602. Res: (804) 874-1552. S: Charlotte. Svc: USA, USMC. Ret: 83. 31 yrs.

CONNER, Victor, (LTC) (M67) 714 Badger, Harker Heights, TX 76543. Dy: (817) 532-8570. Res: (817) 698-2598. S: Sharon. Job: Program Mgr, McDonnell Douglas Hqtr Co. Svc: USA. Ret: 85. 26 yrs.

CONNORS, Harry L., Jr., (MAJ) (M67) (Dirt) Harry P. Box 332, AFRC Garmisch, APO NY 09053. Dy: (FRG) 08821-3956. S: Heide. Job: Public Affrs Offcr., AFRC Europe. Ret: 83. 20 yrs.

CONRAD, Eugene B., (COL) (M61) (Gene) 203 Plaza Drive, Daleville, AL 36322. Dy: (205) 598-4340. Res: (205) 598-2029. S: Wanda. Job: Avn Safety Consultant, Conrad Ent. Svc: USA. Ret: 72. 32 yrs. Past Pres, Greater-Atlanta Chapter. 70 McClinton.

CONROY, Arthur T. Jr., (COL) (M58) (Art) 6843 Blue Star Drive, McLean, VA 22101. Res: (703) 598-4340. Res: (205) 598-2029. S: Wanda. Job: Avn Safety Consultant, Conrad Ent. Svc: USA. Ret: 72. 32 yrs. Past Pres, Greater-Atlanta Chapter. 70 McClinton.

COOK, Edward B., (MR) (M57) (Ed) 1212 Ash Street, Denver, CO 80220. Dy: (303) 355-9574. Res: (303) 355-9574. S: Mollie. Svc: USA.

COOK, Morris G., (LTC) (M57) (Morrie) 15261 Spring Rd Drive, Chesterfield, MO 63017. Dy: (314) 821-8838. Res: (314) 532-3992. S: Dorothy. Job: Area Mgr, Colonel Mortgage Co., Svc: USA. Ret: 76. 29 yrs.

COOKE, Horace G., (LTC) (M58) 4851 Ravensworth Road, Annandale, VA 22003. Dy: (703) 256-2050. Res: (703) 256-5265. S: Winifred. Job: Mgr, True Value Hardware, Svc: USA. Ret: 63. 21 yrs. Past VP, Washington DC Chapter.

COOPER, Fred. E. III, (COL) (M68) 1695 Hillcrest Lane, Aston, PA 19014. Dy: (215) 591-2505. Res: (215) 459-8830. S: Karlyne. Job: The Boeing Co., Phila., Int'l Mktg. Svc: USA. Ret: 80.

COPELAND, Guy L., (LTC) (M69) 5925 Clermont Landing Ct., Burke, VA 22015. Dy: (703) 471-3044. Res: (703) 250-7964. S: Alice. Svc: USA. Ret: 88. 22 yrs.

CORLEY, William L., (COL) (M57) (Bill) 4500 Old Dominion Drive, Arlington, VA 22207. Dy: (703) 527-3132. Res: (703) 241-1638. S: Regina. Job: Pres/Owner William L. Corley, Real Est., Arlington, Svc: USA. Ret: 77. 22 yrs. Past Sr VP, Phantom Corps Chapter.

CORNEIL, Robert F. Jr., (LTC) (M57) (Bob) P.O. Box 1859, General Delivery, FPO New York 08540. Svc: (000) 081-0500. S: Dec. Svc: USA, USN, USMC. Ret: 67. 23 yrs.

COZZALDO, Ace A., (LTC) (M69) (Ace) 4041 Coppo Road, Hornbrook, CA 96044. Res: (916) 475-3414. Job: Contract Cowboy, Flying Diamond Ranch; Adjunct College History Inst. Svc: USA. Ret: 87. 21 yrs. Past VP, Avn Center Chapter.

CRADDOCK, William P., (LTC) (M57) 1501 Charlott Street, Fort Worth, TX 76112. Res: (817) 451-3120. S: Nancy. Svc: USA. Ret: 65. 22 yrs.

CRAIG, William R., (LTC) (M65) (Bill) 4204 Whipponwill Lane, Plano, TX 75093. Dy: (214) 480-2357. Res: (214) 985-9637. S: Patricia. Job: Mgr, UAV Programs, Defense Syst, Elec Grp, Texas Inst., Svc: USA. Ret: 84. 24 yrs. Past Tra, Leavenworth Chapter.

CRASK, Garnett E., (LTC) (M65) (Gar) 110 Whitfield Street, Athens, AL 35611. Dy: (205) 461-3861. Res: (205) 232-0142. S: Marcia. Job: Boeing. Svc: USA. Ret: 85. 22 yrs. Pres, Tennessee Valley Chapter. Past Sr VP, Rhine Valley Chapter.

CRITCHFIELD, John B., (LTC) (M67) (John) 1408 Craddock Way, Macon, GA 31210. Dy: (912) 788-7416. Res: (912) 474-4162. S: Susan. Job: VP, Acme Business Prod. Svc: USA. Ret: 84. 20 yrs.

CROWWELL, John L., (LTC) (M64) (Louie) 3041 Dona Marta Drive, Studio City, CA 91604.

Dy: (818) 762-7628. S: Ginger. Job: Film Safety Assoc.

CROOK, George R., (COL) (M59) 1030 Fairway Lane, Rockledge, FL 32955. Dy: (407) 784-3092. Res: (407) 636-6212. S: Nancy Ann. Job: Prog Engr, NASA Space Center, Lockheed. Svc: USA. Ret: 80. 26 yrs. Past Pres, Arizona Chapter.

CROOKS, Eugene F., (COL) (M59) (Gene) 2436 Sedgewick Lane, Montgomery, AL 36106. Dy: (205) 271-3940. Res: (205) 277-7125. S: Ruth. Job: Adm. Asst., ABC Board, State of AL. Svc: USA, USMC. Ret: 79. 31 yrs.

CROPP, Ralph C., (MR.) (M60) 7711 Wooddale Lane, Normandy, MO 63121. Res: (314) 521-1735. S: Ruth. Svc: USN. Ret: 83. 20 yrs.

CROUCH, Horace J., Jr., (COL) (M62) (Horace) 1501 South 23rd St, Arlington, VA 22202. Dy: (202) 697-9383. Res: (703) 892-4651. S: Brownie. Job: Dir, Small Bus Progr, Ofc of Sec of Def, Pentagon. Ret: 71. 30 yrs.

CROUCH, Wm. E., Jr., (COL) (M59) (Bill) 1011 Deerpath Road, Dothan, AL 36303. Dy: (205) 598-6316. Res: (205) 794-3268. S: Betty Jane. Job: Mgr, Fort Rucker otc, McDonnell Douglas Hqtr Co. Svc: USA. Ret: 81. 31 yrs. Past NEB. Past Pres, Washington DC Chapter. 1980 Special Award.

CROWELL, W. Bruce, (COL) (M58) (Bruce) 888 Degan Drive, Pt. St. Lucie, FL 34983. Dy: (407) 796-6199. Res: (407) 879-4151. S: Sally. Job: Mgr, Opns & Systems Readiness, T800 PMO, Pratt & Whitney. Svc: USA. Ret: 79. 26 yrs.

CULLINS, Robert B., III, (LTC) (M58) (Bob) 90 Horner Street, Belen, NM 87002. Dy: (505) 864-7488. Res: (505) 864-2789. S: Nancy. Job: Owner-broker, Cullins Realty Co.. Svc: USA. Ret: 78. 21 yrs.

CUMMINGS, Robert C., (COL) (M70) (Bob) 122 Pierce Blvd., O'Fallon, IL 62269. Dy: (618) 452-4341. S: Erma. Past VP.

CUNNINGHAM, Adrian D., (COL) (M58) (Ad) 405 Dolphin Street, Panama City Beach, FL 32413. Dy: (904) 235-3376. Res: (904) 235-3376. S: Ruth. Job: Avn Trng Consultant, Cunningham Avn Trng & Mil Ft Contracting Serv. Svc: USA, USAF. Ret: 78. 35 yrs. Past Sec, Army Avn Center Chapter.

CUNNINGHAM, Hugh S., (MG) (M77) (Hugh) 5623 Sheraton Drive, Fayetteville, NC 28303. Dy: (919) 485-3194. Res: (919) 868-3554. S: Barbara. Job: Owner, Cunningham Enterprises. Svc: USA. Ret: 76. 37 yrs.

CURRY, Blanchard L., (SGM) (M84) (Bill) P. O. Box 4002, La Feria, TX 78559-2401. Dy: (512) 425-1057. Res: (512) 797-3033. S: Yoon. Job: Admin, Acft Logis, CAF. Svc: USA. Ret: 87. 29 yrs.

CURTIS, Danay D., (LTC) (M56) (Dan) 2066 Rurline Drive, St. Louis, MO 63146. Dy: (314) 553-1210. Res: (314) 878-1978. S: Judy. Job: Logistics Mgr, Emerson Electric. Svc: USA. Ret: 84. 20 yrs.

CURTIS, Raymond L., (CW4) (M63) 1118 SE Single Tree Drive, Camas, WA 98607. Dy: (503) 464-6931. Res: (206) 962-4817. S: Jimmie. Job: Turbo Jet Cpt, Pacificorp Trans Inc. Svc: USA. Ret: 84. 27 yrs. Past Sec.

CURTIS, Stanley T., (SFC) (M82) (Stan) 1346 11th Street, Marion, IA 52302-2535. Dy: (319) 395-2839. S: Donna. Job: Rockwell Int'l. Ret: 85. 20 yrs.

D The SPOOF Roster

DAILEY, Charles L., (CW4) (M65) (Chuck) 112 Deal Drive, Newport News, VA 23602. S: Grace. Job: Pilot, VA Dept. Of Avn. Svc: USA. Ret: 84. 26 yrs. Life Member AAAA.

DALRYMPLE, Donald A., (LTC) (M88) (Don) 1 Kensington Court, Williamsburg, VA 23185. Dy: (804) 878-6441. Res: (804) 565-1852. S: Michol. Job: Opns Research/Analysis, American Power Jet Co. Svc: USMC. Ret: 75. 21 yrs.

DANEKER, John G., (CW4) (M58) 15051 Parkside Dr, Sw, No. 5, Ft Myers, FL 33908-4261. Res: (407) 352-0374. Job: Am Soc Safety Engrs, Sr Loss Cntrl Consultant, United Self Ins Svcs. Svc: USA. Ret: 76.

DANIELS, Geoffrey M., (COL) (M58) (Geoff) 2211 Racquet Club Court, Arlington, TX 76017. Dy: (817) 280-3446. Res: (817) 467-3310. S: Norma. Job: Area Mgr, Far East. Bel Hqtr. Svc: USA. Ret: 79. 25 yrs. Past Sr VP, Lindbergh Chapter.

DANIELSON, James D., (MAJ) (M62) (Dan) 17004 Flatwood Drive, Rockville, MD 20855. Dy: (202) 233-6330. Res: (301) 926-4783. S: Laura. Job: Comm Spec, Veterans Admn, Washington, DC. Svc: USA. Ret: 75. 26 yrs.

DANIELSON, Virgil L., (LTC) (M87) (Cotton) 1111 Westview Drive, Ozark, AL 36360. Svc: (205) 774-5586. S: Nell. Job: Consultant. Svc: USA. Ret: 70. 30 yrs.

DANTZER, Laurence L., (LTC) (M57) (Dan) 15869 Buckingham Road, Birmingham, MI 48009. Res: (313) 646-5622. S: Phyllis. Svc: USA. Ret: 85. 23 yrs. Past VP, Army Avn Center Chapter.

DARROUGH, Glenn E., (LTC) (M57) Route 5, Box 242, Candier, NC 28715. Res: (704) 667-3471. S: Thelma. Ret: 63. 25 yrs.

DAVIS, Barrie S., (COL) (M61) 208 West Glenn Street, Zebulon, NC 27597. Dy: (919) 269-7401. Res: (919) 269-4589. S: Ramona. Job: Chm of the Board, Theo Davis Sons, Inc. Svc: USA. Ret: 78. 36 yrs. Past Pres.

DAVIS, G. B., Jr., (MAJ) (M58) Route 3, Box 21, Mineral Wells, TX 76067. Dy: (817) 325-5405. S: Evelyn. Svc: USA. Ret: 65. 22 yrs.

DAVIS, Gerald W., (CW4) (M59) (Gerry) 830 Parque Vista, Bartow, FL 33830-7451. Res: (813) 533-4533. S: Meromay. Svc: USA. Ret: 72. 23 yrs. Past VP, Suncoast Chapter.

DAVIS, Michael M., (COL) (M62) (Mike) 14215 Ridgeboro, San Antonio, TX 78232. Dy: (512) 927-6201. Res: (512) 494-4877. Job: Pres., Excaltair Avn Co. Svc: USA. Ret: 75. 24 yrs.

DAVIS, Robert E., (COL) (M87) (Bob) 942 E. Carmen Street, Tempe, AZ 85283. Dy: (602) 891-3144. Res: (602) 838-7505. S: Shirley. Job: Dept Mgr, Supply & Dept. Maint., McDonnell Douglas Hqtr Co. Svc: USA. Ret: 85. 27 yrs.

DEEL, Arlin, (COL) (M59) (Art) 429 Foxborough Drive, Mountain View, CA 94041. Dy: (408) 756-6727. Res: (415) 965-1949. Job: Subcontract Mgr, Lockheed Missiles & Space Co., Sunnyvale. Svc: USA. Ret: 86. 30 yrs.

DEETS, Robert M., (LTC) (M58) 4101 South Maple, Broken Arrow, OK 74011. Res: (918) 451-0645. S: Opal. Svc: USA, USN. Ret: 69.

25 yrs. Past VP, Army Avn Center Chapter.

DEGENEF, Delano E., (COL) (M59) (Del) 4201 Harbor Woods Road N., Jacksonville, FL 32225. Dy: (703) 366-0003. Res: (904) 642-4880. S: Beverly. Job: Pilot, Piedmont Henson Airlines. Svc: USA. Ret: 84. 31 yrs. Past Pres, Greater-Atlanta Chapter.

DEITCHMAN, Martin, (MR.) (M86) (Marty) 153 Airstale Ave, Long Branch, NJ 07740. Dy: (703) 521-9356. Res: (201) 229-8874. S: Frances. Job: Elec Engr, Nat'l Sys Mgt Corp. Ret: 77.

DELANY, Lawrence D., (SFC) (M80) (Larry) 1129 N. Jackson St., Apt. 308C, Milwaukee, WI 53202-3206. Res: (414) 347-0450.

DENNEY, Robert C., (CW3) (M86) (Bob) 15302 118th Ave Ct E, Puyallup, WA 98374. Dy: (206) 964-1659. Res: (206) 841-1521. S: Hannelore. Job: Field Supvr, Cobro Corp. Svc: USA. Ret: 78. 20 yrs.

DENSFORD, Charles F., Jr., (COL) (M85) (Chuck, Charlie) Route 1, Box 137, Kempner, TX 78639. Res: (817) 542-2443. S: Patsy. Svc: USA, USAF. Ret: 83. 31 yrs.

DESCOTEAU, Rudolph D., (COL) (M58) (Deac) 1101 S Arlington RDG, #1006, Arlington, VA 22202. Dy: (703) 838-5510. Res: (703) 685-0607. S: Ruth. Job: President, Dakota Delaware Co. Svc: USA. Ret: 81. 34 yrs. Past NEB. Past VP, Washington DC Chapter.

DETWILER, Harvey C., (LTC) (M58) 7320 Med Det, Box 2946, APO NY 09131. S: Audrey. Svc: USA. Ret: 81. 28 yrs.

DEWS, Byrd R., (CW4) (M67) 1519 Trevino Drive, Fayetteville, NC 28303. Dy: (919) 396-6420. Res: (919) 488-6548. S: Fran. Job: Air Operations Officer, Simmons Army Airfield, Ft Bragg NC. Svc: USA. Ret: 84. 23 yrs. Past Sec, Greater-Atlanta Chapter.

DIABLE, John Jr., (COL) (M62) (Jack) 467 Bridgetown Court, Satellite Beach, FL 32937. Dy: (407) 773-8369. Res: (407) 773-8369. S: Louise. Job: USMA Admissions Rep, Am Red Cross Chmn. Svc: USA. Ret: 70. 30 yrs. Past NEB.

DICKENS, Raymond E., (COL) (M61) 7502 Clearview Drive, Tampa, FL 33634. Dy: (813) 877-6031. Res: (813) 884-5240. S: Helen. Job: City of Tampa. Svc: USA. Ret: 73. Past Sr VP, Fort Bragg Chapter.

DICKINSON, Roy B., (LTC) (M63) 17201 North Shore Drive, Leavenworth, WA 98826. Dy: (509) 763-3280. Res: (509) 763-3542. S: Pat. Job: Bus Mgr, Two Rivers, Inc. Svc: USA. Ret: 78. 22 yrs. Past Pres, France Chapter.

DICKSON, Richard G., (LTC) (M79) 119 Quail Hollow, Ozark, AL 36360. Dy: (205) 774-3219. Res: (205) 774-4299. S: Carol. Job: Partner, Quark Campers Park. Ret: 86. 20 yrs.

DIETRICH, William A., (MG) (M76) (Bill) Uniformed Svc Benefit Assn, P.O. Box 418258, Kansas City, MO 64141. Dy: (816) 561-2134. Res: (913) 849-6417. S: Mary. Job: Pres., Uniformed Svc Benefit Assoc. Svc: USA, USAF. Ret: 75. 33 yrs.

DIMMERY, Hugh M., (MAJ) (M80) 1827 E. Evergreen St., Mesa, AZ 85203. Dy: (602) 891-8434. Res: (602) 844-3882. S: Valli. Job: Operations Analysis, McDonnell Douglas. Svc: USA. Ret: 86. 20 yrs. Past Sr VP, Checkpoint Charlie Chapter.

DIPBOYE, Richard L., (CW4) (M72) (Rich)

Route 4, Box 451627, Belton, TX 76513. Res: (817) 939-7019. S: Leone. Job: Pilot, Petroleum Hcpr Inc. Svc: USA, USMC. Ret: 87. 23 yrs. Past VP.

DISTEFANO, Joseph, (LTC) (M58) (Joe) 137 Wiffenness Road, Hampton, VA 23669. Dy: (804) 727-3874. Res: (804) 851-8550. S: Patricia. Job: Mgmt Analyst, Hq TRAODC, DCSCD, Ft Monroe. Ret: 62. 26 yrs.

DOBBS, Bobby W., (1SG) (M63) 109 Virginia Drive, Athens, AL 35611. Dy: (205) 837-8780. Res: (205) 232-9040. S: Rosa Marie. Job: JROTC Instr. Bob Jones HS, Madison. Svc: USA. Ret: 71. 21 yrs.

DOBLADO, Edmundo M., (CW4) (M65) (Ed) 2049 Gull Links Road, Sierra Vista, AZ 85635. Dy: (602) 533-5926. Res: (602) 456-3507. Job: Prod Controller, Visual Info Div, Ft Huachuca. Svc: USA. Ret: 79. 30 yrs. Past Pres, Old Tucson.

DODD, Harry J., (MR) (M62) 1437 Silverleaf Lane, St. Louis, MO 63146. Res: (314) 432-8295. S: Thelma. Ret: 61. 20 yrs.

DODRILL, James E., (LTC) (M57) 2150 Plumus Street, Reno, NV 89509. Dy: (702) 789-7476. Res: (702) 827-4127. S: Claudia. Job: Asst VP, Bus Dev, CA Fed Savings & Loan. Svc: USA. Ret: 70. 26 yrs. Past VP, Monmouth Chapter.

DONLEY, Kenneth G., (CW4) (M58) Route 2, Box 11, Salem, AL 36874. Dy: (404) 323-3459. Res: (205) 297-6808. S: Shirley. Job: Chf Pot Patcher, Kentucky Fried Chicken. Svc: USA. Ret: 79. 25 yrs. Past Sec, Alaska Chapter.

DONNELLY, Henry J., (COL) (M67) (Hank) 15 Luzzane Circle, San Anselmo, CA 94960. Dy: (415) 466-3597. Res: (415) 453-5546. S: Dorothy. Job: Medical Dir, US Army-Navy Medical Clinic, Oakland, Letterman Army Med Ctr. Svc: USA. Ret: 77. 26 yrs.

DONOVAN, Edward W., (CW4) (M66) 2103 Friendly Dr, No 3211, Arlington, TX 76011. Dy: (817) 280-3319. Res: (817) 860-4009. Job: General Supervisor Timekeeping, Bell Hcpr. Svc: USA. Ret: 85. 24 yrs.

DORSETT, Michael R., (CW3) (M87) (Mike) 70th Trans Bn, Augusta International, APO NY 96028. S: Soidy. Job: Chief Test Pilot, Augusta Int'l. Svc: USA. Ret: 87. 20 yrs.

DOTY, Benjamin E., (MG) (M65) (Ben) 18911 Saybrook Lane, Huntington Beach, CA 92649. Dy: (714) 896-2179. Res: (714) 840-3998. S: Pat. Svc: USA. Ret: 84. 31 yrs.

DOWNING, Clinton E., (CW4) (M62) (Clint) 600 Starkey Road, No. 807, Largo, FL 34641. Dy: (813) 586-4243. Res: (813) 585-6444. Job: RVP, A.L. Williams Co. Svc: USA. Ret: 80. 26 yrs. Past Sr VP, Aloha Chapter.

DREX, Charles F., (MG) (M60) (Chuck) 3742 Center Way, Fairfax, VA 22033. Dy: (703) 556-2002. Res: (703) 352-0390. S: Lilian. Job: Pgm Mgr, Planning Research Corp. Svc: USA. Ret: 88. 35 yrs. NEB. Past Pres, Corpus Christi Chapter. 78 Special Award.

DRUMWRIGHT, Elton L., (CSM) (M66) Route 1-box 260-a, Montgomery LA 71454. Res: (318) 627-5156. S: Ruth. Job: Maint Chief, 8th Hcpr, Ft. Bragg. Svc: USA, USAF. Ret: 71. 33 yrs. Past VP, Corpus Christi Chapter.

DRYDEN, Gary L., (LTC) (M85) Emerson Electric E&S Div, 8100 Florissant Ave., St. Louis, MO 63136. Dy: (314) 553-2737. Res: (618) 632-7353. Job: Mgr Emerson Electric Co. Svc: USAF. Ret: 81. 26 yrs.

D The SPOOF Roster

DUGGER, Morris W., (COL) (M58) 202 Caddo Drive, Atlanta, TX 75551. Res: (214) 796-5968. S: Eula. Svc: USA. Ret: 73. 29 yrs.

DUKE, Walter, Jr., (LTC) (M83) (Walt) 3536 Roundtable Loop, Owensboro, KY 42303. Dy: (502) 825-6523. Res: (502) 683-4676. S: Betty. Job: Snr Explosive & Blasting Inspector, Commonwealth of KY. Svc: USA. Ret: 70. 22 yrs.

DUNAGAN, Clarence M., (LTC) (M58) (Mike) 435 Wolverine Way, Monument, CO 80132. Dy: (800) 438-3937. Res: (303) 488-3664. S: Sandy. Job: Stock Broker, Fitzgerald, Talman. Ret: 78. 23 yrs.

DUNNE, Robert V., (LTC) (M57) (Bob) 1176 Scarlet Ct, Westerville, OH 43081-4503. Dy: (614) 466-2178. Res: (614) 890-2649. S: Jerry. Job: State Coordinator, Benefit Consultant Agency Inc. Ret: 71. 20 yrs.

DUNNINGTON, Warren H., (LTC) (M61) 5233 Herzell Woods Court, Fairfax, VA 22032. Dy: (703) 450-7580. Res: (703) 978-8605. S: Liz. Job: Div Mgr, USCS ILS Div, Northrop Worldwide Aircraft Svcs, Inc. Svc: USA. Ret: 78. 20 yrs. Past VP, Morning Cabin Chapter.

DYKE, Charles W., (LTJ) (M75) (Bill) 1484 Kirby Road, McLean, VA 22101. Dy: (202) 638-1103. Res: (703) 847-9265. Job: Senior Advisor, Mitsubishi Int'l Corp. Svc: USA. Ret: 88. 34 yrs.

EEEE - FFFF

EADY, Charles L., (CW4) (M83) (Chuck) Box 126, APO SF 96555-0008. Dy: (808) 471-1836 x4157 or AV 254-4157. Res: (808) 471-1836 x4674. S: Jean. Job: Avn Safety Officer, Pan Am World Svcs., Kwajalein Support Proj. Svc: USA. Ret: 86. 28 yrs.

EAKINS, James R., (CW4) (M62) (Jim) 312 South 12½ Street, Vincennes, IN 47591. Dy: (812) 882-7927. Res: (812) 886-9527. S: Carolyn. Job: Controller, Wabash Valley Human Svc, Inc. Svc: USA. Ret: 78. 30 yrs.

EASTERBROOK, Ernest F., (MG) (M57) P.O. Box 50, Carmel, CA 93921. Res: (408) 624-1108. S: Nancy. Svc: USA. Ret: 67. 37 yrs. Past VP, Monterey Bay Chapter.

ECKER, William N., (LTC) (M62) (Bill) 6541 Kiko Street, Diamond Head, Bay St. Louis, MS 39250. Dy: (504) 524-7681. Res: (601) 255-7705. S: Linda. Job: VP, Buck Kreihls Co, Inc. Svc: USA. Ret: 79. 23 yrs. Past Sr VP, Colonial Virginia Chapter.

EDWARDS, Charles A., (COL) (M57) 5903 Mt. Eagle Drive, No. 1404, Alexandria, VA 22303. Dy: (703) 878-9509. Res: (703) 960-0480. S: Laneil. Job: Sr Property Mgr, Gates, Hudson & Assoc. Svc: USA. Ret: 81. 26 yrs. Past Sec, Stuttgart Chapter.

EHLNFELDT, James J., (MR) (M78) (JJ) 815 W. Clay Street, Collinsville, IL 62234. Res: (618) 345-5239. S: Jacqueline. Job: Special Ed Teacher. Svc: USA, USMC. 4 yrs.

ELJASSON, Arne H., (COL) (M57) (Arne) Rt 2, Box 974, McGaheyville, VA 22840. Res: (703) 289-5388. S: Erika. Svc: USA. Ret: 75. 33 yrs. 58 McClellan Award.

ELLIOTT, John W., (COL) (M59) (Jack) 1815 No. Grant Parkway, Miami, OK 74354. Res: (918) 542-2652. S: Wanda Jo. Svc: USA, USAF. Ret: 69. 30 yrs. Past VP, Lindbergh Chapter.

ELLIS, Clarence H., (COL) (M57) (Lance) 740 Capri Blvd, Treasure Island, FL 33706. Dy: (813) 867-0104. Res: (813) 360-8819. S: Betty. Svc: USA. Ret: 72. 32 yrs. Past NEB. Past Pres.

ELLIS, Samuel F., (CW4) (M59) Route 7, Box 40, Harriman, TN 37748. Res: (615) 882-0716. S: Ruth. Svc: USA. Ret: 72. 30 yrs. Past VP, Hanau Chapter.

EMERSON, James E., (CSM) (M80) (Jim) P.O. Box 147, Courtland, CA 95615. Dy: (916) 989-6500. Res: (916) 775-1112. S: Glenda. Job: Adm Asst Citrus Hghts Fire District. Svc: USA. Ret: 85. 25 yrs.

ENGLAND, Marlon F., (COL) (M59) 6055 Knyghton Road, Indianapolis, IN 46220. Res: (317) 255-9193. S: Rita. Job: Self-employed. Ret: 79. 31 yrs.

ENKO, Rodney E., (CW4) (M71) (Rod) 10333 Grouse Road, Lot 28, El Paso, TX 79924. Res: (915) 821-5243. S: Kay. Svc: USAF. Ret: 88. 29 yrs.

ERICKSON, Floyd C., (LTC) (M62) (Eric) 90 Cleveland Rd., Unit 3, Pleasant Hill, CA 94523. Res: (415) 945-6132. S: Frances. Svc: USA. Ret: 67. 28 yrs.

ERNEST, Steven J., (MAJ) (M69) (Steve) 1400 Cedar Oak Lane, Harker Heights, TX 76543. Dy: (817) 526-5115. Res: (817) 699-1400. S: Judy. Job: Realtor, Coldwell-Banker-Wright Real Est. Svc: USA. Ret: 83. 20 yrs.

ESTES, Vernon L., (CW4) (M80) (Vern) 2455 Geo Washington Way, H-142, Richland, WA 99352. Dy: (509) 373-1992. Res: (509) 375-5400. Job: Mgr, Ft Ops, Westinghouse Harford Co. Svc: USA. Ret: 82. 26 yrs.

EVANS, Vernon R., (MAJ) (M88) (Jack) 1307 24th Street, Alamogordo, NM 88310. Res: (505) 437-9001. S: Maureen. Svc: USA. Ret: 69. 23 yrs.

EVINS, Robert O., (LTC) (M59) (Bob) 503 North Green, P.O. Box 847, Marianna, FL 32446. Dy: (904) 526-2544. Res: (904) 482-5116. S: Katherine. Job: Gen Agent, Evins Insurance. Svc: USA. Ret: 68. 23 yrs.

FAAST, Eldon F., (CW4) (M68) (E) 412 Goucher Blvd, Towson, MD 21204. Dy: (301) 485-3900. Res: (301) 337-0799. S: Melva. Job: Chief Pilot, McCall Coal Co, Inc., & McCall Air. Svc: USA. Ret: 86. 30 yrs.

FALCON, James O., (MSG) (M74) (Jim) 2619 Broadwater Ave, Billings, MT 59102. Dy: (406) 652-4995. Res: (406) 652-4995. S: Zonna. Job: Food Service, St Vincent Hospital. Svc: USA. Ret: 86. 27 yrs.

FARRELL, Joseph F., (MSG) (M74) (Jay) 30 Ash Street, Townsend, MA 01469. Dy: (617) 369-5410. Res: (617) 597-8527. S: Ise. Job: Inventory Control, Nuclear Metals, Concord. Svc: USA. Ret: 81. 22 yrs.

FEATHERSTONE, Stephen, (LTC) (M72) (Steve) 3677 E. Oak Rim Way, Salt Lake City, UT 84109. Dy: (801) 972-6995. Res: (801) 272-4666. S: Eva Lou. Job: Pres, S.E. Featherstone & Assoc., Bus. Consultants Grp. Svc: USA. Ret: 75. 21 yrs.

FELLER, Charles L., (CW2) (M81) (Chuck) P.O.

Box 83031, Fairbanks, AK 99708-3031. Dy: (907) 452-2114. Res: (907) 457-3515. S: Nancy. Job: AK State Trooper, Pilot, Dept Of Publ Safety, E Det. Ret: 83. 21 yrs.

FERRIS, Gordon F., (COL) (M59) (Bob) 88A Star Route, Tucker, AR 72168. Dy: (501) 842-2229. Res: (501) 842-2896. S: Elizabeth. Job: Owner, Country Store. Svc: USA. Ret: 75. 22 yrs.

FIELDS, James W., (CW4) (M67) (Jim) 5619 E. Fairfield Street, Mesa, AZ 85205. Dy: (602) 891-4733. Res: (602) 981-9343. S: June. Job: Training Analyst/Designer, McDonnell Douglas Hcpr Co.. Svc: USA, USAF. Ret: 84. 26 yrs.

FIEST, Terrance J., (LTC) (M68) (Terry) GE Co., Tower Box 52, 2101 Executive Drive, Hampton, VA 23666. Dy: (804) 826-9698. Res: (804) 868-6180. S: Roberta. Job: Aerospace Programs Mgr, General Electric Co. Svc: USA. Ret: 86. 27 yrs. Past Sec, Morning Calm Chapter.

FILBY, Robert A., (COL) (M59) (Bob) 2350 Cedar Lake Drive, Maryland Heights, MO 63043. Res: (314) 434-3665. S: Aileen. Svc: USA. Ret: 74. 32 yrs. Past Pres, Lindbergh Chapter.

FILER, Robert E., (COL) (M59) (Bob) 6316 Rockwell Road, Burke, VA 22015. Dy: (703) 941-5607. Res: (703) 455-9797. S: Gladys. Job: Pm, St. Louis Ops, Log Mgmt Eng, Inc.. Svc: USA. Ret: 84. 30 yrs.

FISHER, Walter L., (CW3) (M57) P.O. Box 1151, Benicia, CA 94510. Dy: (415) 869-3886. Res: (707) 746-8678. S: Renate. Job: Customer Supt Rep, Pratt & Whitney Acoft. Svc: USA. Ret: 69. 20 yrs.

FITZSIMMONS, Ronald D., (LTC) (M71) (Ron) 1130 Kildaire Farm Road, Suite 100, Cary, NC 27511. Dy: (919) 467-1882. Res: (919) 469-2627. S: Prudence. Job: Broker, Howard Perry & Walston. Svc: USA. Ret: 84. 22 yrs. Past VP, Coastal Empire Chapter.

FLANAG, John E., (MAJ) (M80) (Voice) 334 University Drive, Radcliff, KY 40160. Dy: (502) 942-8648. Res: (502) 351-3763. S: Anne. Job: Simnet Site Mgr, Perceptronics. Svc: USA. Ret: 86. 20 yrs. Past VP.

FLEHING, E Pearce, Jr., (COL) (M57) 5 Oatline Hill, Columbia, SC 29204. Dy: (803) 782-7247. Res: (803) 782-7247. S: Geraldine. Ret: 68. 31 yrs. Past NEB.

FLETCHER, William F., (LTC) (M63) (Bill) 323 Rolying Wood, Barrington, IL 60010. Dy: (312) 890-8945. Res: (312) 382-2795. S: Nancy. Job: Dist Supv, Chicago Jr ROTC. Svc: USA. Ret: 83. 21 yrs. Past VP, Morning Calm Chapter.

FLOHE, Donald L., (LTC) (M63) (Don) 193 Micanopy Court, Indian Harbour Beach, FL 32937. Dy: (407) 259-0411. Res: (407) 777-0508. S: Joanne. Job: Div Leader, A.L. Williams. Svc: USA. Ret: 81. 21 yrs.

FLUHR, Gilbert W., (CW4) (M67) (Wayne) 3818 Connecticut Street, St. Louis, MO 63116. Res: (314) 664-8563. S: Donna. Svc: USA, USMC. Ret: 86. 23 yrs.

FOLES, Shelton R., (CW4) (M69) (Shel) Route 3, Box 159, Richton, MS 39476. Dy: (601) 545-3800. Res: (601) 964-3416. S: Daris. Job: Pilot, Chain Co, Hattisburg. Ret: 77. 30 yrs. Past VP, Follow Me Chapter.

FOLEY, John G., (CW3) (M84) Sv Galwegh POB 291, Mandeville, LA 70470-0291. Dy: (504) 626-8688. S: Joan. Svc: USA. Ret: 68.

F The SPOOF Roster

23 yrs.

FORD, Eddie L., (LTC) (M57) (Ed) 1706 British Blvd, Grand Prairie, TX 75050. Res: (214) 641-1569. S: Earline. Svc: USA. Ret: 71. 20 yrs.

FORD, Jimmie S., (LTC) (M63) 304 Camelot, Lawton, OK 73501. Dy: (405) 353-5081. Res: (405) 357-0338. S: Pat. Job: Mgr, Reg Otc, Mill Ramts, Litton Data Sys. Svc: USA. Ret: 81. 20 yrs. Past VP.

FOREMAN, Richard G., (CPT) (M58) (Dick) 126 Concord, No. 11, El Segundo, CA 90245. Dy: (203) 215-2150. Res: (203) 640-7818. S: Shirley. Job: Avn Safety Inspector, Gen Avn Operations, FAA LAX F500 23. Svc: USA. Ret: 67. 20 yrs.

FORRESTER, Eugene P., (LTG) (M80) (Gene) 1101 S Arlington Ridge Rd, Arlington, VA 22202. Dy: (703) 521-1250. Res: (703) 486-2390. Job: Int'l Trade Counselor. Svc: USA. Ret: 83. 35 yrs.

FORSYTH, Harry L., (CW4) (M59) 1926 Morningside Drive, Brookings, SD 57006. Dy: (605) 688-5308. Res: (605) 692-2215. S: Charlene. Job: Athletic Director, South Dakota State U. Svc: USA. Ret: 88. 40 yrs.

FOUGERON, Richard A., (CPT) (M86) (Dick) PSC, Box 906, APO NY 09611. S: Mary. Job: B.A.S.I. Field Service Engineer. Svc: USA. Ret: 78. 21 yrs.

FOUNTAIN, Charles D., (COL) (M57) (Chuck) 417 Pelican Bay Drive, Daytona Beach, FL 32019. Dy: (904) 252-5561. Res: (904) 767-9204. S: Nancy Jo. Job: Dir Of Bus, Embry-Riddle Aeron U. Ret: 82. 32 yrs. Past Sr VP.

FOURNIER, Albert L., (COL) (M59) (Al) P.O. Box 187, North Monmouth, ME 04265-0187. Res: (207) 933-4987. S: Doris. Svc: USA. Ret: 86. 28 yrs. Past VP, Colonial Virginia Chapter.

FRAKER, William W., (COL) (M58) (Bill) Route 4 Granburg Place, Gloucester, VA 23061. Dy: (804) 693-0736. S: Ruby. Job: Pres, UPSC, Inc.. Svc: USA. Ret: 80. 26 yrs. Past Pres.

FRANCHINA, Charles T., (LTC) (M57) (Charlie) 4 Granburg Place, San Antonio, TX 78218. S: Marguerite. Svc: USA. Ret: 63. Past Sr VP, North Texas Chapter.

FRANKLIN, Swayne B., (LTC) (M57) 1322 Lake Margaret Drive, Orlando, FL 32806. Res: (407) 851-5768. S: Bettye. Svc: USA. Ret: 70. 26 yrs.

FRANSEEN, Leonard R., (COL) (M58) 850 Viewland Drive, Rochester Hills, MI 48309. Job: Fin Mgr, R&D Tech Cen, Auto Opns, Rockwell Int'l. Ret: 79. 27 yrs.

FRANZO, Geraldine B., (MS.) (M86) (Jerry) 32 Craig Martin Court, St. Charles, MO 63030. Res: (314) 441-6420. S: Larry.

FRANZO, Larry C., Sr., (MR.) (M58) (Larry) 32 Craig Martin Court, St. Charles, MO 63030. Dy: (314) 441-6420. Res: (314) 441-6420. S: Geraldine. Job: Pres, LCF Assoc, St. Louis. Svc: USMC. Ret: 78. Past Sec, Lindbergh Chapter.

FRASER, Harry L., (LTC) (M73) 8315 E 63rd St., Derby, KS 67037-9202. S: Marilyn. Job: Boeing Mill Airplanes. Ret: 85. 31 yrs.

FRAZER, Richard L., (CPT) (M62) (Dick) 4000 Tamarack Trail, Austin, TX 78727. Dy: (409) 971-2455. Res: (512) 255-5415. S: Linda. Job: Pilot, Petroleum Hcprts., Inc.. Svc: USA. Ret: 78. 20 yrs.

FREEMAN, Bobby H., (COL) (M62) (Bob) 120 Deepwood Drive, Hopkinsville, KY 42240. Dy: (502) 439-4141. Res: (502) 886-3440. S: Clarissa. Job: VP, Sovran Bank/Kentucky, Mgr, Ft. Campbell Bank. Svc: USA. Ret: 86. 27 yrs. Past VP, Washington DC Chapter.

FROWNFELTER, James O., (LTC) (M60) 101 Hillview Court, Hurst, TX 76054. Dy: (817) 260-2394. Res: (817) 282-0618. S: Barbara. Job: Dir, Prog Mgmt, Bell Hcpr. Svc: USA. Ret: 75. 23 yrs. Past VP.

FRYE, Richard H., (LTC) (M67) (Dick) SCITEK, 4433 Woodson Road, St. Louis, MO 63134. Res: (503) 929-0017. Res: (314) 423-0884. S: Betty. Job: Ofc Mgr/Sr Analyst, SCITEK (Science & Technology Inc). Svc: USA. Ret: 85. 30 yrs.

FULLER, Melvyn, (LTC) (M57) (Mel) Rd 2, Box 77, So. Royalton, VT 05068. Res: (802) 763-7219. S: Agnes. Svc: USA. Ret: 63. 27 yrs.

FULSANG, Ejner J., Jr., (COL) (M83) (Fang) 24827 Llewellyn Road, Corvallis, OR 97333. Res: (503) 929-3331. S: Dorothy. Job: Municipal Ct Judge, Junction City. Svc: USA. Ret: 75. 38 yrs.

FULTON, Fred F., (COL) (M57) 1919 Green Acres Drive, Montgomery, AL 36106. Res: (205) 279-7359. S: Marcille. Svc: USA. Ret: 72. 30 yrs.

FURNEY, Robert M., (COL) (M60) (Bob) 369 Lighthouse Avenue, Pacific Grove, CA 93950. Dy: (408) 755-4895. Res: (408) 373-0445. S: Mary. Job: Admin Services Ofcr, Monterey City Parks Dept. Svc: USA. Ret: 86. 32 yrs. Past Sec, Fort Bragg Chapter.

FYFFE, Carroll M., (COL) (M60) 1014 Essex Drive, Sierra Vista, AZ 85635. Res: (602) 458-9228. S: Nancy. Svc: USA. Ret: 88. 30 yrs. Past Pres, Nurnberg Chapter.

GGGGGGGGGGGG

GABBERT, Howard M., (COL) (M79) (Corky) Fairchild Weston Sys., Inc. 300 Robbins Lane, Syosset, L.I., NY 11791. Dy: (516) 349-2361. Res: (516) 427-0737. S: Andrea. Job: Dir, Planning. Svc: USA. Ret: 79. 28 yrs.

GAGNE, Joseph R., (CW4) (M67) (Joe) Agusta Teacmo, 70th Trans Co., APO NY 09028. Dy: ETS 382-4126. Res: 11-49-6201-74397. S: Len. Job: Agusta Int'l, BLACK HAWK Test Pilot. Ret: 83. 24 yrs.

GALE, Paul B., (COL) (M59) 9933 Wood Grouse Court, Burke, VA 22015. Dy: (703) 425-7183. Res: (703) 250-6731. S: Jenny Lynn. Job: Real Estate Mgr, Pardo & Graham. Svc: USA. Ret: 80. 24 yrs. Past Tre, Morning Calm Chapter.

GALLUP, Richard A., (CW3) (M84) 3605 Tealwood Court, Virginia Beach, VA 23456. Dy: (804) 461-8151. Res: (804) 431-2591. S: Jacqueline. Job: Sales Mgr, Prudential. Ret: 86. 23 yrs.

GANT, Preston G., (LTC) (M59) (Sam) 4008 Reka Drive-Unit E5, Anchorage AK 99508. Res: (907) 333-0595. S: Agnes. Svc: USA. Ret: 68. 22 yrs.

GARDNER, William H., (COL) (M61) (Bill) 1035

East Camino Diestro, Tucson, AZ 85737. Dy: (602) 575-9292. Res: (602) 575-0526. S: Kathleen. Job: Consultant, Grumman Aircraft Systems. Svc: USA. Ret: 82. 25 yrs. Past Pres, Morning Calm Chapter.

GARNER, James A., (CW3) (M57) 627 Robble Court, Aberdeen, MD 21001. Res: (301) 272-2129. S: Ruth. Svc: USA. Ret: 65. 20 yrs.

GAUZE, James E., (COL) (M60) Rt. 3, Box 3306, Kempner, TX 76539. Res: (817) 547-1337. S: Aletha. Job: Student, Southwest TX State Univ. Svc: USA. Ret: 88. 30 yrs.

GEIGES, Elmer B., Jr., (MAJ) (M58) Hg, USAREUR, Box 1539, APO New York 09403. Dy: (622) 157-8084. Res: (062) 234-0680. S: Jeannette. Job: Avn Safety, U.S. Army. Svc: USA, USMC. Ret: 67. 21 yrs. Past VP, Rhine Valley Chapter.

GENTER, Billy V., (LTC) (M64) (Bill) 616 Huntley Heights Drive, Manchester, MO 63021. Dy: (314) 233-9866. Res: (314) 394-1662. S: Donna. Job: Fielding Rep, McDonnell Douglas Hcpr Co. Svc: USA. Ret: 86. 28 yrs.

GIBSON, Claude F., Jr., (SGM) (M75) (Sgt Maj) Route 8, Box 57, Ozark, AL 36560. Dy: (205) 255-3794. Res: (205) 774-4689. S: Brenda J. Job: Admin Officer, USAAVNBD. Svc: USA. Ret: 84. 30 yrs.

GIBSON, Mack L., Jr., (COL) (M68) Box R, American Embassy, APO NY 09800. Dy: (022) 835-4081. S: Kathy. Job: Reg Mgr Europe, Bell Hcpr Textron. Svc: USA. Ret: 84. 29 yrs. VP, Bonn Area Chapter. Past Pres, Bonn Area Chapter.

GILE, Richard E., (LTC) (M58) (Dick) 29701 Windson Lane, Agoura Hills, CA 91301-4071. Dy: (818) 702-4693. Res: (818) 889-0963. S: Mary. Job: Hughes Aircraft Co, Sr Proj Engr. Svc: USA. Ret: 67. 24 yrs. Past VP, Follow Me Chapter.

GILMORE, Edward A., Jr., (CW4) (M57) (Sonny) 109 Auburn Drive, Enterprise, AL 36330. Dy: (205) 255-8218. Res: (205) 347-1710. S: Claire. Job: Maint. Test Pilot, Dyncorp. Svc: USA. Ret: 85. 35 yrs. Past Tre, Army Avn Center Chapter.

GIMPLE, Lloyd A., (COL) (M59) 11406 Paseo Del Oro, N.E., Albuquerque, NM 87111. Res: (505) 296-9336. S: Erika. Job: Quality Assurance Supervisor, City of Albuquerque. Ret: 83. 31 yrs. Past Sr VP.

GLIESZER, Roland M., (MG) (M80) (Ro) 5130 Brittain Dr., St. Petersburg, FL 33715. Res: (813) 866-1339. S: Helen. Job: Consultant, Free Lance Writer. Svc: USA. Ret: 73. 33 yrs.

GLYNN, Michael S., (LTC) (M67) (Mike) R.D. 1, Box 255-A, Mays Landing, NJ 08330. Dy: (609) 484-4138. Res: (609) 653-1882. S: Patricia. Job: Pm, Lightning Research, FAA Tech Ctr, City Airport. Svc: USA. Ret: 83. 20 yrs. Past VP.

GODFREY, Thomas J., (LTC) (M65) 11112 Bill Hill Drive, El Paso, TX 79936. Res: (915) 591-2984. S: Mary Ann. Job: Auditor, Free Inc. Ret: 87. 24 yrs.

GOFF, Richard D., (LTC) (M61) (R.D.) 7312 Rolling Hills Blvd., Montgomery, AL 36116. Dy: (205) 834-1040. Res: (205) 288-3786. S: Neida. Job: Owner/Bus. Counselor, General Bus. Svc: USA. Ret: 75. 20 yrs. Past Sec, Mid-America Chapter.

GOLDSBERRY, James O., (CW4) (M58) Route 1, Box 145, Marquand, MO 63655. Dy: (314)

The SPOOF Roster

783-2285. Res: (314) 783-5854. S: Peggy. Job: Police Officer, Fredericktown. Svc: USA. Ret: 72. 22 yrs. Past Tre, North Texas Chapter.

GOODE, Franklyn C., (COL) (M57) 9442 Chimney Corner, Dallas, TX 75243. Dy: (214) 235-1930. S: Kelly. Job: Nat'l Sales Mgr, Diversified Ind Prod. Svc: USA. Ret: 78. 25 yrs.

GOODWIN, Frederick C., (COL) (M75) (Goodie) 419 Chimney Creek Drive, Lawton, OK 73505. Dy: (405) 357-1020. Res: (405) 357-4196. S: Sis. Job: Pres, Goodwin Sales & Services, Inc. Ret: 72. 36 yrs. Past Pres.

GOODWIN, Norman W., (LTC) (M57) (Goodie) Box 1010 Low, Locust Grove, VA 22058. Res: (703) 972-9924. S: Connie. Job: Real Estate Broker. Svc: USA. Ret: 61. 20 yrs.

GORDY, Terry L., (COL) (M59) (Terry) 3539 Honeycomb Drive, Conyers, GA 30208. Dy: (404) 476-6342. Res: (404) 922-8514. S: Judy. Job: Mgr Battlefield Weapons Rgmts, Rockwell Int'l MSD. Svc: USA. Ret: 81. 23 yrs. VP, Greater-Atlanta Chapter.

GORDYN, Rudolph J., (CW4) (M78) (Rudy) P.O. Box 25224, Colorado Springs, CO 80936. Res: (719) 548-0719. Ret: 80. 20 yrs.

GOULD, Roger K., (CW4) (M62) 14617 N. Fairlynn Drive, Fountain Hills, AZ 85268. Dy: (602) 891-3759. Res: (602) 837-1531. S: Linda Sue. Job: Fit Test Data Engr, McDonnell Douglas Hcpr Co. Svc: USA. Ret: 76. 20 yrs. Past VP, Arizona Chapter.

GRADY, William H., (MAJ) (M62) (Bill) 307 Richland Avenue, Enterprise, AL 36330-9669. Res: (205) 347-2937. S: Myra. Job: Chairman, Streamlined Bus. Letters. Svc: USN. Ret: 63. 24 yrs.

GRAEBER, Charles R., (CW4) (M57) (Bob) 207 Bora Bora, Rr 2, Galveston, TX 77554. Res: (409) 938-1204. S: Dorothy. Svc: USA. Ret: 75. 30 yrs.

GRAHAM, Robert L., (LTC) (M58) (Bob) 5300 Portsmouth Road, Fairfax, VA 22032. Dy: (202) 543-5100. Res: (703) 591-2123. S: Diana. Job: Broker/Owner, Investors Realty of Wash, DC. Ret: 77. 28 yrs.

GRAULING, William G., (CW3) (M72) (Bill) 146 S. Bouldin Street, Baltimore, MD 21224. Res: (301) 563-2041. S: Elizabeth. Job: Checker, ILA Local 953. Svc: USA. Ret: 74. 20 yrs. Past VP, Chesapeake Bay Chapter.

GREENE, Gerald R., (LTC) (M65) (Jerry) 2428 N.W. 45th Lane, Gainesville, FL 32605. Dy: (904) 372-5304. Res: (904) 335-1782. S: Beverly. Job: Office Operations Mgr, Materials Office, Fl Dept of Trans. Svc: USA. Ret: 79. 26 yrs.

GREENE, John H., (MAJ) (M57) (Jack) 7480 SW 42nd Place, Davie, FL 33314. Dy: (305) 987-1900. Res: (305) 475-0358. S: Jean. Job: Chief Pilot, Lonestar Industries. Svc: USA. Ret: 71. 24 yrs.

GREENE, Therman R., (COL) (M85) 1608 Robin Hood Drive, Oxford, AL 36203. Dy: (205) 238-8132. Res: (205) 835-1252. S: Patricia. Job: Consultant, ORI. Svc: USA. Ret: 86. 31 yrs.

GREENSPAN, Seymour, (MR.) (M74) (Sy) 21

Cedar Avenue, Long Branch, NJ 07740. Res: (201) 222-2576. S: Helen. Job: Pres, Anmarc Assoc. Svc: USA, USN.

GRESSANG, Daniel S., III, (MAJ) (M59) 101 Jasmine Drive, Ozark, AL 36360. S: Margaret. Job: Instr Pilot, ISI, Inc. Svc: USA. Ret: 75. 20 yrs.

GRETT, Stanley E., (COL) (M85) 308 Windsor Way, Enterprise, AL 36330. Res: (205) 393-1674. S: Gail. Ret: 87. 32 yrs.

GREY, Frank D., Jr., (COL) (M57) 135 Linden Drive, Box 61, Frankfort, IL 60423. Res: (815) 469-5481. S: Betty. Svc: USA. Ret: 70. 28 yrs. Past NEB. Past Pres.

GRIESHOP, David S., (COL) (M85) (Dave) GDS 285, APO SF 96206. Dy: (822) 735-8246. Res: (822) 797-4327. S: Midge. Job: Director, McDonnell Douglas Korea. Svc: USA. Ret: 87. 26 yrs. Past Sr VP, Monmouth Chapter.

GRIFFIN, Charles K., (MAJ) (M72) (Chuck) 2506 Thompson Loop NW, Albuquerque, NM 87104. Dy: (505) 883-4044. Res: (505) 243-1638. Job: Pres, Albuquerque Leasing Corp. Ret: 80. 20 yrs.

GRIFFIN, Turner D., (COL) (M87) (Buck) 2030 Morning Dove Lane, San Antonio, TX 78232. Res: (512) 496-6174. S: Charlotte. Svc: USA. Ret: 84. 26 yrs. Past VP, Stuttgart Chapter.

GRIMES, James W., (LTC) (M85) (Jim) 3513 Pelham Blvd., Port Charlotte, FL 33948. Res: (813) 629-5450. S: Eunice. Job: Realtor Assoc. Svc: USA. Ret: 69. 22 yrs.

GRIMM, Adolph H., (LTC) (M59) (Dolf) 148 Lincoln Road, Winter Haven, FL 33884. Dy: (813) 422-6415. Res: (813) 324-4194. S: Catherine. Job: Sr Army Instructor, JROTC, Haines City Sr Hs. Svc: USA. Ret: 73. 20 yrs.

GROSS, Don A., (COL) (M70) 2220 South 62d Street, Lincoln, NE 68506. Res: (402) 488-9229. Past Sec.

GROTHE, Robert T., (MR.) (M62) (CPT John) 2936 Elmcrest Drive, St. Charles, MO 63301. Res: (314) 946-4758. S: Mary Ann. Job: Logis Mgmt Div, AAH PMO/DARCOM. Svc: USAF. 4 yrs.

GROW, John W., Sr., (MAJ) (M67) 5721 N. Hills Drive, Fort Worth, TX 76117. Dy: (817) 280-3110. Res: (817) 834-3975. S: Gretchen. Job: Supervisor Mill Contracts, Bell Hcpr Textron. Svc: USA. Ret: 81. 21 yrs.

GRUBB, Gary H., (LTC) (M78) 7 Putnam Road, Hudson, NH 03051. Dy: (608) 568-6100. Res: (603) 880-6229. S: Sandy. Job: Senior Systems Analyst, Dynamics Research Corp. Svc: USA. Ret: 88. 22 yrs.

GUARD, Bruce C., (COL) (M85) 105 Fox View Place, Cary, NC 27511. Res: (919) 469-8975. S: Jackie. Job: Chief of Staff, NCGARF.

GUDE, Joseph L., (COL) (M57) (Joe) 4858 Chevy Chase Blvd., Chevy Chase, MD 20815. Dy: (301) 656-4858. Res: (301) 656-4858. S: Helen. Job: SCINTREX. Svc: USA. Ret: 72. 30 yrs. Past NEB.

GUION, James L., (LTC) (M58) (Jim) 4220 Hermitage Road, Virginia Beach, VA 23455. Res: (804) 464-3403. S: Annette. Job: Part-time, Cape Henry Hardware. Svc: USA. Ret: 73. 25 yrs.

GURLEY, William F., (LTC) (M57) (Bill) 505 Cass Street, Port Townsend, WA 98368. Res: (206) 385-2558. S: Carol. Job: Consultant. Svc: USA, USAF, USN. Ret: 69. 20 yrs.

GUST, Daniel G., (COL) (M61) (Dan) Route 3, Box 358, Enterprise, AL 36330. Dy: (205) 347-5046. Res: (205) 347-5046. S: Stell. Svc: USA. Ret: 73. 36 yrs.

GUYRE, James J., (CW3) (M11) (Jay) Steinkalerweg 19, D 5202 Heisterschoss, West Germany. Y: Christel. Job: Tech Consultant, US Affairs, Air Lloyd. Svc: USA. Ret: 86. 20 yrs.

HHHHHHHHHHH

HACKNEY, Ronald L., (MAJ) (M85) (Ron) 9767 Pickwood Drive, Pensacola, FL 32514. Res: (904) 478-5186. S: Bonnie. Job: Pilot. Petroleum Hcpr Inc. Svc: USA. Ret: 88. 20 yrs.

HAFERS, Ernest R., (LTC) (M58) 165 Bel Aire Drive, P. O. Box 7449, Panama City Beach, FL 32413. Res: (904) 234-1196. S: Lemon. 28 yrs.

HAHN, Jerry D., (LTC) (M59) 6101 Charing Drive, Columbus, GA 31909. Res: (404) 322-5749. S: Lynne. Ret: 75. 21 yrs. Past Sr VP, Follow Me Chapter.

HALEY, Robert H., (LTC) (M62) 3118 High Meadows, Abilene, TX 79605. Res: (915) 698-8135. S: Betty. Svc: USA. Ret: 77. 22 yrs.

HALL, David R., (COL) (M67) (Dave) 1460 N.W. 92nd Street, Des Moines, IA 50322. Res: (515) 223-6170. S: Iris. Svc: USA. Ret: 84. 30 yrs.

HAMILTON, Robert L., (CW4) (M64) (Bob) 14 East Main Street, Los Gatos, CA 95030. Dy: (408) 998-3266. Res: (408) 356-5735. S: Carol. Job: Ops, Flight Safety, Ais Hcpr's Ltd. Svc: USA. Ret: 75. 21 yrs. Past NEB. Past Treas, Washington DC Chapter.

HAMLET, James F., (MG) (M58) (Jim) 20 Glenwood Avenue, Trenton, NJ 08618. Res: (609) 695-5960. S: Paulette. Ret: 81. 39 yrs.

HAND, Leo M., (COL) (M62) 703 Ridge Drive, McLean, VA 22101. Dy: (703) 237-8990. Res: (703) 827-8394. S: Odette. Job: VP, Quaddella, Inc., Falls Church. Svc: USA. Ret: 80. 29 yrs. Past Pres, Monmouth Chapter.

HANNUM, Alben G., (LTC) (M58) (Al) 130 Kingspoint Drive, Williamsburg, VA 23185. Dy: (804) 253-2442. Res: (804) 253-1347. S: Loreta. Job: Realtor, Goodman, Segar, Hogan. Ret: 81. 26 yrs.

HANSON, Gerald H., (LTC) (M58) (Jerry) 3122 Hilary Drive, San Jose CA 95124. Res: (408) 377-4118. Svc: USA. Ret: 70. 20 yrs.

HARDY, Raymon L., (LTC) (M67) 415 Willow Road, RR 15, Salisbury, NC 28144. Dy: (704) 634-5905. Res: (704) 636-6119. S: Betty Jo. Job: Sr Instr Jr ROTC, Dave Co HS. Svc: USA. Ret: 81. 21 yrs. Past VP.

HARGREVE, William T., (CW4) (M57) (Willie) 140 Anna Drive, Athens, GA 30606. Res: (404) 543-4390. Svc: USA. Ret: 81. 30 yrs.

HARK, William H., (COL) (M59) (Bill) 4317 Southwood Drive, Alexandria, VA 22309. Dy: (202) 267-3802. Res: (703) 360-4233. S: Claudette. Job: Mgr Aeromed-Standards Div, FAA. Svc: USA. Ret: 76. 20 yrs.

HARLESS, Joe E., Ret., (SFC) (M74) 627 Mansfield Road, Ciebume, TX 76031. Dy: (817) 777-6822. Res: (817) 645-2589. S: Sherrill. Job: ASQC And CMI, Fabrication Inspector, Gen Dynamics, Ft. Worth Div.. Svc: USA. Ret: 80. 21 yrs. Past Treas, Colonial Virginia Chapter.

H The SPOOF Roster

HARRIS, Franklin N., (LTC) (M66) (Frank) 205 N. Main St, Bloomdale, OH 44817. Res: (419) 454-2631. S: Marilyn. Ret: 88. 28 yrs. Past Pres.

HARRIS, Lyman B. Jr., (LTC) (M60) 3241 W St. Brides Circle, Orlando, FL 32812. Dy: (407) 894-5921. Res: (407) 282-8442. S: Carmen. Job: Dist Loss Control Consultant, Amer Mutual Ins.. Svc: USA. Ret: 80. 23 yrs.

HARTERT, Richard A., (LTC) (M59) (Dick) 53 Stanley Drive, Newport News, VA 23602. Dy: (804) 678-5744. Res: (804) 874-2625. S: Jean. Job: Gen Materiel Analyst, USATSCH DCD-MLSD, Ft. Eustis. Svc: USA. Ret: 75. 22 yrs.

HARVEY, Perce P., (MSG) (M63) 272 Exeter Road, Newport News, VA 23602. Dy: (804) 878-6657. Res: (804) 877-8347. S: Yoko. Job: Trng Spec, GS-11, RTD, DTD USAALS, Ft. Eustis. Svc: USA. Ret: 73. 21 yrs.

HATCH, Larry G., (MAJ) (M69) 4702 Canady Court S.E., Olympia, WA 98501. Dy: (206) 753-3155. Res: (206) 491-6486. S: Sue. Job: Safety Compliance Off, Dept Corrections, State Of Wash. Svc: USA. Ret: 65. 21 yrs. Past VP, Aloha Chapter.

HATCHER, Daniel P., (MAJ) (M67) (Dan) 1308 Putnam Blvd, Wallingford, PA 19086. Dy: (215) 591-8230. Res: (215) 874-4684. S: Suzanne. Job: Mgr ILS, V-22, Army Airforce, Boeing Hcpr's. Svc: USA. Ret: 87. 20 yrs.

HATTON, Richard R., (LTC) (M61) (Dick) 5709 Vista Bonita NE, Albuquerque, NM 87111. Dy: (505) 822-7766. Res: (505) 299-0372. S: Diane. Job: Principle Logis Engr, Honeywell Inc. Svc: USA. Ret: 74. 20 yrs.

HAUSMAN, James H., (CW3) (M74) (Jim) 101 Blake Drive, Ozark, AL 36360. Dy: (205) 255-5352. S: Edna. Job: Ft. Rucker, AL; Test Pilot, Dyncorp. Svc: USA. Ret: 85. 21 yrs.

HAY, James R., (COL) (M64) (Jim) 8329 Orange Court, Alexandria, VA 22309. Dy: (609) 722-3790. Res: (703) 360-7972. S: Sue. Job: Mgr, Prog Dev, RCA-MSR. Svc: USA. Ret: 81. 26 yrs. Past Treas, Stuttgart Chapter.

HAYES, David B., (LTC) (M82) 615 Northgate Road, Aberdeen, MD 21001. Dy: (301) 272-4800. Res: (301) 272-2220. S: Ursula. Job: Realtor, The Curry Agency. Svc: USA. Ret: 70. 23 yrs.

HAYES, Patrick H., (CW4) (M58) (Pat) 5575 Eisenhower Drive, Lawton, OK 73505. Res: (405) 536-3285. S: Norma. Ret: 73. 20 yrs.

HAYS, Robert O., (COL) (M65) (Bob) 1809 Julia May, El Paso, TX 79935. Res: (915) 593-1410. S: Barbara. Svc: USA. Ret: 86. 28 yrs.

HEAD, Franklin, (CSM) (M87) 1049 E. Stanford Ave, Gilbert, AZ 85234. Dy: (602) 891-8603. Job: PM, MDHC. Ret: 82. 27 yrs.

HEAD, Robert L., (COL) (M57) (Bob) 210 Walnut Way, Euless, TX 76039. Res: (817) 267-0943. S: Anita. Svc: USA. Ret: 75. 30 yrs.

HEDRICK, Miles C., (LTC) (M63) 103 Lolos Drive, Newport News, VA 23606. Dy: (804) 873-1003. Res: (804) 930-0046. S: Donna. Job: Defense Analyst, MANDEX, Inc.. Svc: USA. Ret: 83. 25 yrs. Past VP.

HEFTER, Raymond R., (MR.) (M76) (Sahib) 405 8th Avenue, Belmar, NJ 07719. Dy: (201) 681-0210. S: Shirley. Svc: USA.

HEGDAHL, James O., (COL) (M62) (Jim) 4018 David Lane, Alexandria, VA 22311. Dy: (703) 845-2323. Res: (703) 871-6923. S: Connie. Job: Administrative Officer, Inst. for Def. Analyses. Ret: 80. 26 yrs.

HEINS, Milton H., (MAJ) (M57) (Mik) 1711A Collins Road, Buckley, WA 98321. Res: (206) 829-0511. S: Lou Ann. Svc: USA. Ret: 68. 21 yrs.

HELY, Joseph W., (LTC) (M57) (Joe) 411 Brooktree Drive, Ballwin, MO 63011. Dy: (314) 925-5271. Res: (314) 227-1095. S: Mary Alice. Job: Dir Logis Spt, Harpoon, McDonnell Douglas Astronautics. Svc: USA. Ret: 64. 22 yrs.

HEMINGWAY, Jack W., (BG) (M59) (Kileen) TX 76540. Dy: (817) 690-3311. Res: (817) 698-6708. S: Shirley. Job: Municipal Judge, City of Kileen. Svc: USA. Ret: 72. 30 yrs. Past NEB. Past VP, AAAA.

HENDERSON, Joseph E., (LTC) (M59) (Joe) P.O. Box 566, Pawleys Island, SC 29585. Dy: (803) 237-4269. Res: (803) 237-9080. S: Harriet. Job: Owner/CEO, Henderson Mgmt Gp, Pawleys IS.. Svc: USA. Ret: 69. 27 yrs. Past Pres, Colonial Virginia Chapter.

HENDRICKSON, Donald E., (LTC) (M63) (Don) 1419 Marselle Place, Dallas, TX 75204. Dy: (214) 573-8401. Res: (214) 821-2402. S: Margaret. Job: Mgr, Engrng, Yemen Hunt Oil Co. Svc: USA. Ret: 80. 25 yrs.

HENDRICKSON, Paul L., (MR.) (M60) (Paul) 36 Telluride, St. Peters, MO 63376. Res: (314) 928-0359. S: Elaine Marie. Job: Consultant, Aviation Logistics. Svc: USA. 8 yrs. Past NEB. Past Pres, Lindbergh Chapter. DAC of Year 1985.

HENEVELD, George A., (CPT) (M72) (Yutz) 311 Oakwood Drive, Enterprise, AL 36330. Dy: (205) 347-4236. Res: (205) 393-2109. S: Peggy. Job: Securities Rep & Insurance Agent, USPA-IRA. Svc: USA. Ret: 86. 20 yrs.

HENRY, William H., Jr., (DR) (M61) (Bill) 2937 Parkview Drive, Thousand Oaks, CA 91362. Dy: (818) 712-2420. Res: (805) 492-5433. S: Fran. Job: Dir, Mgt Divlpt, Lockheed Corp.. Svc: USA. Ret: 80. 27 yrs.

HENSCHEL, Danamore F., (LTC) (M58) (Donny) 9306 Wire Avenue, Silver Spring MD 20901. Dy: (703) 521-9356. Res: (301) 587-4348. S: Shirley. Job: Log Analyst, Nat'l Systems Mgmt Corp. Svc: USA. Ret: 68. 20 yrs. Past Sr VP, Rhine Valley Chapter.

HENSELEN, Richard T., (CW4) (M76) (Rich) 5202 - 40th Street East, Tacoma, WA 98443. Dy: (206) 593-6293. Res: (206) 922-9218. S: Connie. Job: Corrections Off, Pierce Cnty Sheriff Dept. Svc: USA, USAF. Ret: 87. 23 yrs. Past VP, Mount Rainier Chapter.

HENSLEY, James R., (LTC) (M58) (Jim) 3907 Weeks Drive, Kennesaw, GA 30144. Dy: (404) 494-6027. Res: (404) 429-1168. S: Sally. Job: Tooling & Tech Tng Coordinr, Lockheed Aeronautical Systems Co/GA Div. Svc: USA. Ret: 80. 23 yrs.

HENSON, Virgil A., Jr., (LTC) (M58) (Virg) Rte 1, Box 507, Killeen, TX 76542-9712. Dy: (817) 288-9008. Res: (817) 634-4110. S: Linda. Job: Tradoc Test & Expr. Command, DCS Methodology & Analysis. Svc: USA. Ret: 68. 21 yrs.

HESS, Carl L., (CW4) (M63) 306 Briar Cliff Road, Ozark, AL 36360. Res: (205) 774-2643. S: Virginia. Job: Instru FR Instructor, Ft Stry Int'l, FSI Inc. Svc: USA. Ret: 82. 26 yrs. Past VP, Phantom Corps Chapter.

HESE, Walter L., (CSM) (M61) 812 S. Maple, Stuttgart, AR 72160. Res: (501) 673-1742. S: Patsy. Svc: USA. Ret: 72. 26 yrs. Past Sec, Aloha Chapter.

HESTER, Leroy V., (LTC) (M57) 6068 South Elizabeth Way, Littleton, CO 80121. Res: (303) 794-6527. Svc: USA. Ret: 67.

HEUER, Martin, (LTC) (M59) (Marty) 9165 136th Street, North Seminole, FL 34646. Dy: (813) 864-0555. Res: (813) 391-2210. S: Rita. Svc: USA. Ret: 73. 20 yrs.

HIBBS, William N., (LTC) (M64) 107 P.W. West Drive, Deridder, LA 70634. Res: (318) 463-6362. S: Ora. Job: Teacher, Special Ed, Anacostia HS. Ret: 87. 26 yrs. Past Pres, Wings of The Devil Chapter.

HICKS, Herbert O., (CW4) (M63) (Herb) 433 Shoreline Drive, Fayetteville, NC 28311. Dy: (919) 497-1066. Res: (919) 488-5886. S: Earnestine. Job: Field Monitor, Cobro Corp. Svc: USA, USMC. Ret: 86. 35 yrs.

HICKS, Walter G., (LTC) (M80) (Walt) 400 Autumnwood Street, Thousand Oaks, CA 91360. Dy: (818) 700-8995. Res: (805) 492-2685. S: Martha. Job: Dir, Mktg & Contracts Admin. Guidance Technology Inc. Svc: USA. Ret: 83. 21 yrs. Past Secy USAREUR.

HILL, David E., (LTC) (M69) 9402 Starlit Ponds Drive, Fairfax, VA 22032. Dy: (703) 560-4646. Res: (703) 978-7170. S: Jan. Job: Contracts Administrator, Fairfax Opportunities Unlimited, Inc. Svc: USA. Ret: 80. 20 yrs.

HILL, Jack D., (LTC) (M59) (Jack) 101 Lakewood Drive, Enterprise, AL 36330. Dy: (205) 598-6520. Res: (205) 347-4167. S: Jeanne. Job: So Eastern Rep, Sikorsky Acraft. Svc: USA. Ret: 73. 20 yrs.

HILL, James F., (LTC) (M57) (Jim) 3224 Wakefield Drive, Decatur, GA 30034. Dy: (404) 656-6177. Res: (404) 624-7040. S: Sue. Job: Dir of Planning, GEMA, State of GA. Svc: USA. Ret: 75. 31 yrs. Past Pres, Colonial Virginia Chapter.

HINDS, William, (LTC) (M82) (Bill) 22 Summerhill Lane, Manchester, MO 63011. Dy: (314) 553-1201. Res: (314) 878-5552. S: Donna. Job: Emerson Elec, Dir of Logis & Product Support. Svc: USA. Ret: 79. 20 yrs.

HINKLE, Philip M., (COL) (M88) (Phil) 16761 Via Del Campo Ct, San Diego, CA 92127. Dy: (619) 592-2369. S: Sharon. Job: Alcoa Defense Systems Inc. Svc: USMC. Ret: 85. 29 yrs.

HISCOCK, Kenneth N., (MAJ) (M65) (Ken) 15 Helen Drive, Newport News, VA 23602. Dy: (804) 380-4052. Res: (804) 874-5816. S: Brigitte. Job: Sr Buyer, Newport News Ship Building. Svc: USA. Ret: 77. 20 yrs.

HODGE, James R., (LTC) (M80) (Jim) 19190 Doewood Drive, Monument, CO 80132. Dy: (719) 481-3515. Res: (719) 481-2118. S: Daisy. Job: Pres, Stanford Marketing Corp. Ret: 64. 20 yrs.

HOELZ, Darold M., (CW4) (M70) 1420 North 10th Avenue, West Bend WI 53095. Res: (414) 334-4075. S: Margaret. Svc: USA, USN. Ret: 86. 42 yrs.

HOEY, E. Val, (LTC) (M81) 122 Aylesbury Hill,

H The SPOOF Roster

San Antonio, TX 78209. Res: (512) 826-5843. S: Lois. Job: Owner, Val Construction, San Antonio. Svc: USA. Ret: 76. 26 yrs.

HOFFMAN, Glenn F., (LTC) (M59) 2922 Gainesborough, San Antonio, TX 78230. Res: (512) 525-0761. S: Lillian. Job: Farmer. Svc: USA. Ret: 83. 28 yrs.

HOGAN, Wayne C., (COL) (M59) 109 Madrona Park Drive, Stillacoom, WA 98388. Dy: (206) 535-3600. Res: (206) 581-5261. S: Lori. Job: Pres., MMR Financial Services. Svc: USA. Ret: 84. 31 yrs.

HOGAN, Wilbur C., (LTC) (M75) (Skip) 18 St. Albans Drive, Hampton, VA 23669. Dy: (804) 727-2609. Res: (804) 851-3072. S: Fern. Job: Chief Of Cost, Trac, Tradoc Analysis Command. GS: 15. Svc: USA. Ret: 72. 20 yrs.

HOLCOMBE, Albert M., (CW4) (M58) (Al) 564 Earl Drive, Sierra Vista AZ 85635. Dy: (602) 458-6208. Res: (602) 458-6208. S: Virginia. Job: Distributor, Amway Corp. Svc: USA. Ret: 77. 33 yrs.

HOLLODICK, George E., (MSG) (M77) (Bear) 710 N. Harrison Avenue, Cary, NC 27513. Res: (919) 467-7806. S: Teresa. Svc: USA. Ret: 78. 23 yrs.

HOLLOMAN, Robert A., (BG) (M58) (Bob) 2300 Parkview Circle, College Park, GA 30337. Dy: (404) 888-2230. Res: (404) 762-9994. S: Jane. Job: Corp Services Dir, Rollins, Inc. Svc: USA. Ret: 79. 29 yrs.

HOLLOWELL, Paul C., II, (LTC) (M66) 13628 Dornock Court, Herndon, VA 22071. Dy: (703) 284-1740. Res: (703) 689-0789. S: Marilyn. Job: Mgr, Wash Dtc, General Motors Corp. (MVO). Svc: USA. Ret: 86. 22 yrs. Past VP, Phantom Corps Chapter.

HOLMES, Ernest L., (LTC) (M60) (Ernie) 2011 Woodhew Drive, Spring, TX 77386. Dy: (713) 230-6626. Res: (713) 292-1948. S: Clara. Job: Director of Tng, Britt Airways. Svc: USA. Ret: 79. 21 yrs.

HOLT, Billy R., (CW4) (M58) 1715 Sycamore Drive, Benton, KY 42025. Dy: (502) 527-9024. Res: (502) 527-9024. S: Betty. Job: Broker, Life of GA, Paducah, KY. Svc: USA. Ret: 73. 21 yrs.

HOLTZCLAW, Bobby L., (CW4) (M58) Route 2, Box 62, Clark, MO 65243. Res: (816) 456-7432. S: Bonnie. Job: Teacher, Avn Dept, Linn Tech College. Svc: USA. Ret: 74. 20 yrs.

HOLZER, James R., (CW3) (M62) (Jim) 519 Park Place, Newton, KS 67114. Res: (318) 283-9187. S: Barbara. Svc: USA, USN, USMC. Ret: 77. 32 yrs. Past VP, Phantom Corps Chapter.

HOOD, John W., (MAJ) (M65) 103 W. High St., Hancock, MD 21750. Dy: (703) 662-2600. Res: (301) 678-5251. S: Milly. Job: Bus, Mgr, W&W Railroad. Svc: USA. Ret: 78. 23 yrs.

HOOKER, James E., (LTC) (M71) (Jim) Muscat, Department Of State, Washington, DC 20520-2220. Dy: (096) 851-8390. Res: (096) 851-9488. S: Phyllis. Job: USFAA, Avn Safety Insp. Opns Fit Standards Adv to Sullamate of Oman. Svc: USA. Ret: 69. 22 yrs. Past Sec.

HOOKS, William G., (LTC) (M58) 6813 Brewster Drive, Columbus, GA 31904-2569.

Dy: (404) 563-0100. Res: (404) 324-1596. S: Edna. Job: Letter Carrier, US Postal Service. Svc: USA. Ret: 70. 25 yrs.

HORAN, Michael J., (COL) (M59) (Mike) P.O. Box 6104, St. Petersburg Beach FL 33736. Dy: (813) 367-6361. Job: Pres, Horan Realty, Inc. Ret: 76. 24 yrs.

HORTON, Chris A., (CW4) (M63) (Chris) 1500 Hidden Meadow Drive, Cottonwood, TN 37048. Dy: (615) 672-4323. Res: (615) 325-9283. S: Shirley. Job: Quality Assurance Mgr, Almet/Lawnite. Svc: USA. Ret: 87. 28 yrs.

HOUSE, Gordon H., (LTC) (M58) 705 South Georgia, Pittsburg, KS 66762. Res: (316) 231-4118. Svc: USA. Ret: 67. 25 yrs. Past Pres, Mainz Chapter.

HOUSE, James H., (LTC) (M58) (Jim) Rr 1, Box 177-I, Oppomattox, VA 24522. Res: (804) 352-0600. S: Melnu. Svc: USA. Ret: 61. 20 yrs. Past Sr VP, Colonial Virginia Chapter.

HOUSER, John W., (LTC) (M62) 240 Parkmont Court, Roswell, GA 30076. Dy: (404) 321-1967. Res: (404) 993-3616. S: Denise. Job: Pres., Jamestown Management Co. Ret: 77. 24 yrs. Past VP, Greater-Atlanta Chapter.

HOUT, Richard W., (MAJ) (M65) (Dick) 544 Pamlico Street, Columbus, OH 43228. Dy: (614) 228-5263. Res: (614) 878-6569. S: Jo. Job: VP, Eagle Land Title Agency, Inc. Svc: USA. Ret: 77. 20 yrs.

HOWIUS, Jeffery C., (LTC) (M88) (Jeff) 1009 Kingston Drive, Mansfield, TX 76063. Dy: (214) 504-0643. Res: (817) 473-0718. S: Joan. Job: Project Mgr, LTV Missiles Div. Svc: USA. Ret: 87. 20 yrs.

HOWARD, William A., (COL) (M84) (Bill) 5317 Renaissance, Burke, VA 22015. Dy: (703) 892-9333. Res: (703) 978-1427. S: Susan. Job: Mgr, Army Programs, TX Instruments. Ret: 84. 22 yrs.

HOWE, Henry L., (COL) (M85) 1150 Plumwood Ct, Ne, Cedar Rapids, IA 52402. Dy: (319) 395-5631. Res: (319) 373-2458. S: Peggy. Job: Tech Dir, Apache Avionics Integration, Rockwell Collins. Svc: USAF. Ret: 85. 24 yrs.

HOWELL, William A., (LTC) (M57) (Bill) 412 Briar Cliff Road, Ozark, AL 36360. Dy: (205) 774-2815. Res: (205) 774-9152. S: Caroline. Job: Partner/Photographer, Ashley J. Studio. Svc: USA. Ret: 63. 25 yrs. Past Tra, Army Avn Center Chapter.

HOWLETT, Byron P., Jr., (COL) (M59) (By) 14035 Faircox Crossing, San Antonio, TX 78231. Dy: (512) 498-1157. Res: (512) 492-5320. S: Billie-Kite. Job: Dir, Mgt Dev & Admin USAA. Svc: USA, USN. Ret: 82. 36 yrs. Past Pres, Jack H. Dibrell (Alamo).

HOWZE, Hamilton H., (GEN) (M57) (Ham) 5416 Regal Drive, Fort Worth, TX 76132. S: Mary. Svc: USA. Ret: 65. 35 yrs. Past Pres, AAAA.

HOYEM, Sylvan D., (LTC) (M60) (Don) 40 Northgate Drive, Monroe, LA 71201. Dy: (318) 323-8600. Res: (318) 388-3102. S: Dorothy. Job: Chief Pilot, LDS, NET Long Distance Savers. Svc: USAF. Ret: 81. 26 yrs. Past Pres, Schwaebisch Hall Chapter.

HOYT, William C., (CW3) (M59) 3027 Sherman Rd., Pebble Beach, CA 93953. Res: (408) 649-3058. S: Jacqueline. Svc: USA, USN, USMC. Ret: 61. 20 yrs.

HULL, Michael H., (COL) (M59) (Mike) 1825

Eye Street, Nw, Suite 700, Washington, DC 20006. Dy: (202) 785-7490. Res: (703) 893-1665. S: June. Job: Dir, Int'l Bus, Sikorsky Acraft. Svc: USA. Ret: 82. 26 yrs.

HUMES, Richard A., (LTC) (M58) (Dick) 26 Huntington Place, Bal Air, MD 21014. Dy: (301) 838-9467. Res: (301) 838-9467. Job: Owner, Custom Strings Tennis Service. Svc: USA. Ret: 70. 23 yrs. Past VP.

HUMPHREYS, James G., (COL) (M58) (Jim) 170 Via De La Reina, Merritt Island, FL 32953. Dy: (407) 832-1111. Res: (407) 452-2044. S: Anne. Job: Assoc VP, Int'l Ed, Brevard Comm College. Svc: USA. Ret: 76. 25 yrs. Past VP, Mid-America Chapter.

HUNT, Gordon M., (COL) (M58) (Mall) 215 The Maine, Williamsburg, VA 23185. Dy: (804) 229-0231. Res: (804) 229-1384. S: Ann. Job: Senior Analyst, BOM Corp. Svc: USA. Ret: 87. 30 yrs.

HUTCHENS, Douglas L., (COL) (M58) (Doug) 1050 Bramwell Lane, Stone Mountain, GA 30083. Dy: (404) 299-4079. Res: (404) 292-7084. S: Dorothy. Job: Chmn, Schol of Pys, Dekalb College. Ret: 78. 31 yrs. Past VP, Lindbergh Chapter.

HUTCHINSON, Richard L., (CW4) (M84) (Hutch) 7180 Hwy, 95a North, Cantonment, FL 32533. Dy: (904) 567-2780. S: Monique. Job: Commercial Hcpr Pilot, PHL. Svc: USA. Ret: 88. 20 yrs.

HYMAN, Robert D., (LTC) (M57) (Hy) 1075 S. Fraser Way, Aurora, CO 80012. Dy: (303) 340-2206. Res: (303) 696-9144. S: Louise. Job: Admin Supvr, Aurora Police Dept. Svc: USA. Ret: 70. 26 yrs.

IIIIII - JJJJJJ

IHLENFELDT, Bruce O., (LTC) (M58) (6) 6aja Court, Corte Madera, CA 94925. Res: (415) 924-5492. S: Blanche. Svc: USA. Ret: 64. 20 yrs. DAC 1964-1975.

ILLER, Alfred J., Jr., (COL) (M57) (Al) Rt 3, Box 1065, Berryville, AR 72616. Res: (504) 423-3737. S: Marguerite. Svc: USA. Ret: 78. 27 yrs.

IMMAN, Kenneth A., (CW2) (M73) (Ken) Rt 1, Box 15300, Porum, OK 74455. Res: (918) 484-2180. S: Sus. Job: Bldg Mgr, American Legion. Svc: USA, USN. Ret: 85. 44 yrs.

IRONS, Richard L., (LTC) (M63) (Dick) 4146 Hickory Drive, Palm Beach Gardens, FL 33418. Dy: (407) 842-4201. Res: (407) 826-9525. S: Judith. Job: Deputy Port Dir, Port of Palm Beach. Svc: USA. Ret: 80. 21 yrs.

ISENHANN, Lester G., (CW4) (M60) (Ike) 6463 Lake Acopla Place, San Diego, CA 92119. Dy: (619) 262-0711. Res: (619) 461-4661. S: Shirley. Job: Sales, Van Waters & Rogers. Ret: 78. 25 yrs.

JABLONSKY, H.J., (MG) (M69) (Jabo) 7400 Crestway, No. 1120, San Antonio, TX 78239. Res: (512) 594-9142. S: Virgie. Svc: USA. Ret: 68. 34 yrs.

JACKSON, Wilfred A., (COL) (M59) (Bill) 944 Tidewater Grove Court, Annapolis, MD 21401. Dy: (301) 859-7022. Res: (301) 266-5411. S: Shirley. Job: Director of Operations, Balt/Wash Int'l Airport. Svc: USA. Ret: 78. 27 yrs. Past Pres.

JACOB, John S., (LTC) (M60) 1642 Ten Mile Lane, Duncannonville, TX 75137. Dy: (214) 330-

The SPOOF Roster

J 9186. Res: (214) 296-4101. S: Merry. Job: Asst Dist Mgr, Curtis Ind, Dallas. Svc: USA. Ret: 77. 26 yrs.

JACOBS, Norman P., (LTC) (M59) (Jake) 109 Collins Drive, Columbia, SC 29212. Dy: (803) 765-6441. Res: (803) 781-4847. S: Dixie. Job: Sr VP, Richland Memorial Hosp. Svc: USA. Ret: 70. 23 yrs.

JACOBSON, Duane M., (CW4) (M64) 115 Oakland Drive, Enterprise, AL 36330. Dy: (205) 255-4576. Res: (205) 393-6242. S: Hillrud. Job: Action Off AGSE, DCD, USAAVNC. Svc: USA. Ret: 77. 22 yrs. Past VP, Redcatcher Chapter.

JACQUAY, Louis H., (LTC) (M74) (Lou) 245 Lullwater Drive, Panama City Beach, FL 32407. Dy: (904) 234-3940. Res: (904) 234-5024. S: Sharon. Job: Dept Mgr, Pacet Systems, Inc. Svc: USA. Ret: 77. 27 yrs.

JAMES, Robert B., (COL) (M62) (Bob) 117 No. Congress Ave., Boynton Beach, FL 33426. Dy: (305) 737-7244. S: W. Helma. Job: Owner, James True Value Hardware. Svc: USA. Ret: 85. 26 yrs.

JAMES, Robert E., (CW4) (M73) 204 W. Hawk Lane, Palmdale, CA 93550. Res: (805) 272-1576. S: Friederick. Job: E-H-60 Flt Ops, Flight Sys Inc, Mojave. Svc: USA. Ret: 85. 21 yrs. Past Sec.

JANSEN, Arlo D., (LTC) (M58) 10209 Cedar Pond Drive, Vienna, VA 22160. Dy: (202) 355-3770. Res: (703) 281-3170. S: Mary Rose. Job: Tech Mgr, Technology Applications. Svc: USA. Ret: 76. 22 yrs.

JANTS, Allan E., (MR) (M68) (Smiley) 1420 Tina Drive, Florissant, MO 63033. Res: (314) 831-8086. S: Mary. Svc: USA. 15 yr.

JARRETT, Richard S., (COL) (M58) (Dick) 1901 Ridgebrook Drive, Arlington, TX 76015. Dy: (817) 280-2359. Res: (817) 465-3488. S: Karlin. Job: Mgr., Middle East Africa, Int'l Mtdg, Bell Hcpr Textron. Svc: USA. Ret: 83. 28 yrs.

JENKS, James E., Jr., (LTC) (M69) (Jim) 111 North Lincoln Court, Port Jefferson, NY 11777. Dy: (516) 563-6822. Res: (516) 331-8199. S: Kathryn. Job: PM, F-14/DIA-6 ATS, Grumman. Svc: USA. Ret: 85. 20 yrs.

JENSEN, Frank L., Jr., (COL) (M58) (Frank) 15805 Vista Drive, Dumfries, VA 22026. Dy: (703) 683-4646. Res: (703) 670-4202. S: Leda. Job: Pres, HAI. Svc: USA. Ret: 74. 31 yrs. Past Pres, Washington DC Chapter.

JERNIGAN, Cecil L., (COL) (M64) 12105 Caddy Row, San Diego, CA 92128. Dy: (619) 268-1100. Res: (619) 485-8146. Job: Gen Mgr, Televideo. Svc: USA. Ret: 81. 21 yrs.

JERSEY, Donald H., (COL) (M58) (Don) 8027 Lauderdale Road, SW, Huntsville, AL 35802. Dy: (205) 536-4024. Res: (205) 883-9371. S: Claudia. Job: Owner/CEO, Shamrock Sports & Co. Svc: USA, USAF. Ret: 74. 30 yrs. Past Pres.

JOHNSON, Albert A., Jr., (COL) (M58) (Al) 107 Caroline Street, Scott, LA 70583. Dy: (318) 261-8575. Res: (318) 232-8362. S: Miriam. Job: Ops/Maint Mgr, City Of Lafayette. Svc: USA. Ret: 74. 35 yrs. Past Pres, Coastal Empire Chapter.

JOHNSON, Benj. F., III, (COL) (M75) (Bliff) 11 Lahn Lane, Mays Landing, NJ 08330. Dy: (609) 825-6000. Res: (609) 484-9144. S: Rosalie. Job: Dir Govt Mil Prog, Airwork Corp. Svc: USA. Ret: 85. 27 yrs. Past VP, Lindbergh Chapter.

JOHNSON, Carl C., (COL) (M58) 11812 Triple Crown Road, Reston, VA 22091. Res: (703) 860-0771. S: Nancy. Svc: USA. Ret: 78. 30 yrs. Past VP, Washington DC Chapter.

JOHNSON, Clifford E., (LTC) (M59) (Cliff) 3249 Jettings Drive, Columbus, GA 31909. Dy: (404) 323-4199. Res: (404) 327-6060. S: Loretta. Job: Pilot/Avn Dept, Columbus Foundries. Svc: USAF. Ret: 70. 23 yrs. Past Pres, Old Tucson.

JOHNSON, David S., (COL) (M58) (Dave) 10815 Colvos Drive, Nw, Gig Harbor, WA 98335. Dy: (206) 851-5852. S: Ellie. Job: Artist, Custom Marine Art. Svc: USA. Ret: 85. 30 yrs.

JOHNSON, Donald K., (MR) (M80) (Don) Rt 5, Box 215-A, Greenville, TN 37743. Res: (615) 636-1888. S: Evelyn. GS: 15. 4 yrs. Svc: USA. 4 yrs.

JOHNSON, Flavil L., (LTC) (M58) 3601 Wharton, Fort Worth, TX 76133. Dy: (817) 625-8855. Res: (817) 294-7998. S: Nell. Job: Prof Aero Tech, Tarrant Co Jr College. Svc: USA. Ret: 70. 28 yrs.

JOHNSON, George T., (CW3) (M79) Beech Aircraft Corp, 202 Miles Avenue, Valley Center, KS 67147. Dy: (316) 681-7528. Res: (316) 755-1551. S: Pamela. Job: Beech Aircraft Corp, Staff Administrator, Pgm Mgmt Office. Svc: USA. Ret: 67. 20 yrs.

JOHNSON, Gerald L., (MAJ) (M82) (Jerry) 103 Coral Way, Route 5, Enterprise, AL 36330. Dy: (205) 347-9392. Res: (205) 347-0612. S: Martha. Job: Avn Life Support Equipment Specialist, Gentex Corp. Svc: USA. Ret: 82. 26 yrs. McClellan Safety.

JOHNSON, L.W., (MAJ) (M87) (Bubba) Hq USCOB/USAB, FMD G3, APO NY 09742-5000. Res: 030-819-7208. S: Shon. Job: Chief, Force Modernization Div, Berlin Brigade. Svc: USA. Ret: 82. 20 yrs.

JOHNSON, Paul H., (CW4) (M58) 312 Willow Oaks Drive, Ozark, AL 36360. Res: (205) 774-5007. S: June. Svc: USA. Ret: 80. 30 yrs.

JOHNSON, Preston B., (MSG) (M81) (P.J.) 2055 Edwards Lake Rd, Greer, SC 29651-8815. Dy: (803) 879-7888. Res: (803) 895-1336. S: Mary Lou. Job: Traffic Mgr, Truck Air of The Carolinas. Svc: USA. Ret: 86. 20 yrs. Past Sr VP, Phantom Corps Chapter.

JOHNSON, Raymond E., (COL) (M57) (Ray) 732 Albion Street, San Diego, CA 92106. Dy: (619) 224-4582. Res: (619) 224-4510. S: Tina. Job: Mgmt Specialist, Avn Ops & Maint. Svc: USA. Ret: 75. 35 yrs. Past Sr VP, Army Avn Center Chapter.

JOHNSTON, Homer W., (LTC) (M76) 10621 Langford Drive, St. Louis, MO 63136. Res: (314) 868-9111. S: Dorothy. Svc: USA. Ret: 63. 20 yrs.

JOHNSTON, Jimmy B., (CW4) (M74) (Jim) P.O. Box 18327, Corpus Christi, TX 78418. Dy: (512) 991-0370. Job: Mr J & Sons Construction. Svc: USA. Ret: 78. 24 yrs.

JOLLEY, Oran B., (MAJ) (M58) 1220 Westlake Road, Cleburne, TX 76031. Res: (817) 556-2053. S: Katie Jean. Ret: 58. 23 yrs.

JONES, Carl R., (MAJ) (M55) 1120 Cleghorn Dr. No. A, Diamond Bar, CA 91765-2325. Dy: (714) 861-2861. Res: (714) 861-2861. Job: Private Investigator, Jones Investigations. Svc: USA. Ret: 75. 21 yrs.

JONES, Charles W., (LTC) (M58) (Chuck) 144 Stockton Avenue, Ocean Grove, NJ 07756. Res: (201) 774-7377. S: Gladys. Svc: USA. Ret: 68. 28 yrs.

JONES, Clyene T., (LTC) (M59) 608 East Spring Valley Rd, Richardson, TX 75081. Res: (214) 690-0915. S: Paula. Svc: USA. Ret: 74. 20 yrs. Past Pres.

JONES, Harold L., (LTC) (M62) (Hal) 1682 Bent River Drive, Luburn, GA 30247. Res: (404) 972-6686. S: Dixie. Job: President, Agency Services, Inc. Ret: 78.

JONES, Harry L., (COL) (M58) 525 Foxgate Ctrs, Chesapeake, VA 23320. S: Florence. Svc: USA. Ret: 74. 33 yrs. Past Pres, Colonial Virginia Chapter.

JONES, Henry W., Jr., (MR.) (M73) (Rocky) 19 Airline Drive, Newport News, VA 23602. Dy: (804) 877-4325. Res: (804) 877-6912. S: Cordelia. Job: Pres, Superchute, Ltd, Gen Engr, Prof'l Air Race Pilot. Svc: USA, USAF. Past Pres.

JONES, Herschel C., (MAJ) (M57) 18 Duggan Road, Acton, MA 01720. Dy: (617) 273-7105. Res: (617) 263-9128. S: Lynn. Job: ROA FIA Manufacturing Inspection Office, Burlington. Svc: USA, USMC. Ret: 67. 24 yrs.

JONES, Luther G. Jr., (COL) (M63) (Jonesy) 725 Brock, Corpus Christi, TX 78412. Res: (512) 982-1637. S: Dorothy. Job: Mayor Emeritus. Svc: USA. Ret: 71. 30 yrs. Past Pres, Corpus Christi Chapter.

JONES, Ralph C., (MAJ) (M72) 107 Cherokee Shores, Northport, AL 35476. Dy: (205) 349-0114/0124. Res: (205) 339-5419. S: Carol. Job: Airport Mgr, Tuscaloosa Municipal Airport. Svc: USA. Ret: 87. 24 yrs.

JONES, Robt. E. Jr., (LTC) (M67) (Gene) 6006 Burnside Landing Dr., Burke, VA 22015. Dy: (703) 739-8071. Res: (703) 250-4428. S: Donna. Job: Sr. Trng Analyst, Allen/Singer-Alexandria. Svc: USA. Ret: 85. 23 yrs.

JONES, Robert J., (LTC) (M63) (Bob) 6247 Turtle Hall Drive, Wilmington, NC 28403-9347. Dy: (919) 259-5763. Res: (919) 256-4613. S: Yvonne. Job: Sr Army Instr/JROTC, Pender Co Board of Ed. Ret: 73. 22 yrs.

JONES, Robert N., (LTC) (M57) 7668 Summerhill Court, Lorton, VA 22079. Dy: (202) 355-2570. Res: (703) 339-5441. S: Sue. Job: Engr IG Rep. Svc: USA. Ret: 73. 20 yrs.

JONES, Walter E., (CW4) (M66) (Walt) 2703 E. Fairfield Circle, Mesa, AZ 85213. Dy: (602) 891-3425. Res: (602) 890-1598. S: Darnell. Job: Ah-64 Prod. TP, McDonnell Douglas Helpr Co. Svc: USA. Ret: 83. 21 yrs.

JORDAN, Donald R., (LTC) (M58) (Don) 1423 Forest Avenue, Neptune Beach, FL 32233. Dy: (904) 744-3950 x461. Res: (904) 246-1372. S: Corky. Job: Asst. Prof. Avn & Bus. & Academic Adv, Coll of Wknd Studies, Jckmsvl Univ. Svc: USA. Ret: 73. 23 yrs. Past Sec, Colonial Virginia Chapter. Past Pres, Morning Calm Chapter.

JOYCE, Donald R., (CW4) (M57) (Don) 219 South Dubin Court, Newport News, VA 23601. Dy: (804) 595-7314. Res: (804) 595-7314. S: Helen. Job: Life & Health Ins. Broker. Svc:

K The SPOOF Roster

USA. Ret: 75. 26 yrs. Past NEB. Past VP, Colonial Virginia Chapter.

JOYCE, Warren C., (LTC) (M58) 213 Bridgewater Drive, Newport News, VA 23603. Res: (804) 887-2445. S: Pat. Job: Reg. Rep, Marson Galleries, Ltd. Svc: USA. Ret: 78. 22 yrs. Past VP, Colonial Virginia Chapter.

JOYNER, Gary W., (LTC) (M64) 313 State St., Geneseo, IL 61254. Dy: (309) 944-5617. Res: (309) 944-4506. S: Jill. Job: Trust Officer, Centrl Trust & Savings Bank. Svc: USA. Ret: 86. 22 yrs. Past Sr VP, Jack H. Dibrell (Alamo).

JUAREZ, Angelo D., (MG) (M83) Cdr, 86th Arcom, 2278 Harvest Lane, Crete, IL 60417. (312) 672-8083. S: Jean.

JUNOT, Arthur J., (BG) (M57) (Art) 605 E. Mary Jane Drive E, Killean, TX 76541. Dy: (817) 634-9954. Res: (817) 634-3268. S: Nan. Job: Pres., Ace, Inc. Svc: USA. Ret: 78. 29 yrs. Past VP, Phantom Corps Chapter.

JUTZ, Donald G., (MAJ) (M57) 1314 S. 76th St. West Allis, WI 53214. Res: (414) 453-0979. Svc: USA. Ret: 68. 20 yrs.

KKKKKKKKKK

KADLEC, Paul W., (BG) (M86) 25675 Tierra Grande Drive, Carmel, CA 93923. Dy: (408) 624-4499. Res: (408) 624-4499. S: Evelyn. Job: VP Mktg, Wels Research Corp, Ft. Collins, CO. Svc: USA, USAF. Ret: 83. 35 yrs.

KAHN, Frank, (MR) (M76) P.O. Box 365, Mineola, NY 11501. Dy: (516) 742-1900. Res: (516) 742-1255. S: Joyce. Job: Sales Engr, Lorton Ind.. Svc: USA. Ret: 49. 9 yrs.

KAISER, Philip E., (LTC) (M62) (Phil) 12650 Verwood Drive, Florissant MO 63033. Dy: (314) 925-5248. S: Joan. Job: Mgr, Field Support, McDonnell Doug. Svc: USA. Ret: 76. 23 yrs.

KALAGIAN, Samuel P., (COL) (M58) (Bik Sam) 314 Sand Creek Drive, Enterprise, AL 36330. Dy: (205) 347-3486. Res: (205) 347-1964. S: Ruby. Job: Assoc Broker, Holly Realty. Svc: USA. Ret: 76. 34 yrs. Past Pres, Alpha Chapter.

KAMBROD, Matthew R., (COL) (M65) (Matt) 5927 Innisville Drive, Fairfax Station, VA 22039. Dy: (703) 239-1538. Res: (703) 250-5335. S: Pat. Job: Defense Consultant. Svc: USA. Svc: USA. Ret: 87. 28 yrs. Past Pres, Washington DC Chapter.

KANE, Ray J., (LTC) (M88) (Bear) 3047 East Leslie Drive, Meridian, ID 83642. Res: (208) 377-8841. S: Judy. Job: Pres, Laid-back Inc. Svc: USA. Ret: 88. 21 yrs.

KAUFFMAN, Lewis E., (COL) (M62) (Ed) 14987 Broadfront Drive, Chesterfield, MO 63017. Dy: (314) 298-0092. Res: (314) 394-3169. S: Carole. Job: Lucas Aerospace Inc, Mgr, St Louis Opns. Svc: USA. Ret: 87. 26 yrs.

KEATING, David W., (COL) (M58) (Dave) Textron Lycoming, Ste 303, 4534 N. Lindbergh Blvd, Bridgeton, MO 63044. Dy: (314) 731-5802. Res: (314) 993-9901. S: Donna. Job: Mgr, St Louis Opns, Textron Lycoming. Ret: 88. 27 yrs. Past Pres, Wings of The Marine Chapter.

KEATING, Richard P., (LTC) (M58) (Dick) 2830 Alton Drive, St. Petersburg, FL 33706. Dy:

(813) 228-2381. Res: (813) 360-7900. S: Geraldine. Job: Asst. Dist. Dir, US Customs Svc. Svc: USA. Ret: 70. 22 yrs. Trea, Suncoast Chapter. Past VP, Suncoast Chapter.

KELLAR, Robert S., (COL) (M59) 176 Bahama Boulevard, Cocoa Beach, FL 32931. Dy: (305) 783-4300. Res: (305) 783-5660. S: Muriel. Job: VP Heritage Real Estate. Svc: USA. Ret: 74. 34 yrs.

KELLEY, Robert D., (LTC) (M65) (Bob) 6520 Rivington Road, Springfield, VA 22152. Dy: (703) 671-9616. Res: (703) 569-3456. S: Pamela. Job: Sr Analyst/Programmer, SAIC. Svc: USA. Ret: 83. 22 yrs.

KELLOGG, Kenneth E., (COL) (M57) (Ken) 18 Aero Estates Drive, Belleville, IL 62223-7001. Dy: (618) 277-5236. Res: (618) 277-5236. S: Midge. Job: Reg Mgr, Beech Aircraft Corp. Svc: USA. Ret: 85. 30 yrs. Past VP, Lindbergh Chapter. Past Sr VP, Lindbergh Chapter.

KELLY, James J., (COL) (M60) (Jim) 58 Willett St. Albany, NY 12210-1111. Dy: (518) 442-5099. Res: (518) 449-4702. S: Carol Ann. Job: Prog. Coordinator, State Univ. of NY/Albany. Svc: USA. Ret: 84. 31 yrs.

KELLY, Patrick J., (LTC) (M84) (Pat) 62 Camelot Apt., Dothan, AL 36303. Res: (205) 793-7418. Job: Primary Instr. Pilot, Ft Stryker Int'l. Svc: USA. Ret: 78. 23 yrs.

KEMP, Freddie L., (LTC) (M59) 6001 Meriwether Lane, Springfield, VA 22150. Res: (703) 971-8397. S: Norma. Svc: USA. Ret: 84. 30 yrs.

KENDIG, Robert L., (COL) (M70) (Bob) Box R, APO NY 09800. Dy: (022) 836-1047. Res: (022) 832-1044. S: Alma. Job: Dir-Europe, UTC Int'l. Svc: USA, USAF. Ret: 70. 30 yrs. Past VP, Bonn Area Chapter.

KENNEDY, Geo. H. III, (CW4) (M67) 2524 S. Laredo Court, Aurora, CO 80013. Dy: (503) 472-0011. Res: (303) 337-4244. S: Mary. Job: FDO-817, Evergreen Int'l Airlines. Svc: USA. Ret: 87. 30 yrs.

KENNEDY, James E., (COL) (M58) (Gmo) 802 Prospect St., No. 206, Honolulu, HI 96813. Res: (808) 538-3363. Job: Student, Electronics. Svc: USA. Ret: 78. 32 yrs.

KENNEDY, Lawrence E., (CSM) (M83) (Rabbit) Route 1, Box 227, Aberdeen, MS 38730. Dy: (601) 256-9321. Res: (601) 256-7005. S: Myra L.. Job: Traffic Mgr, Amco Oil Co.. Ret: 75. 32 yrs. Ret.

KENNEDY, Richard J., (COL) (M58) (Dick) 1887 North Laurel Avenue, Upland, CA 91786. Res: (714) 985-7414. S: Lonne. Job: Consultant. Svc: USA. Ret: 73. 34 yrs. Past Sr VP, Southern California Chapter.

KENNEDY, William J., (BG) (M71) (Bill) 3904 Pebble Path, Austin, TX 78731. Dy: (512) 929-2116. S: Marie. Job: Prog Dir, Tracor Aerospace. Svc: USA. Ret: 79. 30 yrs. Past Pres.

KENOLIO, David N. Jr., (CW4) (M67) (Mr. K) 95-149 Kahala Street, Mililani Town, HI 96789. Dy: (808) 658-2633. Res: (808) 623-4452. S: Olivia. Job: Site Sprvr, Army Aircraft Maint, Lear Siegler Mgmt Svcs Corp.. Svc: USA. Ret: 86. 32 yrs.

KENTON, James H., (LTC) (M73) (Jim) 3293 Clubland Drive, Marietta, GA 30067. Dy: (404) 578-9503. S: Joanne. Job: Chf Pilot, Carey Paul, Inc. Svc: USA. Ret: 86. 20 yrs. Past Pres, Follow Me Chapter.

KENYON, Richard D., (MG) (M61) (Dick) Route 4, Box 1990, Ozark, AL 36380. Dy: (205) 598-0401. Res: (205) 347-3320. S: Ginny. Job: Dir Mgr, Ft Rucker Div, Dyncorp. Svc: USA. Ret: 87. 30 yrs. Past NEB.

KENFOOT, Lester R. Jr., (LTC) (M58) (Les) 6216 Apache Street, Springfield, VA 22150. Dy: (703) 971-5297. Job: Principal Rotorcraft Consultant, SY. Safety Assoc.. Svc: USA. Ret: 77. 26 yrs.

KIBLER, Robert A., (MAJ) (M60) (Bob) 109 N. Lake Street, Ironwood, MI 49938. Dy: (906) 932-9320. Res: (906) 932-2240. S: Jean. Job: Sr JROTC Instr, Ironwood School Dist. Ret: 74. 24 yrs. Past Trea.

KIEFFER, George W., (LTC) (M62) 3016 Pelham Place, Doylestown, PA 18901. Dy: (215) 822-2929. Res: (215) 794-3103. S: Barbara. Job: Dir Transmitter Engrng, AEL. Svc: USA. Ret: 80. 21 yrs.

KIGER, John W., (MAJ) (M61) 605 Tyrone Drive, Leander, TX 78641. Dy: (512) 259-1178. Res: (512) 259-3953. S: Frances. Job: Code Enforcement Official, City of Leander. Svc: USA, USMC. Ret: 71. 26 yrs. Past Trea, Checkpoint Charlie Chapter.

KIMEL, Gerald D., (CW4) (M86) 1 Day Circle, Daleville, AL 36322. Res: (205) 596-6191. S: Gail. Job: Pilot, Big Eye Hcpr, Guam. Ret: 81. 20 yrs.

KINDER, Jimmie B., (LTC) (M58) 94-465 Kauhuli Street, Waipahu, HI 96797. Dy: (808) 624-9881. Res: (808) 671-4239. S: Joanne. Job: Mil Coordinator, Hawaii Pacific Coll, Honolulu. Svc: USA. Ret: 81. 29 yrs.

KING, Clifford C., (CW4) (M69) (Cliff) 3249 E. Elery Avenue, Fresno, CA 93710. Res: (209) 299-6277. S: Diana. Svc: USA. Ret: 81. 24 yrs.

KING, David B. II., (COL) (M58) (D.B.) P.O. Box 100, Mailand, MD 64466. Res: (816) 935-2234. S: Eleanor. Svc: USA. Ret: 78. 35 yrs.

KING, Lewis O., (CW4) (M86) 8407 Greenflint Lane, Austin, TX 78759. Dy: (512) 454-7300. Res: (512) 346-0674. S: Rat. Job: Exec Dir, Nat'l Guard Assoc of Tx. Svc: USA. Ret: 87. 40 yrs.

KINLEY, Gordon L., (LTC) (M58) (Gordy) 7227 Glenfiora Avenue, San Diego, CA 92119. Dy: (619) 698-2795. Res: (714) 698-1374. S: Nancy. Job: Pres/Owner, GNK Property Mgmt Co. Svc: USA. Ret: 68. 28 yrs. Past Pres, Pikes Peak Chapter.

KINHARD, Harry W.D., (LTG) (M63) (Harry) 705 South 31st Street, Arlington, VA 22202. Dy: (703) 548-7960. Res: (703) 548-7960. S: Lobby. Job: Consultant, UTC/Williams Int'l/Burdeshaw Assoc, Schweitzer Etc. Ret: 69. 30 yrs. NEB. HOF.

KINNEY, Arthur K. Jr., (MAJ) (M57) (Art) 376 High School Drive, Lewisville, TX 75057. Dy: (214) 221-2755. Res: (214) 436-1889. S: Della. Job: Letter Carrier, US Postal Svc. Ret: 70. 20 yrs.

KIRBY, Kenneth C., (MAJ) (M59) (K.C.) P.O. Box 305, Andover, NJ 07821. Dy: (201) 383-1990. Res: (201) 788-5497. S: Ada. Job: Realtor, Lewis & Harinc, Inc. Svc: USA, USAF. Ret: 63. 21 yrs.

KIRKLIGHTER, Gerald W., (COL) (M58) (Girk) 13626 Allison Drive, Baldwin, MD 21013. Dy: (301) 584-5043. Res: (301) 592-2504. S: Ronnie. Job: ILS, Mgr, Aerospace Div, ILS Westinghouse Elec Corp. Svc: USA. Ret: 80.

K The SPOOF Roster

29 yrs.

KISLING, Richard D., (COL) (M57) (Dick) 6601 Pharoah, Corpus Christi, TX 78412. Dy: (512) 880-3404. Res: (512) 993-0502. S: Gerry. Job: Command Oic Mgr, Public Utilities. Svc: USA. Ret: 78. 32 yrs. Past Pres, Alaska Chapter.

KLEIN, Frank J., Jr., (COL) (M59) 2140 Broken Circle Road, Colorado Springs, CO 80915. Dy: (719) 550-1178. Res: (719) 550-0169. S: Marjorie. Job: Sr Scientist, Science & Tech Corp. Svc: USA. Ret: 87. 29 yrs.

KLEIN, Frank S., (LTC) (M60) 165 North Portage Path, Akron, OH 44303. Dy: (216) 762-3101. Res: (216) 867-3093. S: Patricia. Job: Pres, The Bookseller, Inc. Svc: USA. Ret: 70. 22 yrs.

KLIM, William, Jr., (LTC) (M57) (Bill) 7266 Laurie Drive, Fort Worth, TX 76112. Dy: (817) 280-2145. Res: (817) 496-3765. S: Anne. Job: Mgr, Mil Tng, Bell Hcpr. Svc: USA. Ret: 69. 21 yrs. Past Pres.

KLINE, Gerald L., (COL) (M59) (Jerry) Star Rt, Box 7A, FM 969, Bastrop, TX 78602. Res: (512) 321-6949. S: Polly. Job: Agricultural Engr. Svc: USA. Ret: 82. 31 yrs.

KLOSE, John A.G., (COL) (M63) 7067 Bridgeport Circle, Stockton, CA 95207. Dy: (209) 944-4721. Res: (209) 957-7233. S: Doris. Job: Public Info Officer, Stockton SD District. Ret: 85. 31 yrs. Past VP, Air Assault Chapter.

KNIGHT, Dan, B., Jr., (COL) (M58) (Burny) 1015 Tech Drive, Lynn Haven, FL 32444. Dy: (904) 234-4552. Res: (904) 265-3840. S: Nancy. Job: Naval Coastal Sys Cen, Panama City. Ret: 79. 27 yrs.

KNIGHT, Emmott F., (COL) (M58) 112 Francis Jessup, Williamsburg, VA 23185. Dy: (804) 838-2176. Res: (804) 253-2648. S: Margie. Job: Dist Rep, Boeing Hcpr Co. Svc: USA. Ret: 83. 30 yrs. VP, Colonial Virginia Chapter, Past Trea, Coastal Empire Chapter, 1962 AA of Year.

KNOPS, Norman, (MAJ) (M64) (Norm) 7500 Timber Ridge Court, Fort Worth, TX 76179. Dy: (817) 624-5006. Res: (817) 236-7294. S: Irene. Job: FAA. Svc: USA. Ret: 77. 20 yrs.

KNUDSLIEH, Martin G., (CW4) (M57) (Marty) 8803 Sylvania Street, Lorton, VA 22079-1612. Res: (703) 339-5136. S: Ruth. Job: Eastern Reg Mgr, Oasis Petroleum Corp. Svc: USA. Ret: 78. 30 yrs.

KOBES, Eugene H., (LTC) (M67) (Gene) Box 324-A, Colesville Rd, Binghamton, NY 13904. Dy: (607) 721-4123. Res: (607) 693-3125. S: Monique. Job: Staff Scientist, Link Fit Sim Corp. Manprint Mgr. Svc: USA. Ret: 85. 20 yrs. Trea, Edwin A Link Memorial Chap. Past VP, Bonn Area Chapter.

KOEHLER, Joseph R., (COL) (M63) (Black) 3052 Circle Road, Enterprise, AL 36530. Dy: (205) 393-3355. Res: (205) 393-4054. S: Margo. Job: Owner, The Bahnhof Hobby Shop, Dir Sity, Dyncorp. Svc: USA. Ret: 84. 31 yrs. Past Pres, Army Avn Center Chapter.

KOEHLER, William F., (COL) (M70) (Bill) 809 9th Street, Jacksonville, AL 36265. Dy: (205) 231-5781. Res: (205) 435-4047. S: Bonnie. Job: Mktg Instructor, Jacksonville State Univ. Svc: USA. Ret: 82. 29 yrs. Past Sr VP.

KOEPP, Robert W., (LTC) (M57) (Bob) 18 Ponderosa Drive, Hampton, VA 23666. Dy: (804) 766-3019. Res: (804) 766-3530. Job: Owner, Bob Koepf Assoc, Ad Agcy. Svc: USA. Ret: 68. 22 yrs.

KONOPNICKI, Emil L., (MG) (M80) Boeing Mill Airplanes, 1700 N Moore Street, Arlington, VA 22209. Dy: (703) 559-9630. Res: (703) 734-9030. S: Betty. Job: Boeing Mill Airplanes. Svc: USA. Ret: 83. 38 yrs.

KOSLOW, Norman, (MR.) (M60) 2207 Graystone Drive, St. Charles, MO 63303. S: Lucille. Svc: USA.

KOVACICH, George J., (LTC) (M67) 10545 Stephenson Drive, St Louis, MO 63128. Dy: (314) 843-0698. Res: (314) 843-0698. Job: Garrett Turbine Engine Co. Svc: USAF.

KRACHT, Peter M., (LTC) (M57) (Pete) 2040 Marsala Circle, Monterey, CA 93940. Dy: (408) 375-3500. Res: (408) 373-6680. S: Jean. Job: President, Silver Star Motors, Inc. Svc: USA. Ret: 74. 22 yrs.

KRUEGER, Walter W., (CSM) (M73) 131 Shalimar, San Antonio, TX 78213. Dy: (512) 653-6192. Res: (512) 344-8571. S: Betty Ann. Job: Pres, NCOA. Svc: USA. Ret: 83. 33 yrs. Past VP, Phantom Corps Chapter.

KUHNS, Albert W., (CW4) (M83) (Bill) 14430 Skybird Road, Chesterfield, VA 23832. Dy: (804) 452-1100. Res: (804) 796-5110. S: Gloria. Job: Sr Trng Svc, Int'l Bus. Svcs. Svc: USA. Ret: 86. 25 yrs.

KUHSTEL, Kenny J., (LTC) (M88) (Ken) Rockwell Int'l, 1745 Jeff Davis Hwy-1200, Arlington, VA 22202. Dy: (703) 553-6885. Res: (703) 323-1891. S: Carol. Job: Washington Rep, Rockwell Int'l Corp. Svc: USA. Ret: 88. 20 yrs.

KUSILKA, Anthony G., (CW4) (M86) (Jerry) 1532 Dover Ct, Fayetteville, NC 28304. Dy: (919) 396-4577. Res: (919) 485-4762. S: Geraldine. Job: Fit Sim Inst, Fort Bragg. Ret: 78. 30 yrs.

KUYKENDALL, William K., (COL) (M61) (Ken) 18 Lake Lorraine Circle, Shalimar, FL 32579. Dy: (904) 651-2878. S: Judy. Ret: 83. 27 yrs.

KUYPERS, Tom O., (LTC) (M81) 1005 Jefferson Street, St. Charles, MO 63301. Dy: (314) 232-5992. Res: (314) 947-1617. S: Patricia. Job: Sec Mgr, F/A-18 PGM, McDonnell Acrtf. Svc: USA. Ret: 84. 23 yrs.

LI

LALICKER, Laurence, (LTC) (M74) (Gene) 537 Covered Bridge Road, Cherry Hill, NJ 08034. Dy: (215) 591-2916. Res: (609) 354-6147. S: Betty. Job: Mgr Military Ops Boring Hcpr. Svc: USA. Ret: 86. 20 yrs.

LAMA, John A., (MAJ) (M67) 8715 S. Kingston Avenue, Chicago, IL 60617-2442. Res: (312) 221-6158. Svc: USA. Ret: 86. 20 yrs. Past Sec, Aloha Chapter.

LAMAR, Richard E., (CW4) (M79) Hawthorne Aviation, P.O. Box 10035, Charleston, SC 29411. Dy: (803) 284-2039. Res: (803) 284-2575. S: Edeltraud. Job: Pres, Graystone Consultants, Inc. Svc: USA. Ret: 74. 25 yrs.

LA MONICA, Rich S., Sr., (CW4) (M72) (Dick) 16521 89th Ave E, Puyallup, WA 98373. Dy: (206) 952-5000. Res: (206) 845-1351. Job: Surety Mgr, Reliance, United Pacific. Svc: USA. Ret: 83. 26 yrs.

LAMONTE, Robert S., (LTC) (M62) (Bob) 912 Fritz Court, Copperas Cove, TX 76522. Dy: (817) 288-9097. Res: (817) 547-3474. S: Jackie. Job: Mgmt Analyst, Force Mgmt, CSRM, Texcom. Svc: USA, USN. Ret: 76. 26 yrs. Past Sec, Phantom Corps Chapter.

LANDRY, Edward L., (COL) (M61) (Ed) 6601 Seward Lane, Bowie, MD 20715. Dy: (703) 521-9356. Res: (301) 262-2425. S: Ann. Job: VP, Logistics Co, Nat'l Sys Mgmt, Arlington. Svc: USA. Ret: 73. 26 yrs. Past Sec, Arizona Chapter.

LANDRY, Robert L., (LTC) (M85) (Bob) 3304 Somerset Drive, Arlington, TX 76013. Dy: (817) 625-8855. Res: (817) 274-2255. S: Mildred. Job: Instru Aero Tech, Ft. Worth; Tarrant City Jr Coll. Svc: USA. Ret: 73. 22 yrs.

LANG, William F. Jr., (COL) (M60) (Bill) 1909 North Cherokee Ave., Dothan, AL 36303. Res: (205) 793-2078. S: Frieda. Svc: USA. Ret: 79. 35 yrs. Past Sr VP, Hanau Chapter.

LANGLOIS, Arthur R., (LTC) (M61) (Art) 869 Frouder Avenue, New Smyrna Beach, FL 32069. Res: (904) 423-9278. S: Jiravan. Svc: USA. Ret: 70. 25 yrs. Past VP, Southern California Chapter.

LAPOSKY, Robert E., (LTC) (M79) (Bob) 4650 W Florissant Ave., St. Louis, MO 63115. Dy: (314) 381-0038. Res: (314) 723-5647. S: Dee. Job: Aerospace Associates. Svc: USA. Ret: 84. 20 yrs. Past VP, Lindbergh Chapter.

LARCOMB, David J., (LTC) (M64) 1183 Leicester Place, Worthington, OH 43085-2181. Res: (614) 436-9089. S: Ruth. Job: Ohio St. Comp Store Mgr. Svc: USA. Ret: 87. 28 yrs. Past Treas, Golden Gate Chapter.

LARGE, Ulysses S., Jr., (COL) (M57) (U.Sugar) 436 Village Drive, Daphne, AL 36526. Dy: (205) 626-3181. Res: (205) 626-9722. S: Peggy. Job: Associates Realty. Ret: 77. 23 yrs. Past VP, Lindbergh Chapter.

LAUDER, Ralph H., (COL) (M68) (Ralph) Lauder & Associates, Inc, 13035 Olive St Rd, Ste 119, St. Louis, MO 63141. Dy: (314) 578-9235. Res: (314) 863-6351. S: Anne. Job: Pres, Lauder & Assoc. Svc: USA. Ret: 86. 24 yrs.

LAUER, Jerry B., (MG) (M71) (Jerry) 9024 Crichton Woods Drive, Orlando, FL 32819. Res: (407) 876-3796. S: Anne. Svc: USA. Ret: 77. 31 yrs.

LAUMAYER, Norman G., (LTC) (M57) 21 Hall Street, Daleville, AL 36322. Dy: (205) 255-5516. Res: (205) 598-4813. S: Barbara. Job: Tng Spec, Avn, Civil Svc, Ft. Rucker. Svc: USA. Ret: 70. 24 yrs.

LAUTERBACH, John W., (COL) (M59) 2107 Stirrup Lane, Alexandria, VA 22306. Res: (703) 780-8713. S: Nikki. Svc: USA. Ret: 76. 30 yrs.

LAVERY, Harry L., (LTC) (M88) 2823 S. Joyce St., Ste 1, Arlington, VA 22202. Dy: (202) 882-0073. Res: (703) 548-8415. S: Kay. Job: Dir, Recoupment Determinations, Navy Off/Tech Transfer & Sec Assist. Svc: USAF. Ret: 80. 22 yrs.

LAYA, Robert E., (LTC) (M59) (Bob) 337 Palmetto Drive, Corpus Christi, TX 78412. Dy: (512) 992-5661. Res: (512) 991-5450. S: Sally. Job: Reg Rep & Agent, USPA & IRA. Svc: USA. Ret: 76. 20 yrs. Past Pres, Mainz Chapter.

LAYFIELD, Marvin C., (LTC) (M70) (Monk) 69 Morrow Drive, Bedford, TX 76021. Dy: (817)

The SPOOF Roster

355-5521. Res: (817) 283-6539. S: Tangye. Job: Instructor, Amer Airlines. Ret: 79. 27 yrs.

LAYNE, Leslie A., (COL) (M60) (Burr) 2106 Azalea, Killeen, TX 76541. Res: (817) 526-4634. S: Tibby. Svc: USA. Ret: 82. 31 yrs. Past Sr VP.

LAZZELL, Rufus C., (BG) (M71) 1600 Montic Court, Punta Gorda Isles, FL 33950. Res: (813) 637-7467. S: Jo Jac. Job: Councilman, City of Punta Gorda. Ret: 81. 30 yrs. Past Pres.

LEACH, Bertram G., (LTC) (M60) (Bert) 2202 Sherwood Court, Minnetonka, MN 55343. Dy: (612) 338-9000. Res: (612) 593-0821. S: Norma. Job: Municipal & Gov't Bond Broker, M.H. Novick. Ret: 72. 20 yrs.

LEACH, Ernie J., (COL) (M60) 310 Shaftesbury Lane, Summerville, SC 29485. Dy: (803) 572-6303. Res: (803) 875-3224. S: Dorrine. Job: Business Broker, Martin Thompson & Wilkinson. Svc: USA. Ret: 84. 31 yrs.

LEGENER, Richard G., (COL) (M58) (Dick) 2800 Manassas Court, College Station, TX 77840. Res: (409) 696-2404. S: Mariann. Svc: USA. Ret: 77. 26 yrs.

LEHARES, Constantine, (MR) (M66) (Dino) 221 East O'Fallon, Caseyville, IL 62232. Res: (618) 344-7481. S: Barbara. Svc: USA.

LEHMAN, Raymond G Jr., (COL) (M59) (Dutch) 205 Soledad Drive, Monterey, CA 93940. Res: (408) 375-1347. S: Alida. Svc: USA. Ret: 74. 32 yrs.

LEHNER, Charles R., (COL) (M62) (Charlie) 14 Valleywood Court, Timonium, MD 21093. Dy: (301) 628-3423. Res: (301) 252-2419. Job: Dir, CBT Electric Dev, AAI Corp. Ret: 71. 26 yrs. Past Sec, Washington DC Chapter.

LEHRYER, John B., (LTC) (M75) 550 Highland Circle, Florence, AL 35630. Res: (618) 234-9856. S: Barbara. Job: Airport Mgr, Muscle Shoals Airport. Svc: USA. Ret: 87. 23 yrs.

LEINS, David V., Jr., (LTC) (M60) (Dave) TPC Logistics Serv., Inc, 644 Ridgefield Court, Glen Burnie, MD 21061. Dy: (301) 964-6732. Res: (301) 760-7315. S: Carole. Job: Pgm Mgr, B-18 Slate Maint Trng Sys, Daedalus, Inc. Svc: USA. Ret: 84. 28 yrs.

LEISTER, Glenn A., (LTC) (M57) 9702 Rumbling Ridge Ct, Fairfax Station, VA 22039. Dy: (703) 683-4646. Res: (703) 440-8151. S: Sue. Job: Dir, Shty & Fit Opns, Hcpr Assoc., Int'l. Svc: USA. Ret: 82. 26 yrs.

LEISTER, Richard W., (LTC) (M60) (Dick) 5821 Antigua Boulevard, San Diego, CA 92124. Dy: (619) 573-5164. Res: (619) 565-9824. S: Jean. Job: Mgr Computer Mtdg, Gen Dynamics Elec. Svc: USA. Ret: 77. 24 yrs.

LEMING, Joe A., (MAJ) (M63) 377 De Shazer Drive, Newport News, VA 23602. Dy: (804) 878-6875. Res: (804) 874-0767. S: Ann. Job: Logistics Mgmt Spec DAC, DCD, USAALS, Ft. Eustis. Svc: USA. Ret: 79. 22 yrs.

LENCI, Joseph V., (LTC) (M61) (Joe) 614 Priest Ford Road, Churchville, MD 21028. Dy: (301) 584-1477. Res: (301) 836-2868. S: Jeanette. Job: Test Eng, Integral Technologies Inc. Ret: 80. 23 yrs. Past Pres, Pikes Peak Chapter.

LEONARD, Daniel R., (COL) (M63) (Dan) 321 Scott Drive, Silver Spring, MD 20904-1063. Dy: (703) 941-9021. S: Faye. Job: Snr Industrial Spec, Nat'l Sys Mgmt Corp. Svc: USA. Ret: 84. 25 yrs.

LEONARD, Jesse W., (CW4) (M60) 613 N. 67th Place, Mesa, AZ 85205. Dy: (602) 891-3725. Res: (602) 981-0788. S: Jean. Job: Flight Test Engr, McDonnell Douglas Hcpr Co. Svc: USA. Ret: 78. 26 yrs.

LEONARD, John F. Jr., (CW4) (M65) 3016 Dove Drive, Sierra Vista, AZ 85635. Res: (602) 458-2588. S: Mary. Ret: 77. 29 yrs. Past Pres, Old Tucson.

LEONARD, William B., (LTC) (M73) (Bud) 4932 Springbrook Dr, Annandale, VA 22003. Dy: (703) 821-8896. Res: (703) 978-0695. S: Jandra. Job: Administrator, McLean Presbyterian Church. Ret: 85. 20 yrs.

LESTER, Rodney D., (LTC) (M75) (Rod) 1106 Mook Street, Brandon, FL 33511. Dy: (407) 380-2423. Res: (813) 684-3733. S: Joann. Job: Pgm Mgr, Simms Industries, Inc. Ret: 81. 24 yrs.

LEUPPERT, Fred W., (LTC) (M58) Rt 1, Box 88, Blumenton, VA 22012. Dy: (703) 883-6810. Res: (703) 360-5741. S: Marilyn. Job: Tech Staff, The Mite Corp, McLean. Svc: USA. Ret: 75. 23 yrs.

LEUTY, Ray S., (LTC) (M74) 5316 Musket Ridge Parkway, Austin, TX 78759. Dy: (512) 346-3111. Res: (512) 346-1540. S: Marilyn. Job: Owner, Exec Printing Cir. Svc: USA. Ret: 80. 20 yrs.

LEVINSON, Joseph, (COL) (M58) (Joe) F67677, P.O. Box 44209, Cincinnati, OH 45244. Dy: (800) 445-1732. S: Carolyn. Job: Pres., U.S. Computer Corp. Svc: USA, USN. Ret: 67. 22 yrs.

LEWIS, Charles, (SFC) (M77) (Lew) 2357 Carpenter Road, Wilmington, DE 19810. Dy: (215) 522-7945. Res: (302) 475-3568. Job: Spvr Flight Test, Boeing Hcprts. Svc: USA. Ret: 85. 20 yrs.

LEWIS, Donald J., (LTC) (M58) (Don) 3515 Jubilee Trail, Dallas, TX 75229. Dy: (214) 352-1970. Res: (214) 352-1970. S: Diane. Job: Owner/Opn, Don Lewis Real Estate. Ret: 69. 26 yrs.

LEY, Donald R., (COL) (M63) (Don) 3625 Camelot Drive, Annandale, VA 22003. Dy: (703) 698-1772. S: Pat. Svc: USA. Ret: 87. 30 yrs.

LILLEY, Aaron L. Jr., (MG) (M60) 6583 Zoysia Court, Alexandria, VA 22312-3135. Dy: (703) 979-2500. Res: (703) 354-3869. S: Betty. Job: Dir Systems Planning, Karman Aerospace Corp. Svc: USA. Ret: 85. 33 yrs. Past VP, Sully Chapter.

LILLY, Grady F., (COL) (M59) 2948 Hillcreek Circle S., Clearwater, FL 34619. Res: (813) 797-7570. S: Irene. Svc: USA. Ret: 67. 29 yrs.

LITTLE, Robert F. Jr., (COL) (M57) (Bob) 614 Ash Street, Copperas Cove, TX 76522. Dy: (817) 547-6537. Res: (817) 547-4947. S: Linda. Job: Exec Dir, 1st Cav Assoc. Svc: USA, USAF. Ret: 73. 30 yrs. Past Sr VP, HOF.

LOCKEY, Claude B., (MR) (M66) (Cb) 2100 Muse Street, Fort Worth, TX 76112. Res: (817) 451-8197. S: Romona. Job: Field Svc Tech Rep, Bell Hcpr Textron.

LOCKWOOD, Bill G., (COL) (M59) (Bill) 102

Linda Drive, Enterprise, AL 36330. Res: (205) 393-2416. S: Annemarie. Svc: USA. Ret: 84. 31 yrs.

LOFTIN, Thomas W., (LTC) (M57) (Duck) 444 Channing, San Antonio, TX 78210. Res: (512) 532-9400. S: Imogene. Job: Conductor, Southern Pacific Railroad. Svc: USA, USAF. Ret: 72. 28 yrs.

LONG, Billy J., (CW3) (M59) (B.J.) 2601 Rose Valley Drive, Fort Washington, MD 20744. Dy: (301) 952-8252. Res: (301) 248-6842. S: Joan. Job: Manager, System Design & Prog. Prince George's Public School. Ret: 68. 20 yrs.

LONG, Donald E., (LTC) (M63) (Don) Hqs. VII Corps, P.O. Box 1312, APO NY 09107. Dy: 011-729-2553. Res: 011-457-0804. S: Marit. Job: Safety Spec, VII Corps. Svc: USA. Ret: 80. 20 yrs.

LORENZ, Dwight L., (LTC) (M59) (Dwight) P.O. Box 270, Bennington, VT 05201. Dy: (802) 442-3280. Res: (802) 442-3280. S: Helke. Job: Dir, Dwight L. Lorenz & Assoc. Svc: USA. Ret: 70. 20 yrs. Past VP, Tauhus Chapter.

LOVE, John A., (COL) (M58) 27 Poplar, Shalimar, FL 32579. Dy: (904) 243-6180. Res: (904) 651-5854. S: Virginia. Job: Vice President/Broker, Harry G. Howton Realty. Svc: USA. Ret: 76. 31 yrs.

LOWE, Thomas R. Jr., (MAJ) (M70) (Jerry) 102 Snelbridge Road, Daleville, AL 36322. Dy: (205) 598-2500. S: Merline. Svc: USAF. Ret: 61. 21 yrs.

LOWERY, Roy J., (MAJ) (M63) 139 N. Mt. Vernon Avenue, Loudonville, OH 44842. Dy: (419) 994-4181. Res: (419) 994-5147. S: Nancy. Job: Plant Manager, Conagra, Inc. Svc: USA. Ret: 61. 20 yrs.

LUCE, Donald F., (LTC) (M57) (Don) 603 Flemington Road S.E., Huntsville, AL 35802. Dy: (205) 881-2332. Res: (205) 882-3039. S: Ruth. Job: Consultant. Ret: 69. 22 yrs. Past NEB. Sr VP, Tennessee Valley Chapter. Past Pres, Lindbergh Chapter.

LUKERT, Edward P. Jr., (COL) (M57) (Ed) 3620 Lake Pontchartrain, Arlington, TX 76016. Dy: (817) 551-4181. Res: (817) 478-8679. S: Carol. Job: Mgr of Pub. Adv & PR, Gearhart Ind. Svc: USA. Ret: 78. 28 yrs. Past Pres, Lone Star Chapter.

LUM, David A., (LTC) (M69) 2640 Purdue Drive, Vestal, NY 13850. Dy: (607) 751-4369. Res: (607) 770-7023. S: Patricia. Job: IBM, Advisory System Engineer. Svc: USA. Ret: 88. 22 yrs.

LUPTON, Wm. R., Jr., (LTC) (M59) (Bill) 3037 Kingspoint Avenue, Las Vegas, NV 89120. Dy: (702) 295-0664. Res: (702) 458-8200. S: Jackie. Job: Sr. Admin. Staff Asst.. Svc: USA. Ret: 68. 22 yrs.

LUTZ, George A., (COL) (M59) 3433 Cullen Lake Shore Dr, Orlando, FL 32812. Res: (305) 859-0334. S: Evelyn. Svc: USA. Ret: 71. 33 yrs.

LYBRAND, James E., (LTC) (M87) (Jim) 6601 Beaver Tr, Midland, GA 31820. Dy: (404) 563-1264. S: Betty. Svc: USA. Ret: 77. 24 yrs.

LYONS, Sidney E., (LTC) (M84) 30 Montauk Drive, St. Louis, MO 63146. Dy: (314) 263-1831. Res: (314) 432-5838. S: Phyllis. Job: Logistics Mgmt Spec. USA AVSCOM. Svc: USA. Ret: 80. 20 yrs.

MMMMMMMMMM

MACKELL, Bernard B., (MAJ) (M58) (Bernie) 10321 Kingbrook Lane, Orlando, FL 32821. Res:

M The SPOF Roster

(407) 351-4109. S: Margaret. Svc: USA. Ret: 81. 37 yrs.

MACKIN, Richard E., (COL) (M58) (Dick) 37 Sandpiper Court, Hampton, VA 23669. Dy: (804) 865-2655. Res: (804) 850-0461. S: Sue. Job: Dir, NASSA, Jt. Association, Inc. Svc: USA. Ret: 84. 28 yrs.

MACKMULL, Jack V., (LTC) (M58) (Mack) 1190 Plantation Lane, Mt. Pleasant, SC 29464. Dy: (803) 881-1382. Res: (803) 881-1382. S: Beverly. Job: Pres, Mackmull Assoc. Consultants. Svc: USA. Ret: 84. 34 yrs.

MADDEN, Michael J., (CW4) (M58) (Mike) 414 W. Hildreth Street, Enterprise, AL 36330. Dy: (205) 255-3880. Res: (205) 347-8357. S: Nicole. Job: Woodworking Instructor, Fort Rucker, AL. Ret: 74. 23 yrs. 80 AA of Yr.

MADDOX, Wm. J., Jr., (MG) (M57) (Bill) 50 Loyang Way, Singapore 1750. Dy: (065) 542-2422. Res: (065) 466-2714. S: Jaye. Job: Managing Dir, Rel Hqtr, Asia. Svc: USA. Ret: 76. 34 yrs. Past NEB. HOF.

MADIGAN, John E., (LTC) (M63) (Mad Jack) P.O. Box 00, Friendswood, TX 77546. Res: (713) 996-1709. Svc: USA. Ret: 80. 21 yrs.

MADISH, Daniel T., (COL) (M65) (Dan) 12029 Lake Newport Road, Herndon, VA 22070. Dy: (703) 761-3200. Res: (703) 481-1240. S: Elisabeth. Job: Advanced Technical Systems, Director of Business Dev. Svc: USA. Ret: 84. 22 yrs. Past Pres.

MAHONE, Nelson A. Jr., (COL) (M57) (Mike) 226 Woodlawn Drive, Panama City, FL 32407. Dy: (904) 234-3221. Res: (904) 234-3221. S: Maxine. Svc: USA. Ret: 74. 31 yrs. Past Pres, Aloha Chapter.

MAHONEY, Worthington, (COL) (M57) (Wort) P.O. Box 22737, Carmel, CA 93922. Res: (408) 625-9456. S: Mina. Svc: USA. Ret: 74. 31 yrs.

MAKUCH, Walter S., (LTC) (M58) (Mak) P.O. Box 1593, Choctaw, OK 73020-1593. Res: (405) 769-3668. S: Lorraine. Svc: USA. Ret: 67. 32 yrs.

MALMSTEN, Lee R., (MR) (M78) (Mr. Lee) 300-B E. Brunson Street, P.O. Box 324, Enterprise, AL 36331. Res: (205) 347-1421. Job: Self-employed, Aerospace Research. Svc: USA. Ret: 79.

MANGUM, Robert A., (COL) (M59) (Bob) 100 Burwell Court, Williamsburg, VA 23185-5516. Dy: (804) 827-1500. Res: (804) 253-5798. S: Cary. Job: Tidewater Mgr, McDonnell Douglas Helicopt Co. Svc: USA. Ret: 84. 25 yrs. Past Treas, Tauhus Chapter.

MANTOOTH, Glen W., (CW4) (M78) 4166 Edenville Road, Chambersburg, PA 17201. Dy: (717) 267-8084. Res: (717) 264-6675. S: Charlotte. Job: Dir Dual Assurance, Letterkenny Army Depot. Svc: USA. Ret: 75. 27 yrs.

MAPP, James H., (BG) (M59) (Jim) Circle M Ranch, Route 1, Box 180, Coppens Cove, TX 76522. Res: (817) 547-6239. S: Ann. Job: Cattle Rancher/Owner Circle M Ranch, Regional Aircraft Appraiser, World Wide Aircraft Appraisers, Inc. Svc: USA. Ret: 80. 31 yrs.

MARDONEY, George E., (LTC) (M61) P.O. Box 377, Lake Orion, MI 48035-0377. Dy: (313) 663-8311. Res: (313) 391-0919. S: Vivian. Job: VP

Engr, MC Aerospace. Svc: USA. Ret: 88. 32 yrs.

MARR, John W., (COL) (M60) 1618 South 22D Street, Arlington, VA 22202. Dy: (703) 521-7678. Res: (703) 521-7678. S: Willa. Svc: USA. Ret: 74. 32 yrs. NEB. Past Pres, Washington DC Chapter.

MARSHALL, Norris T., (CW3) (M71) Route 2, Box 20A, Chapman, KS 67431. Dy: (913) 776-0511. Res: (913) 922-6598. S: Eloise. Job: Special Agent, OOD, Manhattan, KS. Svc: USA. Ret: 78. 20 yrs.

MARTIN, George E., (LTC) (M65) 440 Cabrillo Avenue, Davis, CA 95616. Res: (916) 756-2830. S: Linda. Job: Cien Donald-CA St. Millsa. Svc: USA. Ret: 68. 25 yrs. Past Pres.

MARTIN, John J., (LTC) (M64) 1709 Montana Vista, Lake Havasu City, AZ 86403. Res: (602) 453-6476. S: Aijoe. Svc: USA. Ret: 61. 21 yrs.

MASON, Kenneth A., (LTC) (M70) (Ken) 61 Forest Avenue, West Babylon, NY 11704. Res: (516) 587-0280. S: Lorraine. Ret: 65. 38 yrs.

MASON, Willie Oran, (CW3) (M75) (Patsy) 11022 Rockledge, El Paso, TX 79934. Dy: (915) 821-6476. Res: (915) 821-6476. S: Vicki. Job: Bass Fisherman, Ranger Bouts, Pippin, AK. Svc: USA. Ret: 78. 20 yrs.

MATHEWS, William R., (COL) (M57) (Randy) 9202 Windview Drive, San Antonio, TX 78238. Dy: (512) 653-1122. Res: (512) 653-1122. S: Janice. Job: Real Estate Broker, Randy Mathews Realtors. Svc: USA. Ret: 72. 34 yrs. Past Pres.

MATHISON, Theodore E., (COL) (M58) (Ted) 322 Lazywood Court, Millersville, MD 21108. Dy: (301) 859-7060. Res: (301) 887-9591. S: Ellen. Job: Administrator, State Avn Admin, Baltimore/Washington Int'l Airport. Svc: USA. Ret: 78. 23 yrs.

MATSON, Donald F. Jr., (LTC) (M72) (Rick) 8 Saddle Hill Road, Monroe, CT 06468. Dy: (203) 388-4071. Res: (203) 268-8036. S: Rosemary. Job: Prog Mgr, SH-60F, Sikorsky Acrift. Svc: USA. Ret: 83. 21 yrs.

MATTHEWS, Ralph A., (COL) (M58) (Matt) Legal Center, 8120 Richmond Hwy., Alexandria, VA 22309. Dy: (703) 780-7202. Res: (703) 442-0298. S: Nell. Job: Attorney, Tate & Wyacker Ltd. Ret: 64. 35 yrs. Past Treas.

MATTSO, Bernard H., (LTC) (M62) (Matt) 31 Parkview Drive, East Hartford, CT 06108. Res: (203) 289-4272. S: Bettie. Svc: USA, USAF. Ret: 67. 20 yrs. Past VP, Connecticut Chapter.

MAUK, Gerald F., (COL) (M84) (Jerry) Boeing Company, 1700 N. Moore St, 20th Fl, Rosslyn, VA 22209. Dy: (703) 568-9614. S: Marilyn. Job: Army Rep, Boeing Aerosp. Svc: USA. Ret: 84. 29 yrs.

MAXWELL, W. George, (CW4) (M72) (George) Route 4, Box 202, Ozark, AL 36360. Dy: (205) 598-2418. Res: (205) 774-6884. S: Judy. Job: Manager, Army Sales Office - Fort Rucker Link Flight Simulation Corp. Svc: USA. Ret: 84. 24 yrs.

McANDREW, Thomas J. Jr., (LTC) (M58) (Tom) P.O. Box 6413, Mac Dill AFB, FL 33608-0413. Res: (813) 837-5549. Svc: USA. Ret: 72. 20 yrs.

McBRIDE, Maurice B., (MAJ) (M53) 15067 Meadow Oak Place, Salinas, CA 93907. Svc: USA. Ret: 78. 30 yrs.

McCARY, James G., (COL) (M62) (Mac) 302 Henderson Street, Enterprise, AL 36330. Res:

(205) 347-6169. S: Milline. Svc: USA, USAF. Ret: 76. 30 yrs.

McCHESNEY, Frank L., (LTC) (M59) 34 Jenkins Road, Franklin, NJ 07416. Dy: (201) 363-6700. Res: (201) 827-2185. S: Celia. Job: Asst Supr For Bus., Sussex Co Vo-Tech School. Svc: USA. Ret: 71. 20 yrs. Past Sr VP.

McCLINTOCK, Alfred B., (LTC) (M58) 2918 Stonybrook Drive, Bowie MD 20715. Dy: (703) 553-0200. Res: (301) 262-5611. S: Phyllis. Job: Logistics PM. Info Spectrum, Inc.. Svc: USA. Ret: 71. 20 yrs.

McCONNELL, Lewis J., (COL) (M57) (Law) 6128 E. Snowdon Street, Mesa, AZ 85205. Dy: (602) 891-2146. S: Betty. Job: McConnell Douglas Hcpr, Mgr, Military Product Support. Ret: 83. 31 yrs. NEB. Pres, Arizona Chapter. Past Pres, Southern California Chapter.

McCOOLE, Delos A., (LTC) (M59) (Art) 756 Monterey Avenue, Chula Vista, CA 92010. Dy: (619) 670-1990. Res: (619) 426-7674. S: Pat. Job: Aeronautics Coordinator, Instructor, Cuyamaca Comm Coll, El Cajon. Svc: USA. Ret: 77. 23 yrs. Past Sr VP, Monterey Bay Chapter.

McCULLOUGH, James L., (CW4) (M61) 4146 Checkmate Drive, Anchorage, AK 99508. Dy: (907) 786-8227. Res: (907) 338-0393. S: Sara. Job: Ops Supr, Publ Transit Municipality. Svc: USA. Ret: 79. 30 yrs.

McCULLOUGH, Johnny L., (MAJ) (M63) 7567 Pinewood Drive, Chattanooga, TN 37421. Dy: (404) 858-2290. Res: (615) 894-5664. S: Margaret. Job: Dir Plant Engrg, Hutcheson Med. Ctr., Oglethorpe, GA. Svc: USA. Ret: 74. 23 yrs. Past VP.

McDONALD, Fritz J., (MAJ) (M58) (Mac) P.O. Box 18598, Corpus Christi, TX 78414. Dy: (512) 939-3388. S: Gladys. Job: Aircraft Quality Assurance Supervisor, CNATRA, NAS Corpus Christi. Svc: USA. Ret: 80. 30 yrs. Past Sec. Tu-can Chapter.

McDONALD, Harold F., (LTC) (M57) (Mac) P.O. Box 48555, Cumberland, NC 28331. Dy: (919) 323-0601. Res: (919) 425-0946. S: Bonnie. Job: Habilitation Prog, Dir, Mental Health Center. Svc: USA. Ret: 70. 23 yrs.

McDONALD, James A., (LTC) (M58) (Jim) P.O. Box 472, Litchfield, IL 62556. Dy: (217) 324-5333. Res: (217) 324-5880. S: Gloria. Job: Pres., MBD Associates. Svc: USA. Ret: 72. 20 yrs. Past Pres, Tu-can Chapter.

McDOWELL, Chester W., (COL) (M57) (Chet) 3904 Sandalwood Court, Fairfax, VA 22031. Dy: (703) 750-2037. Res: (703) 978-1982. S: Mickey. Job: VP Army Programs, Nat'l Sys Mgmt Corp. Svc: USA. Ret: 79. 29 yrs. Past VP, Monmouth Chapter.

McELROY, James M., (SSG) (M76) (Sgt Mac) 7020 Parliament Drive, Tampa, FL 33619. Res: (813) 626-6967. Svc: USA. Ret: 84. 20 yrs.

McENERY, John W., (LTG) (M70) (John) 23735 Determine Lane, Monterey, CA 93940. Res: (408) 649-8621. S: Constance. Svc: USA. Ret: 83. 35 yrs.

McGAUGH, Michael, (LTC) (M63) (Mike) 2524 Fox Glenn Circle, Bedford, TX 76021. Dy: (214) 550-8000. Res: (817) 354-7211. S: Judy. Job: Dir of Army Prog, Ft Stry Int'l. Svc: USA. Ret: 87. 20 yrs.

McGEE, Bernard A., (COL) (M57) (Barney) Bell Helicopter Arabia, Box R, APO NY 09017. Dy: 011-966-2-725-2122/2118. Res: 011-2-725-

M The SPOOF Roster

4120. S: Kathy. Job: Resident Mgr, Bell Hcpr Arabia. Svc: USA. Ret: 84. 30 yrs. Past Sr VP, Suncoast Chapter.

McGEE, George P., (LTC) (M68) (Pres) Rd #3, Box 3030, Matthews Drive, Binghamton, NY 13901. Dy: (607) 721-6468. Res: (607) 648-5721. S: Dianne. Job: Mgr, Acquisition Mgt, Link Flight Sim Corp.. Svc: USA. Ret: 86. 20 yrs. Past VP, Suncoast Chapter.

McGEHEE, Arthur J., (SGM) (M79) (Mac) 11066 Dunkin Drive, Apt. 208, St. Louis, MO 63138. Dy: (314) 263-1363. Res: (314) 867-8298. S: Suzanne. Job: Logistics Mgt Spec, AVSCOM. Svc: USA. Ret: 82. 22 yrs.

McGILLICUDDY, C.F., Jr., (COL) (M59) (Neil) Vinnell Corp, Box 937, APO NY 09038. Dy: (966) 478-5565. Res: (966) 478-5565 x258. S: Betty. Job: Mgr, Military Schools, Saudi Arabia Nat'l Guard, Vinnell Corp. Svc: USA. Ret: 83. 31 yrs. Past Pres, Follow Me Chapter.

McGINNESS, Harry J., (LTC) (M72) 34 Gallant Fox Drive, Media, PA 19063. Dy: (215) 499-9513. Res: (215) 565-4578. S: Debbie. Job: Sr Mgr Logistics, Boeing Hcpr. Svc: USA. Ret: 88. 22 yrs. Past VP.

McGINN, Peter W., (COL) (M58) (Pete) 91 Marina Road, Hampton, VA 23669. Dy: (804) 722-6037. Res: (804) 722-6037. S: Lee. Job: Owner, McGurl Yacht Accommodations Co. Ret: 81. 31 yrs.

McKEEN, Chester M., (MG) (M68) (Chet) 2310 Woodson Trail, Arlington, TX 76016. Dy: (817) 280-8501. Res: (817) 654-1799. S: Virginia. Job: VP Materiel, Bell Hcpr Textron. Svc: USA. Ret: 77. 34 yrs.

McLENNAN, Stuart G. Jr., (LTC) (M57) (Stu) 16619 Fort Oswego, San Antonio, TX 78247. Dy: (512) 229-5882. Res: (512) 655-9274. S: Abbie. Job: U.S. Congress, District Director. Svc: USA. Ret: 78. 25 yrs. Past VP, Leavenworth Chapter. Charter Life Member.

McMAKEN, Edward, (COL) (M57) (Ed) 1115 Westview Drive, Ozark, AL 36360. Res: (205) 774-5433. S: Marjorie. Job: Reg Rep, George Wood & Co Inc. Svc: USA. Ret: 64. 31 yrs. Past Pres, Army Avn Center Chapter.

McMANUS, George F., Sr., (MR) (M82) 3119 Donnycave Lane, Maryland Heights, MO 63043-1367. Dy: (314) 298-7757. Res: (314) 344-9032. S: Claire Anne. Job: Pres, COB, Geo F. McManus Enterprises, Inc.. Svc: USA. Ret: 76. 4 yrs.

McMILLON, Don, (LTC) (M59) Box 262, Weatherford, OK 73096. Dy: (405) 772-6143. Res: (405) 772-6574. S: Teddy. Job: Pres & GM, McMillon Avn, Inc. Svc: USA. Ret: 76. 23 yrs. Past Sec, Mainz Chapter.

McMILLAN, Donald J. Jr., (MAJ) (M64) (Scotty) 761 Alvarado Drive, Salinas, CA 93907. Dy: (408) 242-2376. Res: (408) 422-3936. Job: Instrument Fit Inst Shts, Hq, FritzscheAAF, Ft. Ord. Svc: USA. Ret: 78. 21 yrs. Past VP, Schwaebisch Hall Chapter.

McNAIR, Carl H., Jr., (MG) (M58) 7821 Friars Court, Alexandria, VA 22306. Dy: (703) 229-5800. Res: (703) 660-9753. S: Jo Ann. Job: Burdeshaw Associates Ltd, Wash DC, VP Army Programs. Svc: USA. Ret: 87. 32 yrs. Past NEB. Past Sr VP, Washington DC Chapter.

McNAIR, Jephth J. Jr., (LTC) (M59) (J.I.) 3632 Nassau Drive, Augusta, GA 30909. Dy: (404) 738-6641. Res: (404) 738-6428. S: Margret. Job: Realtor, Sherman & Hamstreet. Svc: USA. Ret: 78. 24 yrs.

McPhail, Billy B., (MAJ) (M57) 1308 Pine Drive, Killeen, TX 76543. Dy: (817) 287-2846. Res: (817) 634-0752. S: Ruth. Job: Suprv, Equip Spec (Aircraft) Maint. Div. DOL, Ft. Hood, APACHE Proj Ofcr. Svc: USA. Ret: 60. 23 yrs.

McWILLIAMS, Bayard T., (MR) (M60) (Bob) Mac 1300 University Drive, Yardley, PA 19067. Dy: (609) 396-8216. Res: (215) 493-5426. S: Lillian. Job: Pres, McWilliams Engrg. Inc.. Svc: USA. 17 yrs.

MEADE, Robert W., (CW4) (M63) 15 Pine Way Drive, Daleville, AL 36322. Dy: (205) 596-6342. Res: (205) 596-6548. S: Lou. Job: Asst Dir, FSI.. Ret: 75. 24 yrs. Past Pres, Mainz Chapter.

MEADER, Jerome C. Jr., (LTC) (M59) (Jerry) P.O. Box 3116, Cornwall, NY 12518. Dy: (914) 462-6100. Res: (914) 534-7619. S: Elma. Job: Cpt, Command Airways, Inc. Svc: USA. Ret: 72. 20 yrs.

MEISSNER, Kenith E., (LTC) (M65) (Ken) 2704 North Kensington St, Arlington, VA 22207. Dy: (202) 646-2196. Res: (703) 533-2133. S: Rachel. Job: Principal Engr., ARINC. Svc: USA. Ret: 80. 22 yrs. Past VP, Monmouth Chapter.

MELLISH, James R., (LTC) (M57) (Jim) 200 Windcreek Way, Enterprise, AL 36330. Res: (205) 393-3766. S: Jeannette. Job: Field Rep, U.S. Life Ins. Corp.. Svc: USA. Ret: 82. 28 yrs.

MELROD, John L., Jr., (LTC) (M87) 6212 Alamo, St. Louis, MO 63105. Dy: (314) 291-4146. Res: (314) 721-0097. S: Ellen. Job: Mgr, Prog Dev, Grumman Corp. Svc: USA. Ret: 87. 20 yrs. Past VP, Phantom Corps Chapter.

MELSON, Walton R., (CW4) (M71) (Walt) 314 Westwind Circle, San Antonio, TX 78239-1938. Dy: (512) 655-0022. Res: (512) 657-4773. S: Tert. Job: Proj Dir., Bldg. Office, City of Windcrest, TX. Svc: USA. Ret: 84. 30 yrs. Past VP, Jack H. Dibrell/Alamo/.

MERRYMAN, James H., (LTG) (M57) (Jim) 7830 Bellefour Drive, Springfield, VA 22152. Dy: (703) 569-7331. Res: (703) 569-7331. S: Jane. Svc: USA. Ret: 84. 33 yrs. NEB. Past Sec, Washington DC Chapter.

MERTEL, Kenneth D., (COL) (M57) (Route 4) Box 220, Fort Merte, Smithfield, VA 23430. S: Mollie. Svc: USA. Ret: 75. 33 yrs. Past Pres.

MEYNDT, Rene, (CW4) (M73) Jakob Klarstr. 1, 8000 Munchan 40, West Germany. Res: 089-27-4478 (FRG). S: Petra. Svc: USA. Ret: 87. 26 yrs. Past Sec, Stuttgart Chapter.

MIALARET, Gerard J., (COL) (M57) (Cajun) 1328 Melody Drive, Metairie, LA 70002. Res: (504) 834-4513. S: Ida. Job: Lobbyist. Svc: USA. 32 yrs.

MIKULA, J. George, (COL) (M57) (George) 6708 Spirea Court, Fort Wayne, IN 46804. Dy: (219) 487-3021. Res: (219) 672-3482. S: Elizabeth. Job: Mgr Adv Ping, ITT AeroSp. Svc: USA. Ret: 81. 27 yrs.

MIKUTA, Joel J., (COL) (M59) 409 Hickory Bend Road, Enterprise, AL 36330. Res: (205) 347-3266. S: Jean. Svc: USA. Ret: 84. 28 yrs.

MILLER, Christian J., (LTC) (M62) (Chris) 663

Romeo Court, Pleasanton, CA 94566-7788. Dy: (415) 462-2885. Res: (415) 462-1311. S: Marty. Past Pres.

MILLER, John D., (LTC) (M85) (John) 18682 Beach Bl, No. 255, Huntington Beach, CA 92648-2052. S: Fran. Job: Program Manager, Northrop. Svc: USA. Ret: 87. 21 yrs.

MILLER, Paul B., (CW4) (M69) Rr 20, Box 431, San Antonio, TX 78218. Res: (512) 651-9718. S: Evelyn. Svc: USA, USAF, USN. Ret: 71. 28 yrs.

MILLER, Raymond A., (MAJ) (M57) (Ray) 10835 Cascade Drive, Dubuque, IA 52001. Res: (319) 582-2690. S: Marybeth. Svc: USA. Ret: 57. 20 yrs.

MILLER, Richard E., (LTC) (M60) (Dick) 7741 S.W. 182 Terrace, Miami, FL 33157. Dy: (305) 246-5300. Res: (305) 251-8950. S: Sigrid. Job: Exec VP, Amnet Financial Corp. Svc: USA. Ret: 75. 20 yrs.

MILLER, Terry L., (MAJ) (M64) 2373 Pagely Place, Bartlett, TN 38134. Dy: (901) 682-6922. Res: (901) 372-3465. S: Carolyn. Job: Sr. Army Instructor, Memphis City. Svc: USA. Ret: 84. 20 yrs.

MILLER, William R., (LTC) (M57) (Bill) 6050 Gallen Court, Port Orange, FL 32019. Res: (404) 788-8445. S: Gertrude. Svc: USA. Ret: 62. 20 yrs.

MILLS, Jon R., (LTC) (M62) 7861 Hampton Village Pass, Annandale, VA 22003. Dy: (703) 284-6203. Res: (703) 698-5469. Job: Prog. Mgr, Space Systems Div., G.E. Svc: USA. Ret: 80. 20 yrs.

MILLS, Robert W., (COL) (M68) (Bob) 5863 Oak Run, San Antonio, TX 78247. Res: (512) 656-1015. S: Joanne. Svc: USA. Ret: 79. Past Sec.

MINGUS, Leslie C., (LTC) (M79) (Charlie) 219 Laurel Breton Drive, Enterprise, AL 36630. Dy: (205) 393-1521. Res: (205) 347-7555. S: Carol. Job: Southeast Regional Mgr, Cobro. Ret: 87. 20 yrs.

MINKINOW, Stanley, (MAJ) (M53) 2904 Bardsody Road, Huntsville, AL 35801. Dy: (205) 536-3322. Res: (205) 883-5103. S: Doris. Job: Owner, Coin Investors, Huntsville, AL. Svc: USA. Ret: 79. 26 yrs.

MIYAMOTO, Atsushi A., (LTC) (M62) 23825 Passatiempo Lane, Harbor City, CA 90710. Dy: (213) 637-8874. Res: (213) 539-9635. S: Kay. Job: Exec VP & Dir, Maruzens of America, Inc. Svc: USA. Ret: 79. 29 yrs.

MOCCYGENBA, Norbert W., (CW4) (M81) (Mocxy) 16802 Fort Osage, San Antonio, TX 78247-1036. Dy: (512) 925-5171. Res: (512) 657-4444. S: Eleanor. Job: Safety & Occup. Health Spec., Civil Serv., Kelly AFB. Svc: USA, USN. Ret: 69. 25 yrs.

MOELLER, Gene L., (LTC) (M58) 9724 Stone Henge Lane, Knoxville TN 37922. Dy: (615) 974-1219. Res: (615) 693-3183. S: Betty. Job: Asst Athletic Dir, U of TN. Ret: 76. 22 yrs.

MOELLER, Lawrence B., (LTC) (M59) (Larry) 1907 Silver Creek Place, Duncanville, TX 75137. Res: (214) 780-9197. S: Barbara. Svc: USA. Ret: 87. 35 yrs. Past Sec, Follow Me Chapter.

MONEY, David H., (LTC) (M58) (Dave) 4960 Pennsylvania Ave SE, Salem, OR 97301. S: Irma. Svc: USA. Ret: 69. 20 yrs.

MONOC, David M., (MSG) (M68) (Dave) 1214

M The SpOOF Roster

Longmeadow Street, Longmeadow, MA 01106. Dy: (203) 243-6151. Job: Field Service Rep, Kaman Aerospace Corp. Svc: USA. Ret: 65. 20 yrs.

MONROE, Melvin C., (LTC) (M58) 7110 S.E. Yamhill Street, Portland, OR 97215. Dy: (503) 352-7501. Res: (503) 252-8367. S: Dorothy. Svc: USA. Ret: 66. 24 yrs. Past Pres, Southern California Chapter.

MONTGOMERY, Homer T., (LTC) (M57) 5517 Golf Club Drive, Diamondhead, Bay St. Louis, MS 39520. Res: (601) 255-9309. S: Chris. Ret: 64. 24 yrs.

MONTGOMERY, Michael E., (MR.) (M84) (Mike) Cobro Corporation, P.O. Box 397, Daleville, AL 36322. Dy: (205) 598-6302. Res: (205) 792-1673. S: Thess. Job: PM, Cobro Corp. Svc: USA. Ret: 80. 22 yrs.

MOONJIAN, V. Wayne, (LTC) (M88) 400 S. Industrial Drive, Suite 212, Eules, TX 76040. Dy: (817) 267-3351. S: Lynne. Job: Dir of Ops, Chromalloy Avn Svcs Int'l, Chromalloy Aero Svcs. Svc: USA, USAF. Ret: 86. 20 yrs.

MOORE, Eddie E., (LTC) (M72) (Ed) 2209 Acacia Street, Richardson, TX 75082. Dy: (214) 272-0515. Res: (214) 680-2228. S: Dorothy. Job: Asst to VP & Gen Mgr, Garland Div, E-Systems. Svc: USA. Ret: 82. 23 yrs. Past Pres, North Texas Chapter.

MOORE, Howard M., (COL) (M58) 1921 Bay Oaks Court, Fort Worth, TX 76112. Res: (817) 457-0876. S: Phyllis. Svc: USA. Ret: 75. 33 yrs. Past VP, Arizona Chapter.

MOORE, James E., (LTC) (M58) (Jim) 5353 Black Oak Drive, Fairfax, VA 22032. Dy: (703) 939-5600. Res: (703) 250-9777. S: Betty. Job: Realtor, Coldwell Banker, Vienna, Svc: USA. Ret: 80. 28 yrs.

MOORE, Jimmy N., (LTC) (M57) (Jim) 41747 Borealis Drive, Rancho California, CA 92390. Dy: (714) 676-1242. Res: (714) 676-1960. S: Peggy. Job: Pres., Topmast Inc. Svc: USA. Ret: 74. 21 yrs.

MOORE, Peter W., (LTC) (M60) (P.W.) Route 6, Box 52, Marianna, FL 32446. Res: (904) 482-5212. S: Rebecca. Job: Self-employed, Antique Clock Repair. Svc: USA. Ret: 81. 30 yrs.

MOORE, Robert K., (COL) (M58) (Bob) 1327 Continental Avenue, Melbourne, FL 32940. Res: (407) 255-6665. S: Ryanna. Svc: USA. Ret: 69. 27 yrs. Past NEB. Past Sr VP, Chesapeake Bay Chapter.

MORGAN, George A., (COL) (M59) General Motors Corp., 1911 N Ft Myer Dr-800, Arlington, VA 22209. Dy: (703) 284-1751. Res: (703) 455-3580. S: Rita. Job: Mgr, Wash. Office. Ret: 83. 24 yrs. Past Pres, Coastal Empire Chapter.

MORGAN, Robert K., (SFC) (M83) (Bob) Route 3, Box 25, Enterprise, AL 36330. Dy: (205) 255-6486. Res: (205) 347-8071. S: Sachiko. Job: Engr Tech, DA. Svc: USA. Ret: 71. 21 yrs.

MORRIS, Dennis L., (MAJ) (M66) (P.O.) Box 855, Ormond Beach, FL 32074. Dy: (904) 441-1100. Res: (904) 672-6493. S: Mary Anne. Job: Realtor, Broker/Salesman, Adams, Cameron Rly Wtd, Br Mgr/Tsmg Dir. Svc: USA.

Ret: 83. 20 yrs.

MORRIS, J. J., (COL) (M63) (J.J.) 2309 S. Macon Street, Aurora, CO 80014. Dy: (303) 842-8891. Res: (303) 751-7998. S: Marilyn. Job: Vp Operations, Aerojet Inc., Titilamook, OR. Svc: USA. Ret: 77. 26 yrs. Past Pres, Hanau Chapter.

MOSES, George W., (LTC) (M63) 2906 Chaucer, Killeen, TX 76543. Dy: (817) 690-4000. Res: (817) 634-4139. S: Sharon. Job: Acacia Mutual Life, Acct Mgr. Svc: USA. Ret: 77. 21 yrs.

MOULDER, E. Dennis, (MAJ) (M72) (Moe) 4022 Apollo Drive, Huntsville, AL 35805. Dy: (205) 882-4519. Res: (205) 551-0712. S: Margaret. Job: Pgm Mgr, Acft Sys Sci Technology, Inc. Svc: USA. Ret: 87. 20 yrs.

MOUNTCASTLE, Arthur M., (MAJ) (M75) (Monty) 1341 Golfview Drive, Daytona Beach, FL 32014. Dy: (904) 257-6276. Res: (904) 257-6276. Job: President, Mountcastle Inc., Safety Consultant. Svc: USA. Ret: 80. 20 yrs. Past Sec, Air Assault Chapter, 76 McClellan Award.

MOUNTS, Leonard J., (CW4) (M57) (Len) 201 Walnut Drive, Enterprise, AL 36330. Res: (205) 347-7429. S: Janet. Svc: USN, USMC. Ret: 68. 27 yrs.

MOUW, James W., (LTC) (M64) (Jim) Rockwell Int'l MSD, 1800 Satellite Blvd., Duluth, GA 30136. Dy: (404) 564-4590. Res: (404) 945-7563. S: Marguerite. Job: Mgr, Logis, MS Div, Rockwell Int'l. Ret: 83. 21 yrs. Past VP, Lindbergh Chapter.

MRAZIK, William W., (COL) (M79) (Bill) Contec, Inc., 17 Merriam Road, Framingham, MA 01701. Dy: (617) 877-5035. Res: (617) 877-5035. S: Naka. Job: Pres., Contec, Inc. Svc: USAF. Ret: 74. 28 yrs.

MULHOLLAND, John D., (CW0) (M64) (Jack) 1339 Tanyard Lane, Pasadena, MD 21122. Dy: (301) 798-3600. Res: (301) 437-5264. S: Kyung. Job: District Mgr, STS Int'l, Inc. Svc: USA, USMC. 16 yrs.

MULVANEY, Merle L., (LTC) (M59) 9026 Ashmeade Drive, Fairfax, VA 22032. Dy: (703) 698-5560. Res: (703) 323-6871. S: Janet. Job: Vp Exec Recruitment, Cacy Assoc, Fairfax. Svc: USA. Ret: 80. 21 yrs.

MURRAY, George W., (CW3) (M58) 1979 Old Town Road, Bridgeport, CT 06606. Dy: (203) 384-7216. Res: (203) 371-0814. S: Erma. Job: Tech Writer, Sikorsky Acrt. Svc: USA. Ret: 69. 21 yrs.

MUSCHEK, Robert W., (LTC) (M64) (Bob) 11867 Cog Hill Drive, Whittier, CA 90601. Dy: (213) 942-3970. Res: (213) 692-0574. S: Miriam. Job: Reliability Manager - Northrop. Ret: 82. 21 yrs.

MUSSON, Richard W., (LTC) (M79) (Dick) 7705 Grainick Place, Springfield, VA 22153. Dy: (703) 264-0900. Res: (703) 455-0896. S: Debbie. Job: Asst Mgr, Blinder Robinson & Co, Inc. Svc: USA. Ret: 87. 21 yrs.

NNNNNNNNNN

NAKAJO, Mas M., (COL) (M58) (Nick) 16602 Sequoia Street, Fountain Valley, CA 92708. Res: (714) 839-8053. S: Marie. Svc: USA. Ret: 81. 33 yrs.

NANARTOWICH, Richard H., (COL) (M58) (Dick) 33 Avon Drive, Hudson, MA 01749.

(508) 443-5328. Res: (508) 562-2400. S: Rita. Job: Sales Associate, J.M. Flynn Real Estate. Svc: USA. Ret: 86. 36 yrs.

NASCHE, John, (MAJ) (M88) (Andy) Bell Learning Center, 9601 Trinity Blvd, Fort Worth, TX 76053. Dy: (817) 280-2945. Res: (817) 485-1137. S: Su. Job: Mgr, Bell Learning Ctr, Flight Safety Int'l. Svc: USA. Ret: 74. 20 yrs.

NEAMTZ, John C., (MAJ) (M57) 304 Blacklatch Lane, Camp Hill PA 17011. Dy: (717) 790-3412. Res: (717) 737-0024. S: Mary. Job: Director Ind Pit Equip Ctr, DIPECM, Mechanicsburg. Svc: USA. Ret: 66. 21 yrs.

NEEDLES, Paul E., (COL) (M58) 127 Schooner Drive, Hampton, VA 23669. Dy: (703) 276-3100. Res: (804) 851-2057. S: Sherry. Job: Consultant, Kraser Eng. Inc. Ret: 80. 27 yrs.

NEEL, Spurgeon H., (MG) (M60) 1321 Spanish Oaks, San Antonio, TX 78213. Dy: (512) 567-5930. Res: (512) 349-6757. S: Alice. Job: Prof Doc & Aerosp Medicine, Univ TX, Sch of Public Health. Svc: USA. Ret: 77. 35 yrs. 61 McClellan, HOF.

NEELSON, Huoy, R. (CW4) (M57) (Silver Fox) P.O. Box 97, APO New York 09712. Dy: FRG 02843-70-6629. Res: FRG 02801-4218. S: Anne. Job: Chief, Classification Div, Civ Personnel Ofc, 54th ASG. Svc: USA. Ret: 70. 20 yrs.

NEU, George T., (LTC) (M58) (Ted) 8 Neal Drive, Simsbury, CT 06070. Dy: (203) 243-7123. Res: (203) 851-3412. S: Betty. Job: PM Mgr, Kaman Aerosp, Bloomfield. Svc: USA. Ret: 75. 21 yrs.

NEUMAN, Rudolph D., (MR.) (M67) (Rudy) 7 Monmouth Road, Oakhurst, NJ 07755. Res: (201) 222-4327. S: Laine. Job: Prof Eng, P.E. Svc: USA.

NEVINS, Robert H., Jr., (COL) (M83) (Bob) Hcr 61 Box 17b, Norfolk, AR 72658. Res: (501) 499-7539. S: Barbara. Ret: 75. 27 yrs. HOF.

NEWCOMER, Samuel K., (SFC) (M64) (Sam) 968 Raford Court, Bellefontaine Neighbors, St. Louis, MO 63137. Dy: (314) 739-6965. Res: (314) 869-8539. S: Peggy. Job: Top Eng, General Atomics. Ret: 63. 22 yrs.

NEWPORT, Dennis E., (LTC) (M58) 2901 Archer Court, Woodbridge, VA 22193. Dy: (202) 274-7773. Res: (703) 670-4788. S: Carol. Job: Air Traf Cont Spec, Army Aero Svcs Off, Cameron Sta. Svc: USA. Ret: 74. 21 yrs.

NEWTON, Albert, (COL) (M58) (Al) 362 Hopemond Circle, Hampton VA 23669. Res: (804) 851-5246. S: Blanche. Svc: USA. Ret: 72. 31 yrs. Past Pres.

NEWTON, Robert W., (COL) (M64) (Bob) 3522 Laurel Leaf Lane, Fairfax, VA 22031. Dy: (703) 659-3111. Res: (703) 260-5461. S: Linda. Job: Pres, Hidden Valley Corp. Svc: USA. Ret: 80. 25 yrs. Past VP, Washington DC Chapter.

NICHOLS, Frank S., (LTC) (M57) (Nick) 3862 Meadow Lane N.E., Marietta, GA 30062. Dy: (404) 659-8516. Res: (404) 992-2572. S: Bette. Job: Branch Mgr, Wells Fargo Alarm Svcs, Atlanta. Svc: USA. Ret: 68. 22 yrs.

NICHOLSON, Frederick C. (CW4) (M59) (Nick) 402 Colonial Drive, Enterprise, AL 36330. Res: (205) 347-3307. S: Helen. Svc: USA. Ret: 75. 30 yrs. Past VP, Mid-America Chapter.

NICHOLSON, Rowland J., (LTC) (M58) (Nick) 10306 Musket Court, Fort Washington, MO 20744-3921. Dy: (202) 692-2881. Res: (301)

N The SPOOF Roster

292-1438. S: Maureen. Job: Suprv Logis E-6A, Tacamo, Navalair Sys, Wash, DC. Svc: USA. Ret: 74. 22 yrs.

NIELSEN, Edward L., (COL) (M57) (Ed) 122 Lakeshore Dr, Apt 833, North Palm Beach, FL 33408. Res: (305) 622-6735. S: Mary. Job: Pres, Nielsen Consulting Svc. Svc: USA. Ret: 69. 30 yrs. NEB. Past VP, Del Valley Chapter.

NISSEN, Thomas R., (LTC) (M71) 505 Pilgrim, Friendswood, TX 77546. Res: (713) 996-8669. S: Patricia. GS: 12. Svc: USA. Ret: 81. 34 yrs. Past Sr VP.

NOACK, Richard R., (COL) (M62) (Dick) 15242 Bent Moss, San Antonio, TX 78232. Dy: (512) 366-4426. Res: (512) 490-6272. S: Mary. Job: Ins & Invest Broker, NE Life. Svc: USA. Ret: 85. 26 yrs. Past NEB.

NOVSEK, Michael J., (CW4) (M71) (Mike) 202 Oakwood Drive, Enterprise, AL 36330. Res: (205) 347-7265. S: Ethel. Svc: USA, USAF. Ret: 85. 44 yrs. Past NEB. Past Pres, Normaling Calm Chapter. HOF.

NOWALK, Charles L., (COL) (M56) 3513 Stratfield Drive, Atlanta, GA 30319-2532. Dy: (404) 255-5199. Res: (404) 365-0016. S: Jane. Job: Sales Assoc, Jack Anderson & Assoc Ltd. Svc: USA. Ret: 83. 32 yrs.

NUTT, Merwyn L., (COL) (M84) 2208 Shadydale Drive, Arlington, TX 76012-5426. Dy: (214) 929-0877. Res: (817) 860-7390. S: Mary. Job: Sr VP, Imagining Sys Corp. Svc: USA. Ret: 88. 26 yrs.

NUTTER, Raymond T., (COL) (M86) 731 Old Scottsville Road, Bowling Green, KY 42101. Dy: (502) 781-9696. Res: (502) 781-3430. S: Jean. Job: Pres., Ray Nutter Construction Co. Svc: USA. Ret: 78. 27 yrs.

0000000000

OBBER, Robert E., (COL) (M60) (Bob) 7614 Jomel Drive, Spring Hill, FL 34607. Res: (904) 596-3838. S: Dottie. Ret: 82. 28 yrs. Past Sr VP, Aloha Chapter.

OBERRHIRE, John P., (COL) (M62) Rte 7, Box 638, Eatonville Rd., Hattiesburg, MS 39401-8413. Dy: (601) 584-7388. Res: (601) 584-7388. S: Bill. Job: Grad Student U of So. Ms. Ret: 84. 30 yrs.

O'BRIEN, Loraine M., (MS.) (M85) 230 S. Brentwood Blvd, Apt. 7D, Clayton, MO 63105. Dy: (314) 863-6236. Svc: USA. Ret: 79. 22 yrs. Past Pres, Lindbergh Chapter.

ODEN, James R., (CW4) (M58) 1551 Shady Grove Road, Hot Springs, AR 71901. Res: (501) 262-1174. S: Raylene. Svc: USA. Ret: 73. 28 yrs.

O'DONOHUE, John D., (COL) (M58) (Jack) 5900 Invalide Drive, Fairfax Station, VA 22039. Dy: (703) 556-9520. Res: (703) 239-1212. S: Janice. Job: Pres/CEO, Bickerton Home Builders. Svc: USA. Ret: 79. 28 yrs. Past Pres, Aloha Chapter.

O'FHELLY, Jeremiah, (MAJ) (M66) (Jerry) 116 Crescent Drive, Kernville, TX 78029-3002. Dy: (512) 896-4835. Res: (512) 896-0457. S: Judy. Job: Sales Rep, Crenewe Motors. Svc: USA, USN. Ret: 86. 21 yrs.

OGLESBY, Carmen S., (MRS) (M70) 28 Nottingham Road, Apt. 1, Little Rock, AR 72205. Res: (501) 664-5162. S: Hilton.

OGLETREE, Clarence, (1SG) (M57) (Tree) 2875 Londonderry Drive, Sacramento, CA 95827. Res: (916) 362-4022. S: Ruby Lee. Svc: USA. Ret: 71. 22 yrs.

OHARA, Daniel, (LTC) (M57) 1301 41st Ave., NE, St Petersburg, FL 33703. Dy: (305) 296-4658. Res: (813) 526-0338. S: Bernice. Job: Chm of the Board/Pres., Do & Sons, Stan & Dan. Svc: USA, USMC. Ret: 68. 23 yrs.

OLDFENDT, Glendon E., (COL) (M57) (Glen) 2825 St. Michael Drive, Missoula, MT 59803. Res: (406) 251-5657. S: Peggy. Svc: USA. Ret: 70. 28 yrs.

ORDWAY, Frank A., (MSG) (M79) 1217 Wallen Street, Midland, MI 48640. Res: (517) 835-7156. S: Pauline. Job: Maint Dept., Dow Corning HSC, Hemlock. Svc: USA. Ret: 80. 21 yrs.

OSBORN, Larry N., (COL) (M66) 4608 Pickett Road, Fairfax, VA 22032. Dy: (703) 356-1323. Res: (703) 978-1350. S: Juanita. Job: Mgr, McLean Office, Town & Country Property. Svc: USA. Ret: 84. 26 yrs.

OSBORNE, Walton H., III, (LTC) (M60) 940 Marie Rochele Dr, West Chester, PA 19382. Dy: (302) 479-2846. Res: (215) 692-6782. S: Denise. Job: Warranty Mgr, Rollins Leasing Corp. Svc: USA. Ret: 79. 24 yrs.

OSWALT, John W., (COL) (M58) (Johnny) 5917 Jacqueline Road, Fort Worth, TX 76112. Res: (817) 451-3459. S: Barbara. Job: Mgr, Bell Hcpr Textron. Svc: USA. Ret: 63. 23 yrs. Past NEB. HOF.

OWENS, Alan E., (CSM) (M74) 8620 N. 106th Lane, Peoria, AZ 85345. S: Doris. Svc: USA. Ret: 79. 24 yrs. Past VP, Air Assault Chapter.

PPPPPPPPPP

PACKER, Jacob L., (MAJ) (M57) (Pack) 6304 Circleview Drive, Fort Worth, TX 76180. Res: (817) 281-2959. S: Fern. Svc: USA. Ret: 63. 22 yrs.

PAQUETTE, Dean R., (COL) (M57) (Dean) Control Data Corporation, 1117 Priscilla Lane, Alexandria, VA 22308. Dy: (703) 998-3569. Res: (703) 780-9445. S: Shirley. Job: Mgr Def Planning. Svc: USA. Ret: 76. 30 yrs.

PARK, Sun B., (MAJ) (M81) (Sunny) 4061 Freed Ave., San Jose, CA 95117-3409. Res: (408) 247-3935. S: Jeanny. Svc: USA. Ret: 88. 20 yrs.

PARNELL, James I., (CW4) (M63) (Jim) 2018 Hilltop Street, Belton, TX 76513. Dy: (817) 939-3517. Res: (817) 939-0360. S: Geraldine. Job: Inventory Cntrl Mgr, Superior Chiropract. Svc: USA. Ret: 81. 22 yrs.

PARNELL, Robert L., Jr., (COL) (M72) (Bob) AAAA Sch Foundation Board, 9013 Vernon View Drive, Alexandria, VA 22308. Res: (703) 360-1739. S: Mary. Svc: USMC. Ret: 72. 30 yrs.

PARRISH, Glenwood H., (COL) (M59) (Mickey) 504 Woodmont Drive, Staunton, VA 24401-2167. Res: (703) 886-2990. S: Anna. Ret: 85. 30 yrs.

PARROTTE, Stanley R., (MSG) (M75) (Stan) 11707 Spotted Horse Drive, Austin, TX 78759. Dy: (512) 331-9072. Res: (512) 345-8664. S: Tae. Job: Mgr, OK Liquors, Austin; Pres, KST

Corp. Svc: USA, USN. Ret: 80. 28 yrs.

PARTHEYMULLER, Richard R., (MAJ) (M69) (Rich) Rt 2, Box 324, Copperas Cove, TX 76522. Dy: (817) 634-2228. Res: (817) 547-8171. S: J. J. Svc: Assoc Staff Membr, The BDM Corp. Svc: USA. Ret: 88. 23 yrs.

PARUTI, Alexander, (LTC) (M64) (A) 8713 Pine Needles Court, Vienna, VA 22180. Dy: (703) 750-2037. S: Kathy. Job: Pgm, Mgr., Nat'l Sys Mgmt Corp. Ret: 81. 20 yrs.

PASSANO, John D., (LTC) (M58) 4672 South Foster Road, San Antonio, TX 78222. Dy: (512) 648-4800. Res: (512) 648-3481. S: Jo. Job: Owner/Hero's Feed & Chief Pilot/Mac String Fellow Investments. Svc: USA. Ret: 74. 25 yrs. Past VP, Phantom Corps Chapter.

PATE, Robert I., (COL) (M60) (ROBERT I) 7140 Dunhill Terrace, Atlanta, GA 30328-1221. Res: (404) 396-6775. S: Meada. Svc: USA. Ret: 85. 31 yrs.

PATLA, N.I., (COL) (M63) (Norb) 37 Champagne Drive, Lake St. Louis, MO 63044. Dy: (314) 298-0000. Res: (314) 825-2112. S: Judy. Job: Dir, Mil Requirements, Midwest Region, Link Fit Simulation Corp. Svc: USA. Ret: 86. 24 yrs. VP, Lindbergh Chapter.

PATNODE, Clarence A., (COL) (M58) (Bud) 8746 So. Ruster Road, Sandy, UT 84093. Dy: (801) 943-6339. Res: (801) 943-6534. S: Elaine. Job: President, Capcon, Ltd. Svc: USA. Ret: 80. 26 yrs.

PATTERSON, James H., (MG) (M59) (Jim) 1075 Bogyey Lane, Longboat Key, FL 34628. Dy: (813) 388-1951. Res: (813) 383-8647. S: Barbara. Job: Dir, Field Operations, SINNET. Svc: USA. Ret: 80. 28 yrs. Past Sr VP, Phantom Corps Chapter.

PATTERSON, John F., (LTC) (M58) (Pat) 2903 St. Andrews Drive, Richardson, TX 75082. Dy: (214) 788-9540. Res: (214) 644-0249. S: Sheila. Job: VP, Group Sales, Hartford GP, Dallas. Svc: USA. Ret: 73. 20 yrs. Past VP.

PATTERSON, Harry D., Jr., (LTC) (M77) 7194 Broad Street, Rural Hall, NC 27045. Dy: (919) 368-2521. Res: (919) 969-6483. S: Caroline. Job: Sr Army Instructor, JROTC, East Surry HS, Pilot Mtn. Svc: USA. Ret: 88. 22 yrs. Past VP, Wings of the Marne Chapter.

PEARSON, Neville A., (LTC) (M57) 44 East Governor Drive, Newport News, VA 23628. Res: (804) 877-6996. S: Betty. Ret: 70. 26 yrs. Past VP.

PENDELTON, Elmer D. Jr., (MG) (M76) (Elmer) 3028 Knoll Drive, Falls Church, VA 22042. Dy: (703) 241-0236. Res: (703) 532-1851. S: Anne. Job: Consultant. Svc: USA. Ret: 86. 37 yrs.

PENNYPACKER, John E., Jr., (MAJ) (M66) 955 N. Seton, Mesa, AZ 85205-5449. Dy: (602) 891-2500. Res: (602) 981-6541. S: Betsy. Job: Tech Staff, McDonnell Douglas Hcpr. Svc: USA. Ret: 85. 20 yrs. Past Sec, Colonial Virginia Chapter.

PERSHING, Jay W., (COL) (M59) 89 Hop Brook Road, Simsbury, CT 06070. Dy: (203) 243-7050. Res: (203) 651-0148. S: Mary. Job: VP, Material, Kaman Aerosp. Corp. Svc: USA. Ret: 80. 26 yrs.

PETERS, John W., (LTC) (M62) (Jack) 17 Lantern Lane, Chelmsford, MA 01824. Dy: (607) 377-6150. Res: (508) 256-4376. S: Jeanne. Job: Project Leader, RJO Systems Engrng. Svc: USA. Ret: 80. 22 yrs.

P The SPOOF Roster

PETERSEN, Darwin A., (COL) (M58) (Pete) 1617 Fremont Lane, Vienna, VA 22180. Dy: (703) 761-2815. Res: (703) 759-9684. S: Rosemary. Job: Pgm Mgr, Ball South Government Systems. Svc: USA. Ret: 80. 26 yrs. Past Pres, Monmouth Chapter.

PETERSON, Jon M., (LTC) (M64) (Jon) Route 2, Box 491, Copperas Cove, TX 76522. Dy: (817) 547-8128. Res: (817) 547-9832. Job: Mfg Loan Solicitor, Cove State Bank. Svc: USA. Ret: 85. 26 yrs.

PETERSON, Richard N., (LTC) (M63) (Pete) 446 E. Lincoln Trail, Radcliff, KY 40160. Dy: (502) 624-7010. Res: (502) 351-1494. S: Patt. Job: USAAREND Equip Svc, Fort Knox. Svc: USA. Ret: 78. 26 yrs.

PETTY, Floyd E., (COL) (M58) 1120 Cedar Hills, Route 2, Fredericksburg, TX 78764. Dy: (512) 997-8973. Res: (512) 997-8966. S: Mickie. Job: County Chmn, Republican Party of Gillespie Co. Svc: USA. Ret: 75. 30 yrs. Past Pres, Monmouth Chapter.

PETTY, Lloyd J., (COL) (M58) 8803 Silverwood Court, Austin, TX 78759. Dy: (512) 343-7969. Res: (512) 345-0858. S: Lyn. Job: VP/Secy, Blooms II Inc. Svc: USA. Ret: 75. 30 yrs. Past Pres, Old Tucson.

PETTY, Phares B., (MAJ) (M67) (Bud) P.O. Box 1, Crestview, FL 32536. Res: (904) 897-3483. S: Gracie. Ret: 78. 20 yrs.

PHELPS, Jon H., (CW3) (M61) Ross Aviation Inc., Box 9124, Albuquerque, NM 87119. Dy: (505) 844-1198. Res: (505) 839-9530. S: Fran. Ret: 87.

PHELPS, Lloyd C., (MAJ) (M74) 1509 Elmwood Ave, Worthington, MN 56187. Dy: (507) 372-8285. Res: (507) 376-4980. S: Marian. Job: Duveville Probation Agent, Nobles Cty. Svc: USA, USMC. Ret: 80. 26 yrs.

PHILLIPS, Donald W., (LTC) (M57) 915 Dawn Street, Venice, FL 34285. Dy: (813) 485-9602. Res: (813) 485-5805. S: Betty June. Job: Realtor, Azure Realty, Inc. Svc: USA. Ret: 70. 20 yrs.

PHILLIPS, Wayne N., (COL) (M57) (Ace) 144 Oak Shadow Drive, Santa Rosa, CA 95409. Res: (707) 539-1954. Svc: USA. Ret: 71. 33 yrs. Past NEB, Past Pres.

PHILLIPS, Wm. Gene, (COL) (M57) (Gene) P.O. Box 825, Osage Beach, MO 65065. Res: (314) 348-2615. S: Marie. Svc: USA, USN. Ret: 73. 30 yrs. Past VP, Lindbergh Chapter.

PICKENS, Robert B. Jr., (COL) (M61) (Easy) Fieldstones, 10 Old Rock Court, West Norwalk, CT 06850. Res: (203) 838-1638. S: Georgia. Svc: USA, USAF. Ret: 76. 34 yrs.

PICKETT, Malcolm L., (SGM) (M71) (Mac) 2005 Pleasant Lane, Copperas Cove, TX 76522. Dy: (817) 532-8546. Res: (817) 547-4038. S: Gerda. Job: Field Suprsvr, Avn SDC, Cobro Corp. Svc: USA. Ret: 85. 30 yrs. Past VP, Phantom Corps Chapter.

PIERCE, Fred W., Jr., (LTC) (M57) 8135 Lakeridge Drive, S.E. Olympia, WA 98503. Dy: (206) 491-5559. Res: (206) 491-5559. S: Phyllis. Job: Pres & Bus Consultant, Pierce & Pierce Unlimited. Svc: USA. Ret: 76. 22 yrs.

PIERCE, John T., III, (COL) (M57) (Jack) 1385 Cleveland Hill Road, Roseburg, OR 97470. Res: (503) 672-5430. S: Mary. Job: Pierces' Plants. Svc: USA. Ret: 68. 25 yrs. Past Tre, Delaware Valley Chapter.

PITTMAN, Charles D., (LTC) (M58) (Dan) 540 Vanderbilt Avenue, Virginia Beach, VA 23451. Dy: (804) 227-2477. Res: (804) 425-8827. S: Dorothy. Job: Mgmt Analyst, Org Dir DCSSD Hq TRDDC. Svc: USA, USN. Ret: 69. 21 yrs.

PITTMAN, CIH, (COL) (M88) 5747A Adobe Falls Road, San Diego, CA 92120. Res: (619) 286-5539. S: Thelma. Svc: USA. Ret: 68. 30 yrs.

PITTS, Russell N., (COL) (M61) (Russ) P.O. Box 511, Monument, CO 80132. Dy: (719) 633-5588. Res: (719) 488-2561. S: Edna. Job: Sr VP, American Air Jet, Inc. Svc: USA. Ret: 76. 24 yrs. Past Pres.

PLISSEY, Robert D., (LTC) (M58) (Bob) 31 Toomin Drive, Neptune, NJ 07753. Dy: (201) 544-1077. Res: (201) 922-3035. S: Margaret. Job: Sr Engr, Analytics, Inc. Svc: USA. Ret: 75. 20 yrs.

PLUMMER, Dirk A., (COL) (M85) (Dirk) 45 Village Road, Sea Bright, NJ 07760. Dy: (212) 280-7679. Res: (201) 747-0858. Job: Professional Engr, Dirk Arnold Plummer. Svc: USA. Ret: 82. 30 yrs.

POHLEN, Jerome J., (COL) (M58) (Jerry) Cessna Aircraft Co, 1745 Jeff Davis Hwy, 1000, Arlington, VA 22202-3487. Dy: (703) 553-1281. Res: (703) 356-1612. S: Ethel. Job: Dir, Govt Ret, Cessna Aort Co. Svc: USAF. Ret: 77. 31 yrs.

POOL, Thomas C., (LTC) (M66) (Tom) 103 Grayson Drive, Enterprise, AL 36330. Dy: (205) 598-9598. Res: (205) 347-4469. S: Helen. Job: General Mgr, REMTECH, Inc. Svc: USA. Ret: 87. 25 yrs. Past Pres, Bonn Area Chapter.

POSS, Charles A., (LTC) (M70) (Chuck) P.O. Box 848, Ence, NC 28728. Dy: (704) 667-7258. Res: (704) 667-3536. S: Barbara. Job: U.S. Postal Service. Svc: USA. Ret: 71. 23 yrs.

POST, Alton G., (MG) (M58) (Al) Dyncorp, 2000 Edmund Halley Drive, Reston, VA 22091. Dy: (703) 264-9213. S: Marilyn. Job: Director Bus Dev, Gov't Svcs Grp, Dyncorp. Svc: USA. Ret: 78. 40 yrs. Former 1st Reg Pres.

POTEAT, James D., (COL) (M62) (Jim) 3300 Flat Shoals Road, Conyers, GA 30207. Dy: (404) 922-9740. Res: (404) 922-9740. S: Clara. Job: Pres, JLI Enterprises. Svc: USA. Ret: 83. 26 yrs. Past Sr VP, Greater-Atlanta Chapter.

POTTER, Russell E., (LTC) (M58) (Russ) 5440 South Shore Drive, Whitehall, MI 49461. Res: (616) 893-4635. S: Phyllis. Ret: 79. 25 yrs. Past VP, Army Avn Center Chapter.

POTTS, Bonnie B., (CW4) (M57) 406 South Adams, Junction City, KS 66441. Dy: (913) 239-4101. Res: (913) 238-3928. S: Mildred. Job: Equip Spec., R. Riley. Svc: USA. Ret: 68. 24 yrs. Past Pres, Mid-America Chapter.

POUNCEY, John E., (MAJ) (M83) (Ed) 42d MP GP-Box 94, APO NY 09008-5374. Dy: AV/ETS 380-8223-6931. Res: FRG 49-6221-3871-28. Job: Chf of Plans, Security, & Exercises, 42d Mil Police Grp. (Customs). Svc: USA. Ret: 86. 20 yrs.

POWELL, Buell R., (LTC) (M60) 112 N. Jacksonville St, White Hall, IL 62092. Res: (217) 374-2049. Svc: USA. Ret: 78. 26 yrs.

POWELL, Edwin L., Jr., (BG) (M57) (Spec) 1740 Long Green Drive, Annapolis, MD 21401. Res: (301) 757-5504. S: Cleo. Svc: USA. Ret: 71. 30 yrs. Past NEB. Past Pres.

POWELL, Ralph J., (COL) (M70) (Jack) 1 Covey Point Lane, Savannah, GA 31411. Res: (912) 598-8266. S: Julie. Svc: USA. Ret: 79. 32 yrs.

PRESTIPINO, Samuel A., (LTC) (M72) (Sam) P.O. Box 515, Canyon Creek, MI 59633. Dy: (406) 444-6334. Res: (406) 449-4826. S: Margale R. Job: Compliance Officer, MT Dept of Health. Ret: 83. 23 yrs.

PRESTON, Wilmar L., (LTC) (M80) 4427 N. 53 Lane, No. 1, Phoenix, AZ 85031. S: Jo Ann. Svc: USA. Ret: 70. 26 yrs.

PRICE, Lucius D., (CW4) (M67) 7445 East 69th Terrace, Kansas City MO 64138. Res: (816) 966-8478. S: Lella. Job: Commercial ASEL. Svc: USA. Ret: 80. 35 yrs.

PRICE, Robert D., (LTC) (M78) (Bob) 201 Wild Oak Drive, Brandon, FL 33511. Res: (813) 685-2998. S: Gunn. Svc: USA. Ret: 81. 24 yrs.

PRIDDY, Bennie, (CW3) (M70) (Ben) Crawford Technical Svc, Campbell Aa, P.O. Box 2037, Fort Campbell, KY 42223. Res: (502) 439-1393. Job: Mgr, Airfield Swcs Campbell Army Airfield. Svc: USA. Ret: 85. 25 yrs.

PROCTOR, James H., (LTC) (M58) (Jim) 5808 Holton Lane, Temple Hills, MD 20748. Dy: (301) 981-5181. Res: (301) 894-0414. S: Mildred. Job: Chf Army Field Offc, Hq AFSC, Andrews AFB. Svc: USA. Ret: 64. 22 yrs.

PULLANO, Joseph F., (MAJ) (M67) (Joe) 5356 E. Fairbrook Street, Mesa, AZ 85205. Dy: (602) 891-2590. Res: (602) 981-9939. S: Shirley. Job: Mgr, New Bus. Trng & Logis Svcs, McDonnell Douglas Hqtr. Svc: USA. Ret: 81. 20 yrs.

PULLIAM, Nathan M., (COL) (M61) (Nate) 40 Deerfield Road, Covington, GA 30029. Dy: (404) 463-1234. Res: (404) 787-1742. S: Janet. Job: Assoc Broker, Premier Brokers Real Estate. Ret: 81. 32 yrs. Past Pres, Rhine Valley Chapter.

PUMPHREY, A.T., (COL) (M57) (Pump) 524 Genesee Road, San Antonio, TX 78209. Res: (512) 829-6555. S: Angela. Svc: USA. Ret: 73. 33 yrs. Past Pres, Phantom Corps Chapter. HOF.

PUTNAM, George W. Jr., (MG) (M59) 5505 Seminary Rd Apt 505N, Falls Church, VA 22041. Res: (703) 379-0026. S: Claudine. Svc: USA. Ret: 81. Past NEB. HOF.

QQQQQ - RRRRR

QUALE, Orvin, (MSG) (M87) 1436 Howard Ave, Eau Claire, WI 54703. Res: (715) 834-4653. S: Lois. Svc: USA. Ret: 53. 7 yrs.

QUATTLEBAUM, Harold D., (CW4) (M64) (Bob) Route 1, Box 155, Arlton, AL 36311. Dy: (205) 393-1769. Res: (205) 762-2217. S: Frances. Job: Contract Instr, Pilot, USAAVNS. Svc: USA. USAF. Ret: 74. 26 yrs.

QUEEN, Bernard B., (COL) (M59) (Bernie) 112 Glensages Drive, Nicville, FL 32578. Dy: (205) 263-0043. Res: (904) 897-4065. S: Barbara. Job: European Rep, Al Econ Dev Offc. Svc: USA. Ret: 84. 31 yrs.

QUESENBERRY, John R., (LTC) (M77) (Quiz) 6627 Edmonton Avenue, San Diego, CA 92122. Dy: (619) 546-4820. Res: (619) 457-1193. S: Heidi. Job: Wstrn Reg Rep, SPECO Corp. Svc:

R The SPOOF Roster

USA. Ret: 85. 23 yrs.

QUINLAN, James A., (COL) (M57) 1807 NW 32nd Street, Lawton, OK 73505. Dy: (405) 355-9280. Res: (405) 248-8629. S: Nettie. Job: Branch Mgr, Telos Federal Sys. Svc: USA. Ret: 80. 26 yrs. Past Sec.

RACKLEY, Robert L., (LTC) (M60) (Bob) 2700 Garth Rd, Se, Huntsville, AL 35801. Dy: (205) 882-6050. Res: (205) 882-9713. S: Barbara. Job: Mlg Rep, R.W. Mitscher Co., Inc. Svc: USA. Ret: 79. 20 yrs.

RADSPINNER, Frank H., (LTC) (M57) 816 Sylvan Drive, Fort Worth, TX 76112. Dy: (817) 260-3724. Res: (817) 461-0077. S: Diana. Job: Reg Mgr, Europe, Bell Hqtr. Ret: 76. 21 yrs. Past VP.

RADWICK, Michael J., (MAJ) (M67) (Mike) 116 S. Main St, Enterprise, AL 36330. Dy: (205) 393-2634. Res: (205) 393-2035. Job: Owner, The Lobby Restaurant & Lounge. Svc: USA. Ret: 86. 21 yrs.

RAGSDALE, Jack D., Jr., (LTC) (M73) (Jack) 1171 Heatherwood Court, Marietta, GA 30062. Dy: (404) 261-5400. Res: (404) 973-9499. S: Brenda. Job: Dir of Ticket Opns, Atlanta Falcons. Ret: 84. 21 yrs. Past Sr VP, Fort Bragg Chapter.

RALEY, Royce D., (CW4) (M58) P.O. Box 435, Dawson, TX 76639. Dy: (817) 578-1206. Res: (817) 578-1073. Job: EMT, Dawson Vol Amb. Svc: USA. Ret: 71. 21 yrs.

RAMAGE, Gary F., (LTC) (M63) 7409 Forest Hunt Ct, Springfield, VA 22153. Dy: (703) 920-4220. Res: (703) 440-0103. S: Margie. Job: Mgr, Govt, Ret, Augusta Avn Corp. Svc: USA. Ret: 86. 25 yrs. 66 McClellan.

RAMSEY, Bobby A., (COL) (M59) (Bob) 501 Stillwaters Drive, Marietta, GA 30064. Dy: (202) 955-3453. Res: (703) 329-0121. S: Harriet. Job: Dir, Int'l Programs, Lockheed. Svc: USA. Ret: 81. 26 yrs.

RANKIN, Alexander J., (COL) (M57) (Alec) 16003 Edgewood Drive, Dumfries, VA 22026. Dy: (202) 265-8720. Res: (703) 670-8882. S: Helene. Job: Dir, Hqtr Opns, Editor, Newsletter, Proc NAA, Wash, DC. Svc: USA. Ret: 65. 25 yrs. Past NEB. Past Pres, Bonn Area Chapter.

RANKIN, Thomas C., (LTC) (M62) (Tom) 1359 Brandwyne Lane, St Charles, MO 63303. Dy: (314) 645-1113. Res: (314) 447-6516. S: Marie. Job: Sr Engr, ARINC Research Corp. Svc: USA. Ret: 82. 23 yrs.

RATCLIFF, Walter A., (COL) (M59) (Walt) 88 Townhouse Lane, Corpus Christi, TX 78412. Dy: (512) 881-5321. Res: (512) 993-1168. S: Jo Gene. Job: VP Corp Svcs, Cntrl Power & Light Co. Svc: USA. Ret: 81. 28 yrs. Past Pres, Lindbergh Chapter.

RATHBONE, William A., (COL) (M58) (Bill) Apartado 1524, Cuernavaca, Morelos, 62000 Mexico. Dy: (527) 314-2050. Res: (527) 314-2050. S: Janet. Job: Attorney-At-Law. Svc: USA. Ret: 75. 26 yrs. Past VP, Washington DC Chapter.

RAWLINGS, Morris G., (LTC) (M59) (Ris) 59 Millwright Drive, Old Mill Manor, Newark, DE 19711. Res: (302) 738-7744. S: Jean. Job:

CEO, Rawlings Assoc. Svc: USA. Ret: 65. 23 yrs. Past Sec, Delaware Valley Chapter.

REED, Frank A., (MR.) (M82) P.O. Box 656, Lake Ozark, MO 65049. Dy: (314) 365-4581. Res: (314) 392-3141. S: Roselyne. Job: VP, Avcon Corp. Svc: USA.

REEDER, John J., (LTC) (M68) 1843 E. 153rd Circle, Olathe, KS 66062-2956. Res: (913) 782-8133.

REESE, John B., (LTC) (M58) 2548 Hwy 297 A, Cantonment, FL 32533-7633. Res: (904) 968-0126. S: Anne. Job: Dir of Pers Trng, Maritime Corp, Pensacola. Svc: USA. Ret: 73. 24 yrs.

REID, Robert W., (LTC) (M58) (Bob) Box R-125, APO New York 09102. Res: FRG (06227) 61754. S: Helga. Ret: 69. 21 yrs.

REINSHAGEN, Thomas E., (MAJ) (M71) 89 St Croix Drive, Newport News, VA 23602. Res: (804) 874-2406. S: Rita. Job: Logistics Mgr, Fort Eustis, VA. Svc: USA. Ret: 80. 20 yrs.

RESTIVO, Charles J., (CW4) (M61) (Chuck) 460 Bradley Avenue, Ne, Palm Bay, FL 32907. Dy: (407) 858-4143. Res: (407) 725-6061. S: Dotlie. Job: Chief Pilot, Faith Flight I. Svc: USA. Ret: 85. 21 yrs.

REUTHER, Ronald, (LTC) (M86) (Ron) 1014 Delaware Street, Berkeley, CA 94710. Dy: (415) 644-8031. Res: (415) 644-8031. Job: Distrib., City Schls, Inc. Svc: USA, USAF. Ret: 81. 30 yrs.

REYNOLDS, Charles W., (MR.) (M60) (Charley) 10059 Denness, St Louis, MO 63137. Res: (314) 868-0651. S: Peggy. Svc: USA, USN. 42 yrs.

REYNOLDS, Robert S., (LTC) (M62) (Bob) 91 Gleason Road, Lexington, MA 02173. Dy: (617) 229-5187. Res: (617) 861-9712. S: Gayle. Job: Engrng Scientist, GE Automated Systems Dept. Svc: USA. Ret: 81. 20 yrs.

RICHARDS, David A., (COL) (M58) 5216 Grantham Street, Springfield, VA 22151. Res: (703) 978-1296. S: Joan. Svc: USA. Ret: 78. 30 yrs.

RICHARDS, Robert E., (MAJ) (M61) (Bob) 11961 Paseo Bonita, Los Alamitos, CA 90720. Dy: (213) 549-9170. Res: (213) 430-0297. S: Jean. Job: Sales Rep, Sunset RV, Carson, CA. Svc: USA. Ret: 74. 22 yrs.

RIOS, Jose R., (CW3) (M58) Z-5 Yagrumo, Valle Arriba Heights, Carolina, PR 00630. Res: (809) 769-1409. S: Christy. Svc: USA. Ret: 79. 20 yrs.

RIVERA, Felix Jr., (CW4) (M64) 1305 Nile Drive, Corpus Christi, TX 78412. Res: (512) 991-7606. S: Doris. Svc: USA. Ret: 77. 24 yrs. Past Sr VP, Monterey Bay Chapter.

ROBERTS, Tommy R., (CSM) (M85) (T.R.) 1815 Camilla Road, Fort Hood, TX 76541. Dy: (817) 288-3029. Res: (817) 634-2869. S: Mleko. Job: Quality Control, Lockheed. Svc: USAF. Ret: 87. 30 yrs. Past VP, Phantom Corps Chapter.

ROBINSON, Charles A., (LTC) (M60) (Tony) 529 Main Street, P.O. Box 1006, W. Newbury, MA 01985. Dy: (508) 870-4121. Res: (508) 363-2294. S: Mary. Job: Software Cntrl Mgr, GTE Govt Sys Corp. Svc: USA. Ret: 79. 21 yrs. Past Pres, Leavenworth Chapter.

ROBINSON, Edward C., (COL) (M50) (Ed) 7603 Hayfield Road, Alexandria, VA 22310. Dy: (703) 685-3453. Res: (703) 971-2010. S: Patricia. Job: Sr Def Analyst, ANSER. Svc: USA. Ret:

83. 24 yrs.

ROBINSON, James E., (COL) (M61) (Jim) 18546 Prince William Lane, Houston, TX 77058. Dy: (713) 293-3963. Res: (713) 333-5291. S: Daria. Svc: USA. Ret: 84.

ROCKEY, James D., (COL) (M59) (Jim) 2234 Candlewood Drive, Alexandria, VA 22308. Dy: (703) 875-3959. Res: (703) 690-4432. S: Deanie. Job: Consultant, JDR, Inc.; Realtor, Thomas Realty, Inc. Svc: USA. Ret: 85. 30 yrs. Past Pres, Colonial Virginia Chapter.

ROEDER, Helmut A., (DR.) (M58) (Hal) 801 R. APO NY 09080. Dy: 01149-2268 (6-16) Box 1. Res: 01149-228-85-65-65. Job: Mgr, Hcpr Pgms Europe, McDonnell Douglas Hcpr Co. Svc: USA. Ret: 82. 27 yrs. Sec, Bonn Area Chapter. Past Pres, Bonn Area Chapter.

ROGERS, Homer C., (CW3) (M87) 292 Heck Road, Kenesaw, GA 30144. Dy: (404) 926-7994. Res: (404) 926-7994. S: Norma. Ret: 75. 19 yrs.

ROGERS, R. Joe, (COL) (M66) (Joe) Route 2, Box 214, Woodstock, VA 22664. Dy: (703) 264-3700. Res: (703) 459-5439. S: Jean. Job: Asst VP/IMG NE Fld Ofc, United Svs, Auto Assn. Svc: USA. Ret: 76. 25 yrs.

ROLLINGER, Jack R., (COL) (M63) 3420 Maryland Street, Alexandria VA 22309. Res: (703) 360-3481. S: Carolyn. Svc: USA. Ret: 83. 30 yrs.

ROLLINS, Donald L., (CW4) (M80) P.O. Box 29236, Shreveport, LA 71149-9236. Dy: (318) 632-5657. Res: (318) 686-4710. S: Karen. Job: Senior Erg Test Pilot, Rockwell International. Svc: USA. Ret: 88. 20 yrs.

ROOP, Troy J., (MAJ) (M84) (Jim) 4224 River Bluff Drive, Ft. Wayne, IN 46815. Dy: (219) 429-6494. Res: (219) 466-3077. S: Linda. Job: Dir., Mktg., Magnavox. Svc: USA. Ret: 82. 20 yrs.

ROPP, Richard F., (COL) (M58) (Dick) Honeywell G.S.F.M. 11842 Borman Drive, St. Louis, MO 63146-4087. Dy: (314) 569-7603. Res: (314) 837-2606. S: Sara. Job: Mkt Dev Mgr, Honeywell, Inc. Svc: USA. Ret: 84. 29 yrs.

ROSE, Jean L., (CSM) (M84) 30 Archville Drive, Belleville, IL 62221. Res: (618) 235-6305. S: Gale. Svc: USA. Past VP, Mid-America Chapter.

ROSS, Marlen C., (LTG) (M82) (Collier) 1958 Chardridge Court, Dumwoody, GA 30038. Dy: (404) 394-2548. Res: (404) 391-9861. S: Ann. Job: Exec VP, Sidwell-Ross & Assoc., Inc. Svc: USA. Ret: 83. 39 yrs.

ROVETTO, John L., (CW4) (M58) Route 4-box 4371, Belton TX 76513. Dy: (817) 939-1851. Res: (817) 939-5659. S: Jo. Job: Chf Pilot, Odell Fire Construction, Inc. Ret: 75. 22 yrs. Past VP, Mount Rainier Chapter.

RUNK, Adam E., (MAJ) (M63) 200 Sunrise Avenue, Satellite Beach, FL 32937. Dy: (407) 853-5485. Res: (407) 773-0421. S: Sandra. Job: Foreman, Shops & Utilities, Pan Am World Svc, Inc. Svc: USA. Ret: 74. 21 yrs. Past VP, Northern Lights Chapter.

RUNNELS, W.L., (LTC) (M87) Rt 4, 17 Summer Place, Hattiesburg, MS 39402. Res: (601) 264-4903. S: Naomi. Svc: USA. Ret: 68. 20 yrs.

RUSK, Richard A., (DR) (M57) (Dick) USS-ISM, USMCA-Munich, APO New York 09407. Dy: (089) 690-2420. Res: (089) 690-8094. S:

R The SPOOF Roster

Ltr. Job: Associate Professor, USC. Svc: USA. Ret: 68. 20 yrs. Charter Member.

RUSSELL, Jerry W., (LTC) (M74) Shape - CISDP/PCB, APO NY 09055. Dy: (065) 44-4984 (Belgium). Res: (065) 72-8363 (Belgium). S: Joanne. Job: Admin Ofcr, Manpower, North Atlantic Treaty Org. (At Shape). Svc: USA. Ret: 87. 27 yrs.

RUTH, Francis J., (CW3) (M58) (Joe) Route 1, Box 95, Kittrell, NC 27544. Dy: (919) 492-0273. S: Alice. Job: Gentleman Farmer-Consultant, Poverty Ridge Group. Svc: USA, USN. Ret: 66. 25 yrs.

RUTKOWSKI, Joseph F., (COL) (M58) (Joe) 205 West Sandcreek Road, Enterprise, AL 36330. Dy: (205) 347-0581. Res: (205) 347-4966. S: Mary. Job: Exec Dir, Enterprise Chamber of Comm. Svc: USA. Ret: 83. 36 yrs. Past Pres, Army Avn Center Chapter.

RYAN, Patrick F., (MAJ) (M82) (Pat) 2426 Grande Avenue, Cedar Rapids, IA 52403-2818. Dy: (319) 395-8096. Res: (319) 366-6990. S: Chris. Job: Mgr, Contracts, Rockwell Int'l. Svc: USA. Ret: 82. 20 yrs.

RYCHLIK, Thaddeus F., (CW2) (M87) 1621 Pinehurst Dr. NE, Apt. 68, Cedar Rapids, IA 52402. Dy: (319) 395-4021. Res: (319) 395-9842. S: Victoria. Job: Electronic Eng, Rockwell Int'l. Svc: USA, USAF. Ret: 79. 20 yrs.

SSSSSSSSSS

SABEY, Walter D., (CW3) (M58) 280 Silver Bay Road, Toms River, NJ 08753-2447. Dy: (201) 544-4392. Res: (201) 255-3127. S: Dorothy. Job: Aroft Staff Specialist, Avionics. Svc: USA. Ret: 65. 21 yrs.

SABISTON, Thomas J., (LTC) (M57) (Tom) Curator, USA Avn Museum, Box 610, Fort Rucker, AL 36362. Dy: (205) 255-4507. Res: (205) 347-8115. S: Peggy. Job: Dir, US Army Avn Museum. Svc: USA. Ret: 60. 22 yrs. Past Sec, Army Avn Center Chapter.

SADOWSKI, Paul D., (CW4) (M74) 2436 Ashcake Road, Mechanicsville, VA 23111. Dy: (804) 786-5773. Res: (804) 746-4671. S: Pat. Job: Citation Cmd Pilot, Commonwealth of Va. Svc: USA. Ret: 81. 25 yrs. Past Tre, Washington DC Chapter.

SALCH, Joseph F., (LTC) (M57) (Joe) 1154 North Madeline St., New Braunfels, TX 78132-4724. Res: (512) 625-0625. S: Bobbie. Svc: USA. Ret: 71. 20 yrs.

SALISBURY, Gary Leo, (MAJ) (M87) Rt 1, Box 127, Mineral Wells, TX 76067. Dy: (817) 325-1321. Res: (817) 325-7370. S: Christa. Job: Gas Measurement Tech, SW Gas Pipeline Inc. Svc: USA. Ret: 76. 20 yrs.

SALM, John H. Jr., (LTC) (M58) 4569 E. Lafayette, Phoenix, AZ 85018. Dy: (602) 271-2379. S: Louise. Job: Snr Army Instructor, HSR0TC, Ctrl HS. Svc: USA. Ret: 72. 20 yrs.

SALMON, Ray W., (COL) (M59) 5102 Risada Street, San Antonio, TX 78233-5912. Res: (512) 663-5797. S: Sue. Job: Pharmacist. Svc: USA. Ret: 86. 32 yrs. Past Pres, Jack H. Dibrell/Alamo/.

SAMUELS, Charles W., (LTC) (M85) (Charlie) 704 S. Illinois Ave, Suite C-103, Oak Ridge,

TN 37830. Dy: (615) 482-0064. Res: (615) 482-3502. S: Roseanne. Job: Sr Logistical Pvm Analyst, Science & Technology, Inc. Svc: USA. Ret: 87. 23 yrs.

SANDERS, Bobby J., (LTC) (M63) (Bob) Route 1, Box 228-d, Piney Flats, TN 37686. Dy: (615) 764-1122. Res: (615) 538-8528. S: Marjorie. Job: Facilities Supvr, Raytheon Co. Svc: USA. Ret: 79. 27 yrs. Past VP.

SANDERS, Burnett R., (COL) (M58) (Bud) 2600 Riedling Drive, Louisville, KY 40206-1413. Res: (502) 697-5850. S: Emily. Svc: USA. Ret: 86. 30 yrs. Past Sr VP, Thunderhorse Chapter.

SANDIDGE, Charles R., (LTC) (M57) 5618 Entiat River Road, Entiat, WA 98822. Res: (509) 784-1772. S: Teresa. Job: Owner, Sanray Orchards. Svc: USA. Past Sr VP, Mainz Chapter.

SANDIDGE, Johnnie R., (CW4) (M73) 546 Johnson Drive, Duncanville, TX 75116. Dy: (214) 247-7115. Res: (214) 296-4479. S: Madge. Job: Mgr, Sandidge Svc Co., Dallas. Svc: USA. Ret: 77. 32 yrs. HOF.

SANDRIDGE, James W., Jr., (COL) (M61) (Jim) 10305 Sandpiper Road W, Bradenton, FL 34209. Res: (813) 794-3426. S: Eula. Ret: 71. 30 yrs.

SARKO, John S., (LTC) (M57) 708 Judith Court, West Bend, WI 53095. Svc: USA. Ret: 77. 39 yrs.

SARNECKI, Aloysius P., (COL) (M63) (Al) 15453 North 30th Drive, Phoenix, AZ 85023. Dy: (602) 925-7360. Res: (602) 863-3034. S: Ruth. Job: Eng Section Hd, Local Fed Systems. Svc: USA. Ret: 79. 20 yrs.

SAUTMAN, John D., (MR) (M87) (Don) 224 Eastern, Greenville, IL 62246. Dy: (618) 259-7763. Res: (618) 664-1900. S: Della. Job: Facility Mgr, Amer Elec Lab - Stl Reg A/P. Svc: USA, USN. Ret: 57. 35 yrs.

SAWYER, Francis A., (LTC) (M88) (Frank) 5917 Cherry Street, Kansas City, MO 64110. Dy: (816) 333-2197. Res: (816) 333-2197. S: Dawn. Job: Attorney. Svc: USA. Ret: 70. 20 yrs.

SCANLAN, William H., (LTC) (M59) (Bill) 30 Bray Wood Road, Williamsburg, VA 23185. Dy: (804) 877-3770. Res: (804) 229-7713. S: Christiane. Job: Chiropractic Physician, Denbigh Chiropractic Clinic. Svc: USA, USN, USMC. Ret: 76. 27 yrs.

SCHAUMBERG, Thomas J., (LTC) (M67) (Tom) 2048 Brady Creek Circle, Sandy, UT 84092. Dy: (801) 263-9393. Res: (801) 943-9989. S: Christa. Job: Pres, Fortness Financial & Pension Services, Inc. Ret: 83. 26 yrs.

SCHELHORN, Carlton L., (LTC) (M61) (Shady) 1912 Stirrup Lane, Alexandria, VA 22308. Dy: (703) 941-8384. Res: (703) 780-4633. S: Pat. Job: Dir, Potomac Research, Inc. Svc: USA. Ret: 78. 24 yrs.

SCHRAMM, Walter J., (CW4) (M59) Box R 38, APO New York 09165. Dy: 6007-1032. Res: 6181-259479. S: Ingrid. Job: Ops Mgr, Rotorflug, Svc, Friedrichs Dorf, Frg. Svc: USA. Ret: 74. 20 yrs.

SCHRUM, James R., (LTC) (M61) (Jim) 11824 Clara Way, Fairfax Station, VA 22039. Dy: (703) 642-4717. Res: (703) 250-5541. S: Nancy Jean. Job: Contracts Mgr, Atlantic Research Corp. Ret: 80. 20 yrs.

SCHRYER, Malcolm S., (LTC) (M57) (Mal) 29

Dunham Road, Hartsdale, NY 10530. Dy: (914) 478-4000. Res: (914) 693-4422. S: Diane. Job: VP Warehousing & Traffic Svc Mgr Corp. Hastings-On-Hudson. Svc: USA. Ret: 72. 21 yrs.

SCHUETT, Darwin L., (LTC) (M58) (Dar) 2018 Linn, Boone, IA 50036. Dy: (515) 432-5221. Res: (515) 432-8009. S: Elsie. Job: Sales, Gillespie Pontiac/Olds/Gmc. Svc: USA. Ret: 71. 24 yrs.

SCHULTE, Victor J., (LTC) (M58) (Vic) 7434 Kingsbury Blvd., St. Louis, MO 63130. Dy: (314) 895-3420. Res: (314) 862-0636. S: Job: Sr Pgm Mgr, FGA, Inc. & Real Estate. Svc: USA. Ret: 77. 23 yrs.

SCHWALL, Ronald R., (CW4) (M77) (Ron) 201 Wildwood Drive, Enterprise, AL 36330-1583. Dy: (205) 255-2188/2464. Res: (205) 393-4207. Job: DAC Trng Specialist, Avn Trng. Bge, USAFVAC. Svc: USA. Ret: 86. 20 yrs.

SCOTT, Charles M., Jr., (BG) (M79) (Red) P.O. Box 924, Litchfield Park, AZ 85340. Dy: (602) 863-8938. Res: (602) 935-4130. S: Myrna. Job: Dir, OEM Mktg, Honeywell-Sperry Flight Systems. Svc: USA. Ret: 88. 35 yrs.

SCOTT, Donald R., (MAJ) (M63) (Don, Scot) 2631 Cedric Circle, Lawton, OK 73505. Dy: (405) 353-0248. Res: (405) 355-7144. S: Cora Ann. Job: Owner, OK Legal Process Service. Svc: USA. Ret: 84. 23 yrs.

SCOTT, Engle W., (COL) (M61) 7440 Lochwood Court, Fort Worth, TX 76179. Dy: (817) 280-8079. Res: (817) 236-1986. S: Judith. Job: Mgr, V-22 Trng, Bell Hcptr Textron Inc. Svc: USA. Ret: 86. 26 yrs. Past Pres, Jack H. Dibrell/Alamo/.

SCOTT, Harold R., (CW4) (M59) (Scotty) 746 Crescent Drive, Reidsville, NC 27320. Res: (919) 349-4407. S: Rachel. Svc: USA. Ret: 70. 21 yrs.

SCOTT, Harry A. Jr., (COL) (M57) (Scotty) Route 1, Box 1935, Henderson, TN 38340. Res: (901) 989-3990. S: Ruth. Ret: 83. 35 yrs.

SEEFELDT, Richard S., (CW4) (M59) 411 Meadow Lane, Enterprise, AL 36330-1123. Dy: (205) 255-8107. Res: (205) 347-6772. S: Virginia. Job: Mgr, AVNDA, Dyncorp. Svc: USA. Ret: 82. 29 yrs. 80 AA of Yr.

SENEFF, George P. Jr., (LTG) (M57) (Philp) 2939 Hibiscus Place, Honolulu, HI 96815. Res: (808) 923-9598. S: Franki. Ret: 74. 39 yrs. Past NEB, HOF.

SERRATT, Jerry W., (LTC) (M62) (Horseth) 6516 Riviera Drive, Fort Worth, TX 76180. Dy: (817) 935-1052. Res: (817) 281-9263. S: Pat. Job: Engr Spec., Btd Integtrn Ctr, Gen. Dynamics. Svc: USA. Ret: 81. 20 yrs.

SEVIER, David W., (SGT) (M60) (Deacon) 2507 Chesterfield Drive, Fort Pierce, FL 34982. Res: (407) 464-5526. S: Frances. Svc: USA, USAF. 4 yrs.

SEXTON, Charles D., (LTC) (M74) (Dave) 320 Union Street, Aberdeen, MD 21001. Dy: (301) 278-2035. S: Jane. Job: Avn Safety Off, Hq TCOM. Svc: USA. Ret: 82. 21 yrs.

SHALLCROSS, George W., (COL) (M58) 9730 Sibley Circle, Orlando, FL 32819-6323. S: Audrey. Job: Gen Ins. Agent, Health Investors Svcs, Inc. Svc: USA. Ret: 80. 34 yrs.

SHANKLIN, David M., (CW4) (M57) (Dave) Route 5, Box 648, Mebane, NC 27302. Dy: (919) 732-2161. Res: (919) 563-4626. S: Pat.

S The SPOOF Roster

Job: Letter Carrier, U.S. Postal Service. Svc: USA. Ret: 74. 25 yrs.

SHARE, Louis L., (MAJ) (M57) (Lou) 201 Candy Drive, Enterprise, AL 36330. Dy: (205) 598-6121. Res: (205) 347-7606. S: Jean. Job: Hcptr Instr Pilot, Flight Safety Inst. Svc: USA. Ret: 72. 25 yrs. Past Sec, Morning Calm Chapter.

SHARER, John W., (CW4) (M81) Box 145, APO NY 09056. Res: FRG 06202-61076. S: Sandra. Job: Techdyn Systems Corp, Mgmt Specialist. Svc: USA. Ret: 87. 21 yrs. Past Sr VP, Schwaebisch Hall Chapter.

SHARP, Leonard J., (LTC) (M60) 101 Kentucky Street, Enterprise, AL 36330. Res: (205) 347-3027. S: Juanita. Svc: USA. Ret: 74. 25 yrs.

SHAYER, Thomas J., (LTC) (M68) USMCA-P Box 251, APO NY 09189. Dy: 011-49-6331-86-6506. Res: 011-49-6395-7763. S: Darlyn. Job: Community Exec Off, Pirmassens Mil Cmty, US Army. DAC. Svc: USA. Ret: 85. 20 yrs. Past Sec, Suncoast Chapter.

SHAW, Ambrose C., (COL) (M57) 1350 Lee St., Arkadelphia, AR 71923. Res: (501) 246-7298. S: Ann. Svc: USA, USAF. Ret: 70. 28 yrs.

SHEA, Gerald H., (COL) (M57) (Gerry) 7244 Swan Lake Drive, Fort Myers, FL 33907. Res: (813) 481-4440. S: Sara. Svc: USA. Ret: 72. 30 yrs. Past Pres, Washington DC Chapter.

SHEELY, Raymond A., (MAJ) (M84) (Skipper) 555 Haholone Street, 14 H, Honolulu, HI 96825. Res: (808) 395-8898. Job: Pilot, Continental Airlines. Svc: USA. Ret: 85. 24 yrs.

SHEPARD, Claude L. Jr., (COL) (M57) (Shep) 50 Main Street, Northfield, MA 01360. Dy: (413) 545-0021. Res: (413) 498-2076. S: Jean. Job: Staff Assoc, U of MA. Svc: USA. Ret: 69. 30 yrs. HOF.

SHEPPARD, Orval H., (COL) (M58) (Shep) 108 Brentwood Plaza, Enterprise, AL 36330. Res: (205) 347-7744. S: Erma. Svc: USA. Ret: 71. 26 yrs. Past Pres, Follow Me Chapter.

SHERBINO, Vercy L., (CW3) (M69) (Sonny) Jl Budi Sari Vi 12A, Bandung, Indonesia. Dy: 62/22-613605. Res: 62/22-85924. S: Joyce. Job: Sr Prod Assur Engr, NB412 Pgm, Bell Hcptr, Textron. Svc: USA. Ret: 82. 22 yrs.

SHERMAN, Robert, (COL) (M74) (Bob) American Embassy, Box 145, APO New York 09080. Dy: (228) 036-3006. Res: (228) 034-9795. S: Edliraud. Job: VP, Martin Marietta Int Inc. Svc: USA. Ret: 74. 30 yrs. Trea, Bonn Area Chapter. Past Trea, Bonn Area Chapter.

SHIELDS, George D., (COL) (M58) P.O. Box 154, Tolovana Park, OR 97145. Dy: (503) 436-1171. Res: (503) 436-2368. S: Sue. Job: Real Estate, Kent Price Realty, Cannon Beach. Svc: USA. Ret: 76. 25 yrs.

SHIELDS, Roger J., (COL) (M68) 17715 Gulf Blvd, No. 1109, Redington Shores, FL 33708. Dy: (703) 347-9118. Res: (813) 392-8800. S: Joan. Job: VP, Osprey Int'l Ltd. Svc: USA. Ret: 77. 25 yrs.

SHIRILLA, George, (LTC) (M82) (George) 112 Fox Hunt Court, Fayetteville, GA 30214. Dy: (404) 761-8136. S: Louise. Job: Filter Services, Inc., Mktg Rep. Svc: USA. Ret: 87. 20 yrs. Past

VP, Morning Calm Chapter.

SHIVELEY, Harry T., (LTC) (M57) (Shive) 910 Westwood Drive, N.E., Vienna, VA 22180. Dy: (703) 521-6560. Res: (703) 281-4080. S: Donna. Job: Consultant, LTV Missiles & Defense. Svc: USA. Ret: 60. 20 yrs. Past VP, Washington DC Chapter.

SHIVELY, Jawarren B., (MAJ) (M58) (Joe) 2951 Industrial Road, No. 54, Las Vegas, NV 89109. Dy: (702) 457-3782. Res: (702) 457-3782. Svc: USA. Ret: 65. 20 yrs.

SHOEMAKER, Robert M., (GEN) (M60) (Bob) Box 4510-K, Route 4, Belmont, TX 78513. Dy: (800) 234-2740. Res: (817) 698-3201. S: Tuke. Job: City Commissioner, Precinct 2, Bell County. Svc: USA. Ret: 82. 36 yrs. HOF.

SHONER, George D., (LTC) (M60) 1000 Camerlon Drive, 6119, Harding, TX 78550. Res: (512) 423-8341. S: Edith. Svc: USA. Ret: 58. 23 yrs. Past VP, Lindbergh Chapter.

SHORE, Edward R. Jr., (COL) (M62) (Ed) P.O. Box 2122, Woodbridge, VA 22193. Dy: (703) 670-6101. Res: (703) 690-1927. Job: Assoc Broker, Coldwell Banker, Res Real Est Svc. Svc: USA. Ret: 80. 26 yrs.

SHOULTS, William E., (MAJ) (M67) (Dutch) 111 Emerald Drive, Enterprise, AL 36330. Dy: (205) 794-3872. Res: (205) 347-3517. S: Sheila. Job: Sikorsky Aircraft, Dothan. Svc: USA. Ret: 80. 22 yrs.

SHROYER, Raymond, (1SG) (M80) 4735 Fairview Downers Grove, IL 60515. Dy: (815) 672-2093. Res: (312) 969-1144. S: Diane. Past VP.

SIBERT, Daniel S., (CW4) (M67) (Dan) 13415 Yakima Road, Apple Valley, CA 92308. Dy: (619) 386-5074. Job: OS&H Specialist, NTC City Ofc. Svc: USA. Ret: 83. 22 yrs.

SIBERT, George W., (COL) (M59) (George) 3536 North 36th Road, Arlington, VA 22207. Dy: (202) 737-1010. Res: (703) 525-4094. S: Judith C. Job: Rolls-Royce. Svc: USA. Ret: 85. 26 yrs.

SIEGLING, Wm. A. Jr., (LTC) (M64) (Al) 5345 Mallard Drive, Pleasanton, CA 94566. Res: (415) 466-3135. S: Joyce. Job: Dept of Corrections, Santa Clara County. Ret: 87. 28 yrs.

SIGMAN, Herbert M., (MR) (M82) (Herb) 724 Lilac Avenue, Webster Groves, MO 63119. Res: (314) 961-6756. S: Helen. Svc: USA. Ret: 84.

SILVA, Warren R., (LTC) (M67) 2 Norseman Avenue, Gloucester, MA 01930. Dy: (508) 750-2820. Res: (508) 281-1264. S: Judy. Job: Dir Ft Ops, GTE Svc Corp. Svc: USA. Ret: 79. 21 yrs.

SILVER, Benjamin S., (COL) (M87) 123 N 30th, Gatesville, TX 76828. Dy: (817) 865-5473. S: Frances. Svc: USA. Ret: 74. 32 yrs.

SIMPSON, Jack C., (MR) (M76) (Jack) 10 Hanson Drive, Granite City, IL 62040. Res: (618) 797-0639. S: Connie. Svc: USA. Ret: 83.

SIMS, James S., (CW4) (M72) 8515 46th Ct N.E., Olympia, WA 98506. Dy: (206) 456-6771. Res: (206) 593-2165. S: Marlies. Job: Stry Ed Rep, Dept of Labor & Indus. Svc: USA. Ret: 84. 24 yrs.

SIMS, Wesley H., (LTC) (M59) (Wes) 1090 2nd Street, Box 728, Mukilteo, WA 98275. Dy: (206) 543-8200. Res: (206) 353-9133. S: Sally. Job: Computer Consultant, U of Wash. Svc: USA. Ret: 79. 22 yrs. Past Pres.

SINGLEY, George T. Jr., (LTC) (M57) 116 Lake Drive-Lakewood, Williamsburg, VA 23185. S: Gene. GS: 15. Svc: USA. Ret: 65. 23 yrs. Past VP, Colonial Virginia Chapter.

SLATTERY, John M., (LTC) (M68) (Slats) Helicopter Archive, P.O. Box 18029, Oxon Hill, MD 20745. Res: (301) 567-4407. S: Jane. Job: Hqtr Historian, Hqtr Archive. Svc: USAF, USMC. Ret: 74. 29 yrs.

SLOTT, Charles A., (LTC) (M58) (Charlie) 101 South Florence Avenue, Litchfield Park, AZ 85340. Res: (602) 935-3331. S: Dorothy. Svc: USA. Ret: 64. 23 yrs.

SLYE, Kenneth M., (MAJ) (M58) (Ken) 316 N. Howard St., No 403, Alexandria, VA 22304. Dy: (202) 697-7475. Res: (703) 370-1802. Job: Prog Analyst, Office of Sec of Defense. Svc: USA. Ret: 74. 20 yrs.

SMALL, Harold I., (MG) (M57) (Hank) 8215 Chancery Court, Alexandria, VA 22308. Dy: (703) 875-2812. S: Shirley. Job: Pres. H&S Assoc. Ret: 86. 37 yrs. Past Pres, Suncoast Chapter.

SMITH, Alan M., (LTC) (M69) (Alan) 445 Summit Club Drive, Marietta, GA 30068. Dy: (404) 256-3355. Res: (404) 971-9435. S: Betsy. Job: Stockbroker, Dean Witter Reynolds Inc. Svc: USA. Ret: 86. 20 yrs.

SMITH, Albert L., (LTC) (M54) (Al) 1112 Strathmore Avenue, Dothan, AL 36303. Dy: (205) 677-4750. Res: (205) 792-0664. S: Marilyn. Job: Veterans Svc Off, Houston County. Svc: USA. Ret: 76. 25 yrs.

SMITH, Blair E., (LTC) (M57) (P.O. Box 2265, Newport News, VA 23602. Dy: (804) 874-2545. Res: (804) 877-7801. S: Libby. Job: Broker & Property Mgr, ERA Libby Bloxom, Inc., Realtors. Svc: USA. Ret: 73. 21 yrs.

SMITH, Donald H., (COL) (M60) (Smitty) 7041 Bridgeport Circle, Stockton, CA 95207. Dy: (209) 944-8441. Res: (209) 952-8468. S: Patricia. Job: Asst Dir Emergency Services. Ret: 84. 28 yrs.

SMITH, Duane N., (COL) (M63) 16462 North Aspen, Fountain Hills, AZ 85268. Dy: (602) 891-5364. Res: (602) 837-8516. S: Janice. Job: McDonnell Douglas Hqtr Co. Svc: USA. Ret: 86. 27 yrs. Past Treas, Leavenworth Chapter.

SMITH, Herbert M., (LTC) (M58) 249 Firestone Drive, Roseville, CA 95678. Dy: (916) 786-2751. Res: (916) 782-3603. S: Thelma. Job: Weekend Mgr & Admin Asst, Park Roseville Retirement Comm. Svc: USA. Ret: 78. 27 yrs.

SMITH, James C., (MG) (M57) (Jim) 6037 21st Avenue, North, St. Petersburg, FL 33710. Dy: (703) 845-2476. Res: (813) 343-1148. S: Doris. Job: Institute For Defense Analysis. Svc: USA. Ret: 81. 39 yrs. NEB. Past Sr VP, Suncoast Chapter. HOF.

SMITH, Jimmy B., (LTC) (M82) (Jimmy) 1848 S. Los Alamos, Mesa, AZ 85204. Dy: (602) 231-1049. Res: (602) 926-8060. S: Judy. Job: ILS Mgr, Allied-Signal Aerospace Co, Garrett Engine Div. Svc: USA. Ret: 87. 33 yrs.

SMITH, Joe L., (LTC) (M62) 102 Oak Avenue, Enterprise, AL 36330. Res: (205) 347-7130. S: June. Svc: USA. Ret: 71. 20 yrs.

SMITH, Joseph P., (COL) (M58) (Pat) 218-A Lakeshore Drive, Whispering Pines NC 28327. Dy: (919) 949-3064. S: Lorette. Svc: USA. Ret: 70. 29 yrs.

S The SPOOF Roster

SMITH, Leo C. Jr., (COL) (M63) (Lee) P.O. Box 336, Daleville, AL 36322. Dy: (205) 598-9200. Res: (205) 393-3028. S: Sissy. Job: Fid Off Mgr, Boeing Hqtrs at Daleville/Ft Rucker. Svc: USA. Ret: 84. 26 yrs. Past Sec, Army Avn Center Chapter.

SMITH, Paul H., (CW4) (M73) 4832 16th Rd., N., Arlington, VA 22207. Dy: (202) 783-9006. Res: (703) 527-3825. Job: Mgr, ATC Svcs, Nat'l Bus. Aircft Assoc. Svc: USA, USAF. Ret: 85. 27 yrs.

SMITH, Richard A., (COL) (M60) (Smitty) 12696 Spring Creek Court, Moor Park, CA 93021. Dy: (818) 847-3375. Res: (805) 523-0613. S: Shirley. Job: Grp Eng, Lockheed Aeronautical Systems Co. Svc: USA. Ret: 85. 34 yrs. VP, Southern California Chapter. Past Sr VP, Lindbergh Chapter.

SMITH, Thomas G. Sr., (LTC) (M65) (Tom) 5624 Cambria Dr., Rockwall, TX 75087. Dy: (214) 457-6038. Res: (214) 771-4369. S: Diane. Job: Mgr Contracts, E-Systems Inc., Greenville Div. Svc: USA, USN. Ret: 84. 29 yrs.

SMITH, Wayne R., (MR) (M58) 2162-D Via Mariposa East, Laguna Hills, CA 92653. Dy: (714) 951-2276. Res: (714) 581-8465. S: Emma. Job: Starter, Laguna Hills Golf Course. Svc: USA. Ret: 80. 32 yrs. Past NEB. Past Pres, Lindbergh Chapter.

SMITH, William A., (LTC) (M59) (Bill) 4101 Park Drive, S.W., Olympia, WA 98502. Res: (206) 352-1047. Svc: USA. Ret: 70. 22 yrs.

SNYDER, Harold B. Jr., (COL) (M74) (Buz) 9900 Arrahatche Trail, Richmond, VA 23231. Dy: (804) 795-1446. Res: (804) 795-5876. S: Nelda. Svc: USA. Ret: 84. 28 yrs. Past Pres, Mount Rainier Chapter.

SNYDER, Harold R., (LTC) (M57) 510 Alexander St, Ennis, TX 75119. Res: (214) 875-7703. S: Marjorie. Ret: 62. 22 yrs.

SNYDER, Lawrence M., (CW3) (M80) (Larry) 6655 Dallas Drive, Florissant, MO 63033. Dy: (314) 532-4585. Res: (314) 355-0152. S: Frances. Job: Pilot, Metropolitan Hqtr, Inc. Svc: USA. Ret: 66. 21 yrs.

SNYDER, Orville H., (CPT/DAC) (M76) 1205 4th Avenue, Spring Lake, NJ 07762. Res: (201) 449-4326. S: Edna. Svc: USN. Ret: 86. 37 yrs.

SNYDER, Paul B., (COL) (M58) 1283 Granada Street, Upland, CA 91786. Dy: (714) 946-0929. S: Virginia. Svc: USA. Ret: 75. 26 yrs.

SNYDER, Robert F., (CW2) (M63) (Bob) 650 Crestway, San Antonio, TX 78239. Dy: (512) 221-5207. Res: (512) 657-4636. S: Cathy. Job: C, Mat Mvmts, Trans Div, Ft. Sam Houston, TX. Svc: USA. Ret: 68. 6 yrs.

SOUCEK, Leo E., (BG) (M58) Martin Marietta Corp., 6801 Rockledge Dr, Mo 323, Bethesda, MD 20817. Dy: (303) 897-6615. S: Evelyn Ann. Job: Dep Dir, AF Prog, Martin Marietta Corp. Svc: USA. Ret: 74. 25 yrs.

SOUTHERN, Ralph F., (CW4) (M72) 3732 Honeyuckle Court, Montgomery AL 36109. Dy: (205) 272-3433. Res: (205) 272-3463. S: Jessie. Job: Maint Dir, St Bede Church & School. Svc: USA. Ret: 79. 34 yrs.

SPEARS, Leroy C., (LTC) (M57) (Roy) Route

2, Box 361, Valley Head, AL 35989. Res: (205) 657-4069. S: Polly. Svc: USA. Ret: 64. 23 yrs.

SPEISER, Carl H., Jr., (MR) (M60) 9405 Eucalyptus Drive, Alton, MD 63123. Res: (314) 631-0782. S: Myrtle. Svc: USA. Ret: 84. 43 yrs.

SPIJKER, Donald J., (MR) (M64) 9121 Clarion Drive, St. Louis, MO 63136. Dy: (314) 867-1148. Res: (314) 867-1148. S: Mary. Job: Pres, Midstates Dynamics Sys Inc. Svc: USA.

STACY, John F., (LTC) (M58) 106 Country Club Hgts. Bl, Enterprise, AL 36330. Dy: (205) 347-5920. Job: Consultant. Svc: USA. Ret: 62. 22 yrs.

STACY, John M., (LTC) (M67) (Mike) 11685 Havenor Road, Fairfax Station, VA 22039. Dy: (202) 467-4092. Res: (703) 250-2449. S: Karen. Job: Dir, Advanced Unmanned Systems, Canadair, Inc. Svc: USA. Ret: 86. 20 yrs. Past Sec, Rhine Valley Chapter.

STANFIELD, John T., (COL) (M58) (John) 2636 Bent Hickory Circle, Longwood, FL 32779. Res: (305) 788-0407. S: Frances. Svc: USA. Ret: 73. 27 yrs. Past Pres, Delaware Valley Chapter.

STARZYK, Wm. F., Jr., (MSG) (M82) (Wild Bill) Rt. 1, Box 270, Hayes, VA 23072. Dy: (804) 878-3140. Res: (804) 642-9655. S: Karen. Job: Aft Armt Instr, Ft. Eustis. Svc: USA. Ret: 86. 21 yrs.

STEARNS, Robert D., (LTC) (M59) (Bob) 4736 Charing Cross Rd, Sarasota, FL 34241-6207. Res: (813) 377-9007. S: Joan. Svc: USA. Ret: 69. 22 yrs.

STECH, Richard J., (CW2) (M57) 1030 Hillview Drive, Lemont, IL 60439. Res: (312) 257-2765. S: Josephine. Svc: USA. Ret: 63. 20 yrs.

STEIN, Nicolas P., (MAJ) (M88) (Nick) 1 Cameron Lane, Savannah, GA 31411. Res: (912) 598-0717. S: Joan. Svc: USA. Ret: 72. 26 yrs.

STEINE, Joel R., (LTC) (M57) (Joe) 919 Catalina Drive, Newport News, VA 23602. Dy: (804) 874-7114. Res: (804) 874-5393. S: Judy. Job: Ar, Quality Assurance, Cobro Corp. Svc: USA. Ret: 81. 27 yrs.

STEVENS, Darryl M., (LTC) (M61) (Steve) Rt. 1, Box 17, Lonely Oak Lane, Killeen, TX 76541. Res: (817) 526-4053. S: Joan. Svc: USA. Ret: 78. 20 yrs.

STEVENS, Francis J., (MAJ) (M57) (Steve) 3202 Sue Ann, Wichita Falls TX 76309. Res: (817) 723-1571. S: Alice C. Svc: USA. Ret: 61. 20 yrs.

STEVENS, Jackson C., (MAJ) (M62) (Jack) Dept Of Mgt, Stetson Univ, Deland, FL 32720. Dy: (904) 734-4121. Job: Asst Prof, Stetson U. Svc: USA. Ret: 78. 24 yrs.

STEVENS, Jake H., (CW4) (M86) P.O. Box 1553, Enterprise, AL 36330. Dy: (205) 255-2480. Res: (205) 347-3579. S: Pam. Job: Ft Instr, Dept of the Army, DAC. Svc: USA. Ret: 81. 22 yrs.

STEVENS, Stacy C., (MG) (M57) (Sto) 1 Sally Port Road, Hilton Head, SC 29928. Res: (803) 681-8893. S: Sue. Job: Avn Consult'nt. Svc: USA. Ret: 83. 34 yrs. NEB.

STEWART, Thomas B., (COL) (M58) (Flaps) 2506 SE 14th Street, Mineral Wells, TX 76067. Res: (817) 325-7470. S: Ima Jean. Svc: USA. Ret: 70. 24 yrs.

STEWART, Edward A., (LTC) (M57) 7506 Huntleigh Lane, San Antonio, TX 78209. Svc:

USA. Ret: 69. 25 yrs. Past Pres, Jack H. Dibrell (Alamo).

STEWART, Harvey E., (COL) (M58) (Stew) 9 Greenbrier Lane, Oneonta, AL 35121. Res: (205) 625-3608. S: Travis. Svc: USA. Ret: 75. 28 yrs. Past VP.

STEWART, Jessie E., (COL) (M58) (Jess) P.O. Box 1884, Hartsville, SC 29550. Dy: (803) 363-3018. Res: (803) 332-4252. S: Freida. Job: City Mgr, Hartsville. Svc: USA. Ret: 83. 30 yrs. Past Pres, Fort Bragg Chapter.

STEWART, John P., (COL) (M59) 765 W. 30th Street, Carlisle, PA 17013. Res: (717) 249-8066. S: Mary. Job: Lecturer, PhD Candidate, Penn State Univ. Svc: USA. Ret: 85. 20 yrs.

STILES, Howard J., (COL) (M50) Rld 2, Box 2645, Deep Cove Shores Road, Raymond, ME 04071. Dy: (207) 892-6943. Res: (207) 855-4193. S: Ellen. Job: Owner/Broker, Vacationland Realty. Svc: USA. Ret: 83. 27 yrs. Past Pres, Fort Bragg Chapter.

STIPECH, Edward F., (LTC) (M58) (Ed) 2020 Stonewood Court, San Pedro, CA 90732. Dy: (213) 332-5760. Res: (213) 547-5565. S: Charlene. Job: QA Mgr, Cntl Fab, Tooling & Shipping, Northrop Aircraft Div. Svc: USA. Ret: 68. 22 yrs.

STOCKTON, Robert L., (COL) (M81) Box 3188, 824 North 18th Street, Waco, TX 76707. Dy: (817) 756-3767. Res: (817) 753-7656. S: Sylvia.

STOESSNER, Richard L., (COL) (M58) (Dick) 83 Coachman Circle, Newport News, VA 23602. Dy: (804) 838-4111. Res: (804) 874-8522. S: Beverly. Job: Govt Bus Coord, Sikorsky Acraft. Svc: USA. Ret: 80. 28 yrs. Past Pres, Colonial Virginia Chapter.

STONE, Howard F., (LTC) (M77) (Howie) 8501 Island View Court NE, Olympia, WA 98506. Res: (206) 357-3113. S: Helen. Job: Private Mgmt Consultant. Svc: USA. Ret: 85. 30 yrs.

STONE, Lawrence J., (LTC) (M58) 1420 Mapleview, S.E., Kentwood, MI 49508. Res: (616) 455-3138. Svc: USA. Ret: 79. 27 yrs.

STOOKEY, Frank T., (MAJ) (M77) 32003 42d Pl, Sw Federal Way, WA 98023. Dy: (206) 657-1148. Res: (206) 838-7277. S: Judith. Job: Contract Mgr, Boeing Aerospace. Svc: USA. Ret: 86. 25 yrs. Past VP, Mount Rainier Chapter.

STOWELL, James L., (MAJ) (M59) Route 2, Box 50-A, Rockingham, NC 28379. Dy: (919) 997-3945. Res: (919) 997-3945. S: Mae. Job: Gunsmith, "The Gunsmith". Svc: USA. Ret: 68. 20 yrs.

STRANGE, Loren C., Sr., (COL) (M58) (Carl) 407 Sherwood Drive, Maryville, TN 37801. Dy: (615) 984-2952. Res: (615) 984-2952. S: Mary Lynn. Job: President, TN Inova Corp. Svc: USA. Ret: 77. 30 yrs. Past Pres, Army Avn Center Chapter.

STRICKLAND, Stoney L., (LTC) (M59) (Sid) 9240 Garland Drive, Savannah, GA 31406. Dy: (912) 354-1011. Res: (912) 354-9588. S: Roselyn. Job: VP, Southside Fire Dept., USDA Milk Inspector. Svc: USA. Ret: 72. 25 yrs. VP, Coastal Empire Chapter. Past VP, Coastal Empire Chapter.

STROK, Michael J., (COL) (M57) (Mike) 37 Wileiner Drive, Edgewater, MD 21037. Res: (301) 266-8458. S: Marcia. Svc: USA, USAF. Ret: 67. 29 yrs.

S The SPOOF Roster

SULLIVAN, John F., (COL) (M57) 6736b E Cedar Avenue, Denver, CO 80224. Res: (303) 322-4072. S: Judith. Job: Sec-Treas, Kelley-Clarke Assoc, Inc. Svc: USA, USAF. Ret: 71. 32 yrs. Past Pres, Rhine Valley Chapter.

SULLIVAN, William F., (COL) (M58) 2211 Viewmont Way West, Seattle, WA 98199. Res: (206) 285-1798. S: Carol. Job: Alcohol & Drug Counselor, Care Unit. Svc: USA. Ret: 81. 28 yrs.

SULPIZI, James R., (COL) (M59) 42 Crisp Drive, New Castle, DE 19720. Res: (302) 328-1123. Past VP, Delaware Valley Chapter.

SUNDBY, Selmer A., (COL) (M57) (Sam) 119 Linda Drive, Newport News, VA 23602. Dy: (804) 874-6100. Res: (804) 874-6100. S: Peggy. Job: Consultant. Svc: USA. Ret: 74. 30 yrs. Past Sr VP, Colonial Virginia Chapter.

SWAN, John G., Jr., (MAJ) (M74) (Jack) Bendix/King Air Trans Div, 1165 S.W. 12th Road, Boca Raton, FL 33432. S: Lise. Job: Reg Mgr, Bendix/King Air Transport Div. Svc: USA. Ret: 73. 20 yrs.

SWEENEY, Edward J. Jr., (LTC) (M68) (Ed) 3690 Golfside Rd, Ypsilanti, MI 48197. Dy: (313) 226-6431. Res: (313) 572-1256. S: Ellen. Job: Contract Specialist, U.S. Army Corps of Engineers. Svc: USA. Ret: 87. 20 yrs.

SWEET, Richard S., (BG) (M84) (Dick) 402 Jasmine Court, Issue, MD 20645. Dy: (301) 870-4110. Res: (301) 259-4676. S: Meredith. Job: President, Sweet & Associates. Svc: USA. Ret: 78. 27 yrs.

SWEETMAN, James L., (COL) (M70) (Jim) 313 Flint Circle, Papillion, NE 68046. Dy: (402) 393-3884. Res: (402) 593-9106. S: Janet. Job: Omaha Regional Mgr, Interstate Insulation of America. Svc: USA, USAF. Ret: 85. 30 yrs. Past Pres.

SWENSSON, John K., (LTC) (M87) 14672 Wildberry Lane, Saratoga, CA 95070. Dy: (415) 948-9200. Res: (408) 741-5223. S: Barbara. Job: Belvoir Film Pro, Avn Films. Ret: 84. 24 yrs.

SWINDELL, Brennan R., (MR.) (M58) (Ray) Box 482, Dept. 14, Fort Worth, TX 76101. Dy: (817) 280-2268. Res: (817) 488-7789. S: Marty. Job: VP, Mill Bus Dev. Svc: USA. Ret: 75. 21 yrs. NEB. Past Pres, North Texas Chapter.

SWINK, Terry E., (LTC) (M73) 413 Elm Lane, Johnson City, TN 37804. Dy: (615) 461-1695. S: Vivian. Job: Snr Army Instr, Science Hill HS. Svc: USA. Ret: 87. 23 yrs.

TAJCHMAN, Robert E., (MR.) (M83) (Tom) 4206 Estate, Corpus Christi, TX 78412. Dy: (512) 939-3161. Res: (512) 852-5813. S: Cheryl A. Job: Overhaul/Aircraft Inspector, CCAAD.

TARKER, Alexander D., (MAJ) (M69) (Dave) 130 Scenic Drive, Madison, AL 35758. Dy: (205) 461-2593. Res: (205) 895-9016. Job: Sr Buyer, Boeing Mil Airplane Co, Huntsville. Svc: USA. Ret: 85. 20 yrs. VP, Tennessee Valley Chapter.

TASTAD, Jerome W., (LTC) (M65) (Jerry) Rt

1, Box 10, Millstadt, IL 62260. Dy: (314) 298-3423. Res: (618) 476-7805. S: Sharon. Job: Rockwell Int'l Corp, Midwest Region. Svc: USA. Ret: 85. 21 yrs.

TAYLOR, Billy R., (MAJ) (M57) 209 Cochise Court, Sierra Vista, AZ 85635. Res: (602) 458-5776. Ret: 87. 20 yrs. Past Sec, Old Tucson.

TAYLOR, Floyd V., (LTC) (M57) (Tex) 2361 North Kenmore, Arlington, VA 22207. Res: (703) 527-2868. S: Ruth. Svc: USA. Ret: 63. 24 yrs.

TAYLOR, James M., (LTC) (M60) (Jim) 5303 Raintree Circle, Oakwood, GA 30566. Res: (404) 532-1138. S: Joyce. Job: Cpl., Eastern Airlines. Svc: USA. Ret: 81. 28 yrs.

TAYLOR, Robert D., (COL) (M82) (Doug) 1937 Lincoln Road, Stockton, CA 95207. Dy: (209) 576-6300. Res: (209) 477-6011. S: Roberta.

TAYLOR, William D., (COL) (M60) (Don) 7114 Colgate Drive, Alexandria, VA 22307. Dy: (202) 863-8272. Res: (703) 765-4751. S: Dot. Job: Wash Rep, Litton G & CS. Svc: USA. Ret: 85. 32 yrs. Past Sec, Hanau Chapter.

TEDESCO, William J., (LTC) (M58) (Ted) 1854 Dolphin Blvd., So., St. Petersburg, FL 33707. Dy: (813) 345-4540. Res: (813) 345-4540. S: Barbara. Job: Pres, Executive Computer Services. Svc: USA, USAF. Ret: 69. 20 yrs. NEB. Past Pres, Suncoast Chapter.

TEESE, James L., (MAJ) (M57) (Jim) 5611 Farmbrook Drive, Charlotte, NC 28210. Dy: (704) 377-6730. Res: (704) 553-0576. S: Joann. Job: Principal, J. Teese Assoc. Svc: USA. Ret: 66. 21 yrs.

TELFER, Jon R., (COL) (M88) Box R, APO NY 09667. Dy: (322) 752-0725. Res: (322) 720-1317. S: Hiltrude. Job: Prgm Mgr, Augusta-Teamco Joint Venture. Svc: USA. Ret: 87. 30 yrs.

TERRY, Joel L., Jr., (COL) (M72) (Joe) 109 Sherwood Drive, Williamsburg, VA 23185. Res: (804) 229-4492. S: Charlotte. Past VP, Colonial Virginia Chapter.

THAYER, George E. Jr., (COL) (M59) 44 Blaine Drive, Palm Coast, FL 32037. Dy: (904) 445-6381. Res: (904) 445-6832. S: Jackie. Job: Univ Rsrch Corp, Ctr For Mgmt Dev, Instrct/ Curr Dev Specialist. Svc: USA. Ret: 78. 34 yrs.

THIRING, Florian A., (LTC) (M57) (Sparks) 25 Leaside Court, Manchester MD 63011. Dy: (314) 234-9955. Res: (314) 527-4256. S: Phyllis. Job: Sr Retrofit Services Engr, McDonnell Douglas. Svc: USA. Ret: 72. 21 yrs.

THOMAS, Frank J., (MR.) (M65) (Tom) 5474 Alwick Drive, St. Louis, MO 63129. Res: (314) 487-3156. S: Elaine. Svc: USA, USAF.

THOMAS, William S., (CW4) (M69) (Bill) 1710 Carriage Drive, Phenix City, AL 36867. Res: (205) 298-5925. S: Darlene. Job: Student, Troy St. U. Svc: USA. Ret: 83. 23 yrs.

THOMPSON, Jack H., (LTC) (M59) 182 Corinthia Drive, Newport News, VA 23602. Dy: (804) 887-0655. Res: (804) 877-7343. S: Mary Louise. Job: Academic Counselor, Saint Leo College. Svc: USA. Ret: 73. 28 yrs. Past Pres, Charter Life Member.

THOMPSON, Owen R., (LTC) (M63) (Dick) Logis-Tech, 1800 Diagonal Road, Alexandria, VA 22314. Dy: (703) 684-7117. Res: (703) 369-1240. S: Barbara. Job: Prgm Mgr, Logis-Tech. Svc: USA. Ret: 82. 20 yrs.

THOMPSON, Thomas E., (COL) (M60) (Tommy) P.O. Box 41699, Riyadh 11531 Saudi Arabia. Dy: 966-2-464-2068. Res: 966-2-464-3672. Job: Gen Mgr, Bell Hcptr Arabia, Ltd & VP, SOAREP, Ltd. Svc: USA. Ret: 77. 31 yrs.

THOMSON, Donald B., (LTC) (M57) (Tommy) 1660 Monterey Road, Apt. 9-1, Seal Beach, CA 90740. Res: (213) 431-8303. Job: Independent Consultant. Svc: USA. Ret: 62. 26 yrs.

THORNTON, Tommy W., (LTC) (M60) Route 2, Box 162, Mayville, MO 64469. Res: (816) 449-2024. S. Dixie. Job: Owner/Op, Timber-view Farm. Svc: USA. Ret: 80. 21 yrs.

TIDY, Chuck, (CW4) (M87) 1600 North Oak Street, No. 226, Arlington, VA 22209. Dy: (703) 284-4251. Res: (703) 841-2441. S. Leah. Job: Hughes Aft, Army Mktg Liaison. Svc: USA. Ret: 86. 20 yrs.

TILLER, William F., (LTC) (M82) (Fred) 5217 E. Elmwood Avenue, Mesa, AZ 85205. Dy: (602) 891-5511. Res: (602) 981-6901. S. Kay. Job: MDHC, Mgr, Bus. Devel., Mktg. Svc: USA. Ret: 85. 21 yrs.

TILLERY, George G., (COL) (M57) (George) Route 1, Box 761, Enterprise, AL 36330. Dy: (205) 347-2070. Res: (205) 347-2070. S. Betty. Svc: USA. Ret: 72. 33 yrs. VP, Army Avn Center Chapter. Past Pres.

TILLERY, Samuel E., (LTC) (M58) 469 Ena Road, Apt. 2601, Honolulu, HI 96815. Res: (808) 947-3812. S. Barbara. Job: Self Emp Vacation Rentals, Waikiki. Svc: USA. Ret: 68. 23 yrs.

TILLEY, Halcum G., (CW3) (M58) (Til) 30 Lakeshore Road, Lynn, MA 01904. Dy: (617) 594-2469. Res: (617) 593-8090. S. Yong Mi. Job: Jet Engine & Gas Turbine Tech., GE. Svc: USA. Ret: 79. 22 yrs.

TINGLER, William N., (COL) (M65) (Bill) Route 1, Box 45-I, Easton, KS 66020. Res: (913) 773-8226. S. Shirley. Svc: USA. Ret: 79. 32 yrs. Past Sec, Leavenworth Chapter.

TINSETH, Warren D., (CW4) (M62) 9527 Millers Ridge, San Antonio, TX 78239. S. Joyce. Job: Safety Director, So. West Texas St U. Svc: USA. Ret: 80. 31 yrs. Past VP, Jack H. Dibrell/Alamo.

TISON, Joseph T., (LTC) (M83) (Troy) 30 Hanary Drive, Lawrenceville, GA 30245. Dy: (404) 584-4407. Res: (404) 995-1362. S. Karen. Job: Mgr, Logistics Engrg, Rockwell Int'l. Svc: USA. Ret: 85. 20 yrs.

TOBIASEN, Richard D., (LTC) (M58) (Toby) 16401 Audubon Village Dr, Grover, MO 63040-1719. Dy: (314) 653-1212. Res: (314) 458-4804. S. Patricia. Job: Sr. Integ Log Sys Mgr, Emerson Electric Co. Svc: USA. Ret: 77. 21 yrs.

TODD, Alan R., (COL) (M72) (Al) 1120 Sotogrande Blvd., Apt. 141, Euless, TX 76040. Dy: (817) 280-4097. Res: (817) 540-0001. S. Jane. Job: Test Coordinator, Bell Hcptr Textron. Svc: USA. Ret: 87. 29 yrs. Past Pres, Southern California Chapter.

TOOD, Edith M., (MRS.) (M70) (Toddy) 709 Laccia Circle, Lake Worth, FL 33467. Res: (305) 968-5225. Svc: USA. Ret: 73. 25 yrs.

TOLFA, Edward, Jr., (COL) (M59) (Ed) 202 Yorkville Place, De Bary, FL 32713. Dy: (407) 894-6061. Res: (407) 668-4710. S. Helen. Job: Sr Mgmt/Pgm Analyst, Advanced Tech Inc. Svc: USA. Ret: 86. 32 yrs.

T The SPOOF Roster

TOLSON, John J., III, (LTG) (M57) (Jack) 1610 Canterbury Road, Raleigh, NC 27608. Dy: (919) 781-0524. S. Margaret. Ret: 73. 39 yrs. NEB. HOF.

TOUCHET, James C., (LTC) (M58) (Jim) 8412 Springhill Court, Fort Worth, TX 76180. Svc: USA. Ret: 73. 28 yrs.

TOURILLIOTT, Raymond J., (COL) (M57) (Ray) 1225 Forestville Drive, Great Falls, VA 22066. Dy: (202) 944-7002. Res: (703) 759-3656. S. Judith. Job: Satellite Communications, Intelsat, Wash, DC. Svc: USA. Ret: 79. 31 yrs.

TOW, James L., (COL) (M58) (Jim) 907 Green Terrace, Duncanville, TX 75137. Dy: (214) 266-7587. Res: (214) 296-1999. S. Barbara. Job: Pgm Mgr, Extended Air Defense Systems, LTV, Missiles Division. Svc: USA. Ret: 80. 28 yrs. Past Pres, Tennessee Valley Chapter.

TOWNSEND, Harry W., (COL) (M59) 11741 Loveloy Street, Silver Spring, MD 20902. Dy: (301) 593-5406. Res: (301) 593-3108. Svc: USA. Ret: 78. 34 yrs. NEB.

TOWNSEND, James O., (COL) (M59) (Jim) 102 White Oak Bend, Ozark, AL 36360. Dy: (205) 598-2401. Res: (205) 774-2907. S. Olive. Job: Chairman, Fort Rucker Nat'l Bank. Svc: USA. Ret: 68. 30 yrs.

TRACH, Brian L., (MAJ) (M84) (Bt) 103 Silverton Circle, Madison, AL 35758. Dy: (205) 461-3872. Res: (205) 895-0202. S. Doreen. Job: Trng Analyst, Boeing. Svc: USA. Ret: 87. 20 yrs.

TRAGESSER, John N., (COL) (M85) (Nick) 740 Brittany Lane, St. Louis, MO 63130. Dy: (314) 429-6911. Res: (314) 721-3918. S. Diane. Job: Group Mgr, VSE Corp. Svc: USA. Ret: 88. 29 yrs.

TRAINOR, Richard J., (DR.) (M79) (Dick) 2106 E Gallows Road, Vienna, VA 22180. Dy: (703) 893-0383. Res: (703) 860-3940. Job: Pres, Trainor Assoc., Inc. Svc: USA.

TRAPP, Turner J., (COL) (M57) Route 1, Box 451, Duck Hill, MS 38925. Dy: (601) 565-2850. Res: (601) 565-2850. S. Martha. Job: Registered Rep, Source Securities. Svc: USA. Ret: 81. 30 yrs.

TRAYER, Daniel G., (LTC) (M57) (Dan) 102 West Street, Greensboro, GA 30642. Dy: (404) 546-5375. Res: (404) 453-2588. S. Betty. Job: Coordinator, Mktg & Distributive Ed, Clarke City Sch Dist. Svc: USA. Ret: 69. 21 yrs.

TRENT, Ben, Jr., (CW4) (M79) (Ben) 19 Pinehurst Court, St. Peters, MO 63376. Dy: (314) 429-0017. Res: (314) 928-6249. S. Thelma. Job: Science & Technology Inc. Svc: USA. Ret: 84. 29 yrs.

TRENT, William E., (COL) (M59) (Bill) 3708 Howsen Avenue, Fairfax, VA 22030. Dy: (703) 893-9261. Res: (703) 273-2183. S. Margaret. Job: Sr Analyst, Computer Res Mgmt Inc. Svc: USA. Ret: 87. 30 yrs.

TRICKLER, Roger D., (LTC) (M64) (Trick) 115 Blackhawk Drive, Daleville, AL 36322. Dy: (205) 255-6481. Res: (205) 598-1688. S. Miriam. Job: Equip Spec, Elec, DAC. Svc: USA. Ret: 81. 26 yrs.

TRIGGS, Wayne I., (MAJ) (M78) 2033 Canter-

bury Square, Anniston, AL 36201. Res: (205) 831-5092. Svc: USA. Ret: 66. 25 yrs.

TRUESDALE, Dana L., (CW4) (M82) (Butch) 73 Huxley Place, Newport News, VA 23606. Dy: (804) 638-4400. Res: (804) 595-6544. S. Jan. Job: Org. Analyst, Allen Corp of America, Hampton. Svc: USA, USAF. Ret: 86. 34 yrs.

TRUMPFELER, Herbert G., (CSM) (M73) (Trump) c/o CPO Nuernberg, APO NY 09696. Dy: (009) 838-2067. Res: (062) 245-5975. S. Molly. Job: Pers Staff Spec, CPO, USAREUR. Svc: USA. Ret: 76. 35 yrs.

TUGGIE, Howard J., (COL) (M57) (Jim) Bhasia, 50 Loyang Way, Singapore 1750. Dy: (065) 542-2422. Res: (065) 732-8516. S. Janet. Job: Dir, Customer Spt, Bell Hcptr Asia. Svc: USA. Ret: 77. 29 yrs. Past Pres, Coastal Empire Chapter.

TULLOCH, John S., (CW4) (M65) 12 Blackhorse Lane, Media, PA 19063-4614. Dy: (302) 323-2409. Res: (215) 565-6058. S. Janice. Job: Test Pilot, Boeing Helicopter Co. Ret: 81. 20 yrs. Past VP, Southern California Chapter.

TURMAN, Willard G., (CW4) (M62) (Will) 6509 E. 12th Street, Tucson, AZ 85710. Dy: (602) 622-3671. Res: (802) 745-5108. S. Carol. Job: Control Dept., America West Airlines Inc. Svc: USA. Ret: 76. 26 yrs.

TURNAGE, John O., (COL) (M75) (Jack) McDonnell Douglas Hcptr., 500 N.W. Plaza, Ste. 1016, St. Ann, MO 63074-2209. Dy: (314) 233-9866. Res: (314) 928-7175. S. Lyle. Job: Mgr, St. Louis Ops, McDonnell Douglas. Svc: USA. Ret: 85. 25 yrs.

TURNER, Edwin H., (LTC) (M59) (Ed) 21 Trouville Drive, Parsippany, NJ 07054. Dy: (201) 785-5691. Res: (201) 386-9799. S. Awilda. Job: Mgr, Egyptian Programs, Keatfoft Guidance & Navigation Corp. Svc: USA. Ret: 79. 22 yrs. Past VP.

TURNER, Rex M., Jr., (LTC) (M70) 1845 Bough Ave, No. D, Clearwater, FL 34620. Dy: (813) 821-7855. Res: (813) 530-4770. Job: Assoc. Mktg Prop Inc. Ret: 79. 24 yrs. Past Pres, Pikes Peak Chapter.

TURVEY, Clifford V., (CW4) (M57) Rt 1, Box 2291 C, Converse, TX 78109-9801. Rt. 70. 26 yrs. Aviator of Yr 1959.

TYSON, Robert M., Jr., (LTC) (M58) 9470 Wilson Road, Elberta, AL 36530. Res: (205) 986-5641. S. Joyce. Svc: USA, USAF. Ret: 68. 24 yrs.

UUUUUU - WWWWW

ULERY, Vincent L., (COL) (M57) (Vinco) 1909 Manor Circle Dr Se, Winter Haven, FL 33880. Res: (813) 299-8431. S. Jewel. Svc: USA. Ret: 69. 22 yrs.

ULZHEIMER, Robert, (LTC) (M58) (Bob) 4011 Gunned Road, Norcross, GA 30092. Dy: (404) 526-6252. Res: (404) 447-1125. S. Loy. Job: MIS Analyst, GA Power Co. Svc: USA. Ret: 82. 24 yrs.

UNDERWOOD, Orile J., (LTC) (M57) (Jim) 11917 Brookwood Circle, Austin, TX 78750. Dy: (512) 837-8890. Res: (512) 258-5437. S. Gynda. Job: Gm, Renner Tech Svc Inc. Svc: USA. Ret: 69. 22 yrs.

URRUTIA, Carlos E., (COL) (M59) 3517 Bondwood Drive, Columbus, GA 31906. Res: (404) 687-6461. S. Anne. Svc: USA. Ret: 74. 27 yrs. Past Treas, Follow Me Chapter.

VADEN, Floyd L., (LTC) (M70) (Len) 4426 Dody Street, Corpus Christi, TX 78411. Dy: (512) 939-2001. Res: (512) 852-4605. S: Evelyn. Job: Force Modernization Ofc, CCAD. Svc: USA. Ret: 63. 25 yrs.

VALAER, John P., (CW4) (M52) 151 Country Club Road, Shalimar, FL 32579. Dy: (904) 651-3949. S: Charlotte. Svc: USA. Ret: 83. 30 yrs.

VANDIVER, Gilmer L., (LTC) (M58) Route 6, Box 6400, Cleveland GA 30528. Dy: (404) 865-4673. Res: (404) 865-4402. S: Brenda. Job: Real Est. Broker, Gilmer Vandiver. Svc: USA. Ret: 69. 20 yrs.

VAN DYKEN, Harold B., (COL) (M58) (Van) 11111 Old Castle Road, Valley Center, CA 92082. Res: (619) 749-8721. S: Esther. Job: Owner, Harold Van Dyken Real Estate. Svc: USA. Ret: 75. 34 yrs.

VARNON, Jerry R., (LTC) (M59) (Jerry) 3383 Reedy Drive, Armandale, VA 22003. Dy: (703) 556-6880. Res: (703) 560-4515. S: Sandra. Job: Pres, Mamire, Inc.. Svc: USA. Ret: 81. 26 yrs.

VAUGHAN, Carroll A., (CW4) (M68) Dyncorp, c/o NATO SUPACT, European AVCARD, APO NY 09867. Dy: 011 32-2-752-0790. Res: 011 32-3-725-1677. S: Sparkle. Job: Site Mgr, European AVCARD Dyncorp. Svc: USA. Ret: 88. 20 yrs. Past Trea, Stuttgart Chapter.

VAUGHT, James B., (LTJ) (M78) (Jim) 1603 Ventura Villas, Mount Pleasant, SC 29464-9539. Dy: (803) 881-3666. Res: (803) 881-9639. S: Winifred. Job: Military Systems Advisor. Svc: USA. Ret: 83. 38 yrs.

VEAL, Monte R., (LTC) (M70) 2317 Bee Ridge Road, Columbia, SC 29223. Dy: (803) 788-0849. Res: (803) 788-5021. S: Joan. Job: Pres, VJM, Inc./Fast Foods-Real Est Dev. Ret: 83. 20 yrs.

VERTRES, Carl R., (CW4) (M59) 402 N. Main Street, Copperas Cove, TX 76522. Res: (817) 547-6989. S: Lois. Ret: 73. 26 yrs.

VESSEY, John W., Jr., (GEN) (M70) (Jack) Star Route, Box 136A, Garrison, MN 56450. S: Avis. Svc: USA. Ret: 85. 46 yrs.

VIERLING, Raymond A., (CWO) (M58) 14039 Matthews Drive, Woodbridge, VA 22191. Dy: (703) 664-4418. Res: (703) 494-5249. S: Margaret. Job: Instructor, Ft Simulador/DACI. Svc: USA. Ret: 67. 20 yrs. Past Trea, North Texas Chapter.

VOELKEL, Eugene, (LTC) (M58) (Gene) 8 Ravens Perch, Bryan, TX 77802. Dy: (409) 845-1208. Res: (409) 774-4405. S: Jane. Job: Admin Assn for T&I, Texas A&M Univ. Svc: USA. Ret: 79. 22 yrs. Past Sec.

VON KANN, Clifton F., (MG) (M57) (Von) 4311 Torchlight Circle, Bethesda, MD 20816. Dy: (202) 898-1333. Res: (301) 320-2920. S: Kathryn. Job: Pres, Nat'l Aeronautic Assoc.; Pres, Federation Aeronautique Int'l. Svc: USA. Ret: 65. 28 yrs.

WWWWWWW

WADDELL, Roger W., (LTC) (M59) 1601 Foxhall Road, Savannah, GA 31406. Dy: (912) 964-3646. Res: (912) 354-1626. S: Laurelei. Job: Mgr Eng'g Resources & Admin, Gulfstream Aero Corp. Svc: USA. Ret: 80. 22 yrs. Past VP, Fort Bragg Chapter.

WAGG, Robert A., (COL) (M63) 4004 Bellvue

W The SPOOF Roster

Drive, St. Charles, MO 63303. Dy: (202) 289-5862. Res: (314) 928-6106. S: Eddie Mae. Job: Washington Rep, Bell Hqpr Textron Inc. Svc: USA. Ret: 67. 30 yrs. Past Trea.

WALDEN, Oliver W., (COL) (M57) (Ollie) 215 Skyline Drive, Barrington, IL 60010. Dy: (312) 381-1524. S: June. Job: Mktg Rep II, Schools Liquid Asset Fund. Svc: USA. Ret: 82. 32 yrs.

WALDRON, Gerald L., (COL) (M58) (Gery) 20992 Avenida Arapalo, El Tora, CA 92630. Dy: (213) 379-3412. Res: (714) 768-8735. S: Karen. Job: Pres, Waldron Ent., Hermosa Beach. Svc: USA. Ret: 73.

WALKER, James M., (COL) (M62) (Jim) 506 Bryant Street, Shelbyville, TN 37100-3404. S: Jane. Job: Consultant, James M. Walker Ent.; Owner, Quail Valley Hunt Club. Svc: USA. Ret: 81. 23 yrs. Past VP, Lindbergh Chapter.

WALKER, John A. Jr., (LTC) (M87) (USA) USAA Building/AB-1 E, San Antonio, TX 78288. Dy: (512) 498-2435. Res: (512) 654-1711. S: Mary. Job: Dir., Mil Affairs/USAA. Svc: USA. Ret: 85. 23 yrs.

WALKER, Milburn F., (MR.) (M69) (Mid) 10749 Kingwood Drive, Corpus Christi, TX 78410. Res: (512) 241-1468. S: Louise. Svc: USA. USAF. 4 yrs.

WALKER, Milton H., (LTC) (M59) (Milt) 147 Inglewood Drive, Longview, VA 98632. Dy: (206) 636-5074. Res: (206) 636-5074. S: Ilse. Job: Owner/Pilot Magik Aire. Svc: USA. Ret: 77. 24 yrs.

WALKER, Paul S., (LTC) (M86) (Wing) 13219 Country Club Drive, Tavares, FL 32778. Res: (904) 742-2960. S: Julie. Svc: USA. Ret: 68. 24 yrs.

WALKER, Travis L., (COL) (M54) (Trav) 816 Eldorado Avenue Se, Huntsville, AL 35802. Dy: (205) 837-2901. Res: (205) 882-9451. S: Louise. Job: VP, The EC Corp. Ret: 83. 31 yrs. Past VP, Tennessee Valley Chapter.

WALKER, Wayne T., (CW4) (M83) (Tom) 18241 Autumn View Drive, Prairieville, LA 70769. Res: (504) 622-5362. S: Jean. Job: Hqpr Pilot, Petroleum Hqpr Inc. Svc: USA. Ret: 84. 27 yrs.

WALSH, John A., (CW4) (M65) Rt.3, Box 525, Montross, VA 22620. Dy: (703) 971-1800. Res: (804) 472-3929. S: Lori. Job: Real Estate Broker, Fitzgerald & Walsh. Svc: USA. Ret: 78. 23 yrs.

WANN, Henry S., (LTC) (M57) 250 Nottingham Road, Williamsburg, VA 23185. Res: (804) 229-2686. S: Georgianna. Svc: USA. Ret: 64. 21 yrs. Past VP.

WARD, Robert, (LTC) (M82) (Bob) 1395 Pine Lake Dr, NW, Stuart, FL 34994. Dy: (407) 220-5277. Res: (407) 692-9515. S: Thresia. Job: Test Pilot, Grumman Acft Corp. Svc: USA. Ret: 86. 22 yrs.

WARZECHA, Edward M., (LTC) (M57) (Ed) 16 Hall Street, Daleville, AL 36322. Res: (205) 598-4394. S: Jo. Svc: USA. Ret: 68. 26 yrs. Past VP, Army Avn Center Chapter.

WASSON, James C., III, (CPT) (M68) Rt. 2, Box 72, Loris, SC 29569-9529. Res: (803) 756-1590. S: Martha. Svc: USA. Ret: 75. 10 yrs.

WATSON, Ronald J., (LTC) (M60) (Ron) P.O. Box 155, Warrenton, SC 29851-0155. Res: (803) 593-9089. S: Carol. Job: Sales Rep, Roller Bearing Co of America. Ret: 74. 22 yrs.

WEATHERSPOON, Samuel R., (CW2) (M66) (Sam) 1018 E. Northfield Blvd, Murfreesboro, TN 37130-1223. Res: (615) 890-3857. Svc: USA. Ret: 85. 20 yrs.

WEAVER, Carl A., Jr., (LTC) (M61) 15897 Melody Lane, Dumfries, VA 22026. Dy: (703) 760-1076. Res: (703) 670-8934. S: Ann. Job: Prog. Mgr, Questech. Svc: USA. Ret: 80. 21 yrs.

WEAVER, Eugene E., (LTC) (M57) Claragraben 136, Basel Switzerland 4057. Res: 6811004. S: Lilian.

WEBB, Charles L., (COL) (M60) (Charlie) 103 Barbara Drive, Enterprise, AL 36330. Dy: (205) 793-8918. Res: (205) 393-1598. S: Luana. Job: Dir., Emergency Svcs, SE AI Med Ctr.. Svc: USA. Ret: 87. 31 yrs.

WEBB, Ivan R., (MAJ) (M86) (Bob) 2510 S. Farmer Street, Richlands, VA 24141. Res: (703) 964-9540. S: Alice. Job: Co Cdr, Col 3rd Avn Bn, Avn Bde, VA Defense Force. Svc: USA. Ret: 69. 26 yrs.

WEBBER, Herbert M., (LTC) (M57) (Herb) 2850 Gayle Lane, Auburn, CA 95603. Res: (916) 878-7023. S: Lilian. Svc: USA. Ret: 82. 28 yrs. Past Pres, Bonn Area Chapter.

WEINSTEIN, Leslie H., (COL) (M60) (Les) 4422 Winderwood Circle, Orlando, FL 32811. Dy: (407) 299-8856. Res: (407) 299-8856. S: Attila. Svc: USA. Ret: 86. 30 yrs. Past Pres, Lindbergh Chapter.

WELLS, James F., (COL) (M58) (Jim) 941 Margaret Street, Monterey CA 93940. Dy: (408) 375-4025. S: Mary Frances. Svc: USA, USMC. Ret: 66. 37 yrs. 62 McClellan Award.

WESCOTT, William H., (LTC) (M87) (Bill) 1038 N. Ambrosia, Mesa, AZ 85205. Dy: (602) 891-5728. Res: (602) 981-3761. S: Frances. Job: System Stry Eng, McDonnell Douglas Hqpr. Svc: USAF. Ret: 68. 14 yrs.

WESTRICH, Ralph L., (COL) (M68) (Wes) 1401 S. Cage Blvd, No. 21, Pharr, TX 78577. Res: (512) 781-3117. S: Vivian. Ret: 78. 30 yrs. Past Sr VP.

WETZEL, Robert L., (LTJ) (M83) (Sam) Wetzel International Inc, P.O. Box 5387, Columbus, GA 31906. Dy: (404) 322-2506. Res: (404) 576-4204. S: Elene. Job: Pres, Wetzel Int'l Inc. Svc: USA. Ret: 86. 34 yrs.

WHITE, James M., (CW3) (M69) (Jim) 811 Forrest Heights Drive, Huntsville, AL 35802. Dy: (205) 876-2186. Res: (205) 862-1293. S: Teresa. Job: Acft Pilot, USA Missile Cmd, RSA. Svc: USA. Ret: 77. 20 yrs.

WHITE, Jewel G., (LTC) (M60) 213 E. 6th, Mtn Home, AR 72653. Dy: (501) 425-6800. Res: (501) 482-5945. S: Joyce. Job: Dir, Mtn Home Center, No Ark Comm College. Svc: USA. Ret: 73. 20 yrs.

WHITE, John W., Jr., (LTC) (M64) 520 Harbor Drive, North, Indian Rocks Beach, FL 34635. Dy: (813) 596-9003. Res: (813) 596-0074. S: Larue. Job: Owner, Beach Tropics. Svc: USA. Ret: 84. 35 yrs. Past VP, Suncoast Chapter.

WHITE, Roy, (COL) (M64) 48 Mallard Road, Middletown, NJ 07748. Dy: (201) 890-8288. Res: (201) 671-3039. S: Peggy. Job: Dir, Radar

Prog, Plessey Electronic Systems Corp. Ret: 81. 26 yrs. Past Pres. Monmouth Chapter.

WHITE, William G., (LTC) (M57) (Whizzer) 376 Gasparillo Avenue, Port St. Lucie, FL 34983. Res: (407) 878-5427. Svc: USA. Ret: 70. 28 yrs.

WHITENER, John, (CW3) (M87) 1112 Westview Drive, Ozark, AL 36360. Dy: (205) 774-6411. Res: (205) 774-6994. Svc: Anne. Job: Prudential Ins Co. Ret: 68. 20 yrs.

WHITTEN, Millard, (LTC) (M62) (White) 1123 Winding Branch Cir, Dunwoody, GA 30338. Res: (404) 394-2874. Svc: Helen. Job: Owner, Cultured Marble Co. Svc: USA. Ret: 71. 24 yrs. Past Pres, Indianapolis Chapter.

WICKWARE, A. W., (LTC) (M87) (Wes) 718 Cottonwood Circle, Desoto, TX 75115. Dy: (214) 259-9992. Res: (214) 242-8569. Svc: Jo Ann. Job: Div Mgr, Rand McNally Map Services. Ret: 76. 27 yrs.

WILEY, Noble J., (LTC) (M62) (Jim) 9327 Hobart Court, Fairfax, VA 22032. Dy: (703) 578-5318. Res: (703) 978-9208. Svc: Joan. Job: Customer Svc Specialist, Electronic Data Sys Corp. Eds. Svc: USA. Ret: 82. 22 yrs.

WILHELM, Robert S., (LTC) (M64) (Bob) 448 Roxbury Road, Valparaiso, IN 46383. Dy: (219) 977-2151. Res: (219) 462-3703. Svc: Joan. Job: Dir, Army Inst, Gary Cmty Schol Corp. Svc: USA. Ret: 86. 26 yrs.

WILKINS, Henry J., (LTC) (M58) (Henry) 1x, Box 336, Guyton, GA 31312. Dy: (912) 754-6071. Res: (912) 772-3340. Svc: Marise. Job: Owner/Op, Hickory Hill Farm; Effingham City Tax Comm. Svc: USA. Ret: 70. 21 yrs. Past Sr VP, Greater-Atlanta Chapter.

WILKINSON, Robert M., (CPT) (M64) (Bob) 1129 W. Imhoff Road, Norman OK 73072. Dy: (405) 344-6380. Res: (405) 364-4552. Svc: Kate. Svc: USA. Ret: 73. 23 yrs. Past Tra.

WILLIAMS, Chas. J., Jr., (CW4) (M58) (Charlie) 6688 Cactus Road, Mechanicsville, VA 23111. Dy: (804) 786-5772. Res: (804) 730-1273. Svc: Monique. Job: Avn Spec, Commonwealth of Va. Svc: USA. Ret: 81. 32 yrs. Past Tra, Washington DC Chapter.

WILLIAMS, Howard M., (COL) (M58) (1113) Five Point Road, Virginia Beach, VA 23454. Dy: (804) 463-9800. Res: (804) 481-3478. Svc: Miriam. Job: Mktg Assoc & Prof Financial Planner, JJ Schopen & Assoc. Svc: USA. Ret: 83. 30 yrs.

WILLIAMSON, Kenneth P., (MR.) (M87) 536 Hoey St, Long Branch, NJ 07740. Res: (201) 229-4654. Svc: Mary. Svc: USA. 4 yrs.

WILLIAMSON, Neil S., III, (COL) (M76) 1624 Havemeyer Lane, Redondo Beach, CA 90278. Dy: (213) 616-3280. Svc: Sue. Job: PM, K-1, Hughes Aerial. Svc: USA. Ret: 81. 23 yrs. Past Pres, Tennessee Valley Chapter.

WILLIAMS, Ramon R., (CW4) (M58) 11213 Delta Torre, Austin, TX 78750. Res: (512) 258-6200. Svc: Teresa. Job: Real Est Broker, Ray Wms Real Estate; Base Mgr, Air Logistics, Inc. Svc: USA. Ret: 75. 28 yrs. Past Sec.

WILLIAMS, Robert L., (CW4) (M63) (Willie) Route 5, Box 310, Livingston, TX 77351. Svc: Bessie. Job: 49th Trans Co/MH/Stockton. Past VP, Monterey Bay Chapter.

WILLIAMS, Robert M., (LTC) (M57) (Bob) 4917 Chamblee Dunwoody Rd, Dunwoody, GA 30338. Dy: (404) 458-8111. Res: (404) 393-

W The SPOOF Roster

2663, S. Dixie. Job: Int'l Sales Mgr, Neptune Int'l Div. Svc: USA. Ret: 73. 21 yrs. Past Pres.

WILLIAMS, Robert R., (LTJ) (M57) (Bob) 5825 Jacqueline Road, Ft Worth, TX 76112. Dy: (817) 429-4728. Res: (817) 429-4728. Svc: Jean. Svc: USA. Ret: 74. 34 yrs. NEB. HOF.

WILLWERTH, Dean R., (LTC) (M58) (Dean) 78 Primrose Drive, Trumbull, CT 06611. Dy: (203) 938-1316. Res: (203) 378-4752. Svc: Lil. Job: Customer Svc, Mgr 153155 Plans, Avco Lycoming Textron. Svc: USA. Ret: 80. 26 yrs. Past VP.

WILSON, Carl A., Jr., (LTC) (M58) 95-204 Alaalala Loop, Mililani Town HI 96789. Dy: (808) 521-6502. Res: (808) 623-3947. Svc: Toni. Job: Pres, Mgmt Advisory Svcs, Inc. Svc: USA. Ret: 73. 23 yrs.

WILSON, Deanol B., (MAJ) (M63) (Willie) 6705 Red Jacket Road, Springfield, VA 22152. Res: (703) 451-7032. Svc: USA, USAF. Ret: 59. 20 yrs.

WILSON, Donald E., (COL) (M59) (Gene) 9421 Zircon Drive Sw, Tacoma, WA 98498. Res: (206) 582-9249. Svc: Eleanor. Job: Handyman, Ellie Wilson Ent. Svc: USA. Ret: 88. 30 yrs.

WILSON, Gary L., (LTC) (M58) (Tom) Texas Instruments, 11818 Borman Drive, St. Louis, MO 63146. Dy: (314) 589-7800. Svc: Sue. Job: Mgr., Mktg, St. Louis Office, Texas Instruments. Svc: USA. Ret: 76. 21 yrs. Past VP, North Texas Chapter.

WILSON, Leonard R., (MAJ) (M58) (Len) 3976 Chemeuhay Blvd., Lake Havasu City, AZ 86403. Dy: (602) 855-4066. Res: (602) 453-5498. Svc: Patty. Job: Teacher/Coach, Sch Dist 1. Ret: 73. 20 yrs.

WILSON, Walter C. Jr., (LTC) (M59) 8534 Mathonia Avenue, Jacksonville, FL 32211. Res: (904) 724-5342. Svc: USA. Ret: 77. 26 yrs.

WINGATE, Charles S., (COL) (M57) (Lani) Rt. 2, Box 471-b, New Brockton, AL 36351. Dy: (205) 598-6251. Res: (205) 894-5064. Svc: Betty. Job: AH-64 Fielding PM, McDonnell Douglas Hptr Co. Svc: USA. Ret: 80. 32 yrs. Past VP, Southern California Chapter.

WINGROVE, Marvin V., (CW0) (M51) (Windy) 3 Hilary Court, Novato, CA 94947. Res: (415) 892-6410. Svc: Laurene. Svc: USA. Ret: 60. 21 yrs.

WINKEL, Paul P., Jr., (COL) (M73) 6407 Old Scotts Court, Springfield, VA 22152. Res: (703) 569-9286. Svc: USA. Ret: 86. 32 yrs.

WINSLOW, Roger D., Jr., (MAJ) (M57) 3313 Timber Trail Dr, Antioch, TN 37013. Dy: (615) 741-5622. Res: (615) 361-7184. Svc: Margaret. Job: Tng Officer, State of TN. Svc: USA. Ret: 80. 20 yrs. Past VP.

WINTERS, Joe B., (CPT) (M71) 8305 Ox Yoke Cr., Maple Plain, MN 55359. Dy: (612) 540-8063. Res: (612) 479-4344. Svc: Linda. Job: Dir, Loss Prevention, Carlson Cor/Radisson Hotels. Svc: USA. Ret: 75. 18 yrs.

WITHERS, Peter C., (LTC) (M67) (Pete) 3180 Galangale Way, Doraville, GA 30340. Dy: (404) 656-7390. Res: (404) 288-0462. Svc: Sonya. Job: Mgr, Admin Svc, State of GA. Svc: USA. Ret: 75. 23 yrs. Past Sec, Greater-Atlanta Chapter.

WOLFE, Alfred J., (LTC) (M57) (Moon) 8 Meadow Circle, Williamsburg, VA 23185. Res: (804) 564-0667. Svc: Moly. Svc: USA. Ret: 67. 20 yrs.

WOLFF, William H., (LTC) (M57) 204 Quayside Circle, No. 601, Mattland, FL 32751. Svc: Ina. Job: Dav. Ret: 72. 26 yrs.

WOLIVER, Clarence H., (COL) (M58) (Clancy) 110 Downing Drive, San Antonio, TX 78209. Dy: (512) 641-8902. Res: (512) 829-4430. Svc: Lois. Job: Pres, San Antonio Medical Fndtn. Svc: USA. Ret: 86. 31 yrs.

WOOD, Douglas J., (LTC) (M59) (Doug) 4341 Thomas Drive, P.O. Box D29, Panama City Beach, FL 32407. Dy: (904) 871-1773. Res: (904) 234-7246. Svc: Carolyn. Job: Pres, Wood Acre Rentals. Svc: USA. Ret: 79. 29 yrs.

WOOD, Gordon F., (LTC) (M57) 1956 Canterbury Square, Anniston, AL 36201. Res: (205) 831-1258. Svc: USA. USA. Ret: 72. 27 yrs.

WOOD, Norman M. Jr., (LTC) (M68) (Norm) 5143 Heritage Lane, Alexandria, VA 22311. Dy: (202) 646-4850. Res: (703) 996-9248. Job: Ssr Analyst, ARINC Research Corp. Svc: USA. Ret: 86. 22 yrs.

WOOD, Robert W., (COL) (M57) 4850 Laure Lane, Fort Myers, FL 33908. Res: (813) 481-8415. Svc: Norma. Svc: USA. Ret: 70. 26 yrs.

WOODARD, Larry H., (LTC) (M79) (Woody) 550 Eastview Drive, Madison, AL 35758. Dy: (205) 895-8626. Res: (205) 461-8613. Svc: Mary Anne. Job: Sr Logistics Analyst, Cas Inc. Svc: USA. Ret: 86. 29 yrs.

WOODMANSEE, Donald R., (LTC) (M87) (Woody) RR 1, Box 53C, Cherokee, OK 73728. Res: (405) 596-2164. Svc: Norma. Svc: USA. USN. Ret: 71. 27 yrs.

WOODRUFF, Albert R., (LTC) (M58) (Al) 2258 E. Downing Circle, Mesa, AZ 85213. Res: (602) 835-0202. Svc: Joanne. Ret: 75. 22 yrs.

WOODS, George J. Jr., (COL) (M80) 661 Shannon Road, Bolling Springs, PA 17007. Res: (707) 258-5173. Svc: Barbara. Job: Avn Training Coordinator, Commonwealth of PA. Svc: USA. Ret: 83. 27 yrs.

WOOLF, Harold E., (LTC) (M82) (Paddy) 320 Knowlwoods Terrace, Roswell, GA 30075. Dy: (404) 993-3016. Res: (404) 993-3016. Svc: Elizabeth. Svc: USA. Ret: 62. 25 yrs.

WOZNIAK, Leon S., (1SG) (M75) (Lee) 6201 Belshire Drive, Belmont, MI 49306. Job: Technical Instructor, Lockheed Arabia-Heb-2. Svc: USA. Ret: 78. 27 yrs.

WRAY, Donald P., (COL) (M58) (Don) 21 Meadowbrook City Club, Ballwin, MD 63011. Dy: (314) 429-4700. Res: (314) 394-4696. Svc: Theresa. Job: Mgr, Boeing Hptrs, St. Louis. Svc: USA. Ret: 84. 28 yrs. Past Pres, Washington DC Chapter.

WRIGHT, Dean E., (COL) (M69) Rd 1, Box 378, Farmingdale, NJ 07727. Dy: (201) 938-9000. Res: (201) 938-6146. Job: Logistics Mgr, Frequency Engng Lab. Svc: USA. Ret: 81. 33 yrs.

WRIGHT, John M., Jr., (LTC) (M64) (Jack) 3813 Acapulco Court, Irving, TX 75062. Dy: (214) 717-4170. Res: (214) 717-4170. Svc: Helene. Svc: USA. Ret: 72. 37 yrs. NEB.

WRIGHT, Martin D., (SGM) (M88) (Marty) 2638 Angela Drive, Granite City, IL 62040. Dy: (314) 263-2840. Res: (618) 797-0258. Svc: Kay. Job: Logis Mgmt Spec, Int'l Logis, USAASC.

Svc: USA. Ret: 88. 26 yrs.

WUJEK, Stanley J., (CW4) (M62) 2808 Dalewood Drive, Columbus, GA 31907. Dy: (404) 835-7569. Res: (404) 563-6949. S: Carolyn. Job: Chief Test Pilot, Ft. Benning; Dir, Logistics. Svc: USA. Ret: 85. 27 yrs.

WULF, Roy A., (COL) (M59) (Roy) 4125 Drexel Drive, Binghamton, NY 13903. Dy: (607) 721-5027. S: Cynthia. Job: Link Fit Sim Corp. Svc: USA. Ret: 81. 25 yrs.

WYLLIE, Clement A., (COL) (M59) (Clem) Box 291, Route 2, Annabelle Lane, Cleveland, TN 37312. Dy: (312) 987-4000. Res: (615) 336-5194. S: Aileen. Job: VP, Int'l Telemedia Inc., Chicago. Svc: USA. Ret: 79. 34 yrs.

YYYYY - ZZZZZ

YAGER, Lawrence W., (LTC) (M68) (Larry) 5258 Westwood Drive, St. Charles, MO 63303. Dy: (314) 553-4512. Res: (314) 928-0449. S: Carolyn. Job: Sr Planner, Emerson Electric. Svc: USA. Ret: 83. 21 yrs.

YAMASE, George, (1SG) (M84) (Yoshi) 1908

Stardust, Killeen, TX 76543. Dy: (817) 287-2708. Res: (817) 699-0816. S: Laura J. Job: DA Sample Data Collector, Cobro Corp. Svc: USA. Ret: 85. 27 yrs.

YENSAN, David A., (MAJ) (M66) 3947 W. Chapel Road, Aberdeen, MD 21001. Dy: (301) 675-0900. Res: (301) 272-4688. S: Rosi. Job: Pgm Mgr, Analytics, Inc. Edgewood. Svc: USA. Ret: 81. 20 yrs.

YOUNG, George J., (LTC) (M62) Fmca, No. F87396, P.O. Box 44209, Cincinnati, OH 45244. S: Venita. Svc: USA. Ret: 72. 27 yrs. Past Pres.

YOUNG, James S., (MAJ) (M70) (Jim) Rt 2, Box 133, Enterprise, AL 36330-9750. Dy: (205) 255-2414. Res: (205) 347-8968. S: Mary K. Job: Flight Instructor, Flight Safety International. Svc: USA. Ret: 87. 20 yrs.

YOUNG, John D., (LTC) (M85) File And Drum Tree Farm, Rd-1, Barto, PA 19504. Dy: (215) 845-7433. Res: (215) 845-7433. S: Petey. Job: Owner, File And Drum Tree Farm. Svc: USA. Ret: 71. 24 yrs.

YOUNG, Ray A., (COL) (M57) 3115 Trenholm Drive, Oakton, VA 22124. Dy: (301) 657-8450. Res: (703) 620-5995. S: Larae. Job: VP, Gen Mgr, Finnegans, Inc. Svc: USA. Ret: 79. 32 yrs. Past VP, Phantom Corps Chapter.

ZANOFF, John, Jr., (COL) (M64) 36 Cliffwood Circle, North Little Rock, AR 72118. Res: (501) 753-7171. S: Anna Marie. Svc: USA, USMC. Ret: 88. 40 yrs.

ZIEGLER, Jimmy N., (MAJ) (M69) (Ziggy) 3332 North Calle Largo, Tucson, AZ 85715. Dy: (602) 325-9244. Res: (602) 886-0065. S: Christine. Job: Sr. Buyer, CTIO Spt Ofc, Aura, Inc. Svc: USA. Ret: 71. 22 yrs. Past Sr VP, Hanau Chapter.

ZORN, Burl A., (COL) (M60) (Burl) 499 Collins Dr, Springfield, PA 19064. Dy: (215) 591-3429. Res: (215) 328-5125. S: Mary. Job: Dir, Mktg, Middle East, Boeing Hcptrs. Svc: USA. Ret: 84. 26 yrs. Past Pres, Monterey Bay Ch.

ZYWOTOW, Sidney J., (MR.) (M77) (Sid) 276 Pelican Road, Middletown, NJ 07748. Res: (201) 671-5054. S: Bernice.

U.S. Precision Helicopter Team Wants You!

by CW4 E. Daniel Kingsley

FT. RUCKER, AL — The United States Precision Helicopter Team (USPHT) has been approved and funded, and will return in 1989 to Paris, France to defend the World Helicopter Championship title, which we have held since 1981. Lots of things are happening to make this possible, but you need some basic information:

1. The letter of Instruction (LOI) #89-1 (the outline of requirements and rules), is on the street to every Aviation Brigade Commander in the world. If you haven't seen a copy, and you are serious about competing, CALL US. (Autovon 558-3553/3752 or commercial 205-255-3553/3752).

2. This is a total Army effort under the sponsorship of the Helicopter Club of America. In addition, private pilots and businesses are urged and encouraged to compete or to sponsor crews to the USPHT National Competition at Ft. Rucker, 15 thru 21 April 1989. There is not much time, and it cannot be done without your command support.

3. There are several personal qualities essential to achieving a place on the team. It is my opinion that the pilots who win are

CW4 Kingsley is Safety Officer for the U.S. Precision Helicopter Team, USAAVNC, at Fort Rucker, AL.

those who know the rules and have enough practice to have confidence in their abilities.

They must be physically fit, capable of dealing with the stress of the competition and prepared to undergo a serious PT program. You must start NOW if you want to get a place on this Team.

References

There are several good references giving discussion of the 1986 team which you will be well served to research.

1. Aviation Digest, months of February, March, September and October 1986.

2. AAAA Magazine, months of January, February, May and August/September 1986.

We'll have more for you as time goes on, but understand that the Army is serious about getting the best competitors to Fort Rucker for the National Trials this time.

Your aviation chain of command has a letter from MG Parker, USAAVNC commander, personally requesting their support in this effort.

Spread the word. Get your chain of command involved. One of the pilots on this team will be the next World Champion Precision Helicopter Pilot. Why not YOU? IIIII

OH-58D - cont. from p. 18

minutes or less) change of weapons. Chart 1 illustrates how those systems are mounted. With one weapon station on each side, any combination of two weapons can be carried. For close-in targets, .50 cal machine gun and approximately 750 rounds can be mounted on either or both sides. The .50 cal was selected primarily for its lethality. Weapon fires are accurately adjusted using the thermal imaging system, which tracks each bullet out to 2000 meters at night without tracers.

Soft and some hard area targets can be defeated with the HYDRA 70mm rocket. We have been very favorably impressed with the range, accuracy, and lethality of the new family of rockets. The cockpit rocket management systems and remote fuze setter provide very precise fires out to maximum ranges in excess of 5000 meters. The Armed OH-58D can carry a seven-shot pod on either or both sides for a maximum load of 14 rockets with multi-purpose submunition, flechette, smoke, or HE warheads.

HELLFIRE

Two HELLFIRE missiles can be carried on either or both sides for a maximum of four. The OH-58D can fire autonomously or operate as either firing or designating element of a remote engagement. Up to four Air-to-Air Stingers complete the initial weapon system. Although the max gross weight has grown from 4,500 pounds to just under 5,500 pounds, increases in engine horsepower



and transmission limits preserve the sparkling performance of the unarmed aircraft. Since the final configuration of the production aircraft has not been determined, other weapons, such as a 20mm cannon with about 300 rounds, a multi-barrel .50 cal, and a TOW/Mast Mounted Sight Automatic Guidance System, are still being considered.

The addition of the weapons to what has been certified as

convert the recon squadrons and their attack battalions from OH-58A/C and AH-1s to all Armed OH-58Ds. Chart 2 indicates the actual numbers by unit type. I would like to report that production would be immediate, but, unfortunately, I cannot. Due to funding constraints, first production of the Armed OH-58D will probably occur sometime in late FY91.

As you can see, the OH-58D program has been buzzing. It's

ARMED OH-58D FIELDING IMPACTS

| ORGANIZATION | MISSION | TODAY | MODERNIZED |
|------------------------------|---|-------------------------------|-------------------|
| HEAVY AND LIGHT DIVISIONS |  ARMED RECON | 12 OH-58A/C 8 AH-1F 20 | 16 OH-58D (ARMED) |
| REGIMENTAL AVIATION SQUADRON |  ARMED RECON | 27 OH-58A/C 26 AH-1F 53 | 41 OH-58D (ARMED) |
| AIRBORNE AND LIGHT DIVISIONS |  LIGHT ATTACK | 13 OH-58A/C 21 AH-1F 34 | 25 OH-58D (ARMED) |

the most cost and operationally effective scout affords us a real opportunity to help alleviate some of the weaknesses in our air recon troops. The scout can now see the targets at night and deliver lethal ordnance to their maximum range.

The increased capabilities brought about by arming allowed planning for the Armed OH-58D as an interim aircraft to allow modernizing and downsizing to some projected LHX organizations. Priorities will go, based on current planning, to the Armored Cavalry Regiments and Heavy Division air recon troops. Two light divisions, the 82d and 7th ID, will

particularly exciting when you realize that only 12 months ago the program was at the brink of termination. Today we have fielded more than 120 production aircraft and have accumulated nearly 40,000 flight hours at nearly 80 percent FMC. The units are doing a spectacular job, maintaining operational readiness well above the required DA standard and are finding new and innovative tactical application in every training exercise. The program and the Army have come a long way, but as a famous showman once said, "Stick around; you ain't seen nothing yet." Scouts, first in, last out. ■■■■

Combat (continued from page 6)

virtually all combat communications will be digitized, jam resistant, and secured.

Army Aviation is perhaps the largest consumer of intelligence information on the battlefield. Two highly trained aviators control a vehicle which has four communications radios on a platform that usually flies above the height of ground based antenna systems. On board this platform is the equivalent of a 155 mm artillery battery, and an air defense platoon. The aviators are skilled in artillery calls for fire and can dash from one side of the division's front to the other in a matter of minutes. The best way to employ this vehicle is to find targets so it can engage them either by itself, or by calling for close air support, air attack, or artillery. The aircraft's speed, lethality, and vulnerability requires maximum control of its position on the battlefield. Commanders use combat net radios and UHF HAVE QUICK to direct and control in a jamming environment.

Data Required

Such a prodigious fighting machine requires large amounts of data to feed it targets. The pilots can hunt their own targets by using on board acquisitions systems but this is not very efficient. There are a number of other systems that are being fielded soon which can do a much better job. Joint STARS, Forward Area Air Defense, Satellite based systems, and an emerging innovation, Unmanned Aerial Vehicles (UAVs). UAVs can carry sophisticated optical and/or radar systems, fly virtually undetectable at medium altitudes, and cover large areas of the battlefield. All of these sources must communicate their data to a processing facility which nearly instantaneously distributes it to the consumer. These processing facilities can be airborne reconnaissance vehicles or battalion Tactical Operations Centers (TOCs).

There is one other element of C³ combat developments worth mentioning here. None of this instant target distribution happens by magic. Commanders, at all levels possess large amounts of data; all of which requires sorting, filtering, prioritizing, and distribution. The only way to accomplish this is by using automation equipment. Preplanned artillery fires don't come on a "measle sheet" but on a disk. The nightly courier

doesn't deliver your overlay for the next days operation. It's sent via MSE or SINCGARS and printed on your plotter in the TOC or merely put into your Maneuver Control System (MCS) computer. A Data loading cartridge, programmed through a mission planning station, replaces maps and charts.

Combat capabilities of the AH-64 and OH-58D depend directly on the communications structure that supports them. Target hand over via Airborne Target Hand-over System (ATHS) is just the tip of the iceberg in data transfer on the battlefield. These new systems aroused Army aviation's data communications appetite. As data systems proliferate, full exploitation of the communications, navigation, speed, survivability, and lethality of the Army's modern aircraft will improve.

The capabilities of new C³ systems are not without significant challenges however. The "map and pencil" mentality has to become a keyboard literacy. The significant challenges to training in Army Aviation are formidable.

Training

The dramatic emergence of significant numbers of more capable communications systems, challenges commanders to review the way they do business. Army Aviation will be seeing a number of computers at battalion and brigade level: Commanders Tactical Terminal (CTT), Unit Level Logistics System (ULLS) computer, Maneuver Control System (MCS) computer, and Aircraft Mission Planning Station (AMPS) computer to name a few.

These systems will be connected to data distribution systems such as Joint Tactical Information Distribution System (JTIDS), Enhanced Position Location and Reporting System (EPLRS), and Single Channel Ground and Airborne Radio System (SINCGARS). How do we take the next step and interface the battalion/brigade staff to these machines? It is a big task to change the way staffs have been doing business for years.

Many of us can remember doing overlay after overlay late into the night. Distribution to the company commanders was made early in the morning, who in turn had minimal time to come up with their own plan of action to execute the mission. Eventually, three or four days into the exercise, everyone was familiar with the terrain, and the commander's intent, and could perform the

subsequent phases of the operation in what is called the "push-to-talk" mode. There was little intelligence information, just an intuitive sense of what the Opposing Force was going to do next. With new data systems "push-to-talk" no longer means giving up vital intelligence, leaving Forward Area Rearm/Refuel Points (FARRPS) in one place for extended periods, hunting for targets, etc. It means updated information is passed instantly to the manager who needs it.

Control of battle elements is aided tremendously by these systems. In order to take full advantage of them however, staff officers have to trade in their grease pencils for keyboards, and maps for display monitors. This will be a gradual change due to the moderate rate in which these new systems will be introduced. This change should be easier for the younger officers and NCOs, who were brought up on computers. Military academies, basic courses, and advanced courses all require some level of computer literacy and use computers for certain portions of their programs. It is the battalion commander/sergeant major age group, brought up on the grease pencil and overlay, that has the most difficulty adapting.

Automation Age

The first major revelation of the emergence of the automation age was the elimination of signal personnel in the company and battalion. The theory is "user owned/user operated". New signal equipment is easy to use and seldom needs repair. Radios, antennas, COMSEC, and telephones are installed by the users now. The Improved High Frequency Radio (IHFR) sets up easily and tunes at the press of a button. Signal officers are no longer in Aviation battalions. The battalion commander no longer can turn to him and get an explanation about ionospheric depletion causing his HF link to degrade when the sun goes down. Aviation warrant officers are having to inventory OE-254 antennas and set fill devices for COMSEC on their own.

Aviation personnel are being forced into the automation age. When the battalion 52 calls the brigade artillery liaison officer for the list of pre-planned fire points and gets an answer such as "I'll send it over MSE to your MCS", the S2 better know how to get what he needs from the maneuver control computer. The conse-

quences, no "measle sheet" for his subordinate elements, are not acceptable. The ability of the American soldier to adapt to the changing way of doing business under the Army of Excellence (AOE) is no different from what we ask our soldiers to do every day in a combat situation: adjust, adapt, innovate. Institutional courses of instruction must do the same thing. Quickly adjust to the changing tide of automation equipment being fielded which dramatically increases our ability to control maneuver elements.

Geographic location presents another interesting training challenge with respect to the new communications systems that are being fielded. Central processing facilities for JTIDS and EPLRS are at Corps level. This means that to do systems training, corps assets are going to have to be tasked to provide support.

This is a significant problem for the 101st Airborne Division (Air Assault), 24th Infantry Division (Mechanized) and other division and separate brigades that are not collocated with their Corps. For example: It was interesting to observe how all the III Corps divisions at Ft. Hood use Corps Communications Electronic Warfare Intelligence (CEWI) assets to gain a better picture of Opposing Force (OPFOR) order of battle.

A division like the 101st Airborne Division (Air Assault) at Ft. Campbell, Ky, not having the same habitual working relationship with XVIII Airborne Corps assets located at Ft. Bragg, NC, used different methods of intelligence gathering (more reconnaissance flights). This expended more flight hours and did not achieve the same level of OPFOR order of battle information. Further, target acquisition sensors that feed JTIDS are mostly Air Force and Navy owned and operated. EPLRS relies on divisional air defense units to acquire target locations. Unit location anomalies such as these will have to be overcome.

JTIDS and EPLRS are vital for expert command and control of Airland battle assets. Without these assets, and habitual training with them, Army Aviation reverts back to the hunter mode. This is a very inefficient way to employ precious men and machines. C³ training then is a formidable task. If Army Aviation is to employ its assets to maximize combat effectiveness, every automation tool must be used to peak efficiency. ■■■■

Integrated (continued from page 7)

there are other benefits from hooking up all those boxes together: They can now exchange information among themselves or with other systems (like the target acquisition system) without going through the pilot, who has plenty of other things to do.

In the AHS APACHE, the scout can send target coordinates over a radio to the APACHE using AHS, and the coordinates can be automatically transferred within the APACHE to the Target Acquisition-Designation System (TADS), which can automatically point the sight at the target. System integration can do some interesting things, can't it?

But as good as putting the avionics on a bus is, we are still left with the problem of single point failures in the boxes. They are still separate systems, with separate power supplies, transmitters, receivers, processors, etc. When one of these suffers damage or fails, the function of that black box is lost. Again, so what do we do about it?

Obvious Advantages

Suppose we gather one whole set of avionics together and put them all into one box. A set like communications, navigation and identification (IFF). Immediately obvious are advantages like needing only one (very reliable) power supply instead of seven or more individual black box power supplies.

But there is another, much more important advantage. It is now possible to build transmitters and receivers that cover much more of the spectrum than just FM or UHF, and they can operate on either AM or FM.

Suppose we include one broad band receiver module and one broad band transmitter module for each band we have to listen and talk on in this new system. Then if one quits we could use another, couldn't we?

The concept is to build a system using general purpose modules as much as possible, controlling those modules with a computer to make the system very flexible and robust in case of failure. If you lose the module operating as your UHF transmitter, the computer tells another (like the one acting as the VHF-AM

transmitter) that it's now UHF, and the message isn't even perceptively delayed. The priority functions remain full time (like the scout-attack AHS link), and you still could do the lower priority functions by diverting some modules momentarily (say to make a quick call on a VHF-AM net). The mission reliability gains would be tremendous.

Controlling advanced modules with a smart computer has other advantages, too, like flexibility. If we design a series of modules for functions like transmitter, receiver, signal processor, etc., we could then tailor one of these systems for another aircraft simply by changing the assortment of modules in the box. It could be something like going down the rows of a super-market choosing the modules we need for a particular type of aircraft, creating a custom system from standard modules.

We could also control the modules we have installed in different ways. There is a new joint system under development for locating downed aircrews called the Personnel Locator System (PLS). This aircraft function could be added to our new integrated box just by reprogramming the control computer. In other words, we could add some new functions without adding more black boxes or even modules just by controlling the modules differently.

ICNIA

The name for this new joint service development of an Integrated Communications, Navigation, Identification Avionics system we have been discussing is, not surprisingly, ICNIA. The Army's Advanced Development Model of the ICNIA is scheduled to fly in late 1989. We intend to use ICNIA, or some similar system, in the LHX. The ICNIA will also be used on the Air Force's new Advanced Tactical Fighter and is under consideration for the Navy's new Advanced Tactical Aircraft, the A-12.

Obviously the final ICNIA-type systems for these three very different aircraft will be somewhat different. But if all three services agree on standard modules, standard connectors, standard backplanes and bus protocols, and standard dimensions for the elements of the box to mount them in, we will be able to fill a box with the modules we need for each

aircraft and save a lot of money through standardization.

In the LHX, all of the electronics are being designed as a group, called the Mission Equipment Package (MEP), which will include comm, nav, ident, and EW systems, as well as target acquisition and fire control, the digital map, flight controls, automatic status monitoring and reporting system, and the Very High Speed Integrated Circuit (VHSIC) central computer. All of these systems will be integrated in the LHX as much as the state of the art allows. We will also be using portions of this MEP on other aircraft wherever we can.

Future Aircraft

For aircraft even farther in the future, we will be working toward greater integration. We can imagine a time when son of LHX will come around a hill, encounter an unexpected enemy air defense weapon, and *really* integrated systems would go to work. The target acquisition systems would work together to locate and identify the target, showing the pilot a magnified view of it in perspective position. The gun would point at the target and a fire control solution would start, in case it is needed.

The flight control system would turn the aircraft toward the nearest terrain feature from the digital map that would break line of sight (the pilot could override with one movement of the stick). The aircraft survivability equipment would jam or eject chaff or flares as appropriate, and the fire control system would select the gun or correct missile based on range and target type, which the pilot could fire just by squeezing the trigger.

In other words, the pilot could be presented with recommended alternatives — good options, not just raw data — and therefore make very quick, intelligent choices. On the fast-paced battlefield of the future, if the pilot has to figure out the meaning of raw data before he can act, it may be too late.

Integration of avionics and the MEP will give us several advantages — less control heads, much higher reliability, mission and function flexibility, and passing information directly among systems. But ultimately it will give us an aircraft-pilot team that can react very intelligently and very quickly to do the job a lot better — and survive a lot better too. ■■■■

USASAM

(continued from page 14)

aeromedical training for psychologists stationed at locations with large aviation assets. Long range plans include the acquisitions of a new, dedicated academic training facility, a tower to conduct rescue hoist procedural training from, and a spatial orientation training facility. This facility will have five computer driven training devices with a full three axes of motion. Each device will be capable of simulating all known vestibular illusions of flight in a safe simulator environment.

Evolving doctrine, new equipment, and well motivated soldiers have provided USASAM the ability to meet the training mission with innovative thinking and problem solving. ■■■■

NET

(continued from page 15)

varies from the type of training to be presented to classrooms, audio visual aids, prerequisites for courses, course material, course length, tools and test equipment, class hours, aircraft flying hours, and anything that may impact the unit or quality of training presented.

Once the training dates are finalized, the service schools' instructors are notified and funds are transferred for their travels. The NET manager does all the final coordination for lodging, fund transfer, and clearances. He monitors the students once training starts and ensures that quality instructions are being presented as outlined in lesson plans. The NET manager ensures all required training aids are shipped and available for instructors.

Currently AVSCOM NET manages over 40 NETPs. These vary from the CH-47D, EH-60A, MH-60K, LHX, and flight simulators, to other systems like the Aviation Ground Power Unit, Extended Range Fuel System, Infrared Suppressor System, Cockpit Procedures Trainers, and many other aircraft related systems. NET managed a budget of over \$500K in FY88 for just NETT and training development.

As can be seen in this brief look at NET and its many tasks, NET is a very important player in the team that fields a new system or support equipment. ■■■■

C31 (continued from page 3)

back to Congress by April of 1989. There are good arguments both for and against the division of these functions, and it is not yet clear which arguments will win out or precisely how either alternative will affect Army Aviation. I merely wanted to report to you on these matters before giving you an overview of recent C³I developments within Army Aviation.

Since Aviation is the most mobile and maneuverable of the Army branches, it is of utmost importance that its C³I systems be extremely responsive. C³I systems in Army Aviation may be divided into two categories, ground systems and airborne systems. The ground-based systems are used to interface with other services, branches, or Aviation ground commands. The airborne systems are used primarily within the Army Aviation Branch.

ATCCS

Within the ground system category, Army Aviation interfaces with other branches primarily through Army Tactical Command and Control System (ATCCS), commonly referred to as Sigma Star. The fielding of this multifaceted system began in FY87, and the process is scheduled to be virtually completed by FY93.

Army Aviation brigade and battalion command posts will receive information from each Battlefield Functional Area (BFA) of the Sigma Star, i.e., from various common elements of the ATCCS, but they will interface with other branches primarily through the Maneuver BFA via the Maneuver Control System.

Army Aviation's C³I architecture also includes a conceptual brigade and battalion level command post requirement that is unique to Aviation. This is intended to provide tactical commanders the agility, initiative, depth, and synchronization necessary to make sound and timely decisions and to rapidly direct the activities of subordinates and supporting units on the airland battlefield.

The heart of this requirement is the automated mission planning station (AMPS) at the brigade and battalion level command post. Upon receiving intelligence from other members of the combined arms team, the brigade and battalion com-

manders use the AMPS to plan the mission and then to communicate the mission plan to aircraft or other subordinate elements.

It is through the aviation command post that the ground system ties into the airborne system in recent C³I developments and plans. According to plans developed at USAAVNC in 1988, it is expected that each brigade and battalion will be provided with one AMPS. From the AMPS, the C³I interface with individual pilots will be either hand-delivered on disc or cartridge or sent via HAVEQUICK or the single channel ground and airborne system (SINGGARS), using the Airborne Target Hand-over System (ATHS) or some similar modem and transmission medium.

HAVEQUICK provides an improved near-term, air-to-air, air-to-ground, jam resistant, UHF-AM voice communication capability for the AN/ARC-164 aircraft radio. HAVEQUICK equipped radios were introduced in production line aircraft in 1984. Radios produced after July 1986 incorporated an improved model, HAVEQUICK II, which was compatible with the earlier one. Aircraft produced prior to 1984 which have not undergone significant avionics modifications do not have radios that are compatible with HAVEQUICK, but action has been initiated to replace existing non-compatible UHF-AM radios in all currently used aircraft.

SINGGARS is a family of radios which are planned to be the replacements for all existing VHF-FM radios. The single most outstanding feature of SINGGARS is its frequency-hopping electronic counter countermeasure capability. The new SINGGARS radios are required to fit the same footprint (mechanical) as the existing VHF-FM radios. The airborne fielding of SINGGARS is scheduled to begin in June 1989.

The ATHS, a data modem capable of operation with the HAVEQUICK and SINGGARS, was developed under a letter of agreement approved in May 1980. The need for the system was identified during the development of the HELLFIRE missile system and the artillery ordinance COPPERHEAD in order to reduce the radio transmission time required for handing off target information during scout and attack helicopters and field artillery units.

The ATHS is a line replaceable unit which interfaces the target acquisition sensors, weapons systems, aircraft displays, navigation systems, and the communications systems on scout and

attack helicopters. It provides pre-formatted and free text messages for burst transmission via the onboard communications system and compatible-with-artillery tactical fire direction system. Previous testing has proved the ATHS to be operationally successful, and USAAVNC supports continued plans to field the system.

Finally, the USAAVNC has developed plans for the ATHS and Avionics Integration (AI) modification of all AH-64s currently scheduled for production. The ATHS-AI modification involves the addition of equipment that will control the flow of information throughout the avionics systems and to and from the fire control computer. The ATHS-AI will be controlled by the control display system. Data related to target engagements that are received from OH-58Ds will be delivered directly to the fire control computer. In addition, this improved ATHS will be able to interface with other

systems for air-to-air engagements. There will be adequate FM radio power to ensure communications on the battlefield, and the interface with SINCGARS will provide frequency-hopping radios for command and control and target handover requirements. The data transfer system will be installed to provide for bulk loading of mission data on discs or cartridges, and software programs will be provided for use with the Army standard tactical computers to ensure compatibility.

Prototype models with the above-described equipment installed are scheduled for delivery in FY90. In this, as well as other C¹ systems, Army Aviation has made a concentrated effort to utilize standard DOD hardware so as to enhance interservice interoperability. Significant progress in this area has been and continues to be made — especially between the Army and the Air Force — but we still have challenges ahead. ■■■■

CAREER TRACK

If you'd like to take advantage of the Career Track employment referral service, but you're not yet a member of AAAA, the solution is simple: Just fill out a membership form and send it in along with your request for a Career Track application. Your ad will run in the next available issue.

Active AAAA members may have a 30-word classified employment ad published in two consecutive issues of ARMY AVIATION MAGAZINE free of charge. Write to the AAAA National Office, 49 Richmondville Avenue, Westport, CT 06880-2000, or call (203) 226-8184 for Career Track applications.

Corporate Flying Job Hunting. ATP Multi. Commercial Airplane Single Engine. Rotorcraft - Helicopter. Instrument - Airplane and Helicopter. Certified Flight Instructor, Airplane, Instrument, Multi, Rotorcraft - Helicopter. BS, Aviation Management. 12-01

Captain, Army Aviator with B.S. degree. Nine years experience in aircraft maintenance. 1,500 hours flight time, rated in the UH1-H, CH-47 and maintenance test pilot in the UH1-H aircraft. 12-02

Seeking position in Marketing/Business Development. 24 years experience marketing Avionics/Communications equipment to U.S. DoD. HF Radio a specialty. Will travel and relocate. 12-03

Master Aviator, retired Oct 88, B.S. Aerospace Management, Fixed/Rotary Wing Qualified, Extensive Command, Air Cav, Aviation R & D, Topo Mapping, and Terrain Analysis experience. Seeking employment in Business Development or Project Management role. 12-04

Master Army Aviator, MBA. Combat Developments, RDT&E, PPBES, Project Management background. Current in LHX, Army Aviation Master Plan requirements. Current Pentagon, recent AMC assignments. Seeking Business Development, R&D, Marketing/Representative position. 12-05

BRIEFINGS



MG Ellis D. Parker (left), commanding general of Fort Rucker, AL, presents the U.S. Army Superior Unit Award to the commander of the **1st Battalion, 212th Aviation Regiment, Aviation Training Brigade**, LTC **Steven F. Rausch**. The award was presented in recognition of the battalion logging 155,942 accident-free flying hours during calendar year 1987 with no Class A, B or C accidents. On the day of presentation, the battalion had more than 226,000 accident-free hours; an all-time Army Aviation record.

October 1, 1988, the Aviation Branch received pro-penency for aviation logistics from the Transportation Corps. **The Army Aviation Logistics**

School (USAALS) will remain at Ft. Eustis, VA as a tenant activity. Its commander is **COL Thomas M. Walker**. No moves of personnel, equipment or facilities to Ft. Rucker will occur.

VECTOR Research, Inc. and **Sikorsky Aircraft**, have received 18-month contracts from the U.S. **Army Aviation Research and Technology Activity's Aviation Applied Technology Directorate (AATD)**, Ft. Eustis, VA to conduct a preliminary investigation into Army airlift needs leading to the design of **Advanced Vertical Take-off and Landing Cargo Aircraft**. "The air vehicle having an increased capacity and range is to replace the present CH-47 Chinook helicopters," said **Gordon T. Galow**, AATD project engineer.

Fort Rucker has been named best medium-size installation for Fiscal Year (FY) 88 in the Installation of Excellence program conducted by the U.S. **Army Training and Doctrine Command (TRADOC)**. Fort Rucker earned the same title for FY85 and 86. The award is based on first-hand observations by a traveling TRADOC team that surveys each of the command's 16 installations each year.

AWARDS AND HONORS

The following information is provided by the U.S. Army Aviation Center at Ft. Rucker, AL:

Initial Entry Rotary Wing Aviator Course Class 88-6 (9/21/88): 2LT Richard T. Fugate, Distinguished Graduate; 2LTs James L. Parker, Samuel E. Lamb, Michael F. Gajewski, Stephen M. Shea, Honor Graduates.

Initial Entry Rotary Wing Aviator Course Class 88-6 (9/21/88): WO Edward A. Bass, Distinguished Graduate and Class Leader; WOs Christian J. Chandler, Steven C. O'Berg, Carlton L. Beahm, James M. Ertsgard, Honor Graduates.

Initial Entry Rotary Wing Aviator Course Class 88-7 (10/5/88): 2LT Mark A. Parrish, Distinguished Graduate; 2LTs Paul K. Riest, Robert A. Hyland, Monte C. Ferguson, Michael G. Wiedmaier, Honor Graduates.

Initial Entry Rotary Wing Aviator Course Class 88-7 (10/5/88): WO Robert A. Young II, Distinguished Graduate; WOs Richard K. Metcalf, Terry W. Talbott, James E. Legaspi, Thomas B. Palenske, Honor Graduates.

Initial Entry Rotary Wing Aviator Course Class 88-8 (10/21/88): 2LT Michael J. Blatz, Distinguished Graduate; 2LTs Daniel H. Howett, Dale N. Johnson, Michael J. Francesconi, Gregg J. Cicchetto, Honor Graduates.

Initial Entry Rotary Wing Aviator Course Class 88-8 (10/21/88): WO Gregory A. Dobbs, Distinguished Graduate;

WOs Kenneth W. Pickdesimer, Christopher W. Humphreys, Martin E. Brannan, Anthony Mocerino, Honor Graduates.

Initial Entry Rotary Wing Aviator Course Class 88-9 (11/4/88): 2LT James E. Lutz, Jr., Distinguished Graduate; 2LTs Dennis A. K. Fox, William T. Hopson, Todd T. Cook, Mark Bakum, Honor Graduates.

Initial Entry Rotary Wing Aviator Course Class 88-9 (11/4/88): WO David E. Guido, Distinguished Graduate and Leadership Award; WOs James A. Herzog, Steven E. Hiles, Kevin L. Bender, Charles Johnson, Honor Graduates.

Air Traffic Control Advanced Noncommissioned Officer Course Class 88-5 (9/23/88): SFC William H. Feeney, Jr., Distinguished Graduate.

Flight Operations Advanced Noncommissioned Officer Course Class 88-5 (9/23/88): SFC Gale A. Miller, Distinguished Graduate.

Air Traffic Control Basic Noncommissioned Officer Class 89-1 (10/28/88): SGT Freddie Johnson, III, Dist. Graduate.

Flight Operations Basic Noncommissioned Officer Course, Class 89-1 (10/28/88): SGT Barry A. Adderhold, Distinguished Graduate.



Lt. Colonels

BRANHAM, TERRY W.
1410 HOLDRIDGE TERRACE
WAYZATA, MN 55391

CLAYLAND, ROBERT J.
16307 EAST COURSE DRIVE
TAMPA, FL 33624

COOK, STEPHEN K.
9063B BASSETT STREET
FORT DRUM, NY 13603

DEASON, EMORY N.
1941 WRIGHTS WAY
JONESBORO, GA 30236

GLASS, CHARLES W.
7927 S. WEST 104TH ST.
APT E-205
MIAMI, FL 33156

HETHCOX, RICHARD E.
601 GARAMOND PLACE
PEACHTREE CITY, GA 30269

HIATT, RALPH J.W.K.
1ST BATTALION
10TH AVIATION REGIMENT
FORT RUCKER, AL 36362

JONAS, LARRY M.
3703 ROXBURY LANE
ALEXANDRIA, VA 22309

MAY, JOHN W.
113 LIVEOAK ROAD
ENTERPRISE, AL 36330

MEDVITZ, CHARLES M.
977 HERMES AVENUE
ENCINITAS, CA 92024

MEOLA, MARIO
DIR. EVAL. & STANDARD.
PO. BOX 434
FORT RUCKER, AL 36362

MITCHELL, BRYAN D.
2316 S. PATTERSON DRIVE
MESA, AZ 85202

MYERS, ANTHONY E.
13819 DELANEY ROAD
WOODBRIDGE, VA 22193

ROBINSON, RUSSELL N.
US ROAD STANDARD, GP
AMERICAN EMBASSY, BOX 165
APO NEW YORK 09680

SALTNES, GERALD
4TH BN 229TH ATK HCPTA
APO NEW YORK 09140

Majors

ACCINELLI, STEVEN R.
9058A BASSETT STREET
FORT DRUM, NY 13603

ALLEN, DANIEL K.
500 NORTH 2ND STREET
BURLINGTON, KS 66839

BRENDSSEL, MARLIN D.
JAMES A. HALEY VET. HOS.
13000 BRUCE DOWNS BLVD
TAMPA, FL 33612

CROWLEY, JOHN S.
100 A.M. WINDHAM DRIVE
APT. 705
DALEVILLE, AL 36322

GARRETT, PAUL F., JR.
31 BUCKNER DRIVE
FORT LYNWORTH, KS 66027

GRIFFITH, ROLAND D.
5170 BONG AVENUE
BELTONT, MO 64012

HOLTZ, BRADFORD J.
7712 JEWELWEED COURT
SPRINGFIELD, VA 22162

KULIK, JOSEPH S.
115 WOODCHUCK COURT
ELLENWOOD, GA 30049

KURRS, ROBERT V.
10TH FSU
APO NEW YORK 09279

LAACK, DAVID E.
1808 PLEASANT LANE
COPPERAS COVE, TX 78522

LAWSON, JAMES E., II
95-475 LAUPALAI PLACE
MILILANI, HI 96789

LENNON, BERT L.
228 POLARIS
WHITE SANDS MR, NM 88002

LUCAS, JOHN F.
207 SHEFFIELD LANE
TARR, VA 23666

MARCHIONY, PETER A., JR.
APO EMBASSY, COSTA RICA
APO MIAMI 34020

SLICK, DOUGLAS S.
9603 BAILWEATHER CIRCLE
HUNTSVILLE, AL 35803

STINSON, KATHERINE D.
HHD 207TH MI BRIGADE
APO NEW YORK 09279

STRANG, MICHAEL J.
379 ARDENNES CIRCLE
FORT ORD, CA 93041

SUMNER, HERMAN W.
HQ 4TH BATTALION
229TH AHB REGT.
APO NEW YORK 09140

YARBROUGH, HOUSTON A.
1109 BESSEMER ROAD
HUNTSVILLE, AL 35816

Captains

ABRANTES, GEORGE F.
5521 LIMERICK CIRCLE
APT. 12
WILMINGTON, DE 19808

ALDSTADT, BRYANT H.
628 WOOD STREET
CALIFORNIA, PA 15419

BOURNE, WILLIAM B.
59 ENDLE AVENUE
FORT RUCKER, AL 36362

BOWLER, LYNN N.
D COMPANY
1-14 AVIATION
FORT RUCKER, AL 36362

BOWMAN, ROBERT E.
1700 BOBBY LEE DRIVE
KILLEEN, TX 76543

BURNS, JOHN
202 CHOCTAW DRIVE
ENTERPRISE, AL 36330

DAVIS, ROBERT L., JR.
ENGLISH VILAGE APT.,
NUMBER 78-5
NORTH WALES, PA 19454

DAVIS, SHANNON B.
D COMPANY, 1-14 AVIATION
FORT RUCKER, AL 36362

DINAPOLI, JOHN
75 DOE COURT
S. BRUNSWICK, NJ 08852

DISNEY, PAUL R., JR.
UNIV. OF COLORADO
WINN 52
COLORADO SPS, CO 80907

EIBLER, RICHARD K.
930 ELTON HALL CIRCLE
NEWPORT NEWS, VA 23602

ENDERLE, RICHARD A.
PO. BOX 2237
FORT CAMPBELL, KY 42223

GAETJEN, JAMES T.
5725-2 FRISBEE ST STREET
FORT HOOD, TX 76544

GOLDSBERRY, DALE A.
203 WILDWOOD DRIVE
ENTERPRISE, AL 36330

HARTER, ROBERT L.
6857 BRASSWOOD DRIVE
FAVETVILLE, NC 28314

JONES, WILLIAM R.
HHC, 4TH BRIGADE
PO. BOX 67
APO NEW YORK 09182

KUMAR, SANJAI
95-107 LALAI PLACE
MILILANI, HI 96789

LEWIS, STEVE A.
C TRP, 5/6 CAV.
12TH AVIATION BRIGADE
APO NEW YORK 09457

MACCHIARELLA, NICKOLAS
D TROOP, 4-4 CAV.
BOX 137
APO NEW YORK 09702

MINADEO, GARY A.
62 ENDL AVENUE
FORT RUCKER, AL 36362

MOORE, BRUCE
PO. BOX 5690
FORT HOOD, TX 76544

NEILSON, ROBERT D.
PO. BOX 3847
FORT STEWART, GA 31314

PRESTRIDGE, GEORGE N.
104 AUSTIN LOOP
D BENNING, GA 31905

REAVES, EUGENE W. IV
SFTS DET, UASSB
APO NEW YORK 09165

REICHHARDT, RICHARD A.
59 EAST HARRIS
FORT RUCKER, AL 36362

ROTH, BARRY A.
307 CHICKSAW ROAD
ENTERPRISE, AL 36330

SANHUEZA, HUGO S.
5218 WEST NIGHTHAWK WAY
TUCSON, AZ 85741

SEWELL, ROBERT D.
105 PATRICIA LANE
DALEVILLE, AL 36322

SMITH, STEPHEN C.
25 LOGAN
FOART RUCKER, AL 36362

STAUGAARD, JOHN C.
SO. CALIF VP NG AFRS
23430 VIA JARDIN
CALIFORNIA, CA 91355

SUTLIFF, KEVIN M.
1048 KINGSTON COURT
VERNON HILLS, IL 60061

THOME, MICHAEL N.
D COMPANY
1-14 AVIATION
FORT RUCKER, AL 36362

TRANG, JEFFREY A.
2503 TORTOISE LANE
KILLEEN, TX 76542

WHATLEY, VINCENT R.
HHC, 4/159TH AVN REGT
BOX 615
APO NEW YORK 09359

WILHELM, BRUCE A.
1600 BAY RIDGE ROAD
EDGEWATER, MD 21037

WOLFE, DANIEL G.
416 GRAND PINE AVENUE
ENTERPRISE, AL 36330

ZAHRT, FRANK H.
104 ALBURN DRIVE
WAYNESVILLE, MO 65583

1st Lieutenants

BEAMAN, PATRICK L.
505 BRIARWOOD
APT. 1
ENTERPRISE, AL 36330

CERNEY, KENNETH A.
27 KIRBY STREET
FORT RUCKER, AL 36362

CUMBEY, GARY W.
12975 RESERVATION ROAD
SAFARI, CA 93501

GETMAN, PAUL L.
2801 FIELDSTONE DRIVE
KILLEEN, TX 76542

HOLMAN, MARK L.
95-887 MAKUANULUA ST
MILILANI, HI 96789

MCCLURE, BILL W.
402 JONE STREET
VAN BUREN, AR 72956

MELIA, GARRY R.
9126 MAIN STREET
BOX 206, APT. 2
WESTERVILLE, NY 13486

MOONEY, WILLIAM K.
1436-B WERNER PARK
FORT CAMPBELL, KY 42223

PARRISH, MICHAEL D.
1103 ROSEBROOK DRIVE
CLARKSVILLE, TN 37042

POPPIE, JOHN P.
3815A COLLIER STREET
WAHIAWA, HI 96786

ROSE, LEE E.
1419-A WERNER PARK
FORT CAMPBELL, KY 42223

SENTERS, MICHAEL
130-J WEST OXFORD DRIVE
CLARKSVILLE, TN 37042

2nd Lieutenants

ARMSTEAD, ALBERT, JR.
100 A.M. WINDHAM DR, #404
DALEVILLE, AL 36322

CALVIN, GREGORY R.
HHC 52 AVN. BN.
APO SAN FRANCISCO 96301

CHAPMAN, DAVID P.
134-B GUNTER LANE
ENTERPRISE, AL 36330

ENGLING, TIMOTHY J.
201 EAST EMERALD
ENTERPRISE, AL 36330

FISH, CHARLES A.
17825 SPANISH CANYON LN
ANDERSON, CA 96007

HOPKINS, WENDI D.
108A ANTHONY CIRCLE
ENTERPRISE, AL 36330

HUBER, FRANZ J.
CAMELOT VILLA, NO. 26
ENTERPRISE, AL 36330

OLSON, KEITH E.
605 BRIARWOOD
APT. M3
ENTERPRISE, AL 36330

CW4s

CHAREST, DONALD S.
201ST AHC
APO SAN FRANCISCO 96271

CLAYTON, JOHN STEELE
1148 104TH DRIVE, S.E.
LAKE STEVENS, WA 98258

CONRAD, RALPH W.
56 BROADWAY
HAGERSTOWN, MD 21740

GILMAN, TOMMY L.
345 LOCKERT PLACE
CLARKSVILLE, TN 37043

KRAAY, ANTHONY G.
D COMPANY
1-14 AVIATION
FORT RUCKER, AL 36362

MCNEAL, ROBERT A.
D COMPANY
1-14 AVIATION
FORT RUCKER, AL 36362

MONETTE, ROBERT J.
D COMPANY
1-14 AVIATION
FORT RUCKER, AL 36362

ROSE, VICTOR L.
5606 BLYTHEWOOD LANE
FAYETTEVILLE, NC 28311

SHIRLEY, JERRY D.
3355 BRUNSWICK DRIVE
COLORADO SPGS, CO 80920

VAN KEUREN, NATHAN B.
A COMPANY
4/229TH AMR
APO NEW YORK 09140

WEST, CHARLES E.
G CO, 1ST AVN REGT.
BOX 3023
APO NY 09250

CW3s

AMMON, MARK W.
D COMPANY
1-14 AVIATION
FORT RUCKER, AL 36362

BRECKONS, SANFORD D.
D COMPANY
1-14 AVIATION
FORT RUCKER, AL 36362

HARFORD, JEFFREY A.
D COMPANY
1-14 AVIATION
FORT RUCKER, AL 36362

KELLER, GREGORY W.
19 JOHNSON STREET
FORT RUCKER, AL 36362

KRANZ, WILLIAM E.
STUTTGART CHAP VP MEMB
4TH BN, 159TH AVN. REGT.
APO NEW YORK 09359

MERRILL, FRED M., II
B CO, 2/501ST AVN. REGT.
BOX 8-36
APO SF 96271

MOLTENBERRY, JOHN S.
507 BRIARWOOD DRIVE
APT. 128
ENTERPRISE, AL 36330

MORING, RONALD C.
D COMPANY
1-14 AVIATION
FORT RUCKER, AL 36362

PICKETT, JACK
B CO, 3/3 AVN. REGT.
BOX 145
APO NEW YORK 09182

RILEY, WALTER E.
239TH AVIATION COMPANY
APO SAN FRANCISCO 96271

SCHNEIDER, CHARLES E.
MG CO, 3RD AVN. REGT.
BOX 55
APO NEW YORK 09182

SULLIVAN, GARLAND T.
D COMPANY, 1-14 AVIATION
FORT RUCKER, AL 36362

SULLIVAN, JOHN L.
205 W. MONTGOMERY CRS
APT. 1408
SAVANNAH, GA 31408

THORPE, RICKI K.
AVIATION COMPANY
LSUJNFO
APO NEW YORK 09579

WHEELER, BUO W.
1029 DOGWOOD STREET
NO. 8
FORT WAINWRIGHT, AK 99703

CW2s

ELLIS, DANIEL R.
A COMPANY
4-229 AAHR
APO NEW YORK 09140

GOODALL, GREGORY
A CO, 97TH GENERAL HOSP.
APO NY 09757

STATHAM, STACY
8005-A GENERAL GRANT DR.
FORT DRUM, NY 13603

WADE, WILLIAM H.
152 NORTH HARRIS DRIVE
FORT RUCKER, AL 36362

WO1s

HARRIS, JOHN M.
SOUTH JOHNSBURG ROAD
JOHNSBURG, NY 12943

MAUTER, WILLIAM
HHC, 498TH SUPPORT BN.
BOX 245
APO NEW YORK 09355

MEDER, PEGGY L.
2014 HIGHLAND AVENUE
EVERETT, WA 98201

SCHUETZLER, JAMES C.
A CO, 5/158 AVN. REGT.
BOX 823
APO NEW YORK 09039

WOC

HURFORD, ANDREA J.
CMR 2, BOX 13255
FORT RUCKER, AL 36362

KATONKA, PETER F.
614 STRINGER STREET
APT. 233
KILLEEN, TX 76541

Enlisted

HORTON, GLENN A, E4
227 JUNIPER DRIVE
ARLINGTON, TX 76018

HOUSTON, JEFFERY A. PFC
A CO, 8/158TH AVN REGT
BOX 982
APO NEW YORK 09457

JOHNSTON, BECKY L. SGT
214 MEDICAL DETACHMENT
APO MIAMI 34005

McNABB, JIMMY L. MSG
4009 602ND ST, APT. 1
FORT WAINWRIGHT, AK 99703

NELSON, MARK L. SGT
120-J RIVER MEWS DRIVE
NEWPORT NEWS, VA 23602

SLADE, JIM W. E4
1 BOX 7, 1897 SHERRI CRIL
WEST PALM BCH, FL 33406

STREB, SCOTT J. SPC
4100 LAKE RD, APT. 206
KILLEEN, TX 76543

TARSIJA, MICHAEL J. SGT
13507 S.E. STARK
PORTLAND, OR 97233

Civilian

ANDREWS, FRANK J.
5200 SPRINGFIELD PIKE
PO. BOX 31108, STE 119
DAYTON, OH 45431

BAKER, CHARLES C.
713 MORNINGSIDE DRIVE
NOLANVILLE, TX 76559

BELTE, DAUMANTS
PO. BOX 1332
ROSBANDON, CA 93560

DIMARCO, DENNIS J.
304 S. NEW ARMORE AVE
BROOMALL, PA 19008

ESSNER, RONALD
CLIFTON PRECISION, ILSO
HICKORY GROVE RD.
BOX 4508
DAVENPORT, IA 52808

GODAR, OUSAN H.
AGUSTA AVIATION CORP.
3050 RED LION ROAD
PHILADELPHIA, PA 19114

MEANEY, EDWARD J.
21237 S. WALON, SPACE 154
CARSON, CA 90745

PRICE, RICHARD R.
1 ENTERPRISE PARKWAY
NO. 215
HAMPTON, VA 23666

REESE, ALFRED G.
PO. BOX 679
FLORISSANT, MO 63032

SHAIN, ROBERT G.
AGUSTA AVIATION CORP.
3050 RED LION ROAD
PHILADELPHIA, PA 19114

STAGGS, WILLIAM D.
6207 MAUREN LANE
PO. BOX 1959
MOORPARK, CA 93021

WILLIAMS, CHARLES R.
4082 MAGNOLIA PLACE
ST. LOUIS, MO 63110

Retired

COREY, ROBERT R. COL
FORMER NAT'L BOARD MEM
29 SOUTHALL LANDING
HAMPTON, VA 23664

HOLDER, LARRY G. LTC
2412 CALF RUN DRIVE
WILMINGTON, DE 19808

LACY, JOSEPH A. MAJ
1741 E. LAHABRA BLVD.
NO. 21
LA HABRA, CA 90631

LINDQUIST, OLOF G. MR.
4809 S.W. 315TH PLACE
FEDERAL WAY, WA 98023

MERCADANTE, JOHN F. LTC
7208 NW WILLOW CRK DR.
LAWTON, OK 73505

SARKO, JOHN S. LTC
708 JUDITH COURT
WEST BEND, WI 53095

| ARMY AVIATION ASSOCIATION | | | |
|---|------------|--------------|---------------------------|
| 49 RICHMONDVILLE AVE., WESTPORT, CT 06880 • PHONE: (203) 226-8184 | | | |
| Please check one: <input type="checkbox"/> Change of Address; <input type="checkbox"/> New Membership Application | | | |
| I WISH TO JOIN THE ARMY AVIATION ASSOCIATION OF AMERICA (AAAA), AS A U.S. CITIZEN, MY PAST OR CURRENT DUTIES AFFILIATE ME WITH U.S. ARMY AVIATION AND I WISH TO FURTHER THE AIMS AND PURPOSES OF THE AAAA. I UNDERSTAND THAT MY MEMBERSHIP INCLUDES A SUBSCRIPTION TO THE AAAA-ENGAGED MAGAZINE, "ARMY AVIATION", AND THAT MY MEMBERSHIP WILL START ON THE SUBSEQUENT FIRST OF THE MONTH. THE NAME OF THE CURRENT MEMBER WHO RECRUITED ME IS PRINTED IN THE LOWER RIGHT CORNER. | | | |
| RANK/SGT NO. | FIRST NAME | MI | LAST NAME |
| MAILING ADDRESS | | | |
| CITY STATE ZIP | | | |
| ACTIVE DUTY OR CIVILIAN JOB TITLE | | | |
| UNIT OR FIRM NAME | | | |
| COMMERCIAL () | AREA CODE | OFFICE PHONE | AREA CODE RESIDENCE PHONE |

| AAAA ANNUAL DUES | |
|--|--|
| NEW AND RENEWAL DUES FOR ENLISTED; GS-6 & BELOW; WAIVE BOARD 12 DAC'S & BELOW: | |
| () 1 YR, \$10; | () 2 YRS, \$19; |
| () 3 YRS, \$28 | NEW AND RENEWAL DUES FOR ALL OTHER THAN ABOVE: |
| () 1 YR, \$15; | () 2 YRS, \$25; |
| () 3 YRS, \$43 | ADD \$5 PER YEAR FOR ADD'L POSTAGE IF YOU HAVE A FOREIGN, NON-AP ADDRESS. ADD \$15 IF YOUR CHECK IS DRAWN ON A FOREIGN BANK. |
| [] CHECK ENCLOSED MAKE PAYABLE TO "AAAA." | |
| OR CHARGE TO: [] MASTERCARD; [] VISA | |
| CARD NO. | AMT \$ EXP. DATE |
| SIGNATURE | |

| CHECK (✓) YOUR PROF'L QUALIFICATION | |
|-------------------------------------|------------------------|
| () USA ACTIVE DUTY | () MANUFACTURING* |
| () DA CIVILIAN | () CONSULTANT* |
| () ARMY NAT'L GUARD* | () PROFESSIONAL* |
| () ARMY RESERVE* | () OTHER U.S. SERVICE |
| () ARMY RETIRED* | () OTHER |

*BE CERTAIN TO LIST YOUR CURRENT JOB TITLE AT THE LEFT.

PRINT NAME OF RECRUITER

NEW MEMBERS



AIR ASSAULT CHAPTER FORT CAMPBELL, KY

CPT James W. Crews

ALOHA CHAPTER HONOLULU, HI

CPT Mark N. Mazarella
CPT Bryant N. Poston

ARIZONA CHAPTER MESA, AZ

Mr. Neva B. Johnson
Mr. Joseph L. Thomas

ARMY AVN CENTER CHAPTER FORT RUCKER, AL

WOC Nathan E. Allen
2LT Pedro G. Almeida
MAJ John J. Anton
2LT Mark Bakum
2LT Gary A. Bissell
CPT Robert J. Black
WOC Jerry N. Blackwell
CPT Wendell W. Blair
WOC Richard T. Block
2LT Mark J. Buckley
2LT Virginia M. Burns
MAJ Thomas L. Burton
2LT Joseph A. Capobianco
WOC Michael Carter
WOC William C. Casterlin
WOC Richard K. Chensault
WOC James P. Cook
WOC Richard E. Dashner
WOC Timothy J. Davis
2LT Douglas A. Disinger
CW4 Wendell O. Downs
2LT Mari J. Eaton
WOC George W. Eckart, III
CW3 Albert S. Eggerton
WOC Kevin C. Elmer
WOC Bryan R. Fangman
WOC William Oliver Fountain
2LT Dennis A.K. Fox
CPT Rafael J. Garcia, Jr.
WOC Christopher L. Gardner
WOC Michael G. Gray
WOC David E. Guido
CW3 Joe W. Guthrie
CPT Donald M. Hartley
2LT Carl B. Higgs
WOC Steven E. Hiles
WOC Richard W. Huber
WOC Alan R. Izeck
WOC Paul W. Jenschike
WOC Jeffrey S. Jeter
WOC Ben B. Johnson
2LT Frances V. Johnson
WOC Derryn G. Jones
CO1 David M. Kearney
WOC David R. Kean
LTC Colon Jackson Keel, Jr.
2LT James B. Knappp
WOC Jon M. Lane

2LT Robert W. Lincoln, Jr.
2LT James D. Lord
WOC Edward E. Loscar
2LT David B. Martin
2LT Reginald J. Mason
2LT Sharon I. Mehlhoff
CW2 Michael W. Melton
WOC Stephen D. Middaugh
WOC Mark E. Miller
2LT David C. Morris
WOC Mark K. Morris
2LT Josephine A. Nicolosi
2LT Steven L. Nicolucci
WOC Joseph R. Coborn
SGT Daniel J. Parks
WOC William David Parsons
CPT Allen L. Peterson
CPT Chris A. Phillips
MAJ/P John T. Planchon
2LT Michael D. Pyott
WOC John R. Quatroche, Jr.
2LT Stephen A. Redmond
WOC Craig N. Rubenstein
2LT Richard E. Rufford
WOC Kelly D. Rutledge
WOC Daniel J. Saunders
2LT Joel J. Slagle
2LT Michael F. Sobieski
2LT Robert D. Taylor
2LT Mark A. Thibodeau
WOC Lance A. Walker
WOC Sean M. Walker
WOC Charles N. Wallace, III
SPC Grant M. Watkins
2LT Michael L. Watts
WOC Trenton B. Wilms
CPT Mark E. Winn

BLACK KNIGHTS CHAPTER WEST POINT, NY

2LT Kurt L. Hoernlein

CEDAR RAPIDS CHAPTER CEDAR RAPIDS, IOWA

MAJ Mercer B. Richardson, Ret.

CHEESAPEAKE BAY CHAPTER FORT MEADE, MD

Mr. Donald E. Roberts

COASTAL EMPIRE CHAPTER FT STEWART/HUNTER AAF, GA

1LT Scott M. Fitzgerald
CW2 Mark C. Freshard
CPT Robert W. Gierke
WD1 Jeff C. Guler
1LT Timothy W. Hodge
CPT John G. Stapleton
CPT George A. Stockton
CW2 David A. Swann

COLONIAL VIRGINIA CHAPTER FORT EUSTIS, VA

Dr. Wolf Elber

CW3 William J. Evans

CONNECTICUT CHAPTER STRATFORD, CT

Mr. Mario J. Alvino

CORPUS CHRISTI CHAPTER CORPUS CHRISTI, TX

Mr. Eliseo Andrade, Jr.
Ms. M. Jane Hammons
Mr. Daniel O. Ramos

DELAWARE VALLEY CHAPTER PHILADELPHIA, PA

Mr. Rennie M. Cross
Mr. Jack A. Maynard
WOC Vincent J. Stella

EDWIN A LINK MEMORIAL CHAP BINGHAMTON NY AREA

Mr. Gene G. Abbey
Mr. William L. Adams
Mr. Joseph Badder
Mr. David R. Beck
Mr. Thomas G. Condon
Mr. W. Jerry Duncan
Ms. Patricia A. Foti
Mr. Joseph J. Gaska
Mr. Kenneth E. Harrington
Mr. Ronald N. Hendricks
Mr. John W. Howell
Mr. F. Thomas Jones
Mr. Robert J. Kane
Mr. John M. Kicinski
Mr. John S. Lenyo
Mr. Terry L. McClintic
MAJ Ross A. Miles
COL John P. Ratcliffe, Ret.
Mr. Fred A. Sarnecky, Jr.
Mr. David S. Skutotti
Mr. Charles E. Stuck
Ms. Susan E. Tong
Mr. Joseph G. Wascalis
Mr. Alfred S. Williams, III
Mr. Patrick A. Yearick

FORT BRAGG CHAPTER FORT BRAGG, NC

WO1 Dale J. Jensen
MAJ Julius G. Scott, Jr.

GREATER-ATLANTA CHAPTER ATLANTA, GA

2LT Angela L. Minichiello

HANAU CHAPTER GERMANY

SPC Lori L. Brattin
SPC Donald R. Brennan, Jr.
PFC John M. Carney
CPT Thomas W. Crouch
SSG Paul E. Dixon, III
PV2 Thomas Neil Hall
MAJ Thomas M. Hill
SPC Sandra Kibler
CPT Robert K. Kroening
LTC Charles D. McFetridge
CW3 Robert B. Miller
LTC Daniel A. Poston
CW4 Ray E. Stanton

INDIANAPOLIS CHAPTER INDIANAPOLIS, IN

CPT Robert L. Clugh
PSG Kenneth E. Hicks

JACK H. DIBRELL (ALAMO) FORT SAM HOUSTON, TX

LTC David N. Clark
COL Robert M. Prater, Ret.

LINDBERGH CHAPTER ST. LOUIS, MO

Mr. Roger B. Alons
Mr. Melvin R. Barrett
Ms. Connie L. Carter-Clayton
Mr. Rex L. Cunningham
Ms. Diane M. Dean
MAJ Robert A. Driggers, Jr.
Mr. Bayard E. Foster
LTC Richard H. Frye, Ret.

Mr. James J. Hauser
LTC Richard L. Hazlewood, Ret.
Mr. Michael L. Hooley
Mr. Nathan C. Kieler
MAJ Victor P. Malmgren, Jr.
Mrs. Deborah A. Olson
Mr. Peter L. Rouse
Mr. Frank M. Smith
CW4 Ben Trent, Jr., Ret.
Mr. Robert Utecht
Mr. Robert J. Williams

LONE STAR CHAPTER AUSTIN, TEXAS

Mr. Gerald Neely

MAINE CHAPTER MAINE, GERMANY

CPT Paul V. Gwiazdzinski
MAJ Alfred F. Livaudis, Jr.

MONMOUTH CHAPTER FORT MONMOUTH, NJ

Mr. James P. Sullivan
Mr. Richard L. Wesenjak

MONTEREY BAY CHAPTER FORT ORD, CA

CPT Joseph D. Righetto

MORNING CALM CHAPTER SEOUL, KOREA

MAJ Robert L. Boylston
CW3 Steven A. Overhaug
CW4 Donald R. York

MOUNT RAINIER CHAPTER FORT LEWIS, WA

1LT Brett A. Hartnett
1LT Richard A. Juergens

NORTH TEXAS CHAPTER DALLAS/FORT WORTH

Mr. Robert N. Boothe
Ms. Bobette A. Brasfield

Mr. Terry L. Cottier
Mr. George E. Darsey
Mr. Ernest W. Deadywyler
Mr. Gary L. Dobbs
Mr. Rossie N. Dunn
Mr. Bill Frazee
Mr. Clyde G. Goodnight
Mr. Robert E. Gregory
Mr. Tibbins E. Gunsallias
Mr. Patrick G. Hall
Mr. William L. Harland
Mr. Bill J. Harper
Ms. Linda T. Henderson
Mr. Kenneth E. Hudson
Mr. Richard H. Jackson
Mr. Robert E. Joiner
Mr. Rian Karm
Mr. David W. Kearney
Mr. Dennis C. Lacey
Mr. Nicholas Lambiasse, Jr.
Mr. John P. Latchford
Mr. Anthony L. Leatham
Mr. Paul Lehner
Mr. D. Gary Lerude
Mr. Verliato Lima

Mr. Bruce D. Lowman
Mr. Robin C. Matthews
Mr. Paul E. Moganhan
Mr. John R. Mading
Mr. William H. Reyer, Jr.
Mr. Don R. Rice
Mr. John W. Scoggen
Mr. Harry B. Sheahan
Mr. Carleton K. Sherman
Mr. Bobby R. Smith
Mr. Virgil R. Tindall
Mr. Wilbur R. Toole
Mr. Charles D. Wicker
Mr. John M. Wright

OLD IRONSIDES CHAPTER ANSBACH, GERMANY

CW2 Sean A. Cone
1LT Zane E. De Amaral
1LT Salvatore Frenda

**PHANTOM CORPS CHAPTER
FORT HOOD, TX**

CPT Duane C. Carlton
CW2 Carl L. Farrow
LTC Emil K. Kluever

**PIKES PEAK CHAPTER
FORT CARSON, CO**

CW2 Brett J. Armstrong

**RHINE VALLEY CHAPTER
GERMANY**

MAJ Brent H. Fullerton
1LT D. Mark Heitzig

**SCHWAEBISCH HALL CHAPTER
GERMANY**

MAJ James A. Fuller

**SOUTHERN CALIFORNIA CHAP
LOS ANGELES, CA**

Mr. James Barker
CPT Gerald J. Hopkins
CW2 Peter R. Johnson
WO1 Robert C. Perantie, Jr.
WO1 William J. Petrak
2LT Richard C. Rouvriere
Mr. Gordon L. Rusk

**STUTTGART CHAPTER
STUTTGART, GERMANY**

2LT Kathleen S. Burr

CPT R. and R. Caniglia
SGT Melvin P. Casselberry
SPC David A. Dunson
SPC James A. Gheen
CPT Larry Gissantanna
CW2 Terry L. Hatley
MAJ Mark W. Hays
CW3 Michael A. Kennedy
SGT Kenneth D. McCord
SPC Paul M. Miller
CPT David L. Patterson
CW3 James C. Powell
MAJ Michael L. Reynolds
CPT Michael L. Roberts
CPT Clifton A. Sands

**TAUNUS CHAPTER
GERMANY**

CW3 Michael M. Benson
CW2 Robert F. Borja
CW3 Richard C. Boss
CW4 Keith S. Broome
SPC Matthew M. Burnlyn
CPT Walter W. Champion
WO1 David P. Clark
CW2 Edward M. Cook II
1LT Edward C. Finnegan
WO1 Patsy J. Giarrizzo
CW2 Richard L. Harmon
CW2 Thomas D. Jackson
WO1 Ricard E. Korycinski
1LT Todd D. Kosteletzky
CPT Jon S. Ladd

CW4 John G. Miller
CW2 Stephen J. Miller
1LT Percy G. Parker
MAJ Gary L. Schricker
CW3 Pedro F. Socorro
LTC Brian L. Thom
1SG Randle Varner
CPT Stephen M. Wolis, III
CW4 Robert J. Whitley

**THUNDERHORSE CHAPTER
FULDA, GERMANY**

1LT Brian D. Bennett
CW3 Kent A. Bollaert
SPC Brandon C. Garland
SPC Matthew A. Harrill
PFC Marcos Kocolis
SPC Walter P. Lasauskas
SSG Robert E. Loomis
PFC Robert L. Mitchell
MSG David E. Monks
WO1 Gregory A. O'Neal
PFC Robert A. Pruitt
PFC Robert S. Seybolt
PV Cedrick Shahteen
SPC Paul Sluka
SPC Daniel W. Spargur
CW2 Jeffrey R. Spires
CW2 Robert L. Wargonsky
SPC Paul T. Zutz

**WASHINGTON DC CHAPTER
WASHINGTON, DC**

LTC Michael A. Dauth, Ret.

MAJ Pieter M. Drog
COL John A. Duff, Ret.
MAJ Matthew C. Matia

**WINGS OF THE DEVIL CHAP
FORT POLK, LA**

CPT Richard E. Ford
CW4 Frank A. Tigano

**WINGS OF THE MARNE CHAP
GERMANY**

CPT Marcus D. Blair

**MEMBERS WITHOUT
CHAPTER AFFILIATIONS**

WOC David J. Bellware
WO1 Theodore J. Coto-Manes
WOC Edward C. Deguisio, III
Mr. Armand L. Fortin
Mr. Scott G. Hutchens
2LT Robert A. Hyland
Mr. James H. Johnson
COL James S. Kessler
WOC Joseph T. Mattingly
Mr. Cameron L. Orr
Mr. Paul J. Patin
Mr. Terry D. Porter
LTC/P Jeffrey A. Roy
Mr. John Robert Stiggins
Dr. Edward A. Stark
WOC James E. Ward
2LT Daniel Winchester, Jr.

**Aviation Soldiers
of the Month**

SPC Paul Zutz, Thunderhorse Chapter (February).

SPC Paul Sluka, Thunderhorse Chapter (April).

PFC John M. Camey, Hanau Chapter (August).

SPC Sandra Kibler, Hanau Chapter (September).

SPC Daniel W. Spargur, Thunderhorse Chapter (Sept).

SPC Grant M. Watkins, Aviation Center Chapter (October).

New AAAA Officers

The following members were elected to the Executive Boards of their respective Chapters:

MAJ John Schoonover, (Secretary), **LTC Daniel Poston**, (VP Activities), **Hanau Chapter**.

1LT Richard A. Juergens, (VP Publicity), **Mount Rainier Chap.**

MAJ Lawrence E. Wessman, (Actg. Pres.), **MAJ Robert L. Oates**, (Treasurer), **Stuttgart Chapter**.

CW4 John Martin, (Trea), **Wings of the Marne Chapter**.



Chapter News



COL Theodore A. Duck, Aloha Chapter President, poses with Door prize winners. L to R: 1LT Juliette T. Ritzman, CW2 James W. Hill, COL Duck, CPT Clarence S. Kelly, SGT William L. Isaac.

Aloha Chapter, Honolulu, Hawaii. A general membership meeting was held October 21, 1988. Chapter President, COL Theodore Duck thanked those who participated in the AAAA car wash - almost \$500 was earned. Membership, Scholarship Programs and National Awards were discussed. A drawing was held to award three members gift certificates from the Hale Koa Hotel for two free Sunday brunches. A gift cer-

tificate was also presented to the member who signed up the most new members at this meeting, CPT Clarence S. Kelly. The runners up were MAJ Michael K. Minich, MAJ(P) John P. (Skip) Lam, and CW2 William D. Shumate. A total of 26 new members joined AAAA.

Edwin A. Link Memorial Chapter, Binghamton, NY. The meeting was called to order by Chapter President, Fred Belyea. Bill Hush, VP Membership, reported on membership status. A motion was made to charge non-members an additional fee at AAAA professional sessions to encourage them to join. It was decided that a Christmas Dance subsidized by the Chapter should be pursued. Motion was made to allocate \$200 from the treasury to buy AAAA paraphernalia to sell at professional sessions and for coffee cups to reward those members who recruit the most new members.



Chapter News



North Texas, Dallas/Fort Worth, TX. The September meeting of the AAAA North Texas Chapter was a hands-on learning experience as members and guests participated in the First Annual Defense Systems Management Seminar, September 22, 1988. Over 160 people from the Dallas/Fort

Worth Metroplex attended the all-day seminar hosted by Texas Instruments' LeRoy Worm, North Texas Chapter President.

Bill Mitchell, President of the TI's Defense Systems & Electronics Group, welcomed participants to the seminar. Seminar leaders, who discussed all facets of DoD procurement, were Dr. Julius Hein (pictured above left with President Worm), Director, Central Region, Defense Systems Management College; DSMC processors Dr. Fred Waelchli, Dr. Jay Billings and Mr. Bill Forbes; and Mr. Drew Casani, LTV.



AAAA Calendar



A listing of recent past AAAA Chapter Events and upcoming National dates

December, 1988

- ■ Dec. 1. Fort Bragg Chapter. Professional Luncheon Meeting Fort Bragg Main Officer's Club. Guest Speaker, COL(P) Marvin E. Mitchiner, Jr.
- ■ Dec. 2. Wings of the Marne Chapter. Business Social Mtg. Giebelstadt Officer's and Senior NCO Club.
- ■ Dec. 8. 1988 Aviation Trainer of the Year Award and Top ROTC Cadet Award Presentation, Fort Rucker, AL.
- ■ Dec. 9. AAAA National Executive Board Meeting, Fort Rucker, AL.

February, 1989

- ■ Feb. 3-4. AAAA National Awards Committee Meetings to select CY88 National Award Win-

ners and CY89 National Scholarship Award Winners.

- ■ Feb. 14-16. 15th Annual Joseph P. Cribbins Product Support Symposium sponsored by the Lindbergh Chapter. Stouffer Concourse Hotel, St. Louis, MO.

- ■ Feb. 15. Outstanding Avn Logistics Support Unit of the Year Award Presentation and Industry Award Presentations, Stouffer Concourse Hotel, St. Louis, MO.

March, 1989

- ■ Mar. 11-18. AAAA Ski Week in Garmisch hosted by the 12th Aviation Brigade.

April, 1989

- ■ Apr. 5-9. AAAA National Convention, Georgia World Congress Center, Atlanta.



MG Ellis D. Parker (right), Commanding General, U.S. Army Aviation Center, Fort Rucker AL, is presented with a commemorative "Blue Box" plaque by Fred Belyea, President, Edwin A. Link Chapter. Parker was the featured guest at the Chapter's October dinner meeting in Binghamton, NY.

New Industry Members

SciTek, Science & Technology, Inc., of St. Louis, MO.

New Sustaining Members

(Designated Representatives indicated in parenthesis)

Perlman Motors of Russellville, KY. (Mr. Frank Perlman)

Aces

The following members have been declared Aces in recognition of their being responsible for the signing up of five new members each.

- CPT Thomas D. Beato
- CPT James F. Edwards
- COL Leslie T. Everett, Jr.
- CPT Scott W. Hollingsworth
- CPT Clarence S. Kelly
- MAJ/P John R. Lam, Jr.
- Mr. Thomas J. Molanda
- CW2 Alice A. Reno
- CW2 William D. Shumate



AAAA ASE Symposium sets attendance record in St. Louis



The Sixth Annual AAAA Aircraft Survivability Equipment (ASE) Symposium was held November 9-10, 1988 in St. Louis, MO, hosted by Emerson Electric, Electronics and Space Division, at its St. Louis headquarters.

A record 160 attendees were greeted by the master of ceremonies, MG Story C. Stevens, Ret., AAAA President, as he introduced the Emerson host, Richard D. Koetting, Assistant Vice President, Electronics & Armament Engineering.

COL James R. Holder, ASE Project Manager, opened the professional sessions and introduced BG Rodney D. Wolfe, Assistant Commandant, U.S. Army Aviation Center, Ft. Rucker, AL, who delivered the Keynote Address "The Importance of ASE and ASE Training".

The 15 technical presentations covered the full spectrum of ASE issues:

"OSD Perspective of ASE" by Anthony R. Grieco, Assistant Director, Electronic Combat Systems, Office of the Secretary of Defense for Command, Control, Communications, and Intelligence, Washington, DC;

"LHX Integrated Survivability" by James M. Richey, Chief, Mission Equipment Branch, LHX PMO;

"ASE's Role in Air Assault Mission Accomplishment" by LTC Charles B. Cook, Commander, 4th Aviation Battalion, 101st Aviation Regiment, Ft. Campbell, KY;

"ECM Effectiveness" by Myron Greenbaum, Director, Advanced EW Systems, ITT Avionics Division, co-authored by Joseph Graziano;

"U.S. Air Force REDCAP Simulator — U.S. Army Applications" by David R. Beck, Deputy for Test Operations, Calspan Corp., REDCAP Facility;

"Emerson Tactical Radar Threat Generator" by Robert E. Seamands, Senior Engineering Scientist, Emerson Electric Company and CW4 Samuel D. Stone, Aviation Training Development Officer, DOTD, U.S. Army Aviation Center.

"EW Simulation: A Realistic Training Alternative" by Charles R. Chapman, Manager, Technology Applications, Anaren Microwave, Inc.;

"ALERTS — An In Flight ASE Training Device" by Robert L. Reagan, Program Development, Teledyne Brown Engineering;

"Full Scale Development of a Variable Geometry Infrared Suppressor for the V-22 OSPREY" by Gabor Kossuth, Program Engineer, Heat Transfer Group, Aircsearch, Allied Signal Aerospace. James Eastwood was the author of this presentation;

"Electronic Warfare Suite Performance and Maintenance Effectiveness Model" by John R. Scoggins, Advanced Technology Engineering, Sanders Associates, Lockheed Corporation. Co-author was Thomas B. Gould.

"Advanced Airborne Countermeasures Dispensers and Expendables for Aircraft and Crew Survivability" by Bill J. Anderlohr, Jr., Business Development Manager, Advanced Dispenser Systems, Tracor Aerospace, Inc.

"Common Opto-Electronic Laser Detection System" by David L. Cunningham, Program Manager, Tracor Aerospace, Inc.

"Embedded Electronic Warfare (EW) Training" by Dr. Ted Gettinger, Senior Scientist, McDonnell Douglas Helicopter Company.

"Advanced Soviet SAM Threats to Low Flying Army Helicopters" by Ronald J. Langiotti, Manager, Modeling and Simulation, Northrop Defense Systems Division.

"Mission Essential Functional Compatibility and Maneuver Strategy" by Joseph A. Genovese, Project Engineer, Grumman Aircraft.

The highpoint of the Sixth ASE Symposium was the presentation of the AAAA "Aircraft Survivability Award" to Richard Paoletta.

The AAAA ASE Award, bestowed to the AAAA by Loral Electronic Systems, is presented annually during the ASE Symposium to the individual who has made an outstanding contribution to Army Aviation in the area of aircraft survivability equipment during the previous calendar year. The trophy is on permanent display at the U.S. Army Aviation Museum in Ft. Rucker, AL.

Mr. Paoletta, Project Leader, Countermeasures, Electronic Warfare Protection Branch, Electronic Warfare Laboratory, received a standing ovation when recognized for his successful year-long efforts to implement an extremely sensitive and tactically critical program, which resulted in the timely and essential delivery of systems that were immediately deployed to meet real world threats.

Following the presentation of the award, BG David L. Funk, Program Executive Officer, Aviation, introduced Donald N. Fredericksen, Deputy Under Secretary of Defense for Tactical Warfare Programs as the Banquet Guest Speaker.

Following the last of the second day's presentations, the 1988 ASE Symposium drew to a close as COL Holder delivered his final remarks and President Stevens presented Certificates of Appreciation to COL Holder, PM-ASE and CPT (P) Joseph A. Durso, APM-ASE.



Banquet Speaker Donald N. Fredericksen (l), Deputy Under Secretary of Defense for Tactical Warfare Programs, and BG David L. Funk (r), PEO, Aviation, at the ASE Awards Banquet.



President Stevens (l) and COL Holder (r) pose with CY87 ASE Award winner Richard Paoella.



(photos by Bob Wadlow, Emerson)

Left to right: BG Rodney D. Wolfe, Assistant Commandant, USAAVNC; COL James R. Holder, PM-ASE and MG Story C. Stevens, Ret., AAAA President, during the 1988 AAAA ASE Symposium with Emerson Electric host, Richard D. Koetting.



AAAAA

TRAINING THE ARMY AVIATION FORCE

**AAAA Annual Convention
Atlanta, Georgia**

April 5-9, 1989

(see the next issue for details)

Collins AN/ASC-15B(V)1 provides four radios in a single mobile command and control communications system. ■ It gives battlefield commanders enhanced flexibility in fast-changing tactical environments. The system can be quickly and easily removed from the host aircraft to provide a stand-alone ground command post. ■ The ASC-15B(V)1 consists of three ARC-182 VHF/UHF radios and one ARC-174 HF radio to provide multiband coverage with a full range of secure voice and data communications, satellite communications, automatic channel scanning and NOE IFM. ■ Our system is NATO and Tri-Service interoperable, and has planned growth (P³) including Have Quick and SINCGARS. The ASC-15B(V)1 is a non-developmental item (NDI) with all principal communication equipment currently in the U.S. DoD inventory. ■ Contact: Collins Defense Communications, Rockwell International, Cedar Rapids, Iowa 52498. U.S.A. (319) 395-1600. Telex 464-435. ■ **COLLINS ACCD: The Electronic Combat Specialists.**

OUR ASC-15B(V)1 KEEPS BATTLE COMMANDERS IN CONTROL.



**Rockwell
International**

...where science gets down to business

Aerospace / Electronics / Automotive
General Industries / A-B Industrial Automation